

Water Quality Monitor

FilterSmart™ Backwash Monitor

OVERVIEW

Until now, operators have had to rely on two key surrogate measurements: flow rate and time. With the FilterSmart™ backwash monitor, operators can directly measure the parameters of interest: media expansion and turbidity. Equipped with these tools, operators can develop conditional backwash controls based on the actual conditions in the filter, and target significant savings.

The FilterSmart operating system was developed to address the unique measurement requirements of granular media filters during backwash. Primary measurement indications are media level, media expansion in engineering units and as a percentage of expandable media and backwash turbidity in the range of 0.0...50.0 NTU. Together, these measurements provide the essential information necessary for effective backwash control.

FilterSmart is the only instrument bundle designed specifically and uniquely for filter backwashing. Combining two measurements into one sensor provides direct monitoring of the two parameters that are needed for cost-effective and efficient filter cleaning. See [Figure 1 on page 2](#).

FilterSmart can be implemented as individual, stand-alone instruments or with numerous sensors networked together and operated by a single controller.

DESCRIPTION

FilterSmart is an application-specific version of the EchoSmart™ ultrasonic interface level analyzer. Implementations typically employ a sensor that includes a fully integrated, scattered light turbidity meter.

FilterSmart Sensor: The FilterSmart Sensor is a microprocessor controlled piezoelectric transducer designed specifically for operation under water (submerged in the process liquid).

The Sensor generates an ultrasonic sound wave that propagates through the filter water above the filter media and is reflected back. The sound wave travels at known velocities, providing the ability to convert elapsed time into media level and expansion measurements. With a known dimension to the bottom of the expandable media, the measurement can be expressed in terms of the depth of the filter media, and the amount of expansion during backwash can be calculated both in engineering units and as a percent of the total media depth.

Sensors that include a scattered light turbidity measurement provide a highly useful additional measurement of backwash turbidity.



FilterSmart Controller: The FilterSmart Controller allows for programming and local monitoring of 1...16 FilterSmart Sensors. A single Controller can operate up to 16 FilterSmart Sensors in a wired or wireless field network. In either arrangement, the network is fully integrated and requires no software integration by the customer. The Controller handles all programming and monitoring functions for all sensors in the network.

FilterSmart Power Supply: The FilterSmart Power Supply unit provides power to a FilterSmart Sensor and acts as a communication hub to facilitate analog, digital and wireless RF communications from a FilterSmart Sensor.

The FilterSmart Controller and FilterSmart Power Supply unit are designed for indoor and outdoor installation.

APPLICATIONS

- Drinking Water and Wastewater Treatment Filter
- Tertiary Filters in Wastewater Treatment
- Granular Media Pressure Filter

The FilterSmart backwash monitor is suitable for most municipal and industrial granular media gravity filters. It may also be used in granular media pressure filters subject to certain mechanical, pressure, physical and installation limitations. Contact Badger Meter Technical Support at techsupport@badgermeter.com for details.

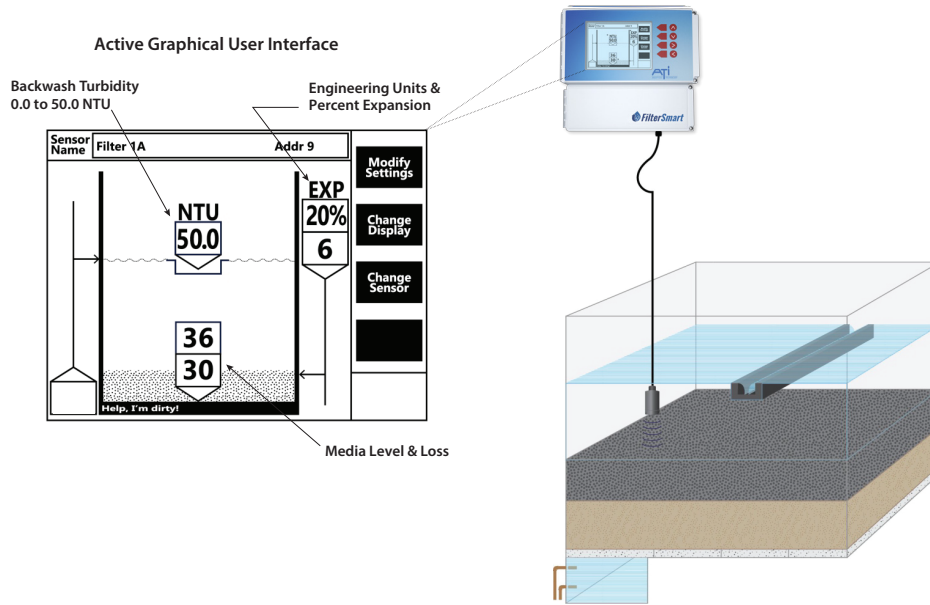

Figure 1: FilterSmart graphical user interface

SPECIFICATIONS

Smart Sensors

Measurement Principle	Underwater acoustic
Power Requirement	15V DC; 3W
Range	1.0...20.0 ft (0.305...6.1 m)
Sensor Meas. Resolution	0.1 unit of measure
Accuracy	0.2 in. at 10.0 ft (5 mm at 3.05 m)
Operating Temperature	34...125° F (1...52° C)
Configuration Backup	Settings stored in FLASH memory
Sensor Construction	IP68, ABS and epoxy Stainless steel and rubber (wiper only)
Turbidity	Measurement principle: 90° scattered light, pulsed LED Range: 0...50 NTU Repeatability: 1% @ 50 NTU*
Weight	2.75 lb (1.25 kg)
Certifications	CE

* Accuracy has been tested under controlled conditions using an AMCO solution and field results of $\pm 2\%$ across the measurement range can be expected with an installation on a properly grounded circuit. Since the Sensor is installed in an active filter, turbidity readings can be affected by bubbles, poor electrical grounding, localized flow rate at the Sensor and heavier suspended solids that may be present dynamically.

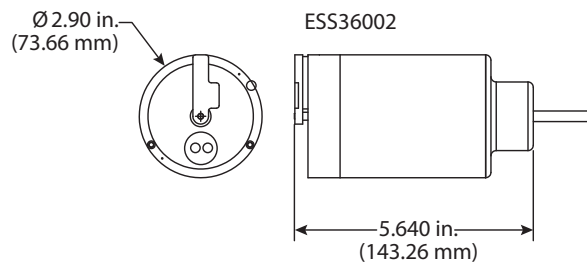

Figure 2: Sensor dimensions

Controller

Input Power	100...240V AC, 50/60 Hz – 1.5A, 70W Optional 24V DC: 19...42V DC
Supply Cable	10...18 AWG, –40...140° F
Fuse	1.25A 250V 5 × 20 mm T-lag UL approved fuse
Analog Loops	(2) 4...20 mA Outputs 15...24V DC (provided by FSC for local sensor)
Ambient Temperature	–40...140° F (–40...60° C)
Display	Graphical backlit monochrome screen Resolution: 320 × 240 pixels Viewing Area: 2.6 × 3.45 in. (92 × 122 mm)
Communications	RS-485 Modbus RTU (2) 4...20 mA Output: (1) Media level, expansion or percent expansion (1) Turbidity
Reported Meas. Resolution	1.0 (in. and cm), 0.1 (ft), 0.01 (m)
RF Module for Europe (optional)	868 MHz frequency band Self-healing mesh network Approvals: CE RED
RF Module for North America (optional)	900 MHz frequency band Self-healing mesh network Approvals: FCC Part 15C, Industry Canada
Relays (optional)	(4) Relays: 10A @ 250V AC; 10A @ 30V DC
Modbus to Analog Output Converter (optional)	18...30V DC, DIN rail mount, up to 16 isolated analog outputs
Mounting Configurations	Surface and pipe mounting
Enclosure	NEMA 4X, IP65; Polycarbonate
Weight	Approx. 3.0 lb (1.36 kg) depending on configuration
Certifications	CE

IMPORTANT

Delays in data retrieval from multiple sensors can exist because of the unpredictable nature of wireless communication due to interference, distance, obstructions and so on. The wireless field network is therefore not recommended unless the local analog outputs are being used.

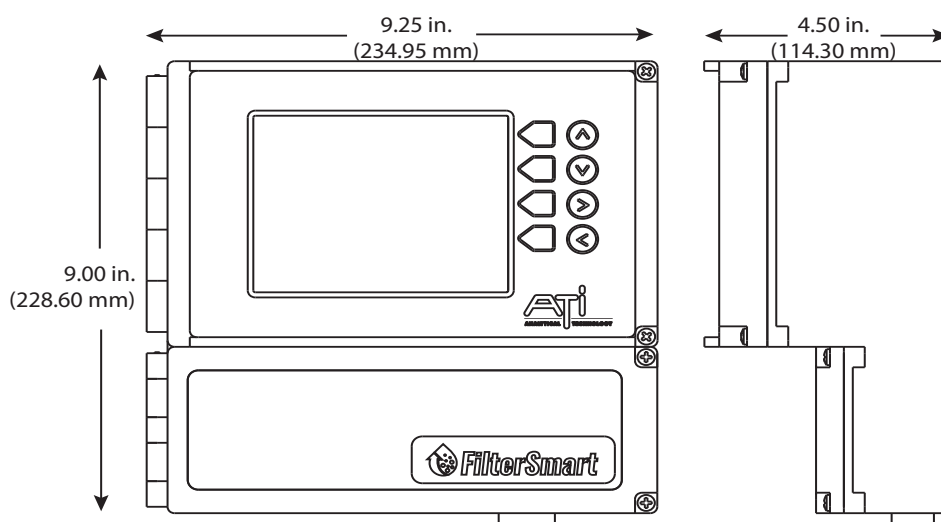

Figure 3: Controller dimensions

Power Supply Unit (Required only in multi-sensor network applications)

Power Requirements	100...240V AC, 50/60 Hz, 0.5A, 20W Optional 24V DC, 18...36V DC
Supply Cable	10...18 AWG, -40...140° F
Fuse	0.250A, 250V 5 × 20 mm T-lag UL approved fuse
Analog Loops	15...24V DC (provided by FSP for local sensor) (2) 4...20 mA Outputs
Ambient Temperature	-40...140° F (-40...60° C)
Communications	RS-485 Serial Modbus RTU (2) 4...20 mA Output: (1) Media level, expansion or percent expansion (1) Turbidity
RF Module for Europe (optional)	868 MHz frequency band Self-healing mesh network Approvals: CE RED
RF Module for North America (optional)	900 MHz frequency band Self-healing mesh network Approvals: FCC Part 15C, Industry Canada
Integral RF Module	Optional
Mounting Configurations	Surface and pipe mounting
Enclosure	NEMA 4X, IP65; Polycarbonate
Weight	Approx. 1.5 lb (0.68 kg)
Certifications	CE

IMPORTANT
Delays in data retrieval from multiple sensors can exist because of the unpredictable nature of wireless communication due to interference, distance, obstructions and so on. The wireless field network is therefore not recommended unless the local analog outputs are being used

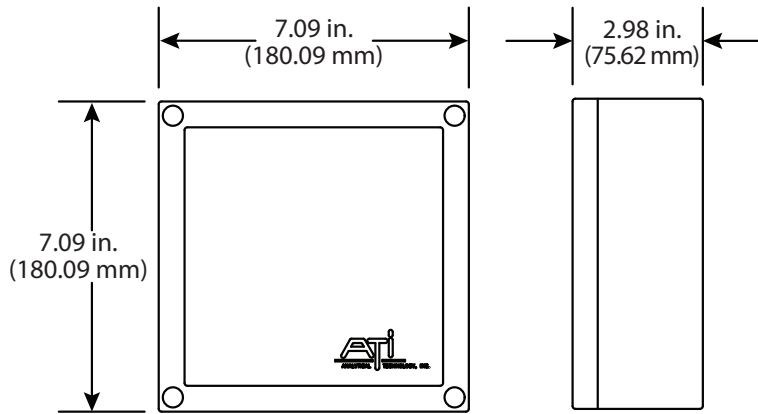

Figure 4: Power supply unit dimensions

