

## Head-mounted Two-wire Signal Conditioners 27-UNIT

### 2-WIRE UNIVERSAL TEMPERATURE TRANSMITTER (HART communication)

#### Functions & Features

- Universal input: DC mV, T/C, RTD and resistance
- High accuracy
- HART communication
- Intrinsically safe approval
- Suitable for Functional Safety applications up to SIL2
- Programming via hand-held communicator or via PC
- A wide variety of T/C and RTD types
- User's temperature table can be used
- Self diagnostics
- Ultra-low temp. drift option (20 ppm/°C typ.)
- CE marking (conforms to ATEX and EMC)

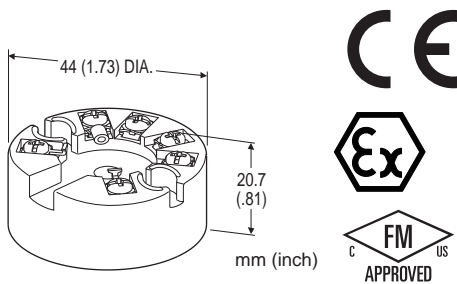

## MODEL: 27HU-[1][2]

### ORDERING INFORMATION

- Code number: 27HU-[1][2]
- Specify a code from below for each [1] and [2].  
(e.g. 27HU-2/L)
- Use Ordering Information Sheet (No. ESU-7651). Factory standard setting will be used if not otherwise specified.  
Specify the country in which the product is to be used with the Safety Approval code 2.

### [1] SAFETY APPROVAL

- 0: None
- 1: FM intrinsically safe
- 2: CENELEC intrinsic safety (ATEX)

### [2] OPTIONS

#### Temperature Drift

- Blank:** Standard (temp. coefficient 0.015%/°C)
- /L:** Ultra-low temperature drift  
(temp. coefficient 0.002%/°C typ., 0.005%/°C max.)

### RELATED PRODUCTS

- USB interface Bell202 modem (model: COP-HU)  
Usable in 'non-hazardous' area only.
- Hand-held communicator
- PC configurator software (model: 27HUCFG)  
Downloadable at M-System's web site.

### GENERAL SPECIFICATIONS

- Construction:** Sensor head-mounting
  - Connection:** M3 screw terminals (torque 0.5 N·m)
  - Screw terminal:** Nickel-plated brass
  - Housing material:** Flame-resistant resin (black)
  - Isolation:** Input to output
  - User-configurable items:**
    - Input sensor type and numbers
    - Number of wires (RTD & resistance)
    - Input range (inverted range selectable)
    - Burnout
    - Output limits (Upper / Lower)
    - Damping time (factory set to 0)
    - Cold junction compensation (T/C; internal or external sensor selectable)
    - Linearization
    - Sensor calibration
    - Output calibration
    - HART communication mode
- Refer to the HART setup manual or the PC configurator users manual for the detail.

### HART COMMUNICATION

- Protocol:** HART communication protocol
- HART address range:** 0 - 15 (factory set to 0)
- Transmission speed:** 1200 bps
- Digital current:** Approx. 1 mA<sub>p-p</sub> when communicating
- Character format:** 1 Start Bit, 8 Data Bits, 1 Odd Parity Bit, 1 Stop Bit
- Distance:** 1.5 km (0.9 miles)
- HART communication mode:** Master-Slave Mode and Burst Mode (factory set to Master-Slave)
- HART network mode:** Point-to-Point Mode and Multi-drop Mode; automatically set to Multi-drop Mode when the address is set to other than 0.

### INPUT SPECIFICATIONS

- The input is factory set for use with K thermocouple, single input, 0 to 100°C, internal CJC sensor.
- See Table 1 for the available input type, the minimum span and the maximum range.
- DC mV (dual input available)
- Input resistance:** ≥ 1 MΩ
- Thermocouple (dual input available)

**Input resistance:**  $\geq 1 \text{ M}\Omega$   
**Burnout sensing:** 33  $\mu\text{A}$   
**External CJC sensor type:** Pt 100  
**■ RTD (2-wire, 3-wire or 4-wire)**  
**Input resistance:**  $\geq 1 \text{ M}\Omega$   
**Excitation:** 0.2 mA  
**Allowable leadwire resistance:** Max. 10  $\Omega$  per wire  
**■ Resistance (2-wire, 3-wire or 4-wire)**  
**Input resistance:**  $\geq 1 \text{ M}\Omega$   
**Excitation:** 0.2 mA  
**Allowable leadwire resistance:** Max. 10  $\Omega$  per wire

Consult M-System.

## STANDARDS & APPROVALS

### EU conformity:

ATEX Directive

Ex ia EN 60079-11

EMC Directive

EN 61326-1

RoHS Directive

EN 50581

### Safety approval:

FM: Intrinsically safe

Class I, Division 1, Groups A, B, C and D

Class I, Zone 0, AEx ia IIC (US)

Class I, Zone 0, Ex ia IIC (Canada)

T4, T5 and T6

(Class 3610, ANSI/ISA 60079-11,

CAN/CSA-C22.2 No. 157,

CAN/CSA-C22.2 No. 60079-11)

CENELEC: Intrinsic safety (ATEX)

 II 1G, Ex ia IIC; T4, T5 and T6  
(EN 60079-11)

## OUTPUT SPECIFICATIONS

**Output range:** 4 - 20 mA DC  
**Operational range:** 3.75 - 23 mA  
**Load resistance vs. supply voltage:**  
 Load Resistance ( $\Omega$ ) = (Supply Voltage (V) - 8 (V))  
 $\div 0.023$  (A) (including leadwire resistance)  
**Burnout:** 3.75 - 3.8 mA or 21.5 - 23 mA  
 (factory set to 23 mA)  
**Upper output limit proportional to the input:**  
 20 - 21.5 mA (factory set to 21.5 mA)  
**Lower output limit proportional to the input:**  
 3.8 - 4 mA (factory set to 3.8 mA)  
**Update time:** 440 msec. (660 msec. with dual input)  
**Output characteristics for dual input:**  
 Average or Differential selectable

## SAFETY PARAMETERS

### Operating temperature

For CENELEC (ATEX) / FM:

T4: -40 to +80°C

T5: -40 to +60°C

T6: -40 to +45°C

### Ex-data:

- Output circuit
  - Ui (Vmax): 30 V DC
  - Ii (Imax): 96 mA DC
  - Pi (Pmax): 720 mW
  - Ci: 1 nF
  - Li: 0 mH
- Sensor circuit
  - Uo (Voc): 30 V DC
  - Io (Isc): 24 mA DC
  - Po: 180 mW
  - Co (Ca): 50 nF
  - Lo (La): 40 mH

## INSTALLATION

**Supply voltage**  
 · 8 - 35 V DC (non-approved)  
 · 8 - 28 V DC (approved)  
**Operating temperature:** -40 to +85°C (-40 to +185°F)  
 (See Safety Parameters for use in a hazardous location.)  
**Operating humidity:** 0 to 95 %RH (non-condensing)  
**Mounting:** Head-mounting (DIN type B head)  
**Weight:** 50 g (1.76 oz)

## PERFORMANCE

**Accuracy:** See Table 1.  
**Cold junction compensation accuracy:**  $\pm 0.5^\circ\text{C}$  ( $\pm 0.9^\circ\text{F}$ ) with internal CJC sensor  
**Response time:**  $\leq 2$  sec. (0 - 90 %) with damping time set to 0 and when not communicating via HART.  
**Supply voltage effect:**  $\pm 0.005$  % of span/V  
**Insulation resistance:**  $\geq 100 \text{ M}\Omega$  with 500 V DC  
**Dielectric strength:** 1500 V AC @1 minute (input to output)  
**Safety integrity level according to IEC 61508:** Suitable for use in a safety instrumented system up to SIL2 (together with sensor) if appropriate safety instructions are observed.

## INPUT TYPE, RANGE & ACCURACY

INPUT TYPE				MINIMUM SAPN	MAXIMUM SPAN	ACCURACY *1	TEMPERATURE DRIFT	
							STANDARD DRIFT *2	ULTRA-LOW DRIFT *3
DC mV				4 mV	-100 to +800 mV	±10 µV	±1.5 µV/°C	±0.5 µV/°C
Resistance				25 Ω	0 to 4 kΩ	±0.1 Ω	±15 mΩ /°C	±5 mΩ /°C
Thermocouple	°C			°F			TEMPERATURE DRIFT	
	MINIMUM SAPN	MAXIMUM RENG	ACCURACY *1	MINIMUM SAPN	MAXIMUM RENG	ACCURACY *1	STANDARD DRIFT *2	ULTRA-LOW DRIFT *3
K (CA)	50	-180 to +1372	±0.5	90	-292 to +2501	±0.9	±0.075°C/°C	±0.025°C/°C
E (CRC)	50	-100 to +1000	±0.5	90	-148 to +1832	±0.9	±0.075°C/°C	±0.025°C/°C
J (IC)	50	-100 to +1200	±0.5	90	-148 to +2192	±0.9	±0.075°C/°C	±0.025°C/°C
T (CC)	50	-200 to +400	±0.5	90	-328 to +752	±0.9	±0.075°C/°C	±0.025°C/°C
B (RH)	100	400 to 1820	±1	180	752 to 3308	±1.8	±0.3°C/°C	±0.1°C/°C
R	100	-50 to +1760*4	±1	180	-58 to +3200*4	±1.8	±0.3°C/°C	±0.1°C/°C
S	100	-50 to +1760*4	±1	180	-58 to +3200*4	±1.8	±0.3°C/°C	±0.1°C/°C
C (WRe 5-26)	100	0 to 2300	±1	180	32 to 4172	±1.8	±0.3°C/°C	±0.1°C/°C
D (WRe 3-25)	100	0 to 2300	±1	180	32 to 4172	±1.8	±0.3°C/°C	±0.1°C/°C
N	50	-180 to +1300	±0.5	90	-292 to +2372	±0.9	±0.075°C/°C	±0.025°C/°C
U	50	-200 to +600	±0.5	90	-328 to +1112	±0.9	±0.075°C/°C	±0.025°C/°C
L	50	-100 to +900	±0.5	90	-148 to +1652	±0.9	±0.075°C/°C	±0.025°C/°C
RTD	°C			°F			TEMPERATURE DRIFT	
	MINIMUM SAPN	MAXIMUM RENG	ACCURACY *1	MINIMUM SAPN	MAXIMUM RENG	ACCURACY *1	STANDARD DRIFT *2	ULTRA-LOW DRIFT *3
Pt 100 (JIS '97, IEC)	10	-200 to +850	±0.1	18	-328 to +1562	±0.18	±0.015°C/°C	±0.005°C/°C
Pt 200	10	-200 to +850	±0.1	18	-328 to +1562	±0.18	±0.015°C/°C	±0.005°C/°C
Pt 500	10	-200 to +850	±0.1	18	-328 to +1562	±0.18	±0.015°C/°C	±0.005°C/°C
Pt 1000	10	-200 to +850	±0.1	18	-328 to +1562	±0.18	±0.015°C/°C	±0.005°C/°C
JPt 100 (JIS '89)	10	-200 to +510	±0.1	18	-328 to +950	±0.18	±0.015°C/°C	±0.005°C/°C
Ni 100 (DIN 43760 '87)	10	-60 to +250	±0.2	18	-76 to +482	±0.36	±0.015°C/°C	±0.005°C/°C

- \*1. DC mV: Or ±0.05 % of absolute range (greater of 0 % and 100 % range values), whichever is greater.  
 Or ±0.2 % of absolute negative range for two inputs including negative ranges, whichever is greater.
- Resistance: Or ±0.05 % of absolute range (greater of 0 % and 100 % range values), whichever is greater.
- Thermocouple: Or ±0.05 % of span, whichever is greater. Add cold junction compensation error.
- RTD: Or ±0.05 % of max. range (greater of 0 % and 100 % range values converted into °C), whichever is greater.  
 (For 2- or 3-wire RTD, the value is valid by the sensor calibration after wiring is complete.)
- \*2. Or ±0.015 % of absolute range/°C (greater of 0 % and 100 % range values), whichever is greater.
- \*3. Or ±0.005 % of absolute range/°C (greater of 0 % and 100 % range values), whichever is greater.
- \*4. Conformance range: 50 to 1760°C or 122 to 3200°F

## DIMENSIONS unit: mm (inch)

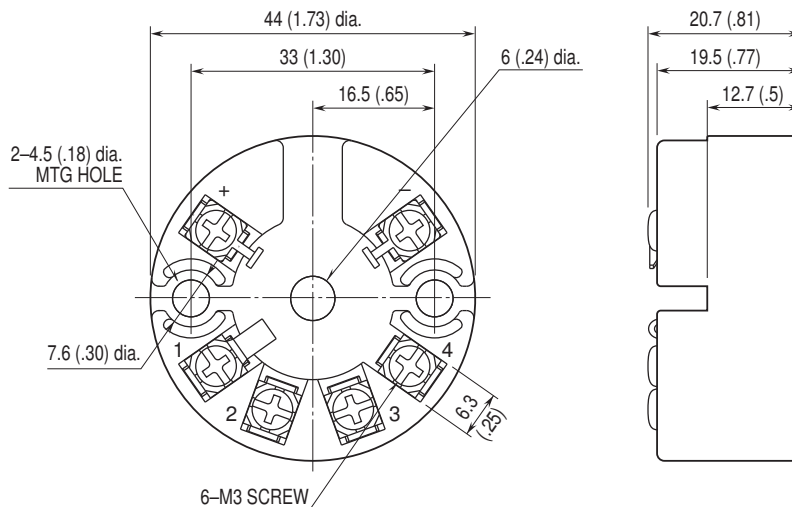

## MOUNTING REQUIREMENTS unit: mm (inch)

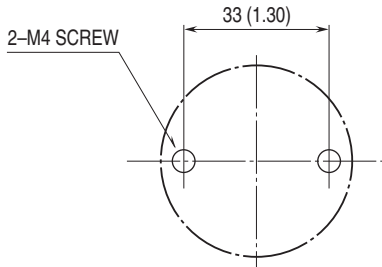

The screws are to be provided by the customer.

## SCHEMATIC CIRCUITRY & CONNECTION DIAGRAM

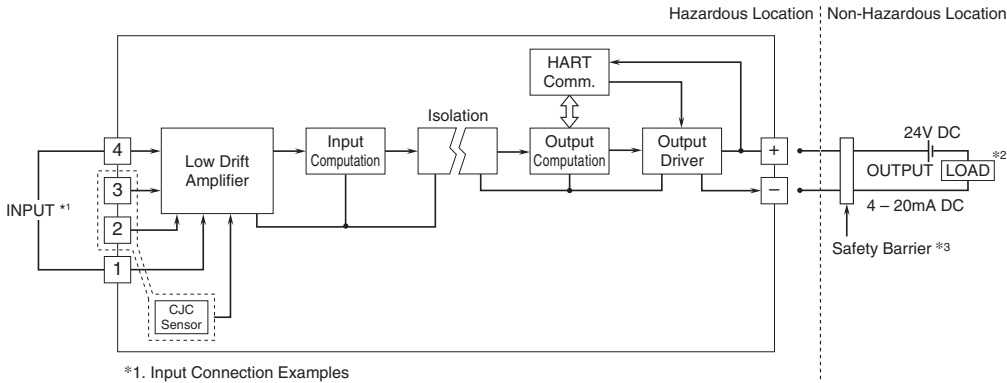

■ DC MILLIVOLT

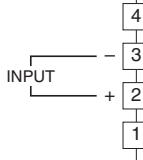

• Two Inputs

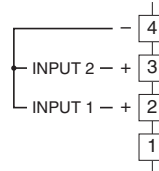

■ THERMOCOUPLE

• Internal CJC

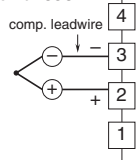

• External CJC

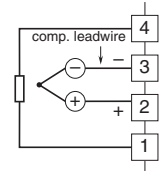

■ RTD & RESISTANCE

• Two-wire

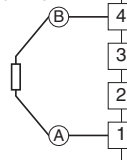

• Three-wire

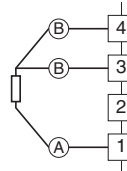

• Two Inputs, Internal CJC

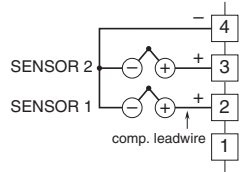

• Four-wire

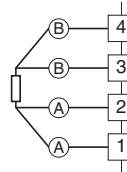

• Two Inputs, External CJC

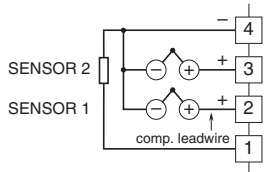

\*2. Limited to 250 – 1100 Ω for HART communication.

\*3. A safety barrier must be installed for the intrinsic safety.

The safety barrier must meet the Ex-data of this unit and must be approved for the hazardous location.



Specifications are subject to change without notice.