

# Installation, Operation & Maintenance Manual

**ST80 / ST80L**  
Thermal Mass Flow Meter

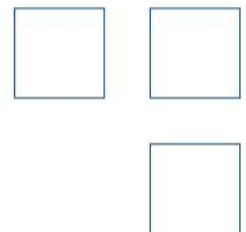

**Notice of Proprietary Rights**

This document contains confidential technical data, including trade secrets and proprietary information which is the property of Fluid Components International LLC (FCI). Disclosure of this data to you is expressly conditioned upon your assent that its use is limited to use within your company only (and does not include manufacture or processing uses). Any other use is strictly prohibited without the prior written consent of FCI.

© Copyright 2021 by Fluid Components International LLC. All rights reserved. FCI is a registered trademark of Fluid Components International LLC. Information subject to change without notice.

## Table of Contents

Table of Contents.....	iii
List of Figures .....	v
List of Tables.....	vii
Typographical Conventions .....	viii
1 GENERAL .....	1
Product Description.....	1
Theory of Operation .....	1
Safety Instructions.....	1
Order Verification .....	1
Technical Specifications.....	3
2 INSTALLATION.....	7
Instrument Identification and Outline Dimensions .....	7
ST80 Insertion Sensor Installation .....	7
ST80L In-Line Process Connection .....	14
Installation of Probe with Moisture/Rain Shield.....	14
Flow Transmitter Electronics Installation.....	16
Instrument Wiring .....	20
Post Installation Check.....	29
3 OPERATION .....	31
Basic Commissioning and Start-Up .....	31
Configuring the ST80/ST80L.....	31
Verify Engineering Units.....	35
System Faults, Alarms and Logging Indication .....	35
ST80/ST80L Configuration Software Application (User Password: 2772) .....	36
Real Time Clock.....	37
Totalizer Setup .....	38
Configuring for AST™ or Constant Power Measurement Methods .....	39
Flow Filtering.....	40
NAMUR Setup.....	41
Internal Delta-R Resistor (idR) Check.....	43
Using Digital Outputs .....	46
HART Operation.....	47
HART Command List Reference.....	52
Modbus Operation.....	70
4 MAINTENANCE .....	77
Introduction .....	77
General Maintenance.....	77
Power Fuse Replacement.....	78
Lithium Battery Replacement.....	79

5	TROUBLESHOOTING .....	81
	Non-Maintenance Observations.....	81
	General Function Check .....	82
	Troubleshooting the Flow Element.....	83
	Verification of the Electronics.....	85
	Constant Power Configuration Troubleshooting .....	87
	Defective Parts .....	89
	Customer Service.....	89
	Reference: Error/Status Register Information .....	90
	APPENDIX A DRAWINGS.....	93
	APPENDIX B ADDITIONAL INFORMATION .....	125
	Parameters Report from the ST80/ST80L Configuration Application (Sample).....	126
	HMI Menu Outline .....	131
	ST80/ST80L Configuration Software Menu Outline (v3.2.0.x).....	132
	Instructions: Installing Sun Shield on ST80/ST80L Integral Enclosure .....	133
	Instructions: Installing Sun Shield on ST80/ST80L Remote Enclosure .....	134
	APPENDIX C GLOSSARY.....	135
	Abbreviations .....	135
	Definitions.....	135
	APPENDIX D APPROVAL INFORMATION.....	137
	Safety Instructions.....	138
	APPENDIX E CUSTOMER SERVICE .....	143
	Customer Service/Technical Support.....	143

## List of Figures

Figure 1 – Example Compression Fitting Process Connection.....	7
Figure 2 – Compression Fitting Installation, Dimensions.....	8
Figure 3 – Example Flange Mount Installation.....	9
Figure 4 – Example NPT Pipe Thread Mount Installation.....	9
Figure 5 – Retractable Packing Gland Installation.....	10
Figure 6 – Flow Element Installation Using FCI Retractor Tool 026854-01.....	12
Figure 7 – Packing Gland Locking Collar.....	12
Figure 8 – ST80L Process Connection.....	14
Figure 9 – Installation of Sensor Probe with Moisture/Rain Shield.....	15
Figure 10 – Integral Electronics Installation (Compression Fitting Shown).....	16
Figure 11 – Remote Installation, Mounting Bracket on Wall.....	17
Figure 12 – Remote Installation, Mounting Bracket on 1" – 1½" Pipe.....	18
Figure 13 – Remote Installation, Mounting Bracket on 2" Pipe.....	18
Figure 14 – Remote Installation, Optional Stainless Steel Bracket on 2" Pipe.....	19
Figure 15 – Recommended Wiring Routing, Base Electronics Enclosure.....	20
Figure 16 – ST80/ST80L I/O Connector Locations.....	21
Figure 17 – ST80/ST80L Electronics Enclosure Label.....	22
Figure 18 – Bus Configuration 2 mm Jumper Headers and DIP Switch.....	22
Figure 19 – Input Power Wiring.....	23
Figure 20 – ST80/ST80L Ferrite Core Installation.....	23
Figure 21 – Flow Element Connections, TB1.....	24
Figure 22 – HART and Ch. 1 & Ch. 2 4-20 mA Connections, J25.....	25
Figure 23 – Single Connection and Multidrop HART Setups.....	26
Figure 24 – Modbus/PROFIBUS/Fieldbus Connections, J8.....	27
Figure 25 – Modbus Wiring.....	27
Figure 26 – Fieldbus/PROFIBUS Wiring.....	28
Figure 27 – Hot Key on the Optional HMI Display.....	31
Figure 28 – HMI Display IR Sensor Functions.....	32
Figure 29 – Basic Setup Options, HMI.....	33
Figure 30 – Instrument Setup Options.....	33
Figure 31 – Display Setup Options.....	34
Figure 32 – Configuration Software Tabs for Basic Setup Functions.....	35
Figure 33 – Example Log, Alarm, and Logging Icons on the Optional Display.....	36
Figure 34 – The Configurator Welcome Screen.....	36
Figure 35 – Example Process Data Screen.....	37
Figure 36 – Example Date and Time Set Screen.....	37
Figure 37 – Example Totalizer Display Showing Total Flow Value.....	38
Figure 38 – Totalizer Setup Screen.....	38
Figure 39 – Example AST Power Mode Tab (Configuration).....	39

Figure 40 – Flow Filtering Setup Screen.....	40
Figure 41 – Chart: Flow Output Over Time with Various Flow Damping Values .....	41
Figure 42 – NAMUR Fault.....	41
Figure 43 – NAMUR Output Level Selection (4-20 mA User Tab).....	42
Figure 44 – Example idR Check Results Display .....	43
Figure 45 – Example Internal Delta R Scheduled Screen (After Clicking "Run test now...") .....	44
Figure 46 – Example Internal Delta R Test Logs Screen.....	44
Figure 47 – Internal Delta-R Resistor Check (idR) HMI Display Sequence.....	45
Figure 48 – Digital Bus Deactivation Warning When Enabling HART .....	46
Figure 49 – Field Communicator Easy Upgrade Utility, Import DD.....	48
Figure 50 – ST80/ST80L Configuration Software Output Tab with Modbus Selected .....	70
Figure 51 – ST80/ST80L Configuration Software Modbus Tab, Serial Interface Configuration .....	71
Figure 52 – Fuse Location, Power Supply Board .....	78
Figure 53 – Instrument Disassembly for Lithium Coin Cell Battery (CR2450N) Replacement .....	80
Figure 54 – Example Heater Values Tab (Diagnostics).....	84
Figure 55 – System Status LED, Main Board .....	85
Figure 56 – DMM Hookup to Measure 4-20 mA Output.....	87
Figure 57 – Connecting FES-200 to ST80/ST80L Transmitter .....	88
Figure 58 – ST80/ST80L Decade Box Wiring.....	88

## List of Tables

Table 1 – Compression Fitting Material .....	8
Table 2 – Interconnecting Cable Minimum Conductor Size .....	20
Table 3 – Modbus Select Jumpers .....	28
Table 4 – Modbus Line Configuration Jumpers .....	28
Table 5 – FOUNDATION Fieldbus/PROFIBUS Select Jumpers .....	29
Table 6 – FOUNDATION Fieldbus/PROFIBUS Line Configuration Jumpers .....	29
Table 7 – Flow Parameters, HMI .....	34
Table 8 – Fatal Faults that Trigger NAMUR .....	42
Table 9 – ST80/ST80L HART Process Variables .....	47
Table 10 – ST80/ST80L HART Field Device Registration Information .....	48
Table 11 – HART Universal Commands .....	52
Table 12 – HART Common Practice Commands .....	59
Table 13 – ST80/ST80L HART Device Specific Command Groupings .....	61
Table 14 – HART Device Specific Commands .....	61
Table 15 – Command Status Bytes, Bit Assignments .....	67
Table 16 – Command-Specific Response Codes .....	67
Table 17 – Command 48, Additional Device Status Bytes Bit Assignments .....	68
Table 18 – HART Engineering Units Codes .....	69
Table 19 – ST80/ST80L Modbus Function Codes .....	71
Table 20 – ST80/ST80L Modbus Process Data .....	72
Table 21 – Modbus Service Data -- Service and Setup Functions .....	73
Table 22 – ST80/ST80L Modbus Engineering Unit Codes .....	75
Table 23 – ST80/ST80L Modbus Exception Codes .....	76
Table 24 – ST80/ST80L Modbus Variables and Registers Map .....	76
Table 25 – Power Fuse Summary .....	78
Table 26 – Lithium Coin Cell Battery Summary .....	79
Table 27 – Flow Element Resistance Measurements (In Ohms) Taken From Remote/Integral Electronics .....	83
Table 28 – Flow Element Resistance (In Ohms) at the Local Enclosure .....	83
Table 29 – Nominal Heater Parameter Ranges .....	84
Table 30 – System Status LED D3 States .....	85
Table 31 – Instrument Power Supply Voltages .....	86
Table 32 – Basic CORE Fault Register (CORE CY Command) .....	90
Table 33 – Detailed CORE Fault Register (CORE 2V Command) .....	91
Table 34 – FE Fault Register (FE DF Command) .....	92
Table 35 – ST80/ST80L Drawings in Appendix A .....	93

## Typographical Conventions

Important notes or warnings are shown like the following:

- Note:** A note is additional information that adds to or supplements the topic.
- Caution:** A caution indicates an action that can cause equipment damage, loss of data or software, or minor injury.
- Warning:** A warning indicates an action that can cause equipment damage, or serious injury/death, or both.

Caution symbols that may be marked on the product or its packaging are explained below:



Risk of Danger symbol (observe all warnings and cautions in manual).



Hot Surface Caution symbol (risk of burn from probe heater).



ESD (Electrostatic Discharge) Susceptibility symbol (do not touch without appropriate precautions).



Static-sensitive Devices symbol (use ESD handling procedures).



# 1 GENERAL

## Product Description

The ST80/ST80L is a thermal dispersion, industrial process grade air/gas flow meter. It is suitable for all air and gas flow measurement applications in line sizes from 1" to 100" [25 to 2500 mm] and larger. The instrument provides direct mass flow measuring and measures flow rate, totalized flow and temperature.

The measurements are made available to the user by way of 4-20 mA analog output channels with HART or Modbus (standard) or other pre-selected digital bus options. The optional graphics display provides real-time process variable values along with flow range and process description information.

There are no moving parts to clean or maintain. A wide selection of process connections are offered to fit with any process piping. Versions are available for temperature service from -40 °F [-40 °C] to 850 °F [454 °C].

The ST80/ST80L electronics/transmitter can be integrally mounted with the flow sensor or remote mounted up to 1000' [300m] from the sensor element. The ST80/ST80L features the FCI exclusive AST™ (patent pending) adaptive sensing technology measuring technique that provides for improved response time and accurate flow measurement. All ST80/ST80L instruments are precision calibrated in FCI's world-class, NIST traceable calibration facility on one of our flow stands matched to your gas application and actual installation conditions.

## Theory of Operation

The instrument is functionally based on the thermal dispersion operating principal. With AST™, power to the active RTD sensor's heater is varied to maintain a constant Delta T with the reference (unheated) RTD sensor. The flow rate and the heater power needed to maintain Delta T is proportional. Once the heater current reaches a set maximum, the heater current is maintained as the instrument reads the varying sensor resistance (Delta R). This resistance is proportional to flow rate. The transition between reading the heater power (constant Delta T) and reading the sensor resistance (constant power) is seamless and automatic and is the key to the AST™ feature. The differential signal, whether it's from the sensor heater power (constant Delta T) or the sensor resistance (constant power) is scaled to drive a 4-20 mA flow output. A second temperature output, from the unheated reference sensor, drives a second 4-20 mA output.

## Safety Instructions

**Warning:** Explosion Hazard. Do not disconnect equipment when flammable or combustible atmosphere is present.

- Field wiring shall be in accordance with NEC (ANSI-NFPA 70) or CEC (CSA C22.1) locations as applicable.
- The instrument must be installed, commissioned and maintained by qualified personnel trained in process automation and control instrumentation. The installation personnel must ensure the instrument has been wired correctly according to the applicable wiring diagram.
- All location specific installation and wiring requirements must be met and maintained. FCI recommends an input power circuit breaker be installed between the power source and the flow meter. This facilitates easy power disconnection during commissioning and maintenance procedures. **Use a switch or circuit breaker if the instrument is in a hazardous area.**
- The flow meter contains electrostatic discharge (ESD) sensitive devices. Use standard ESD precautions when handling the circuit board assemblies.
- Hazardous Areas: The instrument is designed for use in hazardous areas. The approved area classification is identified on the nameplate along with the temperature and pressure limitations. The USB port does not support the hazardous area requirements and should only be used when the area is declassified. Remove any non-certified parts such as plastic protection caps from cable entry ports and replace by suitable wiring and cabling system certified by notified bodies for use in hazardous areas.
- When mounting the flow element into the process pipe, it is important that a lubricant/sealant is applied to the mating threads. Use a lubricant/sealant that is compatible with the process media. Tighten all connections firmly. To avoid leaks do not overtighten or cross-thread connections.

## Order Verification

- Verify the received hardware matches the purchased hardware and application requirements. Verify the model/part number on the instrument I.D. tag (e.g., ST80L – 43E8000...) matches the purchased model/part number.
- Review the Calibration requirements as specified on the Engineering Data Sheet in the documentation package. Verify the flow, temperature and pressure limits meet the application requirements.

**Hardware - Model Descriptions**

ST80 – Single point insertion element with flow and temperature process output

ST80L – In Line element with flow and temperature process output

**Documentation and Accessories**

06EN003490 ST80/ST80L Installation, Operation, & Maintenance Manual

06EN003491 ST80/ST80L Configuration Software Manual

Calibration Certification Documentation

PC Configuration Software and USB Cable

**Supplemental Manuals, optional**

06EN003492 ST80/ST80L FOUNDATION™ Fieldbus Manual

06EN003493 ST80/ST80L PROFIBUS PA Manual

06EN003494 ST80/ST80L PROFIBUS DP Manual

**Supplemental Software, optional**

HART DD Files

FOUNDATION Fieldbus

PROFIBUS DD File

PDM/DTMs

## Technical Specifications

### Instrument

#### Measuring Capability

Flow rate, total flow and temperature

#### Basic Style

ST80: Insertion

ST80L: In-line (spool piece)

#### Flow Measurement Range

*Insertion Style:* 0.25 SFPS to 1000 SFPS [0,07 NMPS to 305 NMPS]

ST80L In-line: 0.0062 SCFM to 1850 SCFM

[0.01 NMCH to 3,140 NMCH]

– Air at standard conditions; 70 °F and 14.7 psia [21 °C and 1,01325 bar (a)]

#### Temperature Measurement Range

Up to 850 °F [454 °C] commensurate with element; see *Operating Temperature* in Flow Element specification

#### Environmental Conditions

Maximum Relative Humidity: 93%

Maximum Elevation: 6561' [2000m]

#### Media

All gases that are compatible with the flow element material

#### Accuracy

*Flow:*

Gas Specific Calibration:  $\pm 1.0\%$  reading,  $\pm 0.5\%$  full scale

*Temperature:*

$\pm 2$  °F [ $\pm 1,1$  °C] (display only, flow rate must be greater than 5 SFPS [1,5 m/sec])

#### Response Time (Flow)

1 second to 63% of final value (one step change) typical with –FP or –FPC type flow element operating in AST mode

#### Temperature Coefficient

With optional temperature compensation; valid from 10% to 100% of full scale calibration

Flow: Maximum  $\pm 0.015\%$  of reading / °F up to 850 °F [ $\pm 0.03\%$  of reading / °C up to 454 °C]

#### Repeatability

Flow:  $\pm 0.5\%$  reading

Temperature:  $\pm 1$  °F [ $\pm 0.6$  °C] (flow rate must be greater than 5 SFPS [1,5 NMPS])

#### Turndown Ratio

Normally factory set and field adjustable from 2:1 to 100:1 within calibrated flow range

#### Temperature Compensation

Standard:  $\pm 30$  °F [ $\pm 16$  °C]

Optional:  $\pm 100$  °F [ $\pm 55$  °C]

#### Agency Approvals

**FM, FMC:** XP Class I, Division 1, Groups B, C, D  
DIP Class II/III, Division 1, Groups E, F, G  
NI Class I, Division 2, Groups A, B, C, D  
NI Class II, Division 2, Groups E, F, G  
DIP Class III, Division 1, 2  
T6 Ta = -40°C to 40°C,  
T5 Ta = -40°C to 55°C,  
T4 Ta = -40°C to 60°C  
Type 4X, IP66/IP67  
NEC 500

**ATEX:** II 2 G Ex db IIC T6...T1 Gb Ta = -40°C to + 60°C  
II 2 D Ex tb IIIC T85°C...T450°C Db Ta = -40°C to + 60°C  
IP66/67

**IECEx:** Ex db IIC T6...T1 Gb Ta = -40°C to + 60°C  
Ex tb IIC T85°C...T450°C Db Ta = -40°C to + 60°C; IP66/67

**Other:** CE Marking  
Probe complies with Canadian Electrical code requirements of ANSI/ISA 12.27.01-2011 as a single seal device.

#### SIL/IEC 61508: SIL 1 Compliant, SFF 71.1% to 79.1%

#### Calibration: Performed on NIST and and ISO/IEC 17025 traceable flow stands and equipment

#### Other: Follows best practices and guidelines as set forth in ISO 14511; complies with ISO 14164

#### Storage Temperature

-76 to 150 °F [-60 to 65 °C]

### Flow Element

#### Material of Construction

All-welded 316L stainless steel; Hastelloy-C optional

#### Operating Pressure

*ST80 Insertion Style*

Metal ferrule: 1000 psig [69 bar (g)]

Teflon ferrule: 150 psig [10 bar (g)] (200 °F [93 °C] max.)

Packing gland (low pressure): 50 psig [3.5 bar (g)]

Packing gland (medium pressure): 500 psig [34 bar (g)]

Fixed 1" NPT: 1000 psig [69 bar (g)]

Fixed flange: per flange rating

*ST80L In-line Style*

	Tubing		Sch 40 Pipe		Sch 80 Pipe	
	psig	bar(g)	psig	bar(g)	psig	bar(g)
<b>F Style Sensor</b>						
1"	2400	165	2500	172	3000	207
1½"			1750	121	2500*	172*
2"			1500	103	2250*	155*
<b>S Style Sensor</b>						
1"	2400	165	2500	172	2500	172
1½"			1750	121	2500*	172*
2"			1500	103	2250*	155*

\* 1½" and 2" Sch 80 available by special order only; contact FCI.  
¾" pipe also available by special order.

■ **Operating Temperature (Process)**

*ST80 Insertion Style (FPC, FP, and S sensor head types)*

Process Connection	Transmitter	Temp. Service <sup>1</sup>
Compression Fitting	Integral/Remote	Lo: 350 °F [177 °C] <sup>2</sup>
		Med: 500 °F [260 °C]
Low Pressure Packing Gland	Integral/Remote	Lo: 350 °F [177 °C]
		Med: 500 °F [260 °C]
	Remote	Hi: 850 °F [454 °C]
Med. Pressure Packing Gland	Integral/Remote	Lo: 350 °F [177 °C]
		Med: 500 °F [260 °C]
	Remote	Hi: 850 °F [454 °C]
Fixed NPT	Integral/Remote	Lo: 350 °F [177 °C]
		Med: 500 °F [260 °C]
	Remote	Hi: 850 °F [454 °C]
Fixed Flange (1" or DN25)	Integral/Remote	Lo: 350 °F [177 °C]
		Med: 500 °F [260 °C]
Fixed Flange (≥1½" or ≥DN40)	Integral/Remote	Lo: 350 °F [177 °C]
		Med: 500 °F [260 °C]
	Remote	Hi: 850 °F [454 °C]

Notes: 1. Minimum temperature is -40 °F [-40 °C].  
 2. For Teflon ferrule max. temperature is 200 °F (93 °C).

*ST80L In-line Style (F and S sensor head types)*  
 -40 °F to 257 °F [-40 °C to 125 °C]

■ **Model ST80, Process Connections and Insertion Lengths**

*Compression Fittings: Model ST80 only*

¾" or 1" male NPT, stainless steel with adjustable Teflon ferrule or metal ferrule; or flanged tapped and threaded for ¾" fitting, ANSI or DIN flanges.

Compression fittings not available with 850 °F [454 °C] temperature versions of ST80.

*Retractable Packing Glands*

Low pressure 50 psig [3,5 bar (g)] or medium pressure 500 psig [34 bar (g)] with graphite or Teflon packing material; 1¼" male NPT or ANSI or DIN flange.

Teflon packing required when process media is ozone, chlorine or bromine. Remote mount required when medium pressure packing gland is required.

*Fixed Fittings/All Welded*

1" male NPT, ANSI or DIN flange

*Insertion Length*

Field adjustable lengths:

1" to 6" [25 mm to 152 mm]	1" to 12" [25 mm to 305 mm]
1" to 21" [25 mm to 533 mm]	1" to 36" [25 mm to 914 mm]
1" to 60" [25 mm to 1524 mm]	

Fixed lengths from 2.6" to 60" [66 mm to 1524 mm]

■ **Model ST80L, In-line Flow Body and Process Connections**

Flow element is calibrated and supplied as a spool-piece; options include low flow injection tubes and built-in Vortab flow conditioners for optimum low flow rangeability and performance

Size: 1" diameter tubing; 1", 1½", or 2" Schedule 40 pipe; 1" Schedule 80 pipe

Length: 9 nominal diameters

Process Connections: female NPT, male NPT, ANSI or DIN flanges, or butt weld prepared

Option: Flanges sized for flow tube

■ **Remote Transmitter Configurations**

Transmitter may be mounted remotely from flow element using interconnecting cable (up to 1000 ft [300 m]). Remote configuration required with selection of medium pressure packing gland.

■ **Flow Transmitter/Electronics**

■ **Operating Temperature**

-40 °F to 140 °F [-40 °C to 60 °C]

■ **Input Power**

AC: 100 VAC to 265 VAC, 50 Hz to 60 Hz

DC: 24 VDC (19.2 – 28.8 volts)

■ **Power Consumption**

AC: 10 W, 1 Flow Element

DC: 9.6 W, 1 Flow Element

■ **Battery Backup (for RTC)**

Industrial-spec 3V Lithium coin cell type CR2450N

■ **Outputs**

*Analog*

Standard: Two (2) 4-20 mA outputs\*.

4-20 mA outputs are user assignable to flow rate and temperature; outputs are user programmable to full flow range or subsets of full flow range.

\* Outputs are isolated and have fault indication per NAMUR NE43 guidelines, user selectable for high (>21.0 mA) or low (<3.6 mA)

HART (comes standard with analog outputs), V7 compliant.

*Digital*

Standard: USB (service and configuration port only); Modbus RS-485

Optional: FOUNDATION Fieldbus H1, PROFIBUS PA, or PROFIBUS DP.

*FF Physical Parameters*

Maximum Network Input Voltage - U<sub>i</sub> (in V) = 32

Maximum Network Input Current - I<sub>i</sub> (in mA) = 13

■ **Enclosures**

*Main Transmitter/Electronics:*

NEMA 4X, IP66/67 polyester powder coated aluminum or optional 316L stainless steel.

Four (4) cable ports ½"-14 NPT or M20 x 1.5

Size: 5" W x 5.40" H x 7.75" L (127 mm x 137 mm x 197 mm)

*Local Enclosure (Remote Configuration):*

- Single cable port enclosure (available with packing gland/low and med press; ≥1.5" fixed flange; fixed NPT process connections):

NEMA 4X, IP66/67 polyester powder coated aluminum or optional 316L stainless steel.

One (1) cable port 1"-11.5 NPT

Size: 4.68" W x 4.87" H x 5.4" L (119 mm x 124 mm x 137 mm)

- Dual cable port enclosure (available with compression fitting; 1" fixed flange process connections):

NEMA 4X, IP66/67 polyester powder coated aluminum or optional 316L stainless steel.

Two (2) cable ports 1/2"-14 NPT or M20 x 1.5

Size: 3.27" W x 3.54" H x 3.9" L (83 mm x 90 mm x 99 mm)

■ **Readout/Display (Option 1):**

- Large backlit 2" x 2" [50 mm x 50 mm] LCD for display of digital flow rate, analog bar graph of flow rate, total flow, and temperature; user selectable engineering units, and alarm/fault status indication.
- User programmable 17 alphanumeric character field associated with each calibration group.
- Set-Up & Service mode displays text and service codes.
- Display is electronically rotatable in 90° increments to optimize viewing angle.

**Note:** For units without the display option, the service port (USB) lets a PC configure/manage the instrument via the ST80/ST80L configurator utility.

■ **Readout/Display and Optical Touch Buttons (Option 2)**

Includes the *Readout/Display Option 1* items, plus adds four keypad/buttons for the user interface.

- Four (4) optical touch buttons for user programming of instrument set-up and service interrogation.
- User programming and setup via the front panel.
- Optical touch button activation through front window – no need to open enclosure to access or activate.
- Set and adjust the meter or interrogate diagnostics in-situ, even in HazEx installation.

**Other Options**

■ **Vortab Flow Conditioners**

Available for all line size applications; standard choice with Model ST80L (in-line).

■ **Sun Shield**

Shades main transmitter, electronics, and display from direct sunlight; 316L stainless steel.

FCI P/N 023241-01 *Integral transmitter*

FCI P/N 023237-01 *Remote transmitter*

■ **Ball Valves/Cable Glands**

■ **Certification and Testing Documentation**

CMTR, NACE, PMI, O<sub>2</sub> cleaning, radiography, dye penetrant, hydrostatic or air pressure test, certificate of origin, certificate of conformance, wake frequency strength, and more.

■ **Field Service and Support**

Start-up assistance, site commissioning and installation validation, maintenance agreements, bus communications integration and validation, and more.

This Page Intentionally Left Blank

## 2 INSTALLATION

- Warnings:**
- Consult the manufacturer if dimensional information on the flameproof joints is necessary.
  - The ambient temperature range and applicable temperature class of the ST80/ST80L flow meter is based on the maximum process temperature for a particular application. Refer to page 138 for details.
  - The painted surface of an ST80/ST80L flow meter (aluminum housing only) can store electrostatic charge and become a source of ignition in applications with a low relative humidity < 30% relative humidity where the painted surface is relatively free of surface contamination such as dirt, dust, or oil. Clean painted surfaces using a damp cloth moistened with water only.
  - Do not replace internal battery when an explosive gas atmosphere is present.

### Instrument Identification and Outline Dimensions

APPENDIX A starting on page 93 provides outline dimensions and mounting bracket dimensions for all integral and remote mounted electronic configurations. Verify all dimensions meet the application requirements before beginning the installation process.

### ST80 Insertion Sensor Installation

The proper flow meter location in the process piping configuration is critical to the instrument's ability to measure the process variables accurately. FCI recommends 20 nominal pipe diameters upstream and 10 pipe diameters downstream of the instrument installation point for most applications. These distances can be significantly reduced when the flow meter is combined with FCI's flow conditioning technology (Vortab).

Insertion flow elements can be mounted into the process using several available customer selectable configurations; compression fitting mounted, threaded or flanged packing gland mounted, and threaded or flanged fixed "U" length mounted process connections. The specific sensor process connection is specified by the customer on the order information sheet (OIS).

Mount the flow element to the process piping per the application piping requirements. Orient the instrument so that the flow arrow etched on the element matches the direction of the process flow with the reference flat parallel to flow within  $\pm 3^\circ$  of rotation. Insert a flow element with variable insertion length  $\frac{1}{2}$ " inch past the centerline of the process pipe or tube with the flow direction arrow correctly aligned and leveled. After the flow element has been located correctly and tightened into place, verify that the process seal does not leak by slowly applying pressure until the maximum operation pressure is applied. Check for leaks at the process connection boundary using standard leak detection methods.

Figure 1 below shows a properly mounted compression fitting process connection instrument.

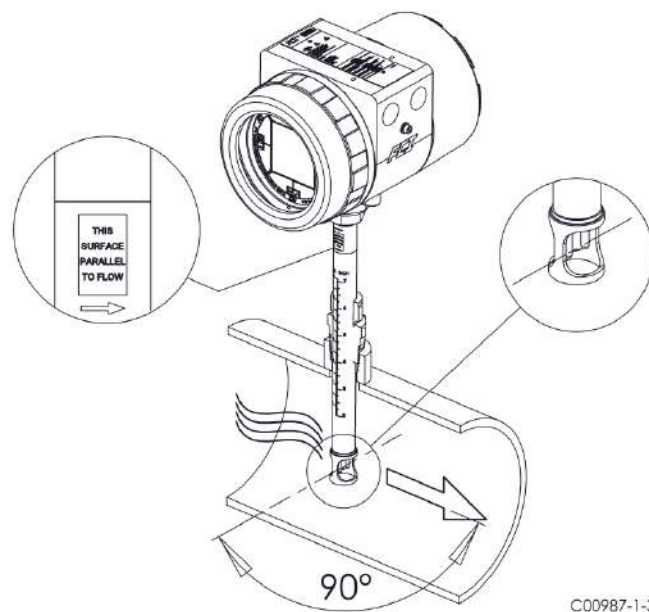

Figure 1 – Example Compression Fitting Process Connection

**Compression Fitting**

FCI single point insertion flow meters are calibrated at the centerline of the process pipe. The flow element is properly mounted when the tip of the flow element is located 0.50 inches (13 mm) past the pipe centerline. See Figure 2 below. The scale etched on the side of the insertion pipe indicates the length to the tip of the flow element. Follow the steps below to install the compression fitting flow element.

1. Calculate the insertion depth using the equation below.

I = Insertion depth  
 I.D. = Pipe inside diameter  
 T = Pipe wall thickness  
 C = Pipe mounting coupling and compression fitting (installed length)

$$I = 0.50" + \frac{I.D.}{2} + T + C$$

I = \_\_\_\_\_

2. Mark the insertion pipe at the calculated insertion depth.

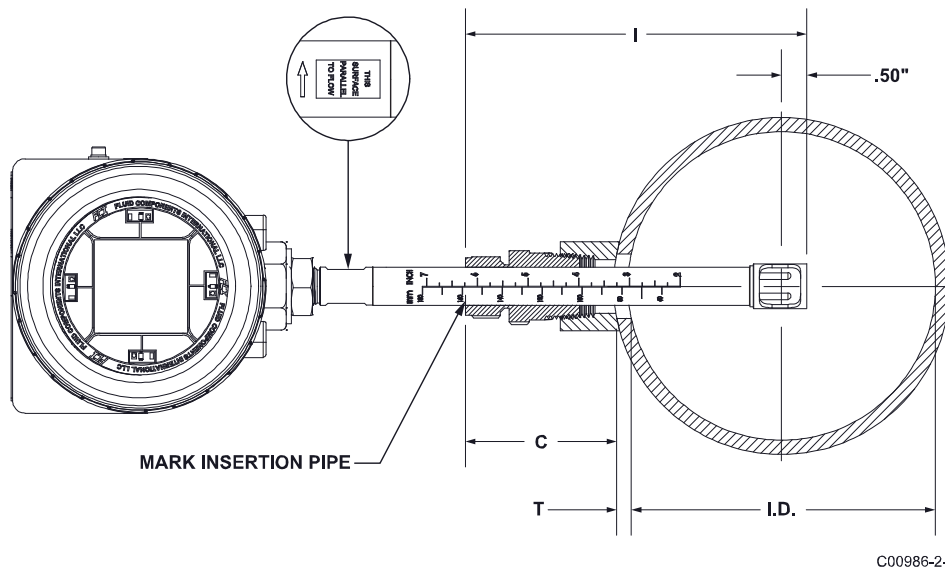

**Figure 2 – Compression Fitting Installation, Dimensions**

3. Apply proper thread sealant to the tapered pipe thread on the compression fitting and secure into pipe mounting coupling.
4. Insert the flow element to the insertion depth mark making sure the orientation flat is aligned parallel to the flow direction. Hand tighten the compression nut. Compression fitting manufacturer recommends 1¼ turns past hand tight.
5. Tighten the compression nut to the torque specified for the corresponding ferrule material. See Table 1 below.

**Table 1 – Compression Fitting Material**

Ferrule Material	Torque
Teflon	6 ft-lbs
316 SST <sup>1</sup>	65 ft-lbs <sup>1</sup>

**Note:** The metal ferrule configuration can only be tightened one time. Once tightened, the insertion length is no longer adjustable.



### Flange Mount

The flange mount flow element is shown in [Figure 3](#) below. Attach the process mating flange with care. Correctly orient the flow element's reference flat to ensure the instrument's calibrated accuracy.

- Verify the process media flow matches the flow direction arrow on the flow element.
- Apply appropriate gasket and or sealant to flange mount as required.
- Mate flow element flange to process flange keeping flat oriented properly.
- Secure flanges with appropriate mounting hardware.

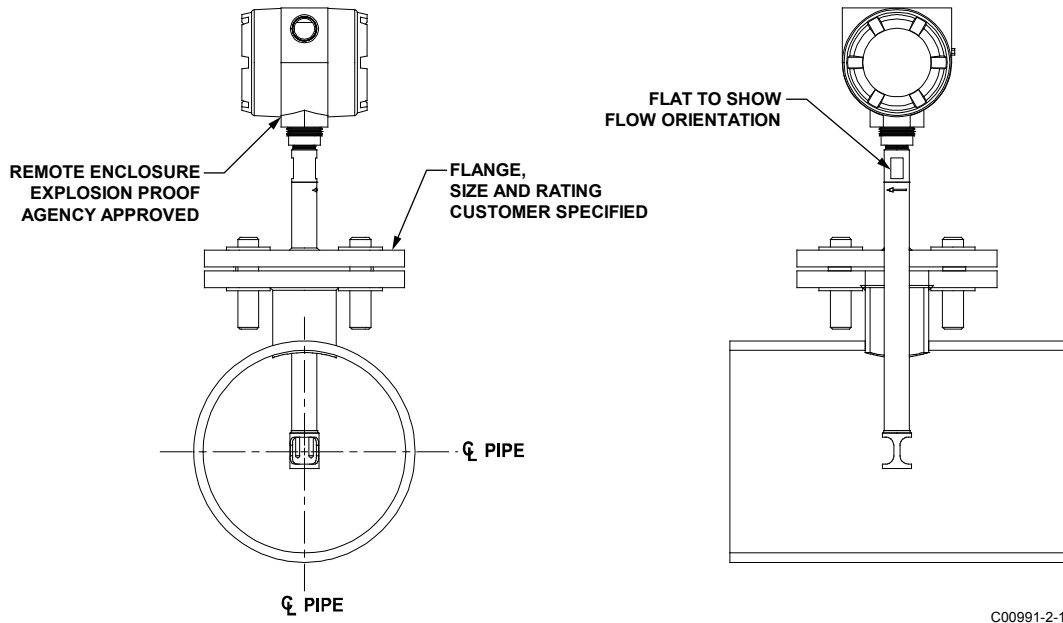

**Figure 3 – Example Flange Mount Installation**

### NPT Pipe Thread Mount

The pipe thread configuration is shown in [Figure 4](#) below. Apply sealant compatible with the process media to male threads. Carefully insert into process mounting coupling. Tighten the flow element until snug and continue until flat and flow direction arrow are aligned with process flow.

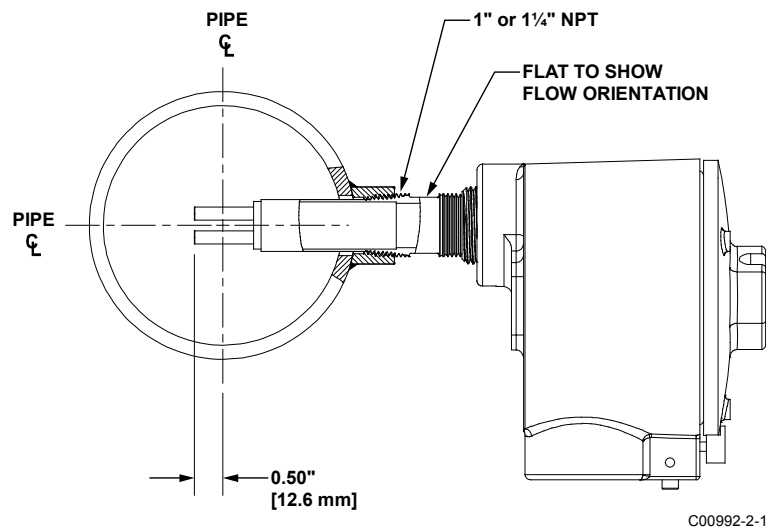

**Figure 4 – Example NPT Pipe Thread Mount Installation**

**Retractable Packing Gland Mounting**

A retractable low and medium pressure packing gland, with 1/4" MNPT threads or ANSI/DIN flange, and graphite or Teflon packing, is a process connection option. FCI single point flow meters are calibrated at the centerline of the process pipe. The flow element is properly mounted when the tip of the flow element is located .50 inches (13 mm) past the pipe centerline. Follow the below steps to install/retract instruments with the retractable packing gland option (as applicable to your configuration, also follow the pipe thread or flange mount procedures as described in previous sections).

*Insertion/Installation Procedure*

1. The scale etched on the side of the insertion probe indicates the length to the tip of the flow element. Calculate the insertion depth using the equation, variables, and Figure 5 below.

*ID* = Inside Diameter of Pipe

*T* = Pipe Wall Thickness

*C* = Mounting Coupling with Optional Ball Valve and Installed Packing Gland Length

$$INSERTION\ DEPTH = .50\ inches + \left(\frac{I.D.}{2}\right) + T + C$$

INSERTION DEPTH = \_\_\_\_\_

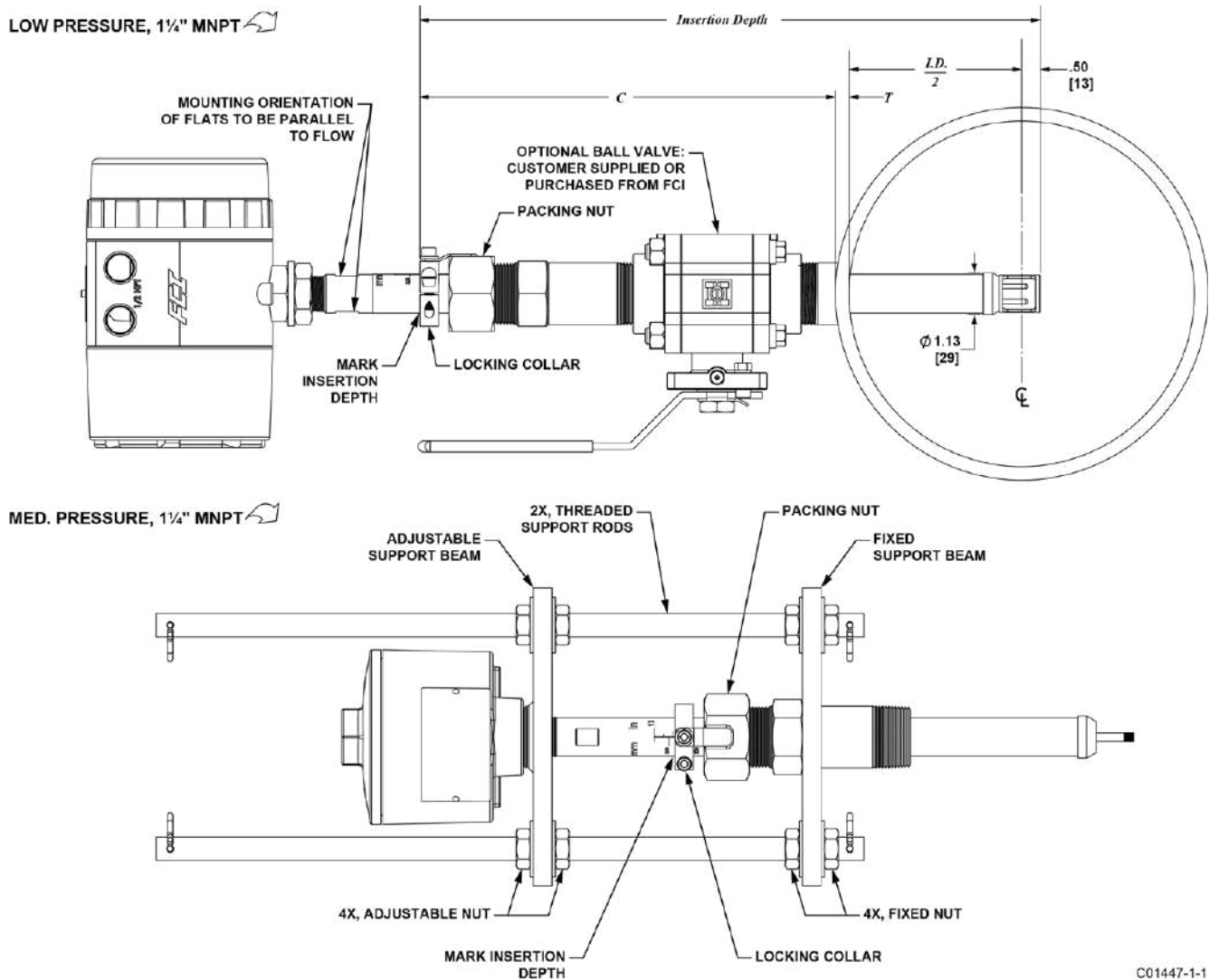

**Figure 5 – Retractable Packing Gland Installation**

C01447-1-1

2. Mark the insertion pipe at the calculated insertion depth.
3. **Ball Valve Applications Only:** If a ball valve is required, install the ball valve to the process mounting coupling. Close the ball valve to prevent the process media from leaking out when installing the packing gland with the process line pressurized.
4. Apply the proper thread sealant compatible with the process media to the male threads of the packing gland. Fully retract the insertion probe into the cavity of the packing gland and install the packing gland into the process mounting coupling or ball valve as described in the previous sections: [Flange Mount](#) and [NPT Pipe Thread Mount](#). **If a ball valve is not used, make sure to first depressurize the process line before installing.**
5. Tighten the packing nut until the internal packing is tight enough to prevent excess process leakage, but also allow the insertion probe to be inserted into place. For ball valve applications, open the ball valve after the packing nut has been tightened.

**Caution:** For applications where the process media is pressurized to greater than 50 psig (3.5 barg), a medium pressure packing gland assembly with support rods or FCI retractor tool, part no. 026854-01, must be used to safely insert the probe into the process. The FCI packing gland and retractor tool are rated to a maximum pressure of 500 psig (35 barg). For instructions on how to install the flow meter using the FCI retractor tool, see step 7.

6. **Manual Flow Element Insertion: Insertion by Hand (Pressure: 50 psig [3.5 barg] max.) or Using Med. Pressure Packing Gland Assembly with Support Rods (Pressure: 500 psig [35 barg] max.)**

- a. Align the orientation flat and flow arrow parallel to the flow direction and proceed to insert the flow element into the process media pipe up to the insertion depth mark. For medium pressure packing gland, use the adjusting nuts on the threaded rods to pull the flow element up to the insertion depth mark, and then tighten the adjustable nuts against the adjustable support beam to lock the insertion probe into place. Make sure to move the adjustable nuts at the same time (equally) to prevent the probe from bending and damaging the packing gland.
- b. Tighten the packing nut another ½- to 1-turn tight (approximately 65-85 ft-lbs [88-115 N-m]) until the packing has created a full seal.
- c. Ensure the locking collar is properly secured to the back of the packing gland. Torque the two ¼"-28 socket head cap screws on the locking collar to 94 in-lbs [11 N-m] using a 3/16" hex key.

7. **Flow Element Insertion Using FCI Retractor Tool 026854-01 (Pressure: 500 psig (35 barg) max.)**

- a. Place the flow element into the top and bottom brackets of the FCI retractor tool as shown in [Figure 6](#).
- b. Align the orientation flat and flow arrow parallel to the flow direction. Position the top bracket close to the orientation flat as shown in [Figure 6](#).
- c. Secure the top and bottom bracket clamps to the flow element using the eight no. 8-32 screws provided as shown in [Figure 6](#). Torque these screws to 20 in-lbs [2 N-m] minimum.
- d. The retractor tool has, on both ends, a 3/8" drive socket that engages the retractor to move the flow element in or out. Once the flow element has been properly secured, open the ball valve and insert the flow element by using either a hand wrench or a drill to rotate either drive socket in the appropriate direction for **insertion** as shown in [Figure 6](#). Observe the **Warning** below if using an electric drill. Insert the flow element up to the insertion depth mark and tighten the packing nut another ½ to 1 turn tight (approximately 65 to 85 ft-lbs [88-115 N-m]) until the packing has created a full seal.

**Warning:** Take note of your environment if using an electric drill to operate the retractor. Do not use an electric drill in an explosive environment as the drill could create a spark and cause an explosion.

- e. Ensure the locking collar is properly secured to the back of the packing gland. Torque the two ¼"-28 socket head cap screws on the locking collar to 94 in-lbs [11 N-m] using a 3/16" Allen wrench (hex key).

**Note:** After inserting the probe, you have the option to leave the retractor tool in place to ease future probe removal. If the retractor tool is removed, make sure to reinstall it before retracting the probe at pressures > 50 psig. Since the packing gland itself has a 500 psig rating, the probe remains securely in place with the retractor off.

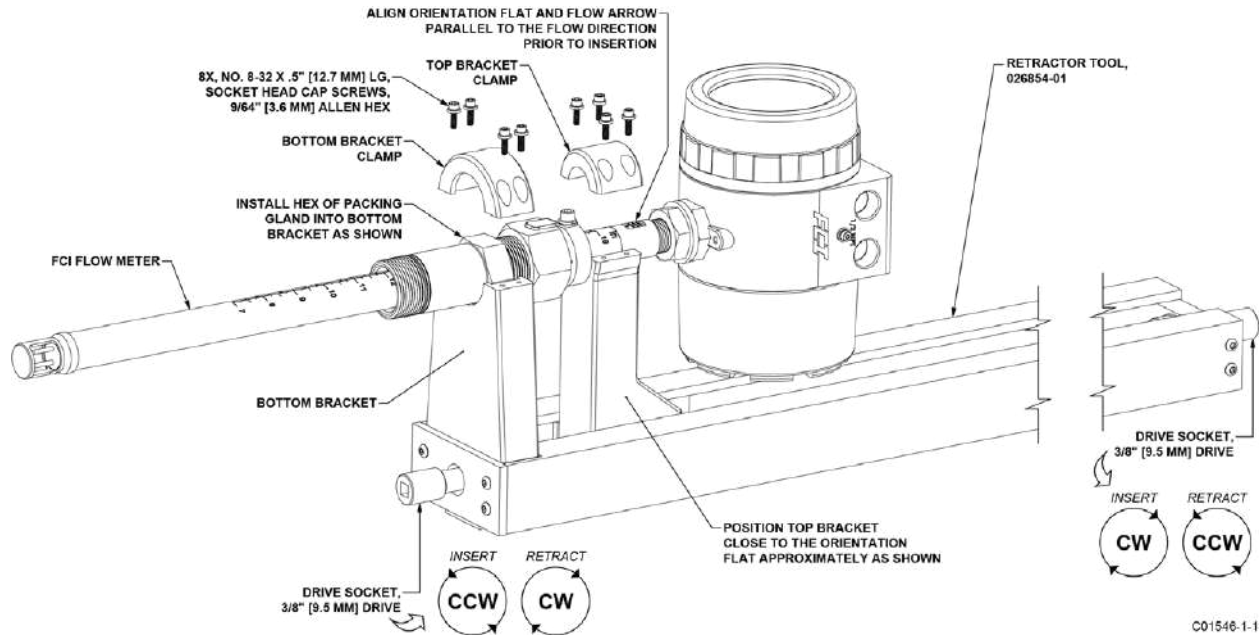

**Figure 6 – Flow Element Installation Using FCI Retractor Tool 026854-01**

*Retraction/Removal Procedure*

**Caution:** For applications where the process media is pressurized to greater than 50 psig (3.5 barg), FCI retractor tool, part no. 026854-01, must be used to safely retract the probe from the process (does not apply to applications using the medium pressure packing gland assembly with support rods). For applications where the process media is pressurized to equal to or less than 50 psig (3.5 barg), the flow element can be safely guided by hand. When using hands to restrain the retraction, be prepared for a rapid pressure impulse of the flow element. Check first that there are no objects directly behind the flow element as the insertion probe may retract very quickly.

**1. Manual Flow Element Retraction: Retraction by Hand (Pressure: 50 psig [3.5 barg] max.) or Using Med. Pressure Packing Gland Assembly with Support Rods (Pressure: 500 psig [35 barg] max.)**

- a. Loosen the socket head cap screw on the side of the locking collar. See Figure 7 below.

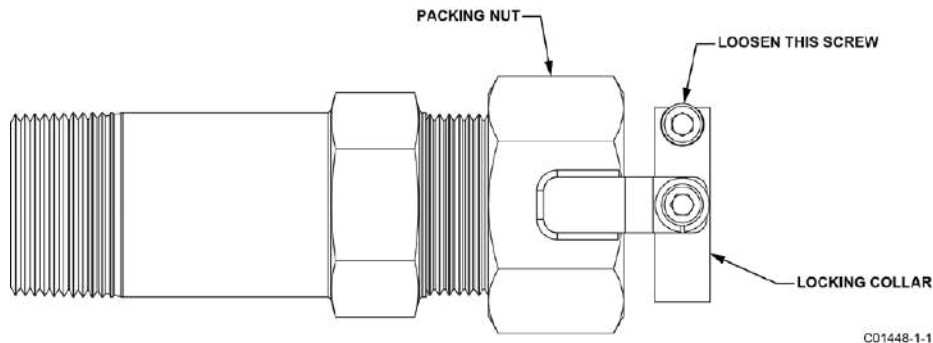

**Figure 7 – Packing Gland Locking Collar**

- b. **Low Pressure** (max. 50 psig [3.5 bar(g)]): Slowly loosen the packing nut until the insertion probe begins to retract. Use hands as needed to help control the retraction. If the probe does not begin to retract itself, gently shake and pull the insertion probe until the flow element has been fully retracted into the packing gland.

**Medium Pressure** (max. 500 psig [35 bar(g)]): Loosen the two nuts at the top of the adjustable support rods so that they lie slightly above the top support beam. Slowly loosen the packing nut until the insertion probe begins to retract. The insertion probe will come to rest when the support beam at the top of the probe makes contact with the two top adjustable nuts. Continue to slowly loosen the two top nuts until the insertion probe has fully retracted into the body of the packing gland. If the insertion probe does not retract when moving the two top nuts, continue loosening the packing nut until retraction resumes. Make sure to move the two top adjustable nuts at the same time (equally) to prevent the probe from bending and damaging the packing gland. To lock the probe in a retracted state, tighten the top and bottom adjustable nuts against the top support beam.

- c. For ball valve applications: Close the ball valve immediately after retraction to seal off the process. After closing the ball valve it is then safe to remove the flow element from the back end of the ball valve. **If a ball valve is not being used, make sure to first depressurize the process line before removing the flow element.**

## 2. Flow Element Retraction Using FCI Retractor Tool 026854-01 (Pressure: 500 psig (35 barg) max.)

- a. Install the FCI retractor tool to the flow element as described in [Insertion/Installation Procedure](#), page 10, steps 'a,' 'b,' and 'c.'
- b. Loosen the socket head cap screw on the side of the locking collar. See [Figure 7](#) above.
- c. Slowly loosen the packing nut until the load shifts to the top bracket of the retractor tool (approximately 1-1.5 turns).
- d. The retractor tool has, on both ends, a 3/8" drive socket that engages the retractor to move the flow element in or out. Use a hand wrench or a drill to rotate either drive socket in the appropriate direction for **retraction** as shown in [Figure 6](#). Observe the **Warning** below if using an electric drill. Retract the flow element until the sensor head has been fully retracted into the cavity of the packing gland.

**Warning:** Take note of your environment if using an electric drill to operate the retractor. Do not use an electric drill in an explosive environment as the drill could create a spark and cause an explosion.

- e. Immediately after retraction, close the ball valve to seal off the process.
- f. After the ball valve has been closed, it is safe to remove the flow element from the back end of the ball valve.

**ST80L In-Line Process Connection**

The in-line ST80L flow element assembly can be threaded, flanged or butt weld mounted to the process piping. The specific type in-line process connection is customer-specified on the order information sheet (OIS). See [Figure 8](#) below.

Mount the sensor to the process piping per the application piping requirements. Verify the flow direction arrow is pointed in the correct direction. After the sensor head has been located correctly and tightened into place, verify the process seal does not leak by slowly applying pressure until the normal operation pressure is applied. Check for leaks at the process connection boundary.

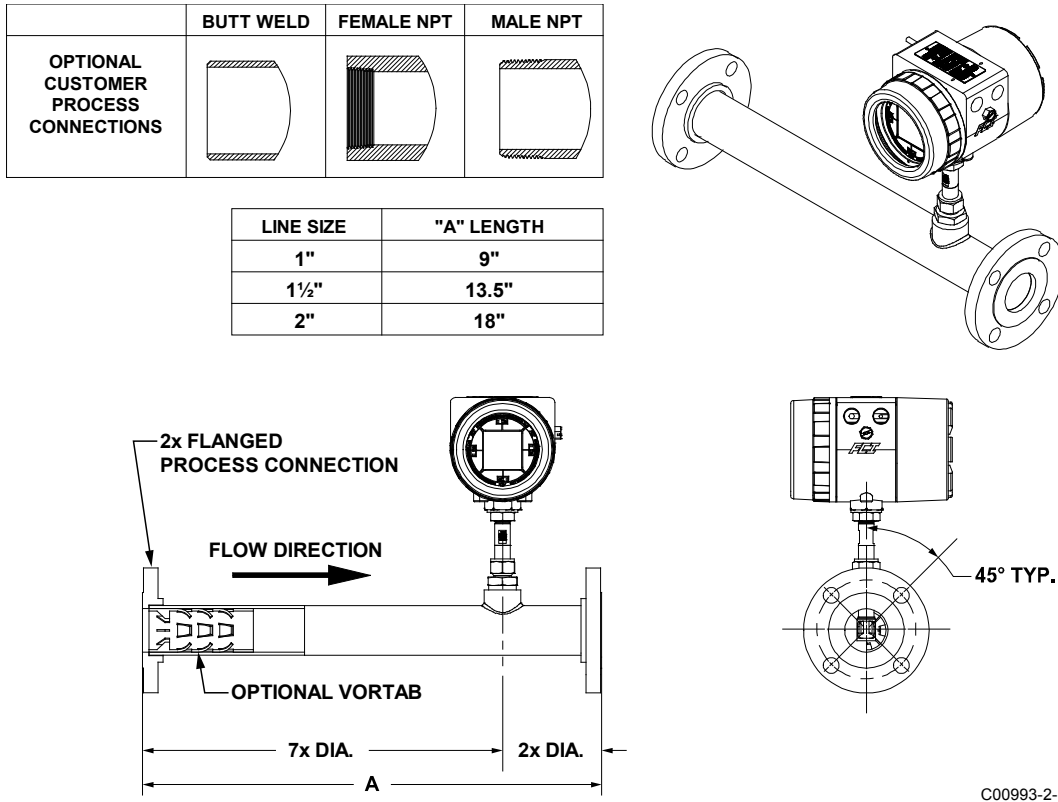

**Figure 8 – ST80L Process Connection**

**Installation of Probe with Moisture/Rain Shield**

For sensor probes equipped with a moisture or rain shield, position the probe/shield assembly within the pipe as shown in [Figure 9](#). The drawing shows the orientation of the moisture/rain shield relative to the flow direction, the correct position of the probe/shield assembly relative to the pipe centerline, and the minimum pipe size. The moisture shield prevents build-up of moisture in the sensor head for wet gas applications. The rain shield shields the sensor from rain falling into an open vertical pipe/stack in upward vertical flow applications.

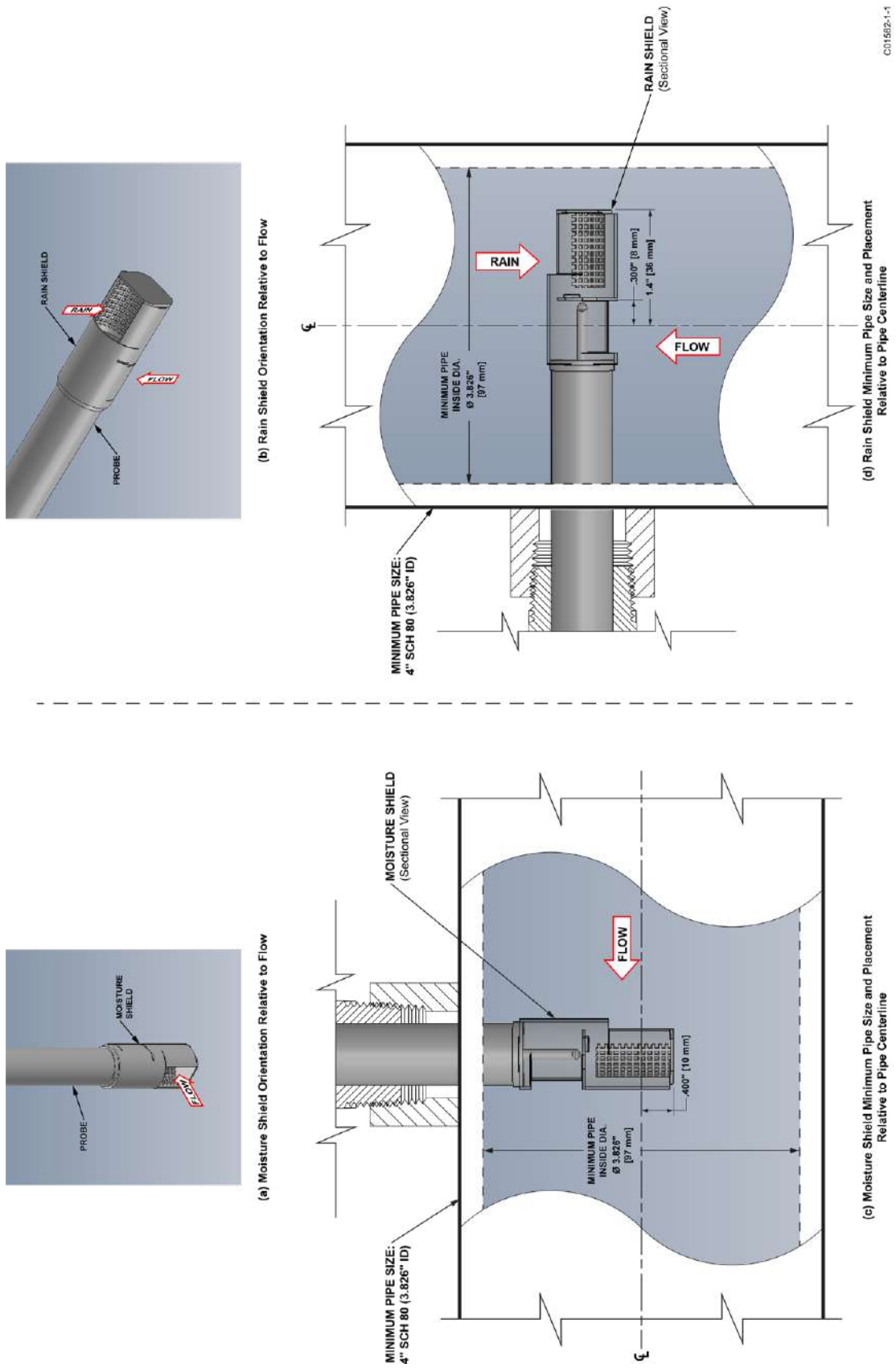

C01562-1-1

Figure 9 – Installation of Sensor Probe with Moisture/Rain Shield

### Flow Transmitter Electronics Installation

The instrument electronic transmitter can be an integral part of the flow element or it can be mounted remotely using a shielded cable between the flow element and the electronics.

Use power wiring with a minimum 90 °C rating.

#### ESD Precautions

**Caution:** FCI flow meters contain static-sensitive devices. To avoid damage to the instrument observe the ESD precautions listed below before opening the instrument for wiring.

- Use a wrist band or heel strap with a 1 MΩ resistor connected to ground.
- Use a static conductive mat on the work table/floor with a 1 MΩ resistor connected to ground when working on the instrument in a shop setting.
- Connect the instrument to ground.
- Apply antistatic agents such as Static Free made by Chemtronics to hand tools used on the instrument.
- Keep high static-producing items away from the instrument.

The above precautions are minimum requirements. The complete use of ESD precautions can be found in the U.S. Department of Defense Handbook 263.

#### Integral Electronics

The integral electronics package is mounted during the flow element installation process. The integral electronics can be rotated  $\pm 180$  degrees on the top of the flow element insertion pipe. This is done by loosening the lock nut at the base of the enclosure and rotating the enclosure to the preferred orientation. **Do not rotate the electronics enclosure more than  $\pm 180$  degrees. Damage to internal wiring may result from over-rotating the enclosure.**

Lock Nut Torque Specification: 30-35 ft-lbs (40-47 N-m)

Provide integral electronics with additional support/bracing in applications where excessive vibration is present. A mounting bracket is available from FCI to support the electronics when additional support is required. See [Figure 10](#) below.

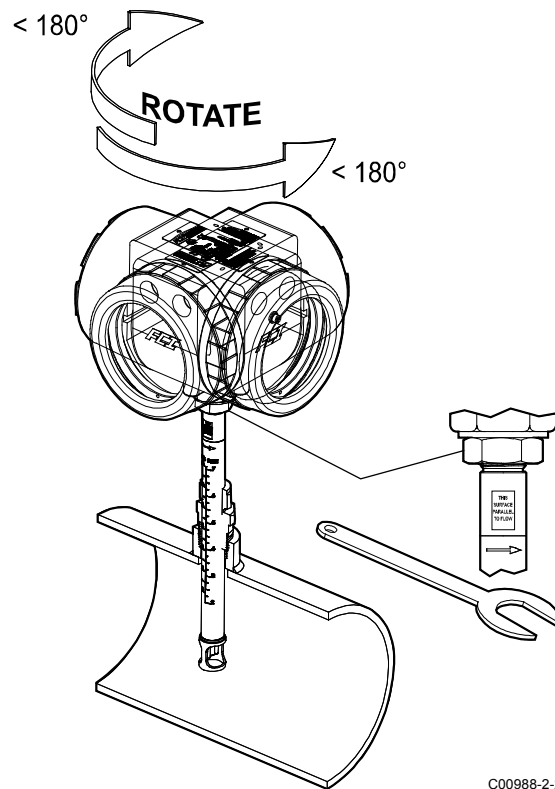

Figure 10 – Integral Electronics Installation (Compression Fitting Shown)



### Remote Electronics

A mounting bracket is supplied when the transmitter is ordered for remote mounting. The bracket mounting details are shown in [Figure 11](#) below. Refer to the outline installation drawings in Appendix A for additional mounting details. The electronics can be easily mounted on a wall or pipe. The mount bracket is designed for .25 inch or M6 mounting hardware. Securely mount the electronics to cement or structural support columns or beams. Mounting to plaster is not recommended and does not meet system approval requirements.

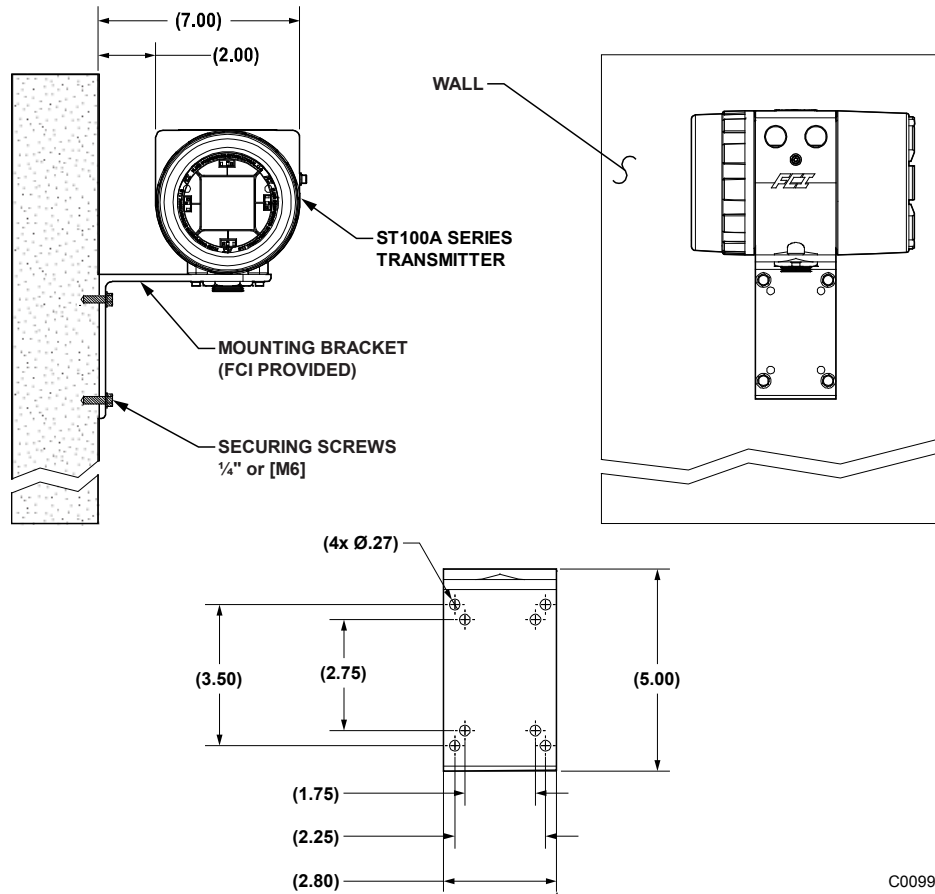
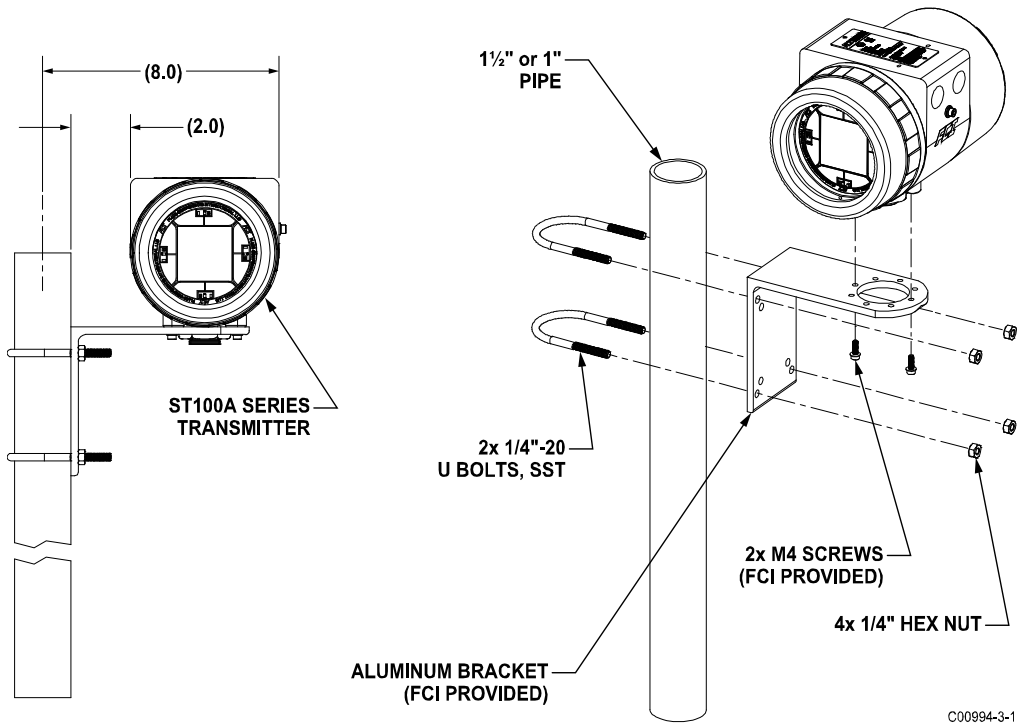

Figure 11 – Remote Installation, Mounting Bracket on Wall

*Remote Pipe Mounting*

Refer to the figures below for remote transmitter pipe mounting details.



**Figure 12 – Remote Installation, Mounting Bracket on 1" – 1 1/2" Pipe**

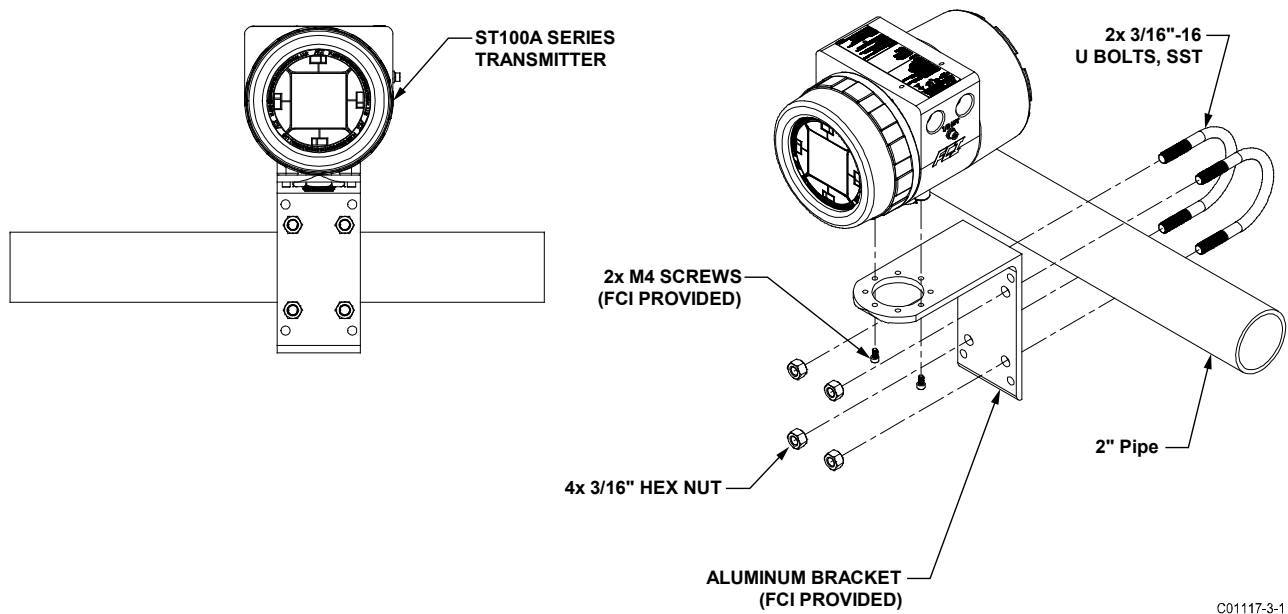

**Figure 13 – Remote Installation, Mounting Bracket on 2" Pipe**

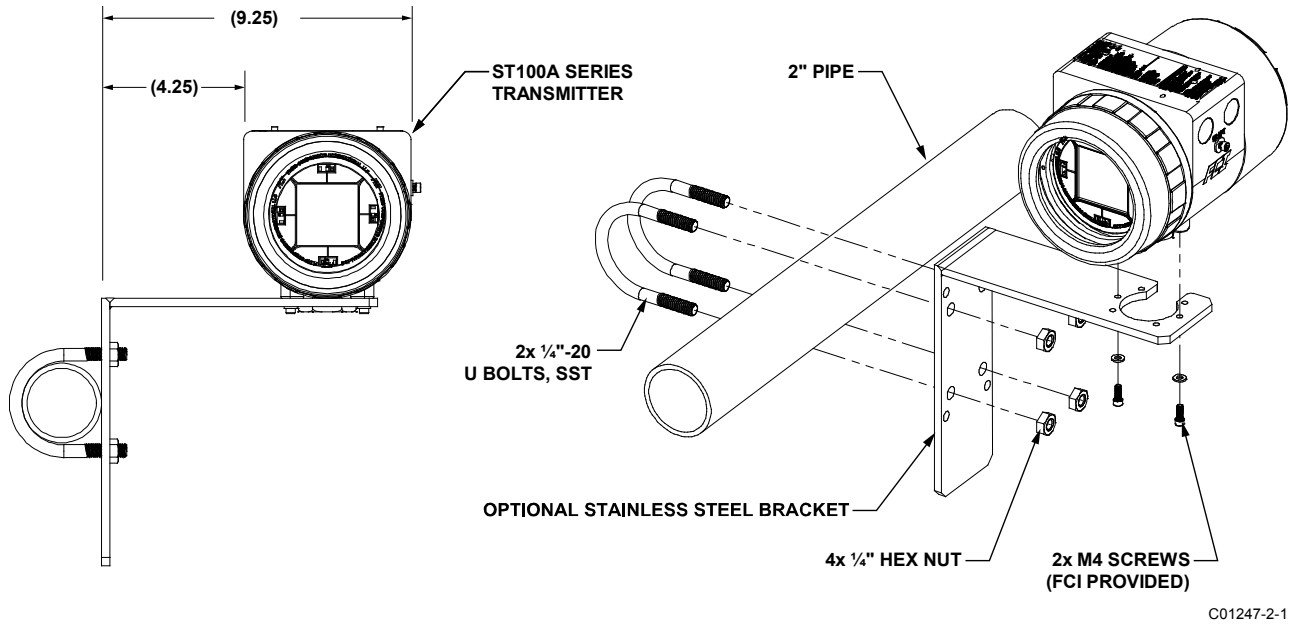
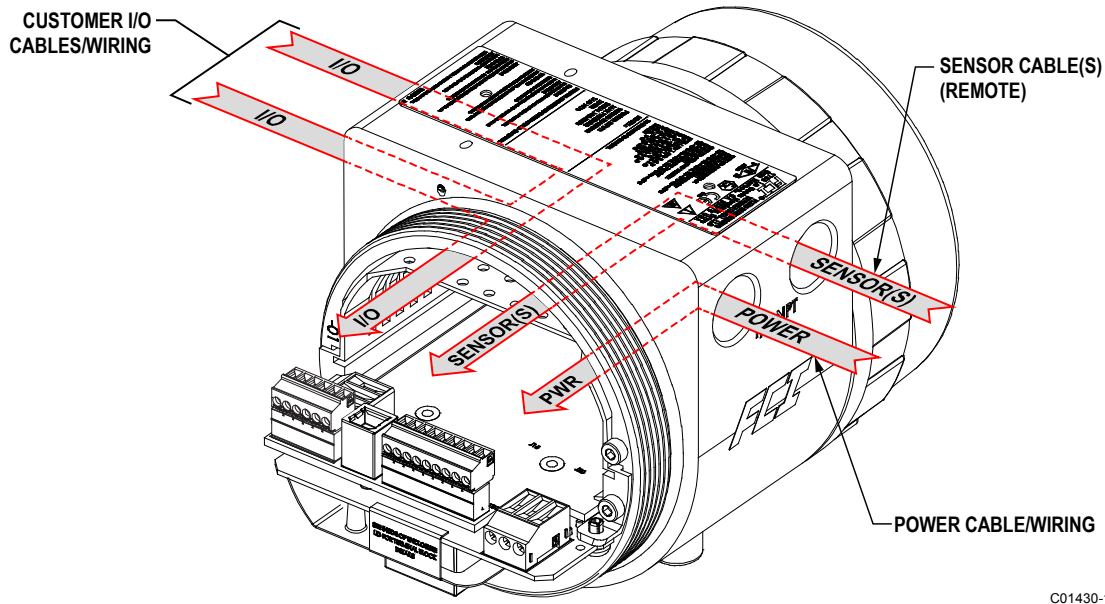

Figure 14 – Remote Installation, Optional Stainless Steel Bracket on 2" Pipe

**Instrument Wiring**

The flow transmitter can be powered by 85 – 265 VAC or 24 VDC as specified in the instrument specification. The electronics cannot be configured to switch between AC and DC power. **For 220/265 VAC installations, a neutral reference circuit must be used.**

All cable glands and conduit fittings must meet or exceed the area approval rating where the instrument is being installed. The base electronics enclosure has two wiring ports (1/2"-14 NPT or M20 x 1.5) on both sides of the enclosure body (local enclosure options excluded). The recommended instrument wiring routing is shown in [Figure 15](#) below.



**Figure 15 – Recommended Wiring Routing, Base Electronics Enclosure**

[Table 2](#) below shows the smallest copper wire (maximum AWG number) that can be used for the listed cabling. Contact FCI concerning greater distances than those listed in the chart. Refer to [APPENDIX A](#), page 93 for additional wiring/cabling information.

**Table 2 – Interconnecting Cable Minimum Conductor Size**

Connection	Maximum Distance for AWG [mm <sup>2</sup> ]					
	10 ft. (3 m)	50 ft. (15 m)	100 ft. (30 m)	250 ft. (76 m)	500 ft. (152 m)	1000 ft. (305 m)
Power AC or DC	22 [0.3255]	22 [0.3255]	22 [0.3255]	20 [0.5176]	18 [0.8230]	16 [1.3087]
Flow Element (8-Cond. Shielded)	24 [0.2047]	24 [0.2047]	24 [0.2047]	22 [0.3255]	22 [0.3255]	18 [0.8230]
STP Flow Element (10-Cond. Shielded)	22 [0.3255]	22 [0.3255]	22 [0.3255]	22 [0.3255]	22 [0.3255]	18 [0.8230]
Analog Out (HART)	16-30 [1.3087-0.0509]	16-30 [1.3087-0.0509]	16-30 [1.3087-0.0509]	16-30 [1.3087-0.0509]	16-30 [1.3087-0.0509]	16-30 [1.3087-0.0509]
Modbus	RS485 (14-30 AWG) [2.0809-0.0509]					
FOUNDATION Fieldbus	FF-844 H1 (14-30 AWG) [2.0809-0.0509]					
PROFIBUS	RS485 (14-30 AWG) [2.0809-0.0509]					

- Notes: 1. Requires a shielded cable. The shield is connected to the GND in the transmitter enclosure. The other end of the shield is left floating (no connection to the flow element enclosure).
2. Transmission speed determines maximum cable length and vice versa: **9.6 kbps** = 3940 ft/1200 m, **19.2 kbps** = 3940 ft/1200 m, **45.45 kbps** = 3940 ft/1200 m, **93.75 kbps** = 3940 ft/1200 m, **187.5 kbps** = 3280 ft/1000 m, **500 kbps** = 1310 ft/400 m, **1500 kbps** = 656 ft/200 m, **3000 kbps** = 328 ft/100 m, **6000 kbps** = 328 ft/100 m, **12000 kbps** = 328 ft/100 m.

### Accessing the I/O Connectors

**Warning:** Turn instrument power OFF before wiring the instrument.

**Caution:** Use caution inserting wires into electronics housing. The metal ends can damage circuit boards.

**Remote Units:** Avoid pulling, or inadvertently tugging, the remote cable when wiring the instrument. The sensor connector/circuit board can be easily damaged by excess pulling of the remote cable.

**Caution:** Observe ESD precautions when wiring the instrument. Refer to [ESD Precautions](#), page 16.

To access the instrument's connection terminals first use a .050" hex key to loosen the set screw locking the enclosure body blind lid. Then unscrew the blind lid from the enclosure. Carefully pull the power and signal wires through the port to avoid damaging the electronics.

Figure 16 below shows the location of the ST80/ST80L I/O connectors as well as the lid set screw access holes in the enclosure body.

Connect wiring as described in the following paragraphs. Reinstall the blind lid when done making the connections: Tighten the lid one full turn past the point where the O-ring makes contact with the lid, and then tighten the lid set screw to lock the lid (set screw must not protrude from its threaded hole after tightening).

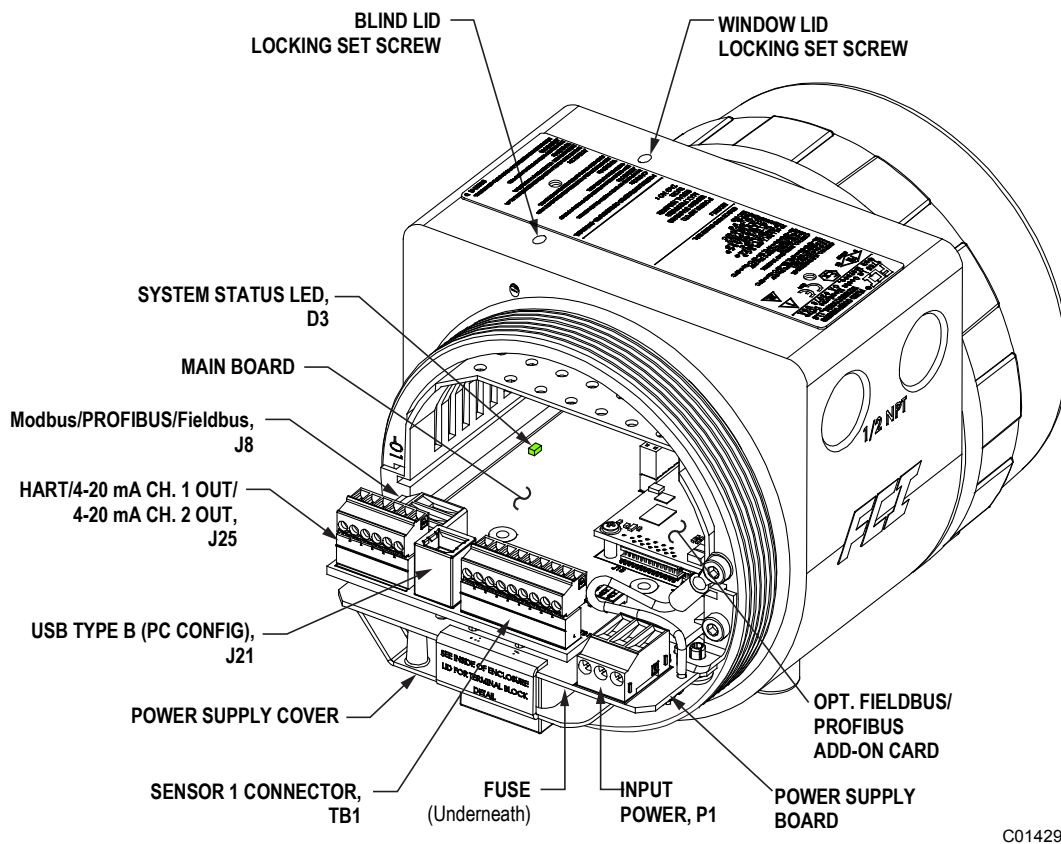

C01429-1-1

Figure 16 – ST80/ST80L I/O Connector Locations

**Electronics Enclosure Label**

Affixed to the inside of the blind lid is a label that identifies the ST80/ST80L's jacks and connectors (with terminal assignment). See [Figure 17](#) below. Use this label as a guide when wiring the instrument. Note that the PCB silkscreen also provides connector identification.

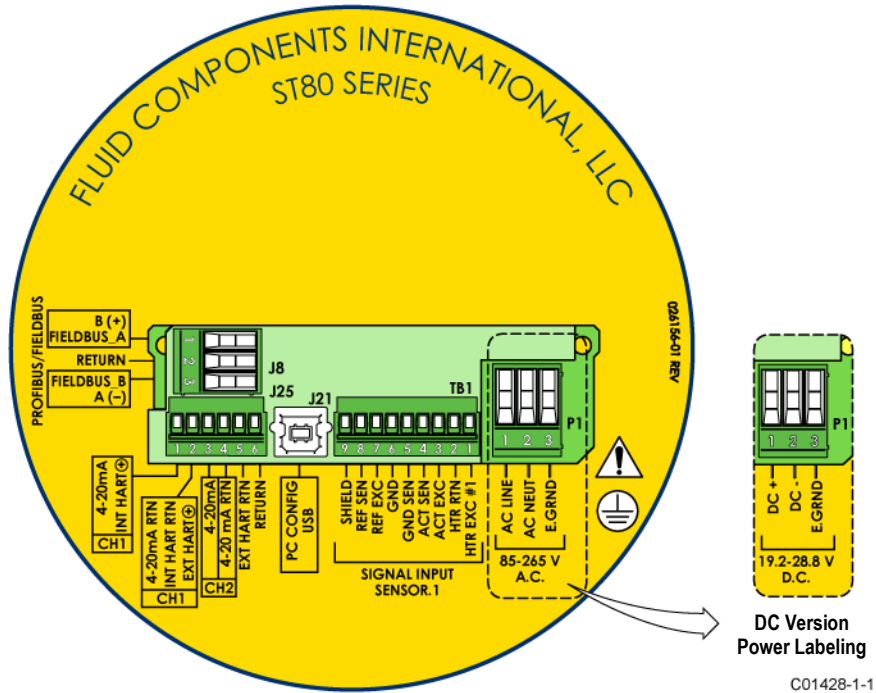

**Figure 17 – ST80/ST80L Electronics Enclosure Label**

**Configuration Jumpers/DIP Switch**

When wiring the instrument for Modbus/Fieldbus/PROFIBUS make sure that the instrument is properly configured as shown in [Figure 18](#) below. Refer to [Modbus Connections](#) on page 27 and [Foundation Fieldbus/PROFIBUS Connections \(Option\)](#) on page 28 for details.

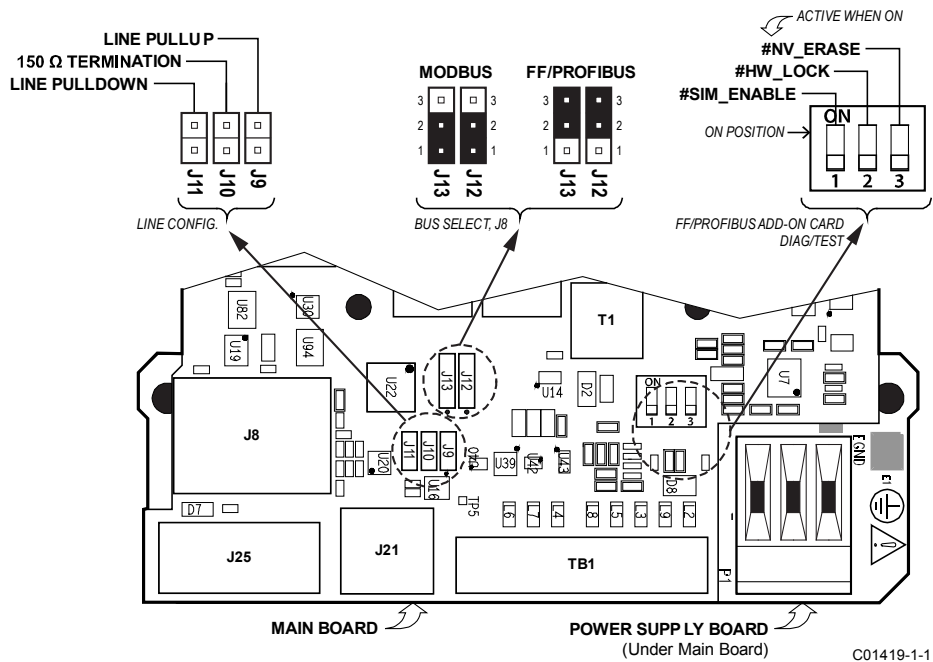
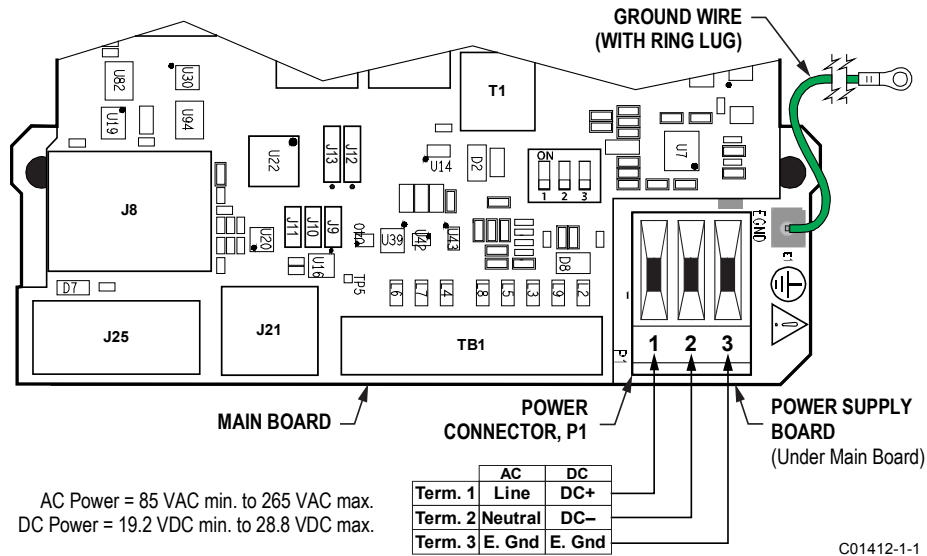

**Figure 18 – Bus Configuration 2 mm Jumper Headers and DIP Switch**

**Input Power**

**Warning:** Install an AC line disconnect switch with fuse or breaker between the power source and the flow meter. Always disconnect power before performing maintenance on wiring.

Connect input power to the 3-position Phoenix connector **P1** on the power supply board as shown in [Figure 19](#) below. The power connector accepts 24–12 AWG (0.2 mm<sup>2</sup> – 1.5 mm<sup>2</sup>) wire (refer to [Table 2](#), page 20 for wire size vs. length info). It is recommended that wiring have a flammability rating of UL 2556 VW-1 or equivalent.



**Figure 19 – Input Power Wiring**

Before connecting the power wires to connector P1, install the ferrite core clamp onto the power wiring as shown in [Figure 20](#) below. Then insert the stripped power wire ends into the appropriate P1 connector terminals. The ferrite core clamp (supplied with the instrument as ferrite kit FCI p/n 023638-02) protects the instrument against the adverse effects of EMI/RFI electrical noise.

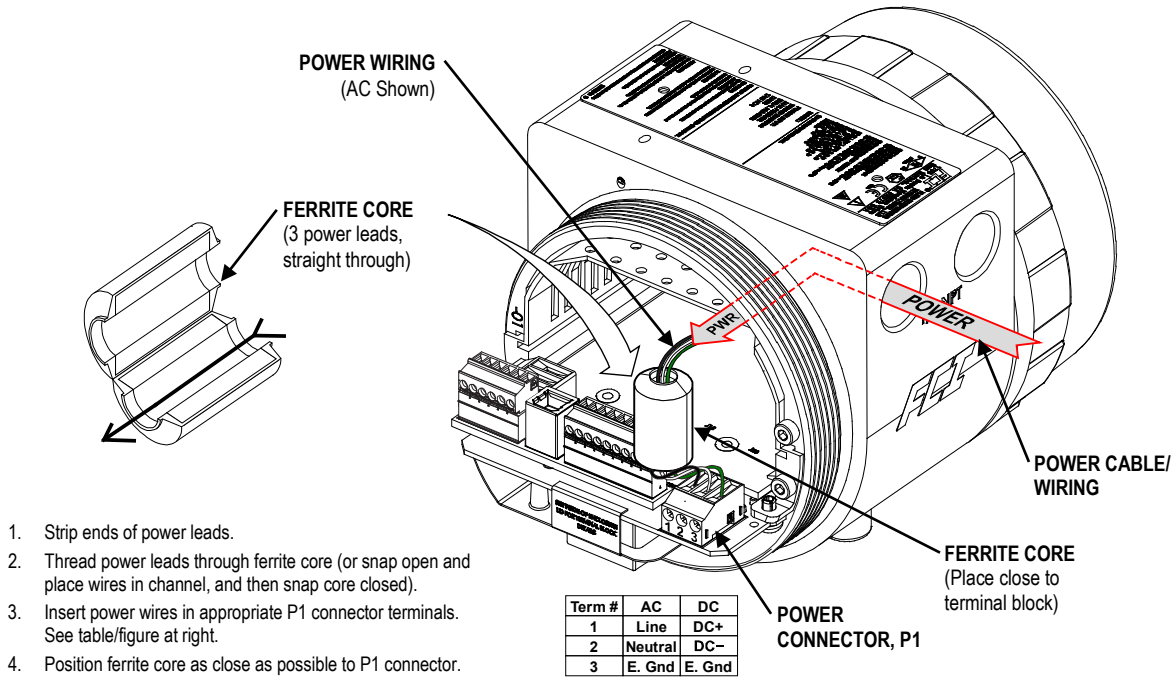

**Figure 20 – ST80/ST80L Ferrite Core Installation**

Power overload protection is provided by a clip-mounted SMT fuse. Refer to [Power Fuse Replacement](#), page 78 (MAINTENANCE section) for fuse replacement details.

**Flow Element Connections**

**Note:** The flow element in all integral units is pre-wired at the factory. The information in this section applies to remote configuration units only.

See the appropriate wiring diagram in [APPENDIX A](#) for interconnect wiring between the flow element and remote electronics. Use an 8-conductor shielded cable for the external flow element input. The flow meter will not operate properly without these connections. To avoid inaccurate flow meter readings make sure the ACT and REF wires are not reversed.

Referencing [Figure 16](#) connect the ST80/ST80L flow element sensor wires to the detachable 9-position connector plug **TB1** on the main board. See [Figure 21](#) below. The connector plug accepts 28-16 AWG (0.14 mm<sup>2</sup> - 1.5 mm<sup>2</sup>) wire (refer to [Table 2](#), page 20 for wire size vs. length info). Connect the flow element cable shield to the connector plug's GND terminal (terminal #9). Leave the other end of the shield floating (no connection to the flow element enclosure). Connect the flow element sensor to the plug as follows:

1. Remove connector plug from board (pull straight out).
2. Route sensor wires through remote enclosure's wiring port/cable gland. Refer to [Figure 15](#), page 20.
3. Strip wire ends (0.27 in [7 mm]) and insert into appropriate plug terminals as shown in [Figure 21](#) below. Make sure to tighten each terminal screw securely (max. torque: 2.2 inch-lbs [0.25 N-m]).
4. After all terminations are made plug connector block back into its header socket on the board.

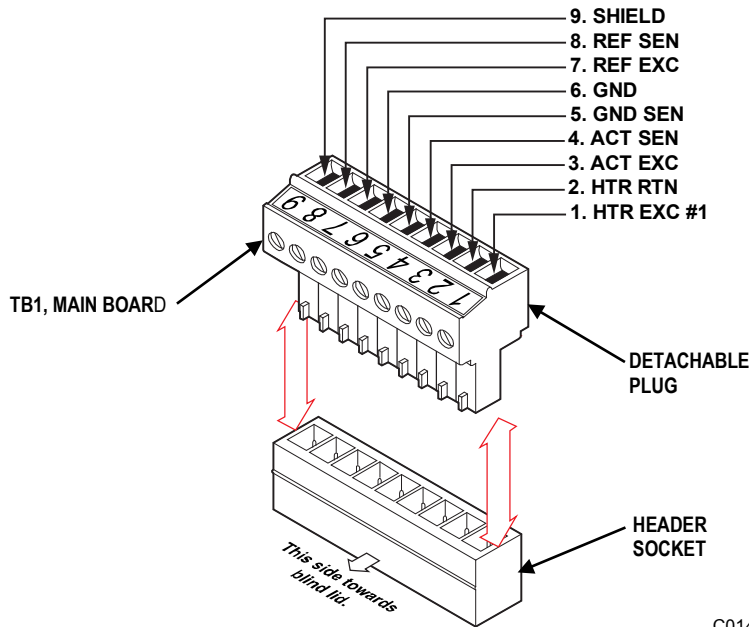

C01431-1-1

**Figure 21 – Flow Element Connections, TB1**



## HART Connections

Referencing [Figure 16](#) connect the installation HART wiring to the **J25** Phoenix connector. Similar to flow element connector TB1 the **J25** connector is a detachable plug that plugs into the header socket on the board. Use the appropriate **J25** connector terminals depending on your application as shown in [Figure 22](#) below. The connector plug accepts 28-16 AWG (0.14 mm<sup>2</sup> - 1.5 mm<sup>2</sup>) wire.

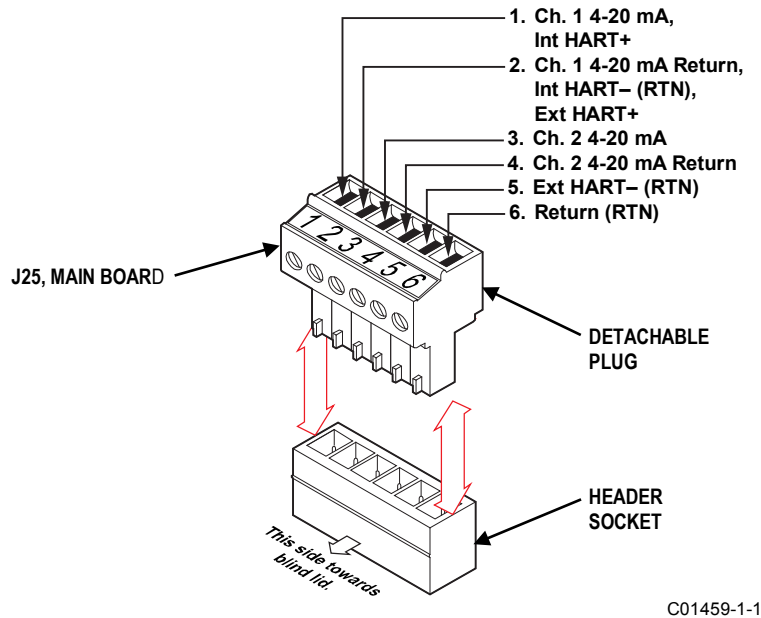

**Figure 22 – HART and Ch. 1 & Ch. 2 4-20 mA Connections, J25**

- **Single Connection** – The instrument supplies power to the loop and controls the current as well. For this application connect HART+ to J25-1 (INT HART+) and HART- to J25-2 (CH1/INT HART RTN). This is the default 4-20 mA Ch. 1 output even if HART is not used.
- **Network (Multidrop) Connection** – The instrument receives loop power from the network, and controls the current. For this application connect external HART+ to J25-2 (EXT HART+) and external HART- to J25-4 (EXT HART RTN).

The block diagram in [Figure 23](#) below shows the single connection and multidrop HART setups. Use a 250 Ω 1%, ≥ 0.3 W resistor as shown in the diagram below **only** if the external HART interface/wiring does not have this resistance built-in (HART requires a minimum loop resistance of 230 Ω).

### CABLING RECOMMENDATION

Use a shielded, twisted-pair instrument grade wire (min. 24 AWG for runs less than 5000 ft/1500 m; min. 20 AWG for longer distances). The RC value of the wire (*Total Resistance x Total Capacitance*) must be less than 65 μs (not a concern for point-to-point topology with a run less than 328 ft/100 m). A cable designed for HART/RS-485 such as Belden 3105A is recommended for complex setups or particularly long runs or both.

**Note:** The HART communications digital signals are superimposed on top of the channel #1 current loop (4-20 mA) output. When HART communications is in use, the HART current loop channel #1 **MUST** be configured as FLOW to comply with the HART protocol. The channel #1 current loop output is configured as FLOW by default at the factory.

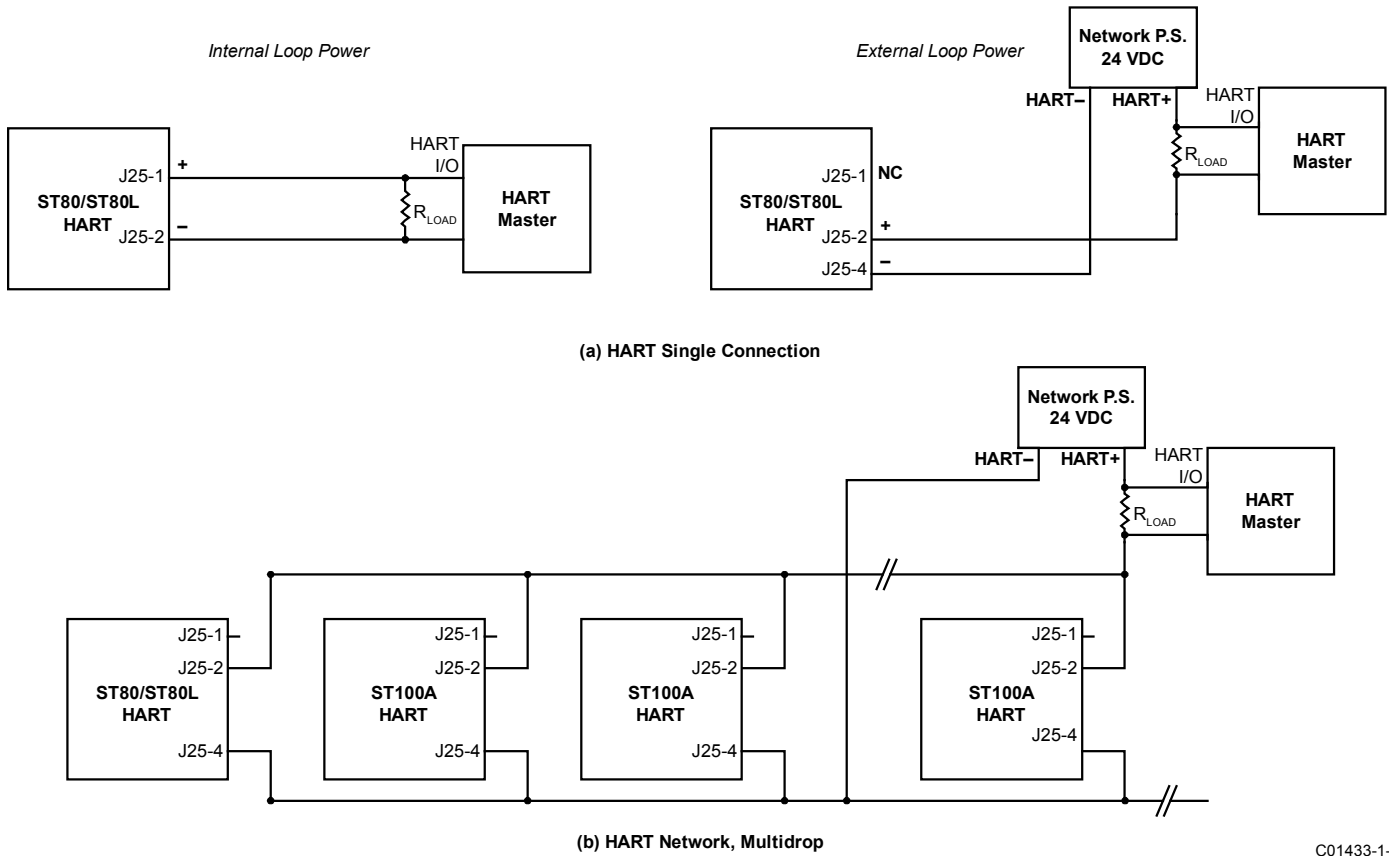

C01433-1-1

**Figure 23 – Single Connection and Multidrop HART Setups**

**4-20 mA Output Connections**

The ST80/ST80L is provided with two 4-20 mA current loop channels as standard via the **J25** Phoenix connector terminals. Refer to [Figure 16](#) and [Figure 22](#). Similar to flow element connector TB1 the **J25** connector is a detachable plug that plugs into the header socket on the board. The connector plug accepts 28-16 AWG (0.14 mm<sup>2</sup> - 1.5 mm<sup>2</sup>) wire (refer to [Table 2](#), page 20 for wire size vs. length info).

Ch. 1 is dedicated to HART (see above for connection details). Connect the instrument's second 4-20 mA output (Ch. 2, J25-3) as required for your application. Use any RTN terminal (e.g., J25-4 through J25-6) for the 2nd channel current loop return.

**Modbus Connections**

Referencing [Figure 16](#) connect the Modbus device/network to Phoenix connector **J8** on the main board. Note that the **J8** connector is also used for FOUNDATION Fieldbus and PROFIBUS wiring (only one interface can be active at a time). See [Figure 24](#) below. Connector **J8** accepts 24–12 AWG (0.2 mm<sup>2</sup> – 1.5 mm<sup>2</sup>) wire (refer to [Table 2](#), page 20 for wire size vs. length info). It is recommended that wiring have a flammability rating of UL 2556 VW-1 or equivalent.

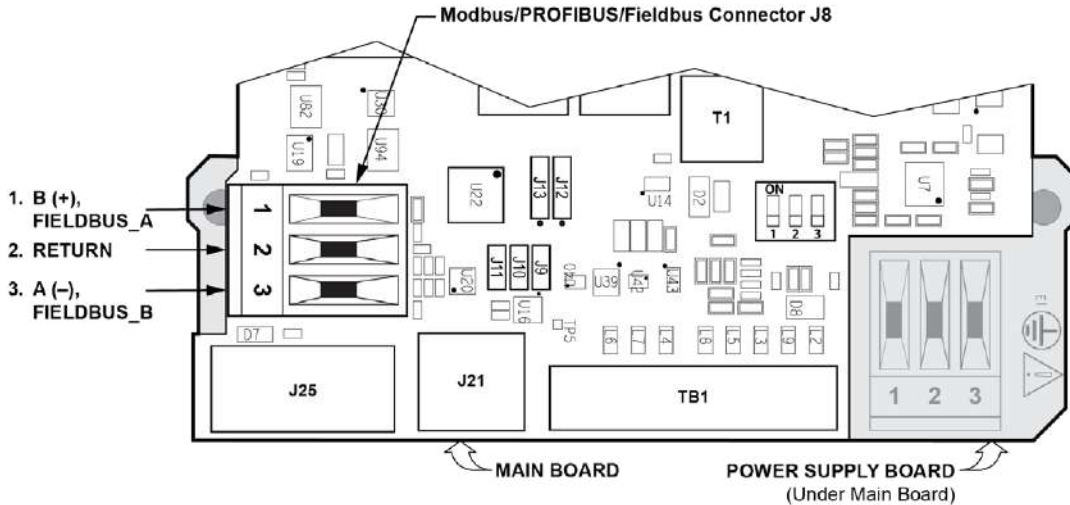

C01460-1-1

**Figure 24 – Modbus/PROFIBUS/Fieldbus Connections, J8**

Connect the ST80/ST80L to a Modbus device/network using a 2-wire RS-485 connection scheme as shown in [Figure 25](#) below. For details on Modbus operation refer to [Modbus Operation](#), page 70.

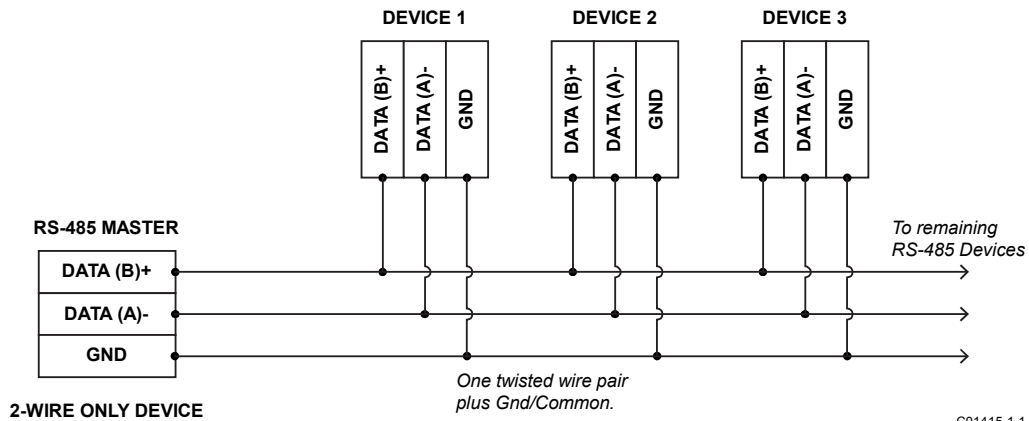

C01415-1-1

**Figure 25 – Modbus Wiring**

*Modbus Configuration*

Refer to [Figure 18](#) on page 22. To set **J8** for Modbus operation install a 2 mm jumper shunt onto the J12 and J13 jumper pins as shown in [Table 3](#) below.

**Table 3 – Modbus Select Jumpers**

	<b>J12</b>	<b>J13</b>
Install Jumper Shunt over Pins →	1 and 2	1 and 2

As required for your application set 2 mm jumper shunts as needed to configure the bus lines as listed in [Table 4](#) below. Termination is typically required for applications with faster data rates or long cable lengths or both. Enable the instrument’s terminator as required for your application. Line biasing is used to ensure that lines are at a known state (noise can cause a false trigger on a floating line). Check first that the RS-485 network is not already biased before enabling the ST80/ST80L line biasing.

**Table 4 – Modbus Line Configuration Jumpers**

	<b>J9</b>	<b>J10</b>	<b>J11</b>
<b>Line Biasing (pullup)</b>	●	—	—
<b>150 Ω Termination</b>	—	●	—
<b>Line Biasing (pulldown)</b>	—	—	●

Note: 1. ● = Jumper Installed

**FOUNDATION Fieldbus/PROFIBUS Connections (Option)**

Referencing [Figure 16](#) connect the FOUNDATION Fieldbus/PROFIBUS device/network to Phoenix connector **J8** on the main board. Note that the **J8** connector is also used for the Modbus wiring (only one interface can be active at a time). See [Figure 24](#) above. Connector **J8** accepts 24–12 AWG (0.2 mm<sup>2</sup> – 1.5 mm<sup>2</sup>) wire (refer to [Table 2](#), page 20 for wire size vs. length info). It is recommended that wiring have a flammability rating of UL 2556 VW-1 or equivalent.

Connect the ST80/ST80L to a Fieldbus/PROFIBUS device/network as shown in [Figure 26](#) below. Note that devices are connected in parallel (star fashion). Use a terminator as appropriate for your application. For details on PROFIBUS operation refer to the ST80/ST80L PROFIBUS PA manual **06EN003493**. For details on FOUNDATION Fieldbus operation refer to the ST80/ST80L FOUNDATION Fieldbus manual **06EN003492**.

**Note:** Foundation Fieldbus/PROFIBUS operation is provided through an optional add-on card that plugs into the ST80/ST80L main board.

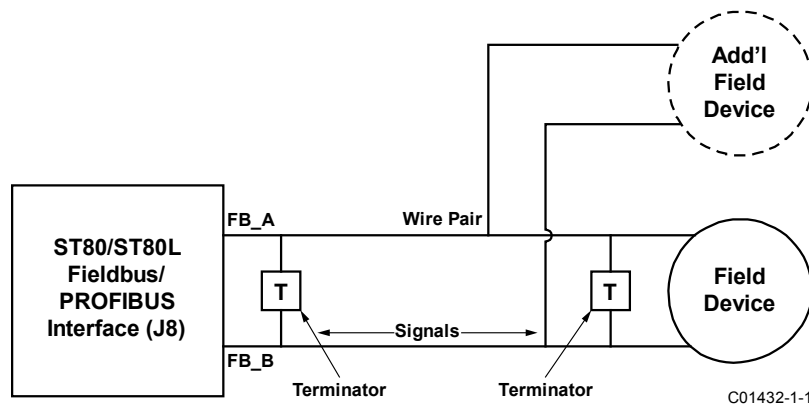

**Figure 26 – Fieldbus/PROFIBUS Wiring**

*FOUNDATION Fieldbus/PROFIBUS Configuration*

Refer to [Figure 18](#) on page 22. To set **J8** for FF/PROFIBUS operation install a 2 mm jumper shunt onto the J12 and J13 jumper pins as shown in [Table 5](#) below.

**Table 5 – FOUNDATION Fieldbus/PROFIBUS Select Jumpers**

	J12	J13
Install Jumper Shunt over Pins →	2 and 3	2 and 3

As required for your application set 2 mm jumper shunts as needed to configure the bus lines as listed in [Table 6](#) below. Termination is typically required for applications with faster data rates or long cable lengths or both. Enable the instrument's terminator as required for your application. Line biasing is used to ensure that lines are at a known state (noise can cause a false trigger on a floating line). Check first that the RS-485 network is not already biased before enabling the ST80/ST80L line biasing.

**Table 6 – FOUNDATION Fieldbus/PROFIBUS Line Configuration Jumpers**

	J9	J10	J11
Line Biasing (pullup)	●	—	—
150 Ω Termination	—	●	—
Line Biasing (pulldown)	—	—	●

Note: 1. ● = Jumper Installed

*FOUNDATION Fieldbus/PROFIBUS Add-On Card Diagnostics/Test*

As shown in [Figure 18](#) on page 22 a mini-DIP switch (use push pin or ballpoint pen to actuate) controls the optional Fieldbus/PROFIBUS add-on card's #SIM\_ENABLE, #NV\_ERASE, and #HW\_LOCK test signals. This provides a means to activate a "simulate mode" for Fieldbus conformance testing and for add-on card testing/diagnostics. A particular signal is active when its switch is set to ON. For normal use all switches are OFF.

**Service Port Connection, USB**

The ST80/ST80L is provided with a USB service port that is used to configure/monitor the instrument via a PC. Refer to [Configuring the ST80/ST80L](#), page 31 for further information on service port use.

- **USB 2.0** – USB Type B connector J21 on the main board (for local connection of PC to the instrument)

**Post Installation Check**

Verify all wiring connections are secure and correct to the appropriate wiring diagram. Verify the flow direction arrow on the flow element is pointing in the right direction. Verify the mechanical process connection is secure and meets the system pressure requirements.

This Page Intentionally Left Blank

### 3 OPERATION

#### Basic Commissioning and Start-Up

Verify the wiring and then apply power to the instrument. LCD-equipped instruments briefly show a welcome screen indicating the instrument model and core version followed by the normal operation process screen. The normal process screen shows: percentage of flow bar, icons (if present), process flow rate, totalized flow (optional), temperature in customer units, pressure (optional) in customer units, calibration group and group name. Once set up there is little need for interaction between the operator and flow meter. Configure the instrument as necessary using either the HMI interface (option) or the ST80/ST80L configuration software application.

#### Configuring the ST80/ST80L

There are two ways to configure the ST80/ST80L:

- **HMI Front Panel Menu** – For instruments with the optional HMI display, access the instrument's service menu as described in [HMI Option, Basics](#) below.
- **ST80/ST80L Configuration Software application** – The ST80/ST80L comes with Windows software (PC only) that provides comprehensive programming of the instrument's settings. Refer to [ST80/ST80L Configuration Software](#), page 35.

#### **HMI Option, Basics**

The HMI (Human-Machine Interface) option provides the ST80/ST80L with a built-in setup tool. Four IR (infrared) sensor buttons located at the 3, 6, 9, and 12 o'clock positions on the display provide access to basic setup parameters. The HMI Service menu can be accessed through the window without removing the electronics enclosure lids. Enter the HMI service mode by touching the glass in front of the 12 o'clock sensor (Hot Key) for 3 seconds. The LCD acknowledges the button selection by flashing then inverting the display characters and background while the button is held.

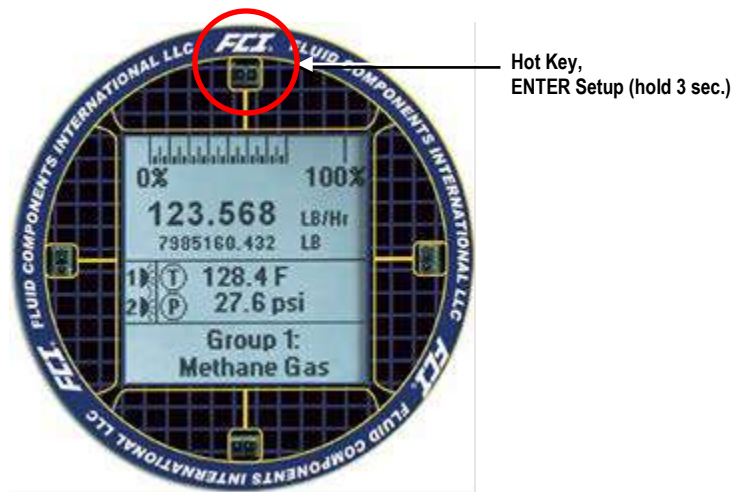

Figure 27 – Hot Key on the Optional HMI Display

### HMI Display Menu Navigation

Use the four IR sensors to navigate the HMI Service menu. Touch the top/bottom sensor to scroll up (↑)/down (↓) through the menu selections. Touch the right sensor to select (✓). Touch the left sensor to go back (↶) to the previous menu.

Some setup parameters are password protected—when prompted enter the **HMI user password: E#C**. Use the Up/Down scroll key to select a character. After scrolling to the desired character, touch the Select (✓) key to go to the next character. After entering the password the display returns to the menu item. Select the item again by touching the Select key.

Immediately exit HMI service mode and return to the process display by touching the bottom (↓) sensor for 2 seconds. Backing out of menus via repeated touches of the left button also exits the service mode. Refer to [HMI Menu Outline](#), page 131 for an overall view of the menu structure. Note that the front panel menu provides only a small subset of the instrument's settings. This makes the front panel menu an ideal tool for quick adjustments.

**Notes:** The optional HMI interface provides for quick adjustments using only a subset of instrument programming commands. Use the ST80/ST80L configuration software application for in-depth programming.

A menu item with an asterisk (\*) is inaccessible due to an active connection to a PC running the configurator software (only one master can be active at a time), or an extended mode is in effect which restricts group selection.

To accommodate various instrument mounting situations the LCD can be electronically rotated for easy viewing. Refer to [Display Options](#), page 34 for details.

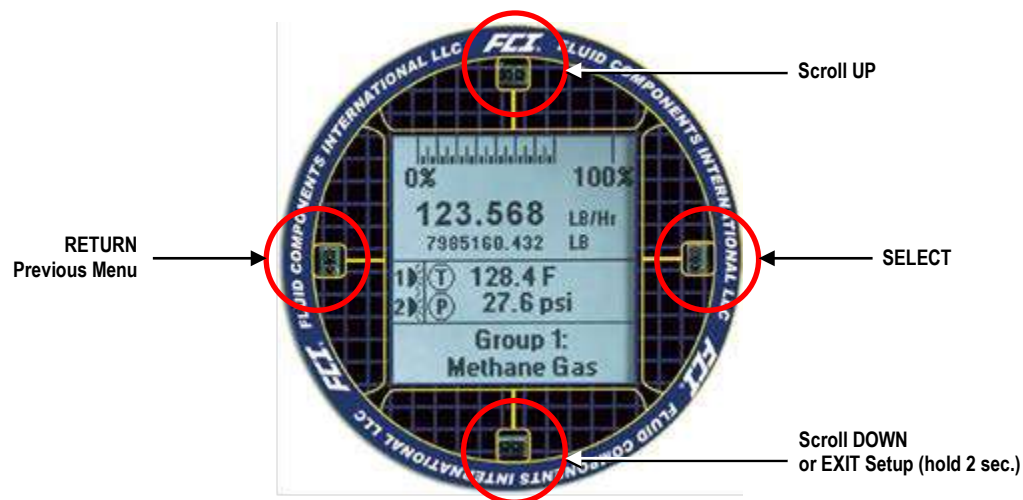

Figure 28 – HMI Display IR Sensor Functions



Basic Setup Options, HMI

Figure 29 below summarizes the basic setup options using the optional HMI. Enter the HMI user password as required when changing a setup parameter.

**Note:** The setup options described in this section (except *Language*) can also be changed via the configuration software. Refer to [Basic Setup Options, Configuration Software](#) on page 35.

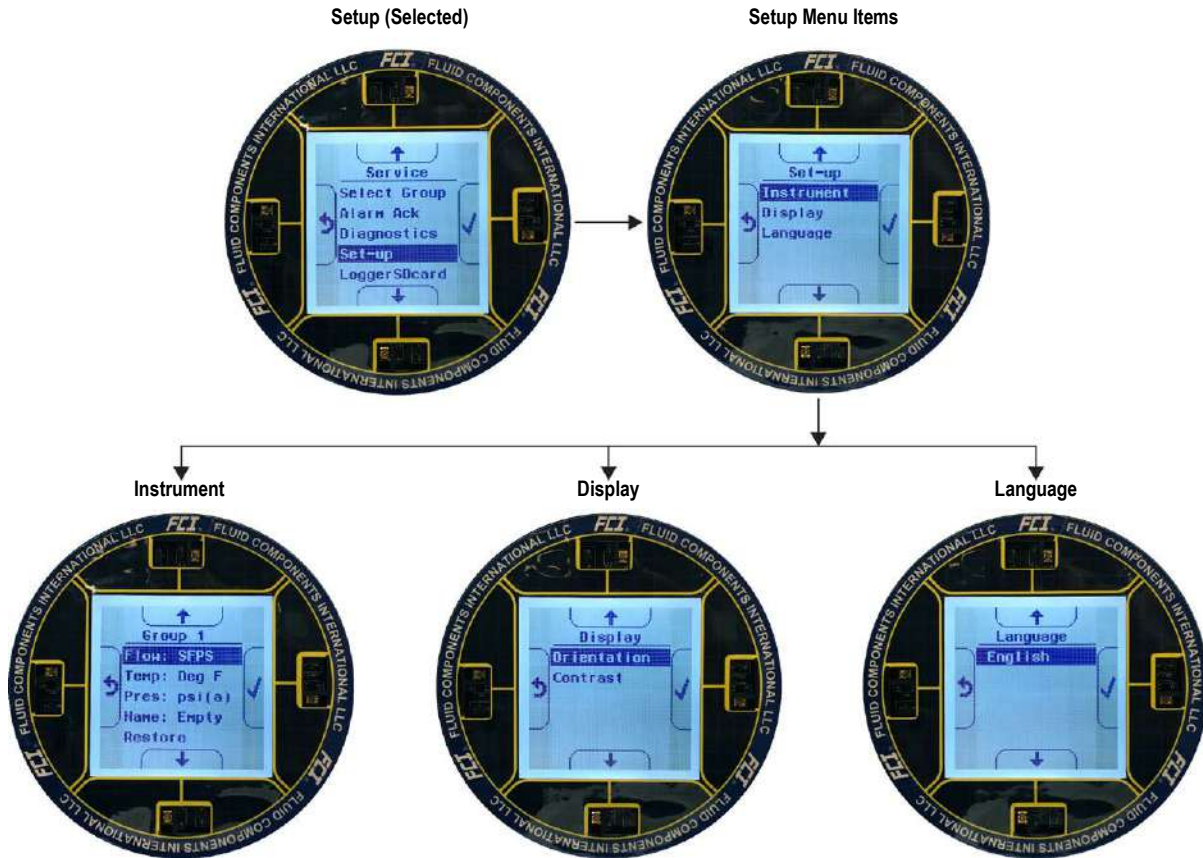

Figure 29 – Basic Setup Options, HMI

INSTRUMENT OPTIONS

Figure 30 below summarizes the Instrument options pertaining to the currently selected group (of which there are five). Enter the HMI user password **E#C** as required when changing a setup parameter.

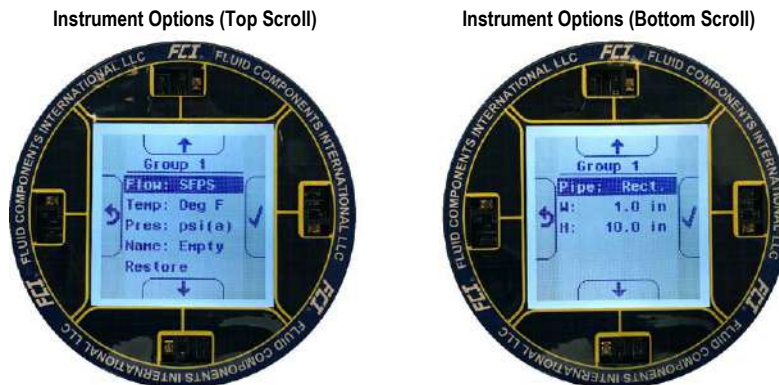

Figure 30 – Instrument Setup Options

Instrument setup includes the following parameters:

- **Flow** – Sets flow parameters including flow type and flow timebase. [Table 7](#) below summarizes the *Flow* parameters. The default is **Vel Flow, SFPS** (Standard Feet Per Second).
- **Temperature (Temp)** – Sets the temperature scale in use: *Degrees C* (Celsius) or *Degrees F* (Fahrenheit). The default is **Degrees F**.
- **Pressure (Pres)** – This normally sets the pressure units in use. Since ST80/ST80L cannot read pressure this value is not applicable and is fixed at **psi(a)**.
- **Name** – This sets a descriptive name for the displayed process flow. Use a name as required for your application. The default is **Empty**.
- **Restore** – Select this item to restore the instrument setup parameters to the factory defaults.
- **Pipe** – This sets the pipe geometry. Choose between *Round* and *Rectangular*. When set to *Round* the diameter (D) dimension is shown – set the diameter of the round pipe in inches (default is 1.0"). When set to *Rectangular* the width (W) and height (H) dimensions are shown – set the width and height of the rectangular pipe in inches. The default is **Rectangular, W: 1.0", H: 10.0"**.

**Table 7 – Flow Parameters, HMI**

Flow Type		Flow Timebase	
<b>Velocity</b>	<b>Vel Flow</b>	<b>Std Feet</b>	<b>Per Second</b> Per Minute Per Hour Per Day
		Nml Meters	
<b>Volumetric</b>	Vol Flow	Std Cu Feet	
		Nml Cu Meters	
		Nml Liters	
<b>Mass</b>	Mass Flow	Pounds	
		Kilograms	
		Metric Tonnes	

Note: **Bold** type indicates factory default setting.

DISPLAY OPTIONS

[Figure 31](#) below summarizes the display setup options.

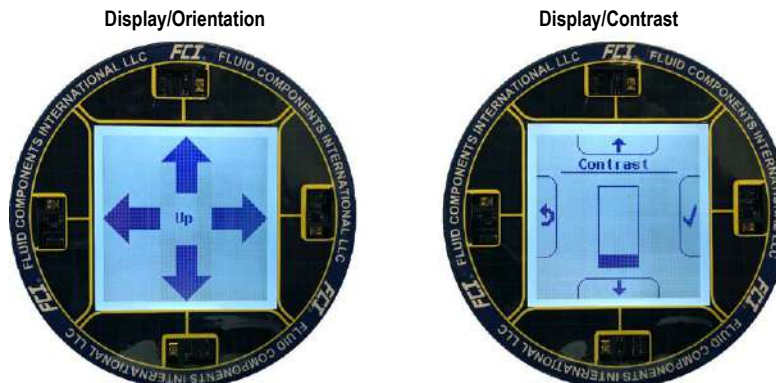

**Figure 31 – Display Setup Options**

Display setup includes the following parameters:

- **Orientation** – Use this parameter to change the LCD orientation for easier viewing. Selecting *Orientation* changes the display to arrows pointing to the four sides of the LCD. Press the corresponding IR sensor to assign that side as the LCD top.
- **Contrast** – Use this parameter to adjust the display contrast via the Scroll Up/Scroll Down buttons. Contrast decreases with upward movement of the bar graph.

LANGUAGE OPTION

There is currently only one language option: **English** (default/fixe).

### ST80/ST80L Configuration Software

The ST80/ST80L comes with a configurator utility (Windows) that provides comprehensive programming of the instrument's settings via a PC connection to the instrument's USB service port (refer to [Service Port Connection, USB](#), page 29). Configure the ST80/ST80L to your application using the ST80/ST80L configuration software. Refer to the ST80/ST80L Configuration Software manual **06EN003491** for full instructions on the use of the application. Refer also to [ST80/ST80L Configuration Software Application \(User Password: 2772\)](#) below for further details.

**Note:** Make sure the ST80/ST80L is up and running **before** connecting to USB or launching the configurator application.

#### Basic Setup Options, Configuration Software

The setup parameters accessed by the optional HMI are also accessible via the configuration software's **Basic Setup** menu. See [Figure 32](#) below. For units without an HMI display use the configuration software to perform basic instrument setup. The **Basic Setup** menu tabs to use are: *Groups*, *Units*, *Pipe Size*, and *Display Settings*. If needed, use the *Alarms* and *Totalizer* tabs to complete the instrument configuration. Refer to [Basic Setup Options, HMI](#) on page 33 for an overview of the setup parameters. Refer also to the ST80/ST80L Configuration Software manual **06EN003491** for detailed information about the software.

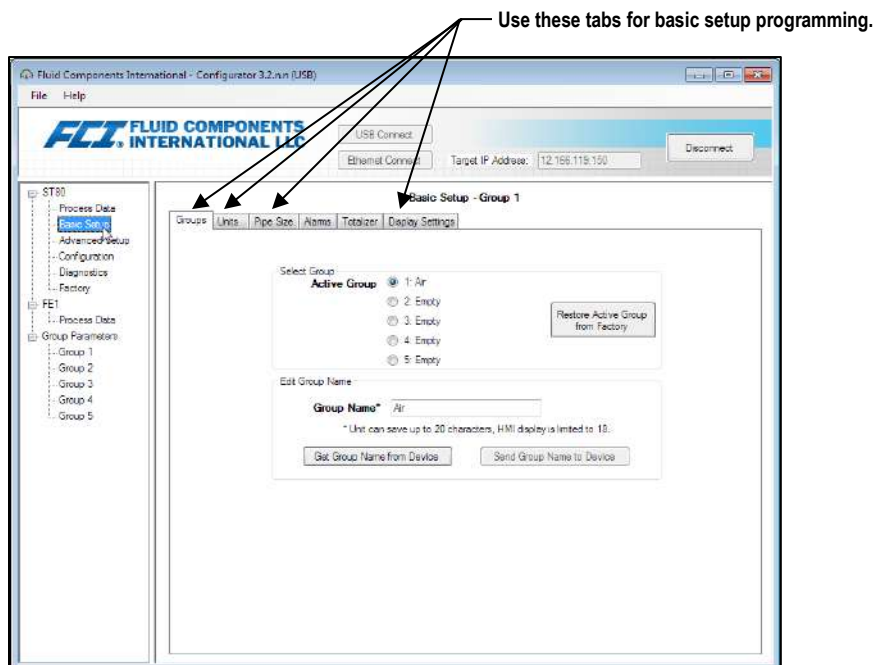

Figure 32 – Configuration Software Tabs for Basic Setup Functions

### Verify Engineering Units

Verify that the engineering units are correct for flow rate and temperature. Use the HMI menu or configuration software to make any necessary changes.

### System Faults, Alarms and Logging Indication

The ST80/ST80L optional display shows system faults, alarms, and data logging activity by displaying three different icons when these conditions are present. As shown in [Figure 33](#) below, these icons appear directly above the flow rate indication on the main process data screen. FAULTS are displayed as a caution triangle icon, ALARMS as a bell icon, and LOGGING as a paper sheet icon (logging feature not applicable to ST80/ST80L).

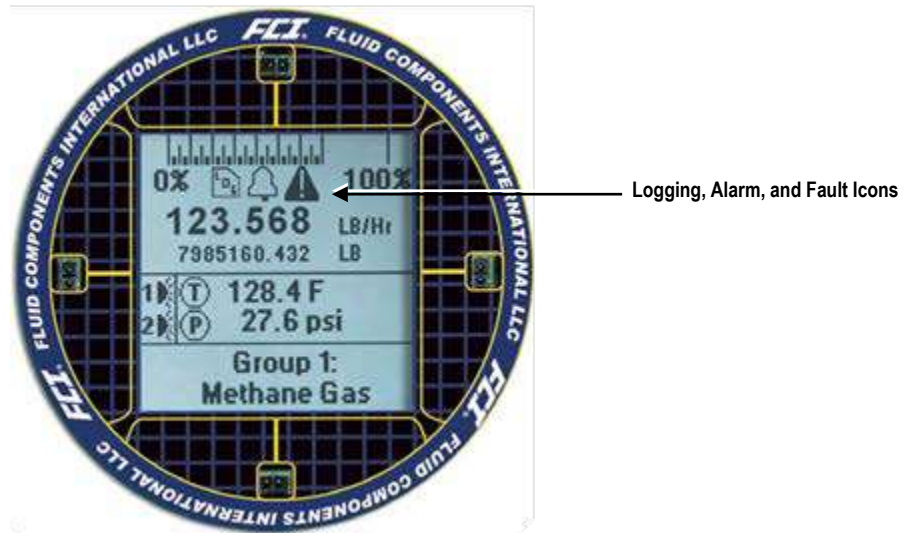

Figure 33 – Example Log, Alarm, and Logging Icons on the Optional Display

**ST80/ST80L Configuration Software Application (User Password: 2772)**

The ST80/ST80L configuration software application provides full access to instrument programming. However, this requires opening the electronics enclosure and attaching a PC to the instrument’s USB service port. The ST80/ST80L configuration software application is intuitive, easy to use and the preferred method for commissioning the instrument.

Use a passive, straight-through USB 2.0 cable with a type-A male connector on one end and a type-B square plug on the other end (as supplied with the instrument). Connect the USB cable’s type-A connector to the computer’s USB port. Connect the other end of the cable to the instrument’s USB receptacle (remove blind lid to access the USB service port). With instrument power ON, launch the application by double clicking the configuration software’s icon on the PC’s Windows desktop:  An example of the configurator Welcome screen is shown below.



Figure 34 – The Configurator Welcome Screen

A local USB connection to the PC is the primary communication method—click **USB Connect** to activate this connection, which results in the display of the Process Data screen as shown in the example in [Figure 35](#) below.

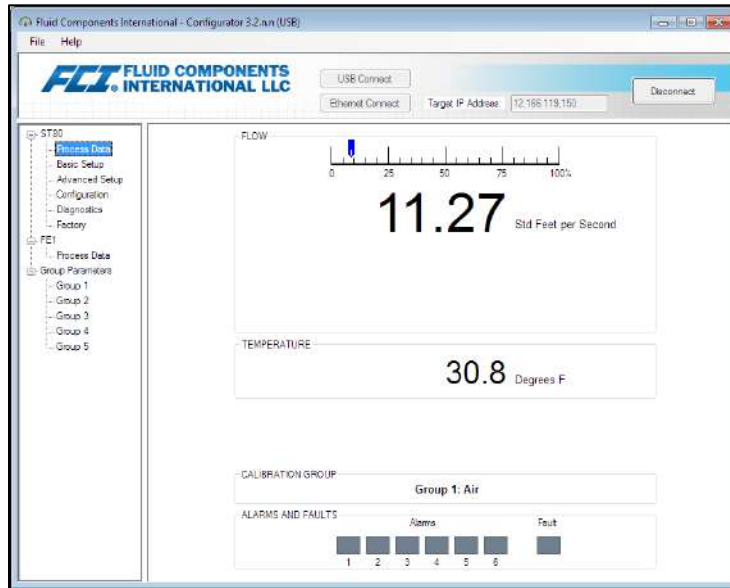

Figure 35 – Example Process Data Screen

With the configuration software running on the attached PC the user has access to all configurable features of the ST80/ST80L instrument. When prompted, enter the User Level Password (2772) to make parameter changes. For more detailed instructions on the configuration software, refer to the ST80/ST80L Configuration Software manual **06EN003491**.

**Note:** An asterisk (\*) shown next to a menu item on the optional display means that the item is “locked out” due to the flow meter communicating with the configurator. Note also that the HMI presents only a subset of configurable settings.

**Real Time Clock**

The ST80/ST80L system time is maintained by a battery-powered real time clock that is set to Pacific time at the factory. Synchronize the flow meter’s system time to the installed location’s local time using the configuration software (the date/time cannot be programmed via the HMI).

Start the ST80/ST80L configuration software application. Click **USB Connect** on the welcome screen. Select the *Advanced Setup* branch from the menu tree on the window’s left side. Select the **Date and Time** tab. See Figure 36 below.

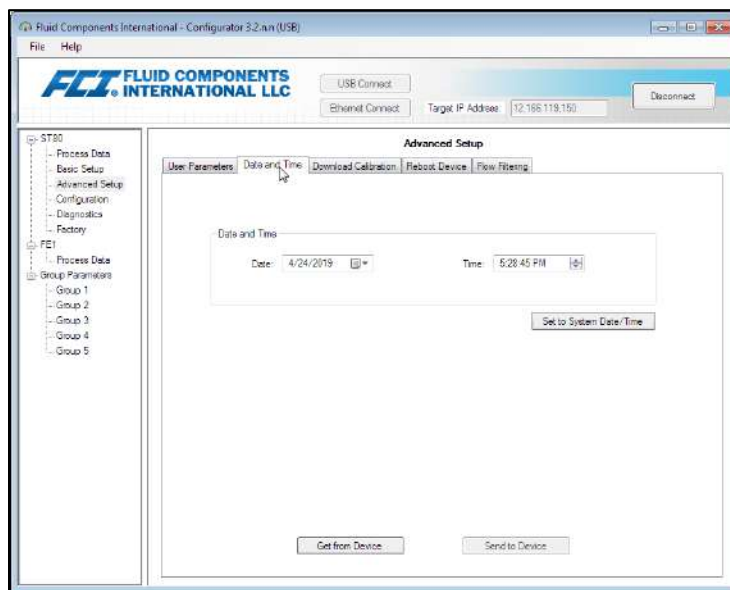
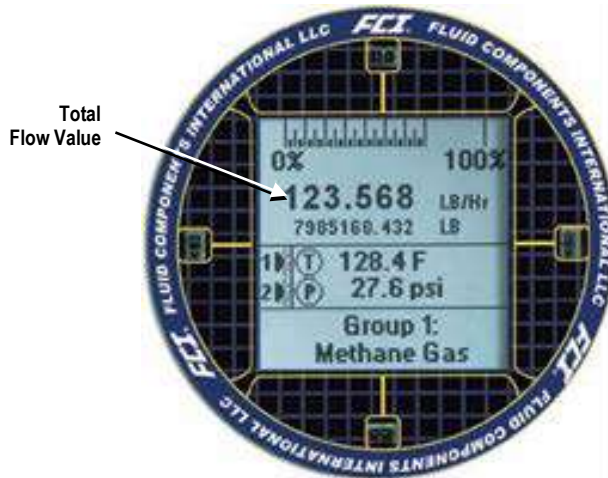

Figure 36 – Example Date and Time Set Screen

Click **Get from Device**. This displays the current date and the ST80/ST80L system time. If needed, set the correct date using the field's calendar date picker and time using the field's spinner buttons. Click **Send to Device** to save the changes to the instrument.

**Totalizer Setup**

The flow totalizer function accumulates the instrument total flow, much like the odometer on an automobile. The engineering flow units must be set in mass or volumetric units for the function to work. The totaled flow value is displayed directly below the indicated flow rate on the instrument display. The totalizer is enabled and displayed by default. Use the ST80/ST80L configuration software to set up the totalizer (the totalizer cannot be programmed via the HMI).



**Figure 37 – Example Totalizer Display Showing Total Flow Value**

Start the ST80/ST80L configuration software application. Click **USB Connect** on the home screen. Select the *Basic Setup* branch from the menu tree on the window's left side. Select the **Totalizer** tab. Configure as desired (check/uncheck the check boxes). Click **Send to Device** to save the changes to the instrument (enter the user level password 2772 when prompted). Click **Get from Device** to verify any changes.

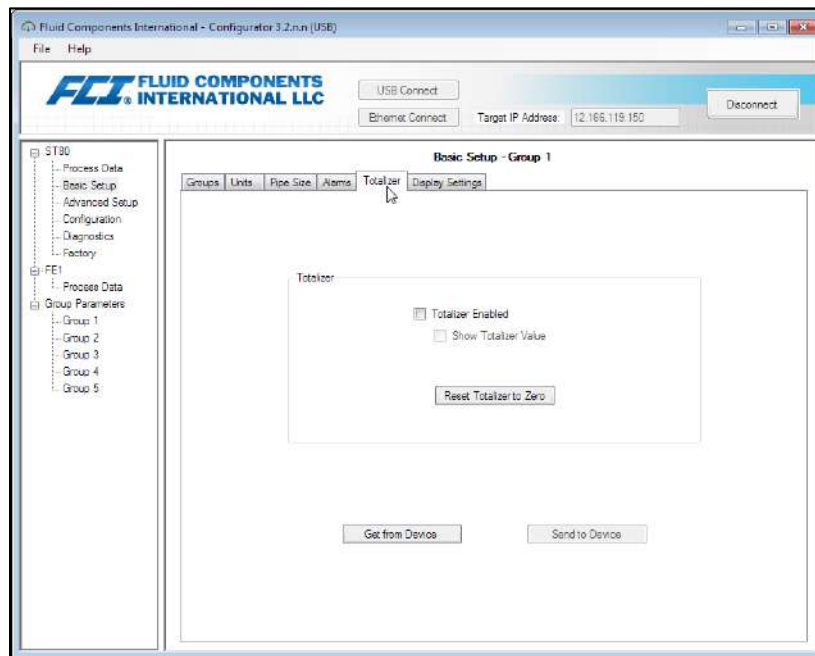

**Figure 38 – Totalizer Setup Screen**

## Configuring for AST™ or Constant Power Measurement Methods

The default factory sensor heater configuration is AST™ (Adaptive Sensing Technology) in which the instrument automatically transitions between constant Delta T operation (heater power to maintain Delta T proportional to flow) and constant power operation (constant heater power and sensor Delta T proportional to flow) to measure the flow rate. Refer to [Theory of Operation](#), page 1. The alternate heater mode choice is *Constant Power* mode (only).

**Caution:** Only in certain cases should the instrument be configured from AST™ to Constant Power. Consult the factory for guidance to determine if the Constant Power mode is optimum for your process conditions.

Use the configuration software to set the heater mode to **AST** or **Constant Power** as follows (refer to the ST80/ST80L Configuration Software manual **06EN003491** for software details):

1. Access the **AST Power Mode** tab from the **Configuration** branch of the menu tree. See [Figure 39](#) below.
2. In the *AST Heater Power Mode* field, pull down the *Power Setting* menu and select **Constant Power** or **AST** (default).
3. If **AST** is selected, pull down the *Max. Current* menu and select the maximum current at which the unit transitions to Constant Power: **105 mA** or **90 mA** (default).

**Note:** The VC and VD data fields are DAC values used in the heater modes. This data is for factory use only.

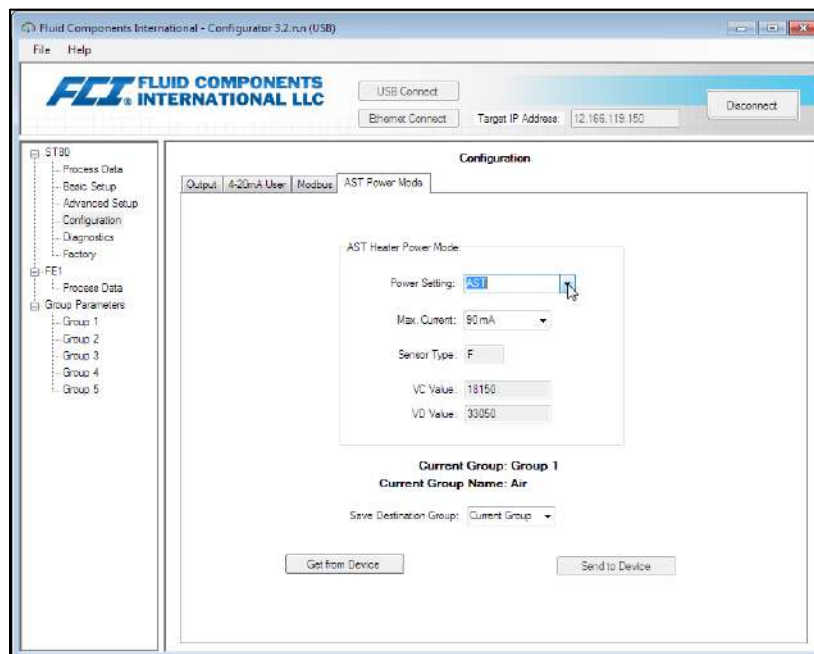
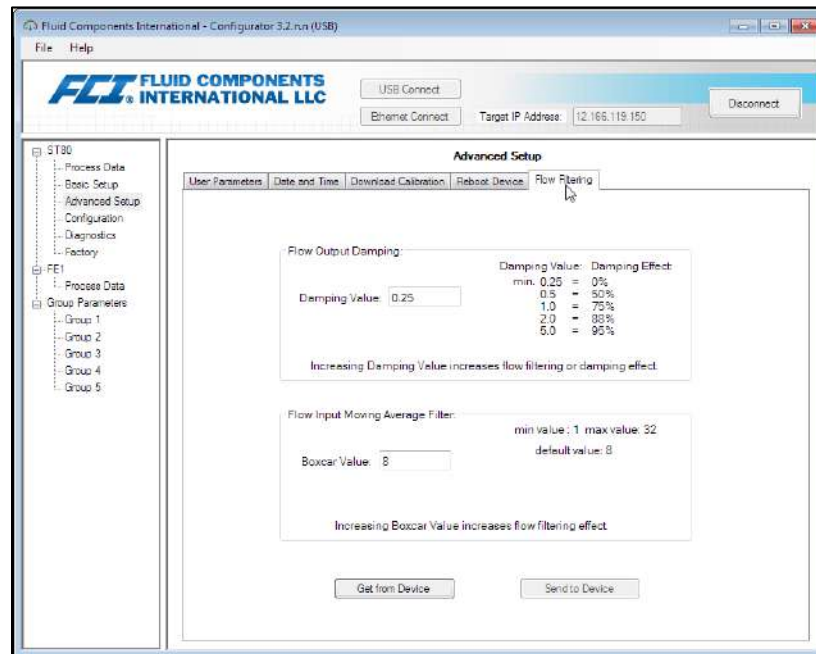

Figure 39 – Example AST Power Mode Tab (Configuration)

## Flow Filtering

Use the configuration software to adjust flow filtering (*Advanced Setup/Flow Filtering*) as required for your application. Refer to the ST80/ST80L Configuration Software manual **06EN003491** for software details. The **Flow Filtering** setup screen is shown in [Figure 40](#) below. Two types of flow filtering are available: *Flow Output Damping* and *Flow Input Moving Average Filter*.



**Figure 40 – Flow Filtering Setup Screen**

### Flow Output Damping

Use the *Flow Output Damping* field to smooth out the flow signal output for applications in which process conditions are erratic or for applications using the more sensitive AST (Adaptive Sensing Technology) configuration.

As shown in [Figure 41](#) below, an increase in flow damping value results in an output that is increasingly resistant to change (amplitude variations). Compare the chart's blue curve (value = 0.25 for 0% flow damping) with the chart's black curve (value = 5.00 for 95% flow damping). The black curve shows signal excursions that are much more constrained relative to the blue curve.

The minimum value that can be entered is 0.25 (0% flow damping). It is possible to enter a number greater than 5.0 (95% flow damping). The practical limit, however, is 5.0 since 100% flow damping will never be attained regardless of the entered value.

**Caution:** High flow damping values result in reduced flow response. Make sure that alarm conditions are not affected when using the flow damping feature.



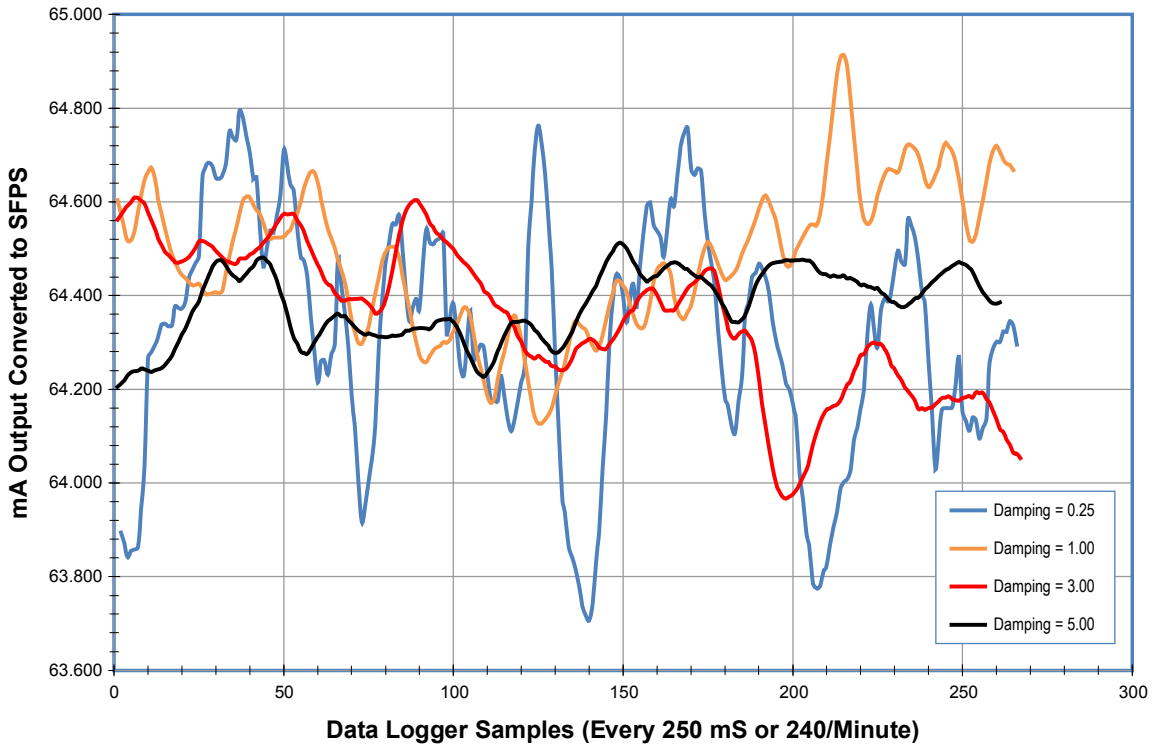

C01406-1-1

**Figure 41 – Chart: Flow Output Over Time with Various Flow Damping Values**

**Flow Input Moving Average (Boxcar) Filter**

Use the *Flow Input Moving Average Filter* field to smooth out the input flow signal using a moving average (boxcar) filter. The boxcar filter averages the last *X* number of readings. A larger boxcar value does a better job of averaging at the expense of a slower response time. The factory default boxcar value is **8** (readings). With readings occurring at 5 times a second, the factory boxcar setting is an average of the last 1.6 seconds.

**Caution:** High boxcar values result in reduced flow response time. Make sure that alarm conditions are not affected when using the moving average filter.

**NAMUR Setup**

NAMUR NE43 is a German fault detection standard that lets the user know if there is a fault within the instrument by forcing the 4-20 mA output current outside the normal operating range of the instrument.

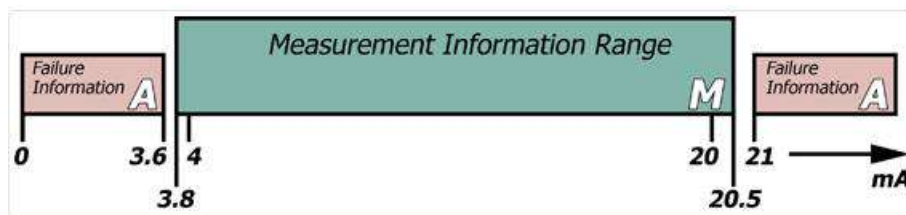

**Figure 42 – NAMUR Fault**

Use the ST80/ST80L configuration software to enable/configure the NAMUR feature. The optional front panel HMI interface cannot access NAMUR.

Click **USB Connect** on the home screen. Select the *Configuration* branch from the menu tree on the window's left side. Select the **4-20mA User** tab. Tick the desired channel's **NAMUR Enabled** checkbox.

**Note:** The NAMUR settings field in the 4-20 mA User tab will only show when the output is set for Flow or HART Flow. If Temperature output is selected the NAMUR settings will not show up. NAMUR only works on Flow outputs.

In the window's NAMUR field, define the NAMUR output level by clicking either **Set NAMUR @ 3.6 mA** or **Set NAMUR @ 21.0 mA**. Click **Send to Device** to save the settings to the instrument. To discard changes just exit the screen (do not click **Send to Device**).

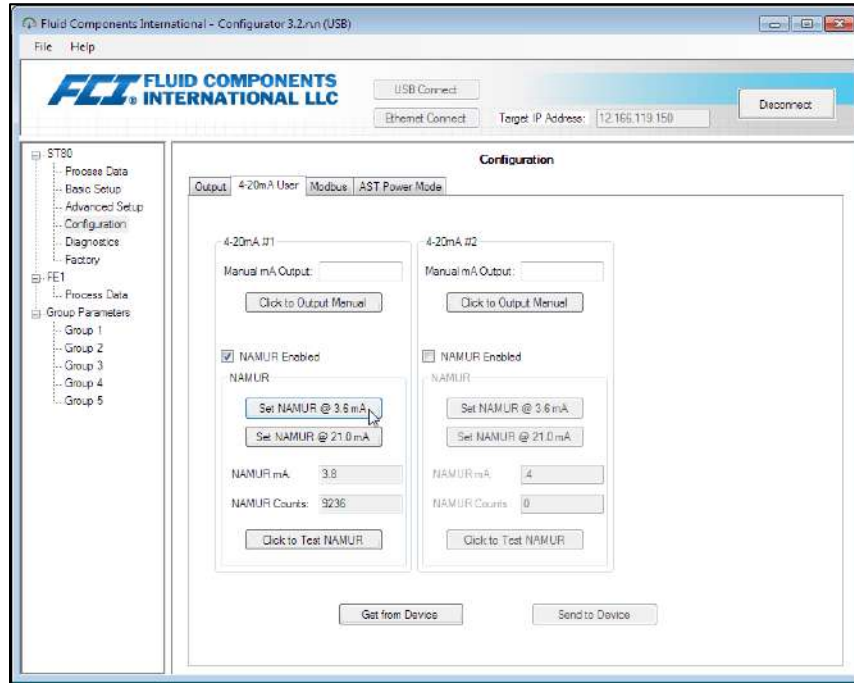

**Figure 43 – NAMUR Output Level Selection (4-20 mA User Tab)**

When NAMUR is enabled, and a fatal fault is detected, the 4-20 mA output is forced to the preselected NAMUR output level. Use the **Click to Test NAMUR** button (forces NAMUR output) as needed to verify the system setup and wiring.

**Table 8 – Fatal Faults that Trigger NAMUR**

Fault Bit	Fatal Fault Error or Status Description
1	CORE: any of these errors: I2C error, UART error, Mutex error, or Watchdog Reset.
4	CORE: unable to update process data (PD_NO_FE_DATA). Unable to get/use data from any active FEs.
6	CORE: detects FRAM/SPI error.
11	(Any) FE Board Temperature Out of Limits
14	CORE: unable to communicate with one or more FEs (PD_COMM_ERROR).
20	CORE: averaged temperature above "Temperature Max."
21	CORE: averaged temperature above "Temperature Min."
22	(Any) FE reports SENSOR_HEATER_SHORTED_FAULT.
24	(Any) FE reports SENSOR_HEATER_OPEN_FAULT.
27	(Any) FE reports SENSOR_ADC_BELOW_MIN_FAULT.
30	(Any) FE reports SENSOR_ABOVE_MAX_TEMPERATURE_FAULT.
31	(Any) FE reports SENSOR_UNDER_MIN_TEMPERATURE_FAULT.

### Internal Delta-R Resistor (idR) Check

The Internal Delta-R Resistor (idR) Check is a routine designed to assess the ST80/ST80L internal normalization. The normalization process fine tunes the instrument's ability to accurately measure resistance. Proper normalization also allows FCI electronics to be interchangeable for replacements, spares or repaired boards. If the unit's normalization shifts, the accuracy of the meter may be compromised.

By passing the same sensor excitation current used to power the RTDs across three high precision idR resistors (60  $\Omega$ , 100  $\Omega$ , and 150  $\Omega$ ) trending patterns can be established. Periodically run the idR check to verify proper operation of the ST80/ST80L electronics. Use the idR check as a troubleshooting tool to isolate a fault between the sensor and the electronics.

#### Running the idR Check Using the Optional HMI

Hold the "Hot Key" (top sensor) for three seconds. Select **Diagnostics** and then **Self Test**. Select **FE 1 IDR** and enter the User Level Password (**E#C**). After successful password entry the display shows the **FE 1 IDR** list again. Select (again) the desired FE. Observe that **Test in Progress** displays along with a timer counting down the seconds. See [Figure 47](#), page 45 for the idR test display sequence.

When the idR check completes the expected and measured values for each idR resistor are shown on the HMI display as shown in the example in [Figure 44](#) below. The left part of the screen shows the expected (**EXP'D**) values. The right part of the screen shows the measured (**MEAS'D**) values. If all three checks pass ("**P**" shown at the right of all lines), **PASSED** displays at the bottom. Should any one of the three checks fail ("**F**" shown at rightmost part of a line), **FAILED** displays at the bottom. Data from an HMI-initiated idR check is not saved; therefore, record the data by hand as required.

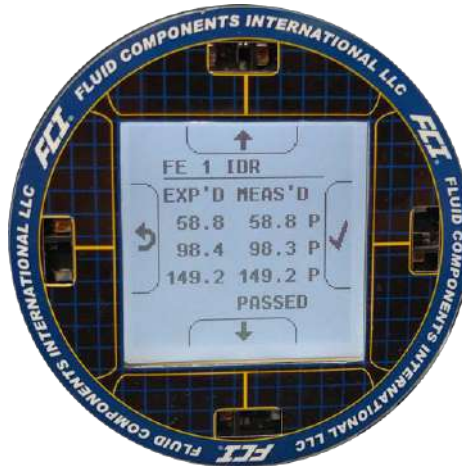



Figure 44 – Example idR Check Results Display

#### Running the idR Check Using the ST80/ST80L Configuration Software

Click **USB Connect** on the home screen. Select the *Diagnostics* branch from the menu tree on the window's left side. Select the **idR Scheduled Tests** tab. See [Figure 45](#) below. Select the "FE #" desired from the **Selected FE** drop-down list (only FE1 shows for ST80/ST80L). Two settings that affect scheduled and on-demand idR tests are provided on this screen: *FEx Internal Delta-R Pass Fail Criteria*, **Maximum Allowed Error** (default = 0.5 ohms) and *FE1 Output Mode During Test*, **Mode** (default = Freeze Flow During Test). Make changes to the default settings as required for your application.

In the *FE1 Schedule Internal Resistor Check* field, use the **Mode** drop-down list to select a schedule mode: Disabled (default), Day of Month (1-28), Day of Week (0=Sun), or Every(Day). Use the **Day, #days, DOW** spinner control to define the selected schedule mode. Use the **Time** spinner control to enter the desired scheduled check start time. Alternatively, click **Run test now on FE1** to run the idR check on demand (enter User level code 2772).

**Note:** When an idR check is started from the configuration software (scheduled or on-demand) the displays shows the Fault icon () above the flow rate as the check runs. The Fault icon disappears when the idR check completes.

After clicking **Run test now on FE1** the *FE1 idR Test Results* field displays the expected and the measured resistance values. These instant checks are not logged to onboard memory (FRAM) and not displayed under the **idR Test Logs** tab as the Scheduled Tests files.

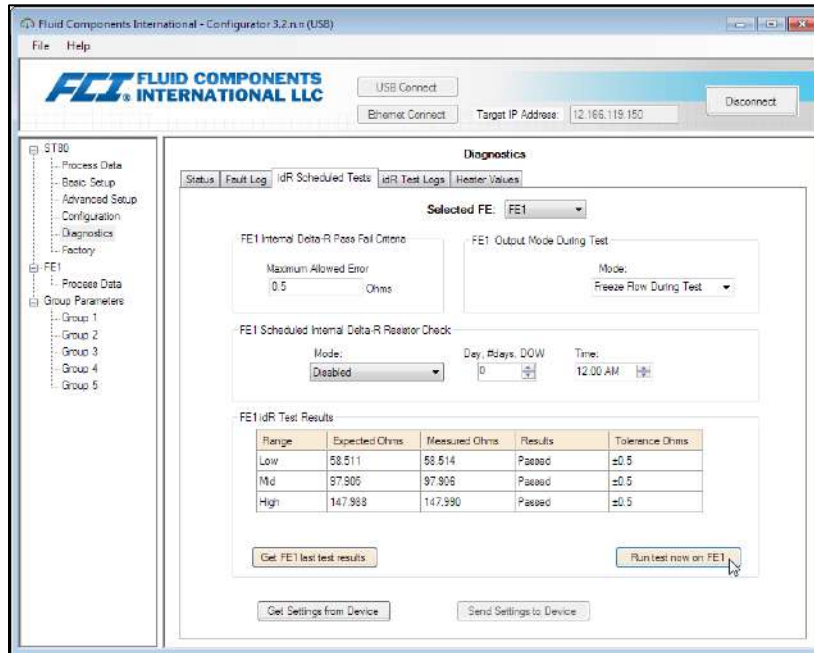

Figure 45 – Example Internal Delta R Scheduled Screen (After Clicking "Run test now...")

The result for a scheduled idR check is logged in FRAM. Click **Get Test Log from Device** in the idR Test Logs tab to view the idR test log as shown in the example in Figure 46 below.

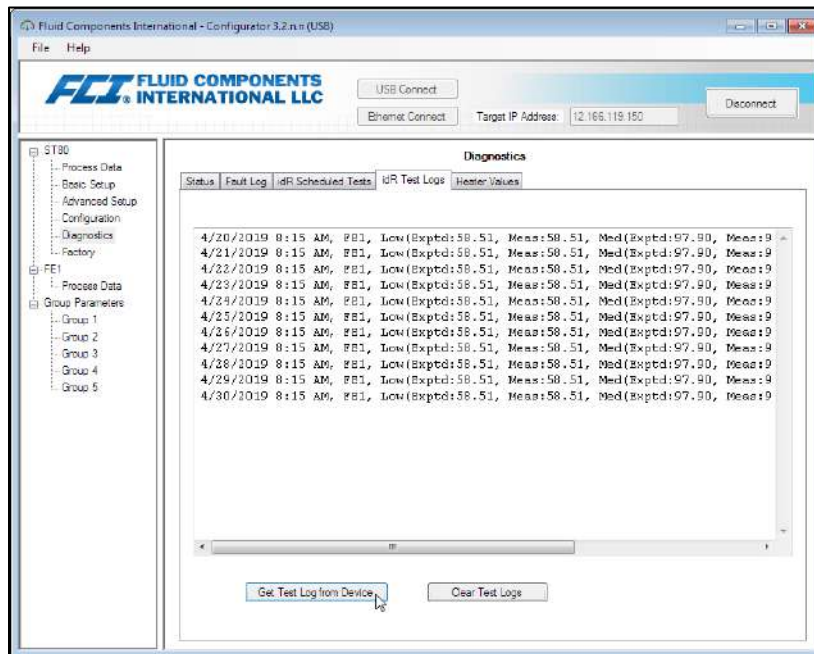

Figure 46 – Example Internal Delta R Test Logs Screen

HOT KEY



1. Normal Operation Display:  
Select and hold the hot key for 3 seconds.



2. Select Diagnostics.



3. Select Self Test.



4. Select FE1 IDR (FE 2 applicable to ST100A Series only).



5. Input Password E#C.



6. Select (Enter) Password.

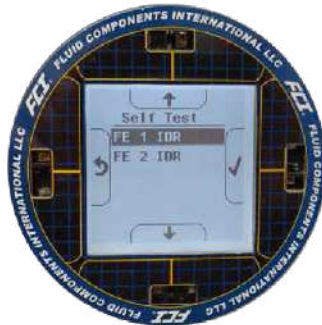

7. Select FE1 IDR again.



8. Observe idR test in progress (seconds countdown).



9. idR Test is Complete. Record values for comparison.

C01421-1-1

Figure 47 – Internal Delta-R Resistor Check (idR) HMI Display Sequence

### Analog Output Response to idR Check

During the idR sequence the analog outputs respond as listed below. Readings are taken with a 250  $\Omega$  load across Analog Output 1, 2 or 3.

#### NAMUR Enabled LOW

2.325 Vdc = 23.16 sfps = baseline (example: actual flow output varies from 1-5 volts)

0.900 Vdc = idR In Progress

1.000 Vdc = momentary state

2.326 Vdc = after 3 seconds. idR values are displayed now.

#### NAMUR Enabled HIGH

2.325 Vdc = 23.16 sfps = baseline (example: actual flow output varies from 1-5 volts)

5.250 Vdc = idR In Progress

1.000 Vdc = momentary state

2.326 Vdc = after 3 seconds. idR values are displayed now.

#### NAMUR Enabled Disabled

2.325 Vdc = 23.16 sfps = baseline (example: actual flow output varies from 1-5 volts)

1.000 Vdc = idR In Progress

2.326 Vdc = after 3 seconds. idR values are displayed now.

### Using Digital Outputs

Digital busses (includes HART, Modbus, and FOUNDATION Fieldbus/PROFIBUS) are mutually exclusive, meaning only one can be active at a time. When a particular digital output is specified at order time the unit is configured appropriately at the factory. Use the ST80/ST80L configuration software (*Configuration/Output*) to change the digital output selection. Refer to the ST80/ST80L Configuration Software manual **06EN003491** for details. Note that enabling a digital bus will deactivate the other digital bus currently in effect. [Figure 48](#) below shows the configuration software dialog box that appears when the user assigns **4-20 mA #1** to *HART Flow* with another digital bus already active.

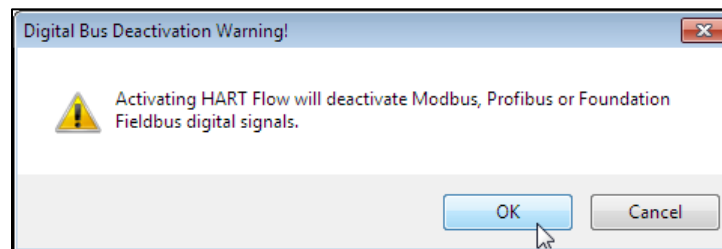

**Figure 48 – Digital Bus Deactivation Warning When Enabling HART**

FOUNDATION Fieldbus/PROFIBUS operation requires the optional Fieldbus/PROFIBUS add-on card installed on the main board. Refer to the FOUNDATION Fieldbus manual (**06EN003492**) and PROFIBUS manual (**06EN003493** or **06EN003494**) for operation details on these digital outputs.

## HART Operation

HART (Highway Addressable Remote Transducer) is a communication protocol that superimposes a low level digital data signal on a 4-20 mA current loop. The primary function of the instrument's HART interface is to present process data via process data commands 1, 3 and 9. Use the configuration software (*Configuration/Output*) to set the instrument to HART mode by assigning **4-20 mA #1** to *HART FLOW*. Refer to the ST80/ST80L Configuration Software manual **06EN003491** for details.

The ST80/ST80L does not implement the HART Burst mode. A HART master that supports HART 7.0 and higher is required. If using a HART communicator, a unit that supports HART 7.0 or higher is required (i.e. Emerson 475 Communicator). Connect the installation (factory/plant) HART wiring to the instrument as described in [HART Connections](#), page 25.

### Process Data Operation

The ST80/ST80L implements HART 7.0 while maintaining compatibility with earlier versions of the HART protocol. However, HART commands 1 and 3 have been simplified to only report the primary variable Flow. Use command 9 to access the full suite of available dynamic variables including temperature, totalizer, and others.

### ST80/ST80L HART Process Data Organization

This section describes how the instrument process data is organized under the HART command 9. For details on command 9 see the HART Specification "Universal Commands Specification" HCF\_SPEC-127, Revision 7.1 and the command 9 description on page 54.

#### ST80/ST80L Process Variable Slots

[Table 9](#) below lists the instrument's 6 process variables that are read by HART command 9, with each process variable assigned a slot number.

Not all the variables described in this section are available in all configurations of the flow meter. For example, the Flow Totalizer may be turned on or off.

The process variables include 3 flow classes or types of which only one class of flow is active at a time.

**Table 9 – ST80/ST80L HART Process Variables**

Slot #	Process Variable	HART Variable Code Description	Device Variable Code	Device Variable Classification
0	Volumetric Flow <sup>1</sup>	Primary Variable	0	66
1	Volume (Totalizer)	Secondary Variable	1	68
2	Mass Flow <sup>1</sup>	Primary Variable	2	72
3	Mass (Totalizer)	Secondary Variable	3	71
4	Velocity Flow <sup>1</sup>	Primary Variable	4	67
5	Temperature	Tertiary Variable	5	64

Note: 1. Only one active at a time.

#### Primary Variable Classifications

The instrument can provide flow data in unit types that span several HART classifications. Commands 50 and 51 are used to read and set, respectively, which flow variable will be mapped to the primary variable. The PV *device variable classification* can only be one of the following:

- 0: Volumetric Flow
- 2: Mass Flow
- 4: Velocity Flow

Since only PV is used in this manner, command 50 returns 250 for SV, TV, and QV. The setting of the *device variable classification* determines which class of flow-related variables is valid, and therefore displayed as implemented when variable slots are read by command 9.

### Device Description Files

A Device Description (DD) file lets the HART handheld or host software application fully configure any HART device for which it has a DD installed. The ST80/ST80L DD files are available for download (*pending*) from the FieldComm Group website:

<https://fieldcommgroup.org/registered-products/>

Search by **Manufacturer** (*Fluid Components International LLC*) to find the instrument's files under the product name: **FCI ST80/ST100A Series**. The posted DD files are contained in a zip archive with FCI's manufacturer ID and product device type hex values embedded in the filename (e.g., *hart.0000a6.a677.zip*).

**Note:** The ST80/ST80L and the ST100A Series are in the same product family.

Table 10 below summarizes the instrument's FieldComm Group device registration information.

**Table 10 – ST80/ST80L HART Field Device Registration Information**

Product Name	Product Type	HART Version	Mfgr. ID	Device Type	Dev. Revision
FCI ST80/ST100A Series	Flow	7	0x00A6	0xA677	01

#### EDDL Files

The ST80/ST80L EDDL (Electronic Device Description Language) files are support files that provide an extended description of each object in the Virtual Field Device (VFD), and provide information needed for a control system or host to understand the meaning of the data in the VFD including the human interface. The EDDL file can be thought as a “driver” for the device.

#### Loading the DD Files to the 475 Field Communicator

Use the “Easy Upgrade Utility” from EMERSON to load the DD files into the Field Communicator. Below is the procedure for how to load DD files into the 475-Field communicator.

Open the **Field Communicator Easy Upgrade Utility** program and click *Utilities* on the left hand menu. Select *Import DDs from a local source*. Then select the FCI files from the resulting List dialog and click on OK. See Figure 49 below.

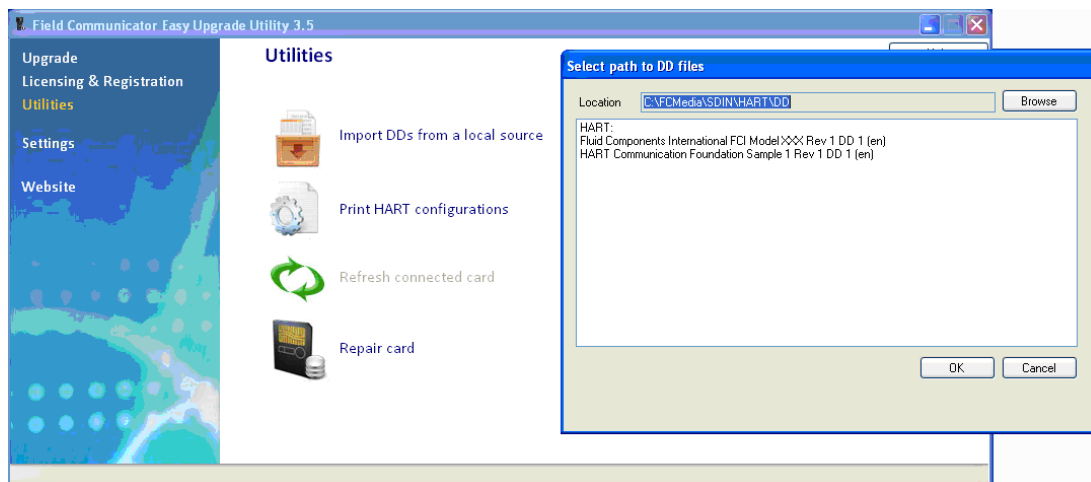

**Figure 49 – Field Communicator Easy Upgrade Utility, Import DD**

#### Service Data Operation

Shown below is example service information as provided by the Emerson 475 HART communicator with FCI's DD files loaded. The same information seen by the 475 is shown in the DCS (Distributed Control System) when the ST80/ST80L HART DD files are loaded. The screens shown below are a subset of the total 475 HART communicator information for the ST80/ST80L.

**Note:** The ST80/ST80L uses the same DD files as the ST100A Series. The handheld communicator screens will, therefore, show both ST80 and ST100A. ST100A-specific differences are noted in the text below.



**Root Menu**

Shown below is the Root Menu as displayed on the Emerson 475 HART communicator.



**Basic Setup (from Device Setup)**

The Basic Setup function includes the ability to review and change the engineering units of the process variables, review and change the plenum or pipe size, enable or disable the Totalizer, review and change device information, reset the operation of the ST80/ST80L to the factory settings, enable or disable the write protect, and PV Setup.



**Device Setup (from Root Menu)**

The Device Setup function is a gateway to ST80/ST80L device information, process data and setup, both basic and advanced. Additional options include K Factor display/adjust, totalizer reset, and customer flow limits.



**Process Data Example (from Device Setup)**

The Process Data screen lets you review process data including flow rate, temperature, pressure, and the process variable's 4-20 mA current loop output value.



**Process Data Time Example (from Device Setup)**

The Process Data Time screen lets you review the current process variable value and its engineering units, device status, and the current date and time (24-hour clock).



**Engineering Units Example (from Basic Setup)**



**Device Configuration (from Advance Setup ← Device Setup)**

Use the device configuration function to view/set up the flow meter's 4-20 mA current output channels. Raw DA counts are shown for 4 mA and 20 mA and the output variable is shown as *OFF, Flow, Temperature, or Pressure\**.

\*NOTE – Channel 3 setup and the pressure variable selection apply to ST100A Series only.



**Factory Reset (from Basic Setup)**

**CAUTION** – The Factory Reset command reloads the configuration and calibration parameters that were loaded into the instrument during the original calibration and setup. Any subsequent changes made to the calibration parameters configuration will be lost when the Factory Reset command is executed.



**Device Status (from Device Setup)**

Use the device status function to see the hex values of the Command 48 Additional Device Status (6-byte field, bytes 0-5). The topmost "Device status" shows the value of the "More Status Available" bit within the HART command response data field (b4 in 2<sup>nd</sup> byte). If b4 is set, more status is available and the subsequent error(s) shown in the Additional Device Status bytes (Command 48). If b4 is cleared, there is no additional status to report. Refer to [Command 48, Additional Device Status Bytes](#), page 68.



## Device Factory Calibration Example (from Advance Setup ← Device Setup)

The Device Factory Calibration function lets you review the limits that have been set for the Flow, Temperature, and Pressure\* process parameters.

\*NOTE – Pressure limits apply to ST100A Series only.



## HART Command List Reference

The HART commands are divided into three classes.

- Universal Commands
- Common Practice Commands
- Device Specific Commands

Barring no communication error, a field or slave device returns a response code as part of the 2-byte status response to a command. Refer to [Command Status Bytes](#) on page 66. The ST80/ST80L response codes listed in the following command summaries are a subset of the response codes listed in the HART specification.

### ST80/ST80L HART Universal Commands

The ST80/ST80L HART supports Universal Commands 0 through 22 and 38 and 48. Commands 4 and 5 are reserved under Universal Command Specification Rev. 7.1 (HCF\_SPEC-127, Revision 7.1) and not implemented in this specification. There is no HART command 10. [Table 11](#) below summarizes the instrument's HART Universal command set and the data associated with each command.

**Table 11 – HART Universal Commands**

<b>Command 0: Read Unique Identifier</b>			
	<b>Byte</b>	<b>Format</b>	<b>Description</b>
Request Data Bytes	None		
Response Data Bytes	0	Unsigned-8	254
	1–2	Enum	Expanded Device Type
	3	Unsigned-8	Minimum number of preambles from master to slave
	4	Unsigned-8	HART Protocol Revision Number: 7
	5	Unsigned-8	Device Revision Number
	6	Unsigned-8	Software Revision Number
	7	Unsigned-5	(Most Significant 5 Bits) Hardware Revision Level
	7	Enum	Physical Signaling Code: 00 = Bell 202 Current (4-20 mA)
	8	Bits	Flags: (Unused)
	9–11	Unsigned-24	Device ID
	12	Unsigned-8	Minimum number of preambles from the slave to master
	13	Unsigned-8	Maximum Number of Device Variables
	14–15	Unsigned-16	Configuration Change Counter
	16	Bits	Extended Field Device Status
	17–18	Enum	Manufacturer ID Code: 166 <sub>DEC</sub> /00A6 <sub>HEX</sub> (FCI)
	19–20	Enum	Private Label Distributor Code
	21	Enum	Device Profile = 1 "HART Process Automation Device"
Response Codes	See <a href="#">Table 16</a> , page 67, for response code list.		

<b>Command 1: Read Primary Variable (Flow Units, &amp; Flow Value)</b>			
	<b>Byte</b>	<b>Format</b>	<b>Description</b>
Request Data Bytes	None		
Response Data Bytes	0	Enum	Primary Variable Units Code
	1–4	Float	Primary Variable Value
Response Codes	See <a href="#">Table 16</a> , page 67, for response code list.		

<b>Command 2: Read Primary Variable Loop Current and Percent of Range</b>			
	<b>Byte</b>	<b>Format</b>	<b>Description</b>
Request Data Bytes	None		
Response Data Bytes	0-3	Float	Primary Variable Loop Current (mA)
	4-7	Float	Primary Variable Percent of Range (%)
Response Codes	See <a href="#">Table 16</a> , page 67, for response code list.		

<b>Command 3: Read Dynamic Variable (Flow) and Loop Current</b>			
	<b>Byte</b>	<b>Format</b>	<b>Description</b>
Request Data Bytes	None		
Response Data Bytes	0-3	Float	PV Loop Current: 4-20 mA
	4	Enum	PV HART Unit Code, Flow
	5-8	Float	PV Flow Value
Response Codes	See <a href="#">Table 16</a> , page 67, for response code list.		

<b>Command 6: Write Polling Address</b>			
	<b>Byte</b>	<b>Format</b>	<b>Description</b>
Request Data Bytes	0	Unsigned-8	Polling Address of Device
	1	Enum	Loop Current Mode
Response Data Bytes	0	Unsigned-8	Polling Address of Device
	1	Enum	Loop Current Mode
Response Codes	See <a href="#">Table 16</a> for response code list.		

<b>Command 7: Read Loop Configuration</b>			
	<b>Byte</b>	<b>Format</b>	<b>Description</b>
Request Data Bytes	None		
Response Data Bytes	0	Unsigned-8	Polling Address of Device
	1	Enum	Loop Current Mode
Response Codes	See <a href="#">Table 16</a> , page 67, for response code list.		

<b>Command 8: Read Dynamic Variable Classifications</b>			
	<b>Byte</b>	<b>Format</b>	<b>Description</b>
Request Data Bytes	None		
Response Data Bytes	0	Unsigned-8	Primary Variable Classification
	1-3	Unsigned-8	SV, TV and QV not used (Classification 0)
Response Codes	See <a href="#">Table 16</a> , page 67, for response code list.		

<b>Command 9: Read Device Variables with Status<sup>1</sup></b>			
	<b>Byte</b>	<b>Format</b>	<b>Description</b>
Request Data Bytes	0	Unsigned-8	Slot 0: Device Variable Code
	1	Unsigned-8	Slot 1: Device Variable Code
	2	Unsigned-8	Slot 2: Device Variable Code
	3	Unsigned-8	Slot 3: Device Variable Code
	4	Unsigned-8	Slot 4: Device Variable Code
	5	Unsigned-8	Slot 5: Device Variable Code
	6	Unsigned-8	Slot 6: Device Variable Code
	7	Unsigned-8	Slot 7: Device Variable Code
Response Data Bytes	0	Bits	Extended Field Device Status
	1	Unsigned-8	Slot 0: Device Variable Code
	2	Enum	Slot 0: Device Variable Classification
	3	Enum	Slot 0: Units Code
	4–7	Float	Slot 0: Device Variable Value
	8	Bits	Slot 0: Device Variable Status
	9	Unsigned-8	Slot 1: Device Variable Code
	10	Enum	Slot 1: Device Variable Classification
	11	Enum	Slot 1: Units Code
	12–15	Float	Slot 1: Device Variable Value
	16	Bits	Slot 1: Device Variable Status
	17	Unsigned-8	Slot 2: Device Variable Code
	18	Enum	Slot 2: Device Variable Classification
	19	Enum	Slot 2: Units Code
	20–23	Float	Slot 2: Device Variable Value
	24	Bits	Slot 2: Device Variable Status
	25	Unsigned-8	Slot 3: Device Variable Code
	26	Enum	Slot 3: Device Variable Classification
	27	Enum	Slot 3: Units Code
	28–31	Float	Slot 3: Device Variable Value
	32	Bits	Slot 3: Device Variable Status
	33	Unsigned-8	Slot 4: Device Variable Code
	34	Enum	Slot 4: Device Variable Classification
	35	Enum	Slot 4: Units Code
	36–39	Float	Slot 4: Device Variable Value
	40	Bits	Slot 4: Device Variable Status
	41	Unsigned-8	Slot 5: Device Variable Code
	42	Enum	Slot 5: Device Variable Classification
	43	Enum	Slot 5: Units Code
	44–47	Float	Slot 5: Device Variable Value
	48	Bits	Slot 5: Device Variable Status
	49	Unsigned-8	Slot 6: Device Variable Code
	50	Enum	Slot 6: Device Variable Classification
51	Enum	Slot 6: Units Code	
52–55	Float	Slot 6: Device Variable Value	
56	Bits	Slot 6: Device Variable Status	
57	Unsigned-8	Slot 7: Device Variable Code	
58	Enum	Slot 7: Device Variable Classification	
59	Enum	Slot 7: Units Code	
60–63	Float	Slot 7: Device Variable Value	
64	Bits	Slot 7: Device Variable Status	
65–68	Time	Slot 0: Data Time Stamp	
Response Codes	See <a href="#">Table 16</a> , page 67, for response code list.		

Note: 1. Command 9 takes in a variable list of parameters and similarly returns a variable length response.

<b>Command 11: Read Unique Identifier Associated with Tag</b>			
	<b>Byte</b>	<b>Format</b>	<b>Description</b>
Request Data Bytes	0–5	Packed	Tag, Packed ASCII
Response Data Bytes	0	Unsigned-8	254
	1–2	Enum	Expanded Device Type
	3	Unsigned-8	Minimum number of preambles from master to slave
	4	Unsigned-8	HART Protocol Revision Number: 7
	5	Unsigned-8	Device Revision Number
	6	Unsigned-8	Software Revision Number
	7	Unsigned-5	(Most Significant 5 Bits) Hardware Revision Level: 1
	7	Enum	Physical Signaling Code: 00 = Bell 202 Current (4-20 mA)
	8	Bits	Flags: (Unused)
	9–11	Unsigned-24	Device ID
	12	Unsigned-8	Minimum number of preambles from the slave to master
	13	Unsigned-8	Maximum Number of Device Variables
	14–15	Unsigned-16	Configuration Change Counter
	16	Bits	Extended Field Device Status
	17–18	Enum	Manufacturer ID Code: 166 <sub>DEC</sub> /00A6 <sub>HEX</sub> (FCI)
	19–20	Enum	Private Label Distributor Code
	21	Enum	Device Profile = 1 “HART Process Automation Device”
Response Codes	See <a href="#">Table 16</a> , page 67, for response code list.		

<b>Command 12: Read Message Contained Within Device</b>			
	<b>Byte</b>	<b>Format</b>	<b>Description</b>
Request Data Bytes	None		
Response Data Bytes	0–23	Bitstring	24-character message string
Response Codes	See <a href="#">Table 16</a> , page 67, for response code list.		

<b>Command 13: Read Tag, Descriptor, Date</b>			
	<b>Byte</b>	<b>Format</b>	<b>Description</b>
Request Data Bytes	None		
Response Data Bytes	0–5	Packed	Tag
	6–17	Packed	Descriptor
	18–20	Date	Date Code: Day, Month, Year (YR = setting year minus 1900)
Response Codes	See <a href="#">Table 16</a> , page 67, for response code list.		

<b>Command 14: Read Primary Variable (Flow) Transducer Information</b>			
	<b>Byte</b>	<b>Format</b>	<b>Description</b>
Request Data Bytes	None		
Response Data Bytes	0–2	Unsigned-24	Transducer Serial Number
	3	Enum	Transducer Units Code
	4–7	Float	Upper Transducer Limit
	8–11	Float	Lower Transducer Limit
	12–15	Float	Minimum Span
Response Codes	See <a href="#">Table 16</a> , page 67, for response code list.		

<b>Command 15: Read Device Information</b>			
	<b>Byte</b>	<b>Format</b>	<b>Description</b>
Request Data Bytes	None		
Response Data Bytes	0	Enum	Flow Alarm Selection Code
	1	Enum	Flow Transfer Function Code (not supported)
	2	Enum	Flow Upper and Lower Range Value Units Code
	3–6	Float	Flow Upper Range Value
	7–10	Float	Flow Lower Range Value
	11–14	Float	Flow Damping Value
	15	Enum	Write Protect Code
	16	Enum	Reserved
	17	Bits	Flow Analog Channel Flags (not supported)
Response Codes	See <a href="#">Table 16</a> , page 67, for response code list.		

<b>Command 16: Read Final Assembly Number</b>			
	<b>Byte</b>	<b>Format</b>	<b>Description</b>
Request Data Bytes	None		
Response Data Bytes	0–2	Unsigned-24	STAK ELECT ASSY #
Response Codes	See <a href="#">Table 16</a> , page 67, for response code list.		

<b>Command 17: Write Message Into Device</b>			
	<b>Byte</b>	<b>Format</b>	<b>Description</b>
Request Data Bytes	0–23	Packed	Message String Used by Master
Response Data Bytes <sup>1</sup>	0–23	Packed	Message String
Response Codes	See <a href="#">Table 16</a> , page 67, for response code list.		

Note: 1. The value returned in the response data bytes reflects the value actually used by the field device.

<b>Command 18: Write Tag, Descriptor, Date</b>			
	<b>Byte</b>	<b>Format</b>	<b>Description</b>
Request Data Bytes	0–5	Packed	Tag
	6–17	Packed	Descriptor Used by Master
	18–20	Date	Date Code Used by Master
Response Data Bytes <sup>1</sup>	0–5	Packed	Tag
	6–17	Packed	Descriptor
	18–20	Date	Date Code: Day, Month, Year (YR = setting year minus 1900)
Response Codes	See <a href="#">Table 16</a> , page 67, for response code list.		

Note: 1. The value returned in the response data bytes reflects the value actually used by the field device.

<b>Command 19: Write Final Assembly Number</b>			
	<b>Byte</b>	<b>Format</b>	<b>Description</b>
Request Data Bytes	0–2	Unsigned-24	STAK ELECT ASSY #
Response Data Bytes <sup>1</sup>	0–2	Unsigned-24	STAK ELECT ASSY #
Response Codes	See <a href="#">Table 16</a> , page 67, for response code list.		

Note: 1. The value returned in the response data bytes reflects the value actually used by the field device.



<b>Command 20: Read Long Tag</b>			
	<b>Byte</b>	<b>Format</b>	<b>Description</b>
Request Data Bytes	None		
Response Data Bytes	0–31	Latin-1	Long Tag
Response Codes	See <a href="#">Table 16</a> , page 67, for response code list.		

<b>Command 21: Read Unique Identifier Associated with Long Tag</b>			
	<b>Byte</b>	<b>Format</b>	<b>Description</b>
Request Data Bytes	0–31	Latin-1	Long Tag
Response Data Bytes	0	Unsigned-8	254
	1–2	Enum	Expanded Device Type
	3	Unsigned-8	Minimum Number Of Preambles From Master to Slave
	4	Unsigned-8	HART Protocol Revision Number: 7
	5	Unsigned-8	Device Revision Number
	6	Unsigned-8	Software Revision Number
	7	Unsigned-5	(Most Significant 5 Bits) Hardware Revision Level: 1
	7	Enum	Physical Signaling Code: 00 = Bell 202 Current (4-20 mA)
	8	Bits	Flags: (Unused)
	9–11	Unsigned-24	Device ID
	12	Unsigned-8	Minimum Number Of Preambles From Slave to Master
	13	Unsigned-8	Maximum Number of Device Variables
	14–15	Unsigned-16	Configuration Change Counter
	16	Bits	Extended Field Device Status
	17–18	Enum	Manufacturer ID Code: 166 <sub>DEC</sub> /00A6 <sub>HEX</sub> (FCI)
	19–20	Enum	Private Label Distributor Code
	21	Enum	Device Profile = 1 “HART Process Automation Device”
Response Codes	See <a href="#">Table 16</a> , page 67, for response code list.		

<b>Command 22: Write Long Tag</b>			
	<b>Byte</b>	<b>Format</b>	<b>Description</b>
Request Data Bytes	0–31	Latin-1	Long Tag
Response Data Bytes	0–31	Latin-1	Long Tag
Response Codes	See <a href="#">Table 16</a> , page 67, for response code list.		

<b>Command 38: Reset Configuration Changed Flag</b>			
	<b>Byte</b>	<b>Format</b>	<b>Description</b>
Request Data Bytes	0–1	Unsigned-16	Configuration Change Counter
Response Data Bytes	0–1	Unsigned-16	Configuration Change Counter
Response Codes	See <a href="#">Table 16</a> , page 67, for response code list.		

<b>Command 48: Read Additional Device Status</b>			
	<b>Byte</b>	<b>Format</b>	<b>Description</b>
Request Data Bytes	0–5	Bits	Device-Specific Status (only first 6 bytes used, see page 68 for additional info)
	6	Bits	Extended Device Status. Normally “0”; set to “1” (0x01) if maintenance is required.
	7	Bits	Device Operating Mode (not used, bit cleared to 0)
	8	Bits	Standardized Status 0 (not used, bit cleared to 0)
	9	Bits	Standardized Status 1 (not used, bit cleared to 0)
	10	Bits	Analog Channel Saturated (not used, bit cleared to 0)
	11	Bits	Standardized Status 2 (not used, bit cleared to 0)
	12	Bits	Standardized Status 3 (not used, bit cleared to 0)
	13	Bits	Analog Channel Fixed
	14–24	Bits	Device-Specific Status2 (not used, bit cleared to 0)
Response Data Bytes	0–5	Bits	Device-Specific Status (only first 6 bytes used, see page 68)
	6	Bits	Extended Device Status. Normally “0”; set to “1” (0x01) if maintenance is required.
	7	Bits	Device Operating Mode (not used, bit cleared to 0)
	8	Bits	Standardized Status 0 (not used, bit cleared to 0)
	9	Bits	Standardized Status 1 (not used, bit cleared to 0)
	10	Bits	Analog Channel Saturated (not used, bit cleared to 0)
	11	Bits	Standardized Status 2 (not used, bit cleared to 0)
	12	Bits	Standardized Status 3 (not used, bit cleared to 0)
	13	Bits	Analog Channel Fixed
	14–24	Bits	Device-Specific Status2 (not used, bit cleared to 0)
Response Codes	See <a href="#">Table 16</a> , page 67, for response code list.		

### ST80/ST80L HART Common Practice Commands

The ST80/ST80L supports Common Practice commands 35, 40, 42, 44, 45, 46, 50 and 51. [Table 12](#) below summarizes the instrument's HART Common Practice command set and the data associated with each command.

**Table 12 – HART Common Practice Commands**

<b>Command 35: Write Primary Variable (PV) Range Values</b>			
	<b>Byte</b>	<b>Format</b>	<b>Description</b>
Request Data Bytes	0	Unsigned-8	PV Upper and Lower Range Values Units Code
	1–4	Float	PV Upper Range Value (Customer Max. Flow Limit)
	5–8	Float	PV Lower Range Value (Customer Min. Flow Limit)
Response Data Bytes <sup>1</sup>	0	Unsigned-8	PV Upper and Lower Range Values Units Code
	1–4	Float	PV Upper Range Value
	5–8	Float	PV Lower Range Value
Response Codes	See <a href="#">Table 16</a> , page 67, for response code list.		

Note: 1. The value returned in the response data bytes reflects the rounded or truncated value actually used by the device.

<b>Command 40: Enter/Exit Fixed Current Mode</b>			
	<b>Byte</b>	<b>Format</b>	<b>Description</b>
Request Data Bytes <sup>1</sup>	0–3	Float	PV Fixed Current Level (mA units); "0" to Exit Fixed Current
Response Data Bytes	0–3	Float	Actual PV Current Level
Response Codes	See <a href="#">Table 16</a> , page 67, for response code list.		

Notes: 1. Specify a value (in mA) to drive Ch. 1 to a particular output value. Specify "0" to exit the fixed current mode.

<b>Command 42: Perform Device Reset (Soft Reset of Flow Meter)<sup>1</sup></b>			
	<b>Byte</b>	<b>Format</b>	<b>Description</b>
Request Data Bytes	None		
Response Data Bytes	None		
Response Codes	See <a href="#">Table 16</a> , page 67, for response code list.		

Note: 1. Send Command 42 (no data) to reset the instrument. No response is returned due to reboot.

<b>Command 44: Write Primary Variable Units</b>			
	<b>Byte</b>	<b>Format</b>	<b>Description</b>
Request Data Bytes	0	Enum	PV Units Code
Response Data Bytes <sup>1</sup>	0	Enum	PV Units Code
Response Codes	See <a href="#">Table 16</a> , page 67, for response code list.		

Note: 1. The value returned in the response data bytes reflects the value actually used by the device.

<b>Command 45: Trim DAC Zero – Measured Current Chan #1 (in mA)</b>			
	<b>Byte</b>	<b>Format</b>	<b>Description</b>
Request Data Bytes	0–3	Float	Ext. Measured Current Ch. #1 Level (4 mA Zero_DAC)
Response Data Bytes <sup>1</sup>	0–3	Float	Actual Measured Current Ch. #1 Level (4 mA Zero_DAC)
Response Codes	See <a href="#">Table 16</a> , page 67, for response code list.		

Note: 1. The value returned in the response data bytes reflects the rounded or truncated value actually used by the device.

<b>Command 46: Trim DAC Gain – Measured Current Chan #1 (in mA)</b>			
	<b>Byte</b>	<b>Format</b>	<b>Description</b>
Request Data Bytes	0–3	Float	Ext. Measured Current Ch. #1 Level (20 mA GainDAC)
Response Data Bytes <sup>1</sup>	0–3	Float	Actual Measured Current Ch. #1 Level (20 mA GainDAC)
Response Codes	See <a href="#">Table 16</a> , page 67, for response code list.		

Note: 1. The value returned in the response data bytes reflects the rounded or truncated value actually used by the device.

<b>Command 50: Read Dynamic Variable Assignments</b>			
	<b>Byte</b>	<b>Format</b>	<b>Description</b>
Request Data Bytes	None		
Response Data Bytes	0	Unsigned-8	Device Variable assigned to the primary variable.
	1–3	—	250 (Unused)
Response Codes	See <a href="#">Table 16</a> for response code list.		

<b>Command 51: Write Dynamic Variable Assignments</b>			
	<b>Byte</b>	<b>Format</b>	<b>Description</b>
Request Data Bytes	0	Unsigned-8	Device Variable assigned to the primary variable.
Response Data Bytes <sup>1</sup>	0	Unsigned-8	Device Variable assigned to the primary variable.
	1–3	—	250 (Unused)
Response Codes	See <a href="#">Table 16</a> for response code list.		

Note: 1. The value returned in the response data bytes reflects the value actually used by the device.

### ST80/ST80L HART Device Specific Commands

The ST80/ST80L Manufacturer Specific or Device Specific commands start at command 137. Use the device specific commands to setup and configure the ST80/ST80L instrument via HART. The ST80/ST80L device specific commands are grouped in functional categories as summarized in [Table 13](#) below.

**Table 13 – ST80/ST80L HART Device Specific Command Groupings**

Group No.	Description	Command Numbers
Group 1	Commands to set up and configure the instrument.	137, 138, 139, 140, 145, 146, 148, 149, 150, 159
Group 2	Commands to set up 4–20 mA output channels including the OUTZ, and OUTF parameters.	160, 161, 163, 164, 166, 167
Group 3	Commands to view individual FE process. The view is a snapshot of sensor data at the time of the request; i.e., it does not update in real time.	170
Group 4	Commands to display the factory-set calibrated limit of the instrument for flow, process temperature and pressure variables.	151, 154, 157
Group 5	Other Category – Commands outside the above listed groups.	159, 179, 180, 181, 182, 183, 184, 185, 186, 187, 188, 191, 193

[Table 14](#) below summarizes the instrument's HART Device Specific command set and the data associated with each command.

**Table 14 – HART Device Specific Commands**

Command 137: Read Totalizer And Rollover Values			
	Byte	Format	Description
Request Data Bytes	None	—	—
Response Data Bytes	0–3	Float	Totalizer
Response Codes	See <a href="#">Table 16</a> , page 67, for response code list.		

Command 138: Read Totalizer State			
	Byte	Format	Description
Request Data Bytes	None	—	—
Response Data Bytes	0	Unsigned-8	Totalizer State: 0 = OFF; 1 = ON
Response Codes	See <a href="#">Table 16</a> , page 67, for response code list.		

Command 139: Write Totalizer State			
	Byte	Format	Description
Request Data Bytes	0	Unsigned-8	Totalizer State: 0 = OFF; 1 = ON
Response Data Bytes	0	Unsigned-8	Totalizer State: 0 = OFF; 1 = ON
Response Codes	See <a href="#">Table 16</a> , page 67, for response code list.		

Command 140: Read Device Information			
	Byte	Format	Description
Request Data Bytes	None	—	—
Response Data Bytes	0–9	Bits	Device CO
	10–19	Bits	Device Serial Number
	20–23	Bits	Device Software Version
Response Codes	See <a href="#">Table 16</a> , page 67, for response code list.		

<b>Command 145: Read Customer Engineering Units</b>			
	<b>Byte</b>	<b>Format</b>	<b>Description</b>
Request Data Bytes	None	—	—
Response Data Bytes	0	Unsigned-8	Units Code for Flow
	1	Unsigned-8	Units Code for Temperature
	2	Unsigned-8	Units Code for Totalizer
	3	Unsigned-8	Units Code for Pressure
Response Codes	See <a href="#">Table 16</a> , page 67, for response code list.		

<b>Command 146: Write Customer Engineering Units</b>			
	<b>Byte</b>	<b>Format</b>	<b>Description</b>
Request Data Bytes	0	Unsigned-8	Units Code for Flow
	1	Unsigned-8	Units Code for Temperature
	2	Unsigned-8	Units Code for Totalizer (must match Flow units)
	3	Unsigned-8	Units Code for Pressure
Response Data Bytes	0	Unsigned-8	Units Code for Flow
	1	Unsigned-8	Units Code for Temperature
	2	Unsigned-8	Units Code for Totalizer
	3	Unsigned-8	Units Code for Pressure
Response Codes	See <a href="#">Table 16</a> , page 67, for response code list.		

<b>Command 148: Read Plenum Information (Pipe Size)</b>			
	<b>Byte</b>	<b>Format</b>	<b>Description</b>
Request Data Bytes	None	—	—
Response Data Bytes	0-3	Float	Pipe Height Value
	4-7	Float	Pipe Width (Diameter) Value
	8	Unsigned-8	Plenum Units Code
Response Codes	See <a href="#">Table 16</a> , page 67, for response code list.		

<b>Command 149: Write Plenum Information (Pipe Size)</b>			
	<b>Byte</b>	<b>Format</b>	<b>Description</b>
Request Data Bytes	0-3	Float	Pipe Height Value
	4-7	Float	Pipe Width (Diameter) Value
	8	Unsigned-8	Plenum Units Code
Response Data Bytes	0-3	Float	Pipe Height Value
	4-7	Float	Pipe Width (Diameter) Value
	8	Unsigned-8	Plenum Units Code
Response Codes	See <a href="#">Table 16</a> , page 67, for response code list.		

<b>Command 150: Write "Write Protect Mode"</b>			
	<b>Byte</b>	<b>Format</b>	<b>Description</b>
Request Data Bytes	0	Unsigned-8	Write Protect Mode: 0x00 = Disable; 0x01 = Enable
Response Data Bytes	0	Unsigned-8	Write Protect Mode: 0x00 = Disable; 0x01 = Enable
Response Codes	See <a href="#">Table 16</a> , page 67, for response code list.		

<b>Command 151: Read Calibration Flow Limits</b>			
	<b>Byte</b>	<b>Format</b>	<b>Description</b>
Request Data Bytes	None	—	—
Response Data Bytes	0–3	Float	Flow Lower Limit Value
	4–7	Float	Flow Upper Limit Value
Response Codes	See <a href="#">Table 16</a> , page 67, for response code list.		

<b>Command 154: Read Calibration Temperature Limits</b>			
	<b>Byte</b>	<b>Format</b>	<b>Description</b>
Request Data Bytes	None	—	—
Response Data Bytes	0–3	Float	Temperature Lower Limit Value
	4–7	Float	Temperature Upper Limit Value
Response Codes	See <a href="#">Table 16</a> , page 67, for response code list.		

<b>Command 157: Read Calibration Pressure Limits</b>			
	<b>Byte</b>	<b>Format</b>	<b>Description</b>
Request Data Bytes	None	—	—
Response Data Bytes	0–3	Float	Pressure Lower Limit Value
	4–7	Float	Pressure Upper Limit Value
Response Codes	See <a href="#">Table 16</a> , page 67, for response code list.		

<b>Command 159: Write Factory Restore</b>			
	<b>Byte</b>	<b>Format</b>	<b>Description</b>
Request Data Bytes <sup>1</sup>	None	—	None (no data)
Response Data Bytes	None	—	None (returns nothing)
Response Codes	See <a href="#">Table 16</a> , page 67, for response code list.		

Note: 1. Send Command 159 with no data to reload the instrument's factory default programming.

<b>Command 160: Write (4-20 mA) Output Channel #1 Parameters</b>			
	<b>Byte</b>	<b>Format</b>	<b>Description</b>
Request Data Bytes	0–1	Unsigned-16	D/A Setting for 4 mA Out (OUTZ1)
	2–3	Unsigned-16	D/A Setting for 4 mA Out (OUTF1)
	4	Unsigned-8	Channel #1 Out Variable
Response Data Bytes	0–1	Unsigned-16	D/A Setting for 4 mA Out (OUTZ1)
	2–3	Unsigned-16	D/A Setting for 4 mA Out (OUTF1)
	4	Unsigned-8	Channel #1 Out Variable
Response Codes	See <a href="#">Table 16</a> , page 67, for response code list.		

<b>Command 161: Read (4-20 mA) Output Channel #1 Parameters</b>			
	<b>Byte</b>	<b>Format</b>	<b>Description</b>
Request Data Bytes	None	—	—
Response Data Bytes	0–1	Unsigned-16	D/A Setting for 4 mA Out (OUTZ1)
	2–3	Unsigned-16	D/A Setting for 4 mA Out (OUTF1)
	4	Unsigned-8	Channel #1 Out Variable
Response Codes	See <a href="#">Table 16</a> , page 67, for response code list.		

<b>Command 163: Write (4-20 mA) Output Channel #2 Parameters</b>			
	<b>Byte</b>	<b>Format</b>	<b>Description</b>
Request Data Bytes	0-1	Unsigned-16	D/A Setting for 4 mA Out (OUTZ2)
	2-3	Unsigned-16	D/A Setting for 4 mA Out (OUTF2)
	4	Unsigned-8	Channel #2 Out Variable
Response Data Bytes	0-1	Unsigned-16	D/A Setting for 4 mA Out (OUTZ2)
	2-3	Unsigned-16	D/A Setting for 4 mA Out (OUTF2)
	4	Unsigned-8	Channel #2 Out Variable
Response Codes	See <a href="#">Table 16</a> , page 67, for response code list.		

<b>Command 164: Read (4-20 mA) Output Channel #2 Parameters</b>			
	<b>Byte</b>	<b>Format</b>	<b>Description</b>
Request Data Bytes	None	—	—
Response Data Bytes	0-1	Unsigned-16	D/A Setting for 4 mA Out (OUTZ2)
	2-3	Unsigned-16	D/A Setting for 4 mA Out (OUTF2)
	4	Unsigned-8	Channel #2 Out Variable
Response Codes	See <a href="#">Table 16</a> , page 67, for response code list.		

<b>Command 166: Write (4-20 mA) Output Channel #3 Parameters</b>			
	<b>Byte</b>	<b>Format</b>	<b>Description</b>
Request Data Bytes	0-1	Unsigned-16	D/A Setting for 4 mA Out (OUTZ3)
	2-3	Unsigned-16	D/A Setting for 4 mA Out (OUTF3)
	4	Unsigned-8	Channel #3 Out Variable
Response Data Bytes	0-1	Unsigned-16	D/A Setting for 4 mA Out (OUTZ3)
	2-3	Unsigned-16	D/A Setting for 4 mA Out (OUTF3)
	4	Unsigned-8	Channel #3 Out Variable
Response Codes	See <a href="#">Table 16</a> , page 67, for response code list.		

<b>Command 167: Read (4-20 mA) Output Channel #3 Parameters</b>			
	<b>Byte</b>	<b>Format</b>	<b>Description</b>
Request Data Bytes	None	—	—
Response Data Bytes	0-1	Unsigned-16	D/A Setting for 4 mA Out (OUTZ3)
	2-3	Unsigned-16	D/A Setting for 4 mA Out (OUTF3)
	4	Unsigned-8	Channel #3 Out Variable
Response Codes	See <a href="#">Table 16</a> , page 67, for response code list.		

<b>Command 170: Read Bank #1 Sensor Variables</b>			
	<b>Byte</b>	<b>Format</b>	<b>Description</b>
Request Data Bytes	None	—	—
Response Data Bytes	0-3	Float	Flow Value Sensor #1
	4-7	Float	Temperature Value Sensor #1
	8-11	Float	Pressure Value Sensor #1
	12-15	Float	Flow Value Sensor #2
	16-19	Float	Temperature Value Sensor #2
	20-23	Float	Pressure Value Sensor #2
	24-27	Float	Flow Value Sensor #3
	28-31	Float	Temperature Value Sensor #3
	32-35	Float	Pressure Value Sensor #3
	36-39	Float	Flow Value Sensor #4
	40-43	Float	Temperature Value Sensor #4
44-47	Float	Pressure Value Sensor #4	
Response Codes	See <a href="#">Table 16</a> , page 67, for response code list.		



<b>Command 179: Write/Set Calibration Group</b>			
	<b>Byte</b>	<b>Format</b>	<b>Description</b>
Request Data Bytes	0	Unsigned-8	Write/Set Calibration Group
Response Data Bytes	0	Unsigned-8	Write/Set Calibration Group
Response Codes	See <a href="#">Table 16</a> , page 67, for response code list.		

<b>Command 180: Read Calibration Group</b>			
	<b>Byte</b>	<b>Format</b>	<b>Description</b>
Request Data Bytes	0	Unsigned-8	Read Calibration Group
Response Data Bytes	0	Unsigned-8	Read Calibration Group
Response Codes	See <a href="#">Table 16</a> , page 67, for response code list.		

<b>Command 181: Write KFactor1</b>			
	<b>Byte</b>	<b>Format</b>	<b>Description</b>
Request Data Bytes	0-3	Float	Write KFactor1
Response Data Bytes	0-3	Float	Write KFactor1
Response Codes	See <a href="#">Table 16</a> , page 67, for response code list.		

<b>Command 182: Write KFactor2</b>			
	<b>Byte</b>	<b>Format</b>	<b>Description</b>
Request Data Bytes	0-3	Float	Write KFactor2
Response Data Bytes	0-3	Float	Write KFactor2
Response Codes	See <a href="#">Table 16</a> , page 67, for response code list.		

<b>Command 183: Write KFactor3</b>			
	<b>Byte</b>	<b>Format</b>	<b>Description</b>
Request Data Bytes	0-3	Float	Write KFactor3
Response Data Bytes	0-3	Float	Write KFactor3
Response Codes	See <a href="#">Table 16</a> , page 67, for response code list.		

<b>Command 184: Write KFactor4</b>			
	<b>Byte</b>	<b>Format</b>	<b>Description</b>
Request Data Bytes	0-3	Float	Write KFactor4
Response Data Bytes	0-3	Float	Write KFactor4
Response Codes	See <a href="#">Table 16</a> , page 67, for response code list.		

<b>Command 185: Read KFactor1</b>			
	<b>Byte</b>	<b>Format</b>	<b>Description</b>
Request Data Bytes	0-3	Float	Read KFactor1
Response Data Bytes	0-3	Float	Read KFactor1
Response Codes	See <a href="#">Table 16</a> , page 67, for response code list.		

<b>Command 186: Read KFactor2</b>			
	<b>Byte</b>	<b>Format</b>	<b>Description</b>
Request Data Bytes	0-3	Float	Read KFactor2
Response Data Bytes	0-3	Float	Read KFactor2
Response Codes	See <a href="#">Table 16</a> , page 67, for response code list.		

<b>Command 187: Read KFactor3</b>			
	<b>Byte</b>	<b>Format</b>	<b>Description</b>
Request Data Bytes	0–3	Float	Read KFactor3
Response Data Bytes	0–3	Float	Read KFactor3
Response Codes	See <a href="#">Table 16</a> , page 67, for response code list.		

<b>Command 188: Read KFactor4</b>			
	<b>Byte</b>	<b>Format</b>	<b>Description</b>
Request Data Bytes	0–3	Float	Read KFactor4
Response Data Bytes	0–3	Float	Read KFactor4
Response Codes	See <a href="#">Table 16</a> , page 67, for response code list.		

<b>Command 191: Totalizer Reset</b>			
	<b>Byte</b>	<b>Format</b>	<b>Description</b>
Request Data Bytes	0	Unsigned-8	Reset Key = 0x00
Response Data Bytes	0	Unsigned-8	Reset Key = 0x00
Response Codes	See <a href="#">Table 16</a> , page 67, for response code list.		

<b>Command 193: Read Process Variable and Time Stamp</b>			
	<b>Byte</b>	<b>Format</b>	<b>Description</b>
Request Data Bytes	0–13	Float	Read PV value, status, PV units, PV classification code, date code, and timestamp.
Response Data Bytes	0–13	Float	Read PV value, status, PV units, PV classification code, date code, and timestamp.
Response Codes	See <a href="#">Table 16</a> , page 67, for response code list.		

## HART Command Bit Assignments

### *Command Status Bytes*

The HART command response data field includes a status message in the first two bytes. The first byte (0) is the Comm Error/Response code. The second byte (1) is the Device status. Byte 0 indicates either a **communication error** or a **command-specific response code** if no communication error exists. Note that within the first byte, bit b7 is either *set* or *cleared* to indicate that the byte indicates a comm error or a command-specific response code, respectively. [Table 15](#) summarizes the command status bytes. [Table 16](#) summarizes the command-specific response codes.

Table 15 – Command Status Bytes, Bit Assignments

Byte	Bit	Error/Status Description	
		Communication Error	Response Code (No Comm Error)
Byte 0	0	<b>Reserved</b> – Bit cleared to zero.	Command-Specific Response Code (0-127) See <a href="#">Table 16</a> below.
	1	<b>Buffer Overflow</b> – The message was too long for the received buffer of the device.	
	2	<b>Reserved</b> – Bit cleared to zero.	
	3	<b>Longitudinal Parity Error</b> – The longitudinal parity calculated by the device did not match the check byte at the end of the message.	
	4	<b>Framing Error</b> – The stop bit of one or more bytes received by the device was not detected by the UART (i.e., a mark or 1 was not detected when a stop bit should have occurred).	
	5	<b>Overrun Error</b> – At least one byte of data in the receive buffer of the UART was overwritten before it was read (i.e. the slave did not process incoming byte fast enough).	
	6	<b>Vertical Parity Error</b> – The parity of one or more of the bytes received by the device was not odd	
	7	1: Set bit means byte represents communications error.	0: Cleared bit means byte represents response code.
Byte 1 <i>Device Status</i>	0	<b>Primary Variable Out of Limits</b> – The PV is beyond its operating limit.	
	1	<b>Non-Primary Variable Out of Limits</b> – A device variable not mapped to the PV is beyond its operating limits.	
	2	<b>Loop Current Saturated</b> – The loop current has reached its upper (or lower) endpoint limit and cannot increase (or decrease) any further.	
	3	<b>Loop Current Fixed</b> – The loop current is being held at a fixed value and is not responding to process variations.	
	4	<b>More Status Available</b> – More status information is available. Refer to <a href="#">Command 48, Additional Device Status Bytes</a> , page 68.	
	5	<b>Cold Start</b> – A power failure or device reset has occurred.	
	6	<b>Configuration Changed</b> – An operation was performed that changed the device's configuration.	
	7	<b>Device Malfunction</b> – The device detected a serious error or failure that compromises device operation.	

Table 16 – Command-Specific Response Codes

Code	(Class) Description	Code	(Class) Description
00	(Success) No command-specific errors	12	(Error) Upper Range value too low/Invalid mode
02	(Error) Invalid selection/Invalid Poll Address	13	(Error) Upper and Lower Range values out of limit
03	(Error) Passed parameter too large	14	(Warning) Span too small/Status byte mismatch
04	(Error) Passed parameter too small	16	(Mode Error) Access restricted
05	(Error) Too few data bytes received	18	(Error) Invalid units code
06	(Misc Error) Device-specific command error	29	(Error) Invalid Span
07	(Mode Error) In Write-Protect mode	30	(Error) Command response truncated
09	(Error) Invalid date code/Configuration change counter mismatch/Lower range value too high/Incorrect loop current mode or value	32	(Error) Busy
10	(Error) Lower Range value too low	64	(Error) Command not implemented
11	(Error) Upper Range value too high/Loop current not active (device in multidrop mode)	—	—

## Command 48, Additional Device Status Bytes

Table 17 below summarizes the Command 48 Additional Device Status bytes. This is a 6-byte field. The remaining status bytes are reserved for future use. A status bit is cleared (0) for no error. A status bit is set (1) when an error (or condition) is detected.

Table 17 – Command 48, Additional Device Status Bytes Bit Assignments

Byte	Bit	Error/Status Description	Class	Device Status Bits Set
Byte 0	0	Serious Device Error	Hardware	4
	1	Electronics Hardware Failure	Hardware	4
	2	Memory Error	Hardware	4
	3	Measurement Failure	Hardware	4, 7
	4	Maintenance Required	Hardware	4
	5	FRAM Failure	Hardware	4
	6	Power Supply Failure	Hardware	4
	7	Configuration Invalid	Hardware	4
Byte 1	0	Device Initialization Failed	Hardware	4
	1	Device Not Initialized	Hardware	4
	2	Electronic Temperature Too High	Hardware	4
	3	Flow Sensor Failure	Hardware	4, 7
	4	Flow Sensor Not Connected	Hardware	4,7
	5	Sensor Communication Failure	Hardware	4
	6	Totalizer Overflow	Hardware	4
	7	Flow Is Out Of Range	Hardware	4
Byte 2	0	Ethernet Communication Failure	Hardware	4
	1	USB Communications Failure	Hardware	4
	2	Industrial Communication Protocol Fail	Hardware	4
	3	Process Temperature Over Max Limit	Hardware	4
	4	Process Temperature Under Min Limit	Hardware	4
	5	Flow Sensor Heater Shorted	Hardware	4
	6	Not Used	—	—
	7	Flow Sensor Heater Open	Hardware	4
Byte 3	0	Not Used	—	—
	1	Not Used	—	—
	2	Flow Sensor A/D Counts Under Min Limit	Hardware	4
	3	Flow Sensor Delta-R Below Min Limit	Hardware	4
	4	FE Flow Above Limit	Hardware	4
	5	FE Process Temperature Over Min Limit	Hardware	4
	6	FE Process Temperature Under Max Limit	Hardware	4
	7	Component Error – TMP100	Hardware	4
Byte 4	0	Component Error – LTC2654	Hardware	4
	1	Component Error – CORE 4-20 mA Input ADS1100 (non-fatal)	Hardware	4
	2	Not Used	—	—
	3	I2C0 Failure	Hardware	4
	4	Component Error – Heater Monitor A/D	Hardware	4
	5	Component Error – 16-Bit I/O Expander	Hardware	4
	6	Component Error – Delta-R A/D Failure	Hardware	4
	7	Component Error – Reference-R A/D Failure	Hardware	4
Byte 5	0	Component Error -- FE FRAM	Hardware	4
	1	Component Error -- Active Excitation IC	Hardware	4
	2	Component Error -- Reference Excitation IC	Hardware	4
	3	STACK in Self Check Mode No Process Data Available	—	—
	4	Not Used	—	—
	5	Not Used	—	—
	6	Not Used	—	—
	7	FE in Internal Delta-R Check – process data not reliable (non-fatal)	—	—

**HART Engineering Units Codes**

Table 18 below summarizes the HART codes used to represent the instrument's engineering units.

**Table 18 – HART Engineering Units Codes****Temperature**

HART Code	Unit Description	HART Code	Unit Description
32	degrees Celsius	33	degrees Fahrenheit

**Volumetric Flow**

HART Code	Unit Description	HART Code	Unit Description
186	Standard Cubic Feet per Second (SCFS)	188	Standard Cubic Meter per Hour (SCMH)
123	Standard Cubic Feet per Minute (SCFM)	187	Standard Cubic Meter per Day (SCMD)
185	Standard Cubic Feet per Hour (SCFH)	176	Normal Liter per Second (NLPS)
184	Standard Cubic Feet per Day (SCFD)	175	Normal Liter per Minute (NLPM)
183	Normal Cubic Meters per Second (NCMS)	122	Normal Liter per Hour (NLPH)
182	Normal Cubic Meters per Minute (NCMM)	174	Normal Liter per Day (NLPD)
121	Normal Cubic Meters per Hour (NCMH)	180	Standard Liter per Second (SLPS)
181	Normal Cubic Meters per Day (NCMD)	179	Standard Liter per Minute (SLPM)
190	Standard Cubic Meter per Second (SCMS)	178	Standard Liter per Hour (SLPH)
189	Standard Cubic Meter per Minute (SCMM)	177	Standard Liter per Day (SLPD)

**Mass Flow**

HART Code	Unit Description	HART Code	Unit Description
80	Pounds per Second (LBPS)	75	Kilograms per Hour (KGPH)
81	Pounds per Minute (LBPM)	76	Kilograms per Day (KGPD)
82	Pounds per Hour (LBPH)	246	Metric Tonnes Per Second (TNPS)
83	Pounds per Day (LBPD)	77	Metric Tonnes Per Minute (TNPM)
73	Kilograms per Second (KGPS)	78	Metric Tonnes Per Hour (TNPH)
74	Kilograms per Minute (KGPM)	79	Metric Tonnes Per Day (TNPD)

**Velocity Flow**

HART Code	Unit Description	HART Code	Unit Description
20	Standard Feet per Second (SFPS)	21	Normal Meters per Second (NMPS)
116	Standard Feet per Minute (SFPM)	242	Normal Meters per Minute (NMPM)
240	Standard Feet per Hour (SFPH)	120	Normal Meters per Hour (NMPH)
241	Standard Feet per Day (SFPD)	243	Normal Meters per Day (NMPD)

**Totalizer**

HART Code	Unit Description	HART Code	Unit Description
43	Standard Cubic Meter (SCM)	168	Standard Cubic Feet (SCF)
63	Pound (LB)	166	Normal Cubic Meter (NCM)
61	Kilogram (KG)	41	Standard Liter (SL)
62	Metric Tonnes (TN)	167	Normal Liter (NL)

**Plenum**

HART Code	Unit Description	HART Code	Unit Description
47	inches	49	millimeters

**Pressure (ST100A Series only)**

HART Code	Unit Description	HART Code	Unit Description
175	PSIA	12	kPa A
06	PSIG	248	kPa G
01	in H <sub>2</sub> O (@60 °F)	170	cm H <sub>2</sub> O (g)
07	bar A	13	torr A
247	bar G	—	—

## Modbus Operation

The ST80/ST80L offers Modbus as one of its digital communication protocols, but unlike the other digital communication protocols Modbus only offers set up and configuration for the totalizer variable. Refer to [Modbus Connections](#) on page 27 for Modbus wiring info.

The ST80/ST80L Modbus physical layer uses the flow meter's asynchronous RS-485 serial port. There is no high speed Modbus over Ethernet. The ST80/ST80L offers the two basic traditional transmission serial interface modes: RTU and ASCII message coding.

The ST80/ST80L offers the process variable parameters (value) in floating point form, which are organized as single or double precision floating point registers. These registers are the 4000 and the 5000 group registers, both of which are accessed using Modbus 03 and 04 function codes. Refer to [Table 20](#), page 72, for an overview of the registers.

### Setting the ST80/ST80L for Modbus Operation

The ST80/ST80L Configuration Software application is used to select the instrument's digital communication protocol.

Using the supplied USB cable, connect the instrument's USB port to a USB port on the PC running the configurator software.

Launch the ST80/ST80L Configurator (with the PC already connected to the instrument). Select *Configuration* branch from the menu tree on the window's left side. Observe that the **Output** tab is selected. In the window's *Digital Output Selection* field, check whether or not **Modbus** is shown for *Digital Bus*. If not, use the *Digital Bus* pulldown menu to select **Modbus**. Then click **Send to Device** to program the ST80/ST80L (enter "2772" user password).

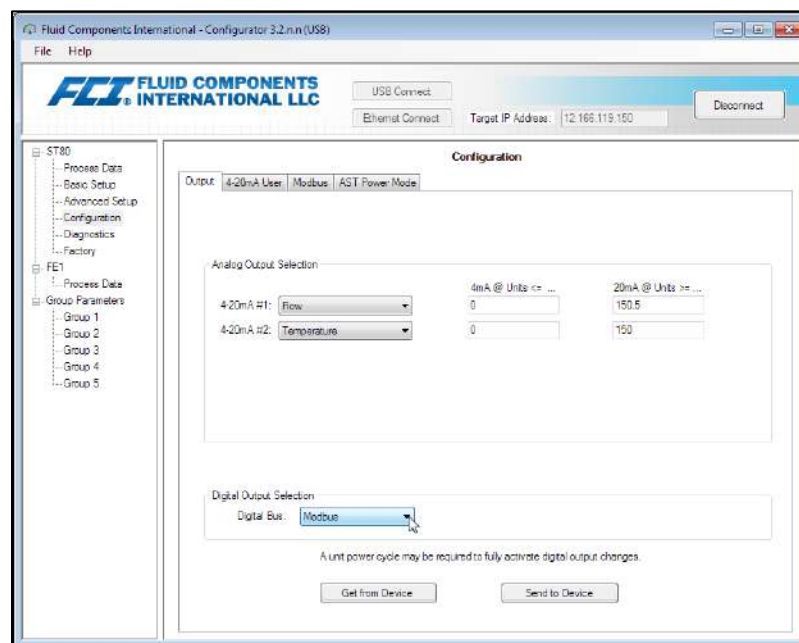

**Figure 50 – ST80/ST80L Configuration Software Output Tab with Modbus Selected**

Click the **Modbus** tab and configure the serial interface parameters (Node ID, Mode, Baud, Data Bits, Parity, and Stop Bits) as required for your application. Then click **Send to Device** to program the ST80/ST80L (enter "2772" user password). Refer to the ST80/ST80L Configuration Software manual [06EN003491](#) for details on configuring the digital bus and using the software.

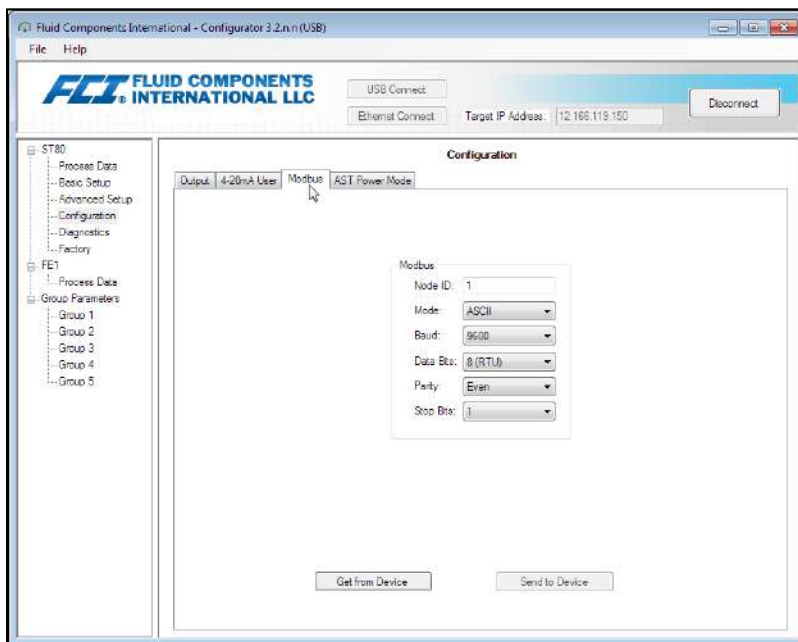

**Figure 51 – ST80/ST80L Configuration Software Modbus Tab, Serial Interface Configuration**

### ST80/ST80L Modbus Commands

With the Modbus protocol the instrument data is read and written via multiple register access. The following public function numbers are defined for communication with the ST80/ST80L: 03 and 04.

**Table 19 – ST80/ST80L Modbus Function Codes**

Function Code	Description	Register Group
03	Read Holding Registers: <ul style="list-style-type: none"> <li>Flow, Temperature, Totalizer, Pressure</li> <li>Flow unit, Temperature unit, Totalizer unit, Pressure unit</li> <li>Totalizer Enable/Disable Status register</li> </ul>	4xxxx
04	Read Input Registers: <ul style="list-style-type: none"> <li>Flow, Temperature, Totalizer, Pressure</li> <li>Flow unit, Temperature unit, Totalizer unit, Pressure unit</li> </ul>	3xxxx
06	Write Single Register: <ul style="list-style-type: none"> <li>Reset Totalizer counter</li> <li>Enable Totalizer</li> <li>Disable Totalizer</li> </ul>	4xxxx

See [Table 22](#) (page 75), [Table 23](#) (page 76), and [Table 24](#) (page 76) for Modbus engineering unit codes, exception codes, and register information, respectively.

### ST80/ST80L Process Data Registers

Two data type registers are set up in the ST80/ST80L to access the process data. One uses integer data registers (4000) and the other uses the Daniel extension data registers (5000).

All designated registers must be read for each variable value to extract the floating-point number. Conversion must be started manually with the 4000 registers. The Daniel extension handles the read and conversion automatically. To use the Daniel extension the master must support the Daniel extension function.

### Totalizer Description

The ST80/ST80L through the Modbus channel offers the flow Totalizer value through three different register groups organized into two forms of floating point data types. Registers 5103 and 5104, offer the flow Totalizer as a double precision floating point value in the Modbus Daniel extension protocol. Registers 4105, 4106, 4107, and 4108 offer the flow Totalizer as a double precision floating point value

in the Modbus standard integer register form. And lastly registers 4111, 4112, 4113, and 4114 offer the flow totalizer as a single precision floating point value in the Modbus standard register form. Because the Totalizer values can become a very large number, the single precision floating point presents the data as two register groups. Group 1 called TOTALIZER 1 holds the lower count with a defaulted count limit of 65,535.996. TOTALIZER 1 resets back to zero when the count limit is reached. Group 2 called TOTALIZER 2 holds the upper count and it increments by 1 every time the group 1 registers reach the 65,535.996 count or the set “Totalizer Max Limit” count. TOTALIZER 2 has a maximum count of 4,294,967,295, after which it resets back to zero.

The TOTALIZER 1 group maximum count value can be set to a lower value of the default value by the user. This is controlled by service registers 4115 and 4116 for which values above 65,535.996 are not permitted. The default value of 65,535.996 for TOTALIZER 1 provides a resolution 0.01 to the ST80/ST80L Totalizer value.

To reconstruct the double precision floating point value of the Totalizer using the single precision floating point registers do the following:  
 $Totalizer (DPFP) = Totalizer\ 2\ value \times Totalizer\ 1\ Max\ Value + Totalizer\ 1\ value$

**Table 20 – ST80/ST80L Modbus Process Data**

**Process Variable Values – Daniel Extension**

Variable/Parameter	Modbus Slave Register	Data Type	Access
Flow (Value)	5101	Float	Read
Temp (Value)	5102	Float	Read
Totalizer (Value) MS	5103	Float (D) <sup>1</sup>	Read
Totalizer (Value) LS	5104	Float (D) <sup>1</sup>	Read
Pressure (Value)	5105	Float	Read

**Process Variable Values – Integral Registers**

Variable/Parameter	Modbus Slave Register	Data Type <sup>2</sup>	Access
Flow MS (Value)	4101	Special1	Read
Flow LS (Value)	4102	Special1	Read
Temperature MS (Value)	4103	Special1	Read
Temperature LS (Value)	4104	Special1	Read
Totalizer MS (Value)	4105	Special2 (D) <sup>1</sup>	Read
Totalizer MS2 (Value)	4106	Special2 (D) <sup>1</sup>	Read
Totalizer LS2 (Value)	4107	Special2 (D) <sup>1</sup>	Read
Totalizer LS (Value)	4108	Special2 (D) <sup>1</sup>	Read
Pressure MS (Value)	4109	Special1	Read
Pressure LS (Value)	4110	Special1	Read

**Totalizer Value – Single Precision Floating Point (16 Bits)**

Variable/Parameter	Modbus Slave Register	Data Type	Access
Totalizer 1 MS (Value)	4111	Float	Read
Totalizer 1 LS (Value)	4112	Float	Read
Totalizer 2 MS (Value)	4113	Float	Read
Totalizer 2 LS (Value)	4114	Float	Read

**Process Variables – Engineering Unit Codes**

Variable/Parameter	Modbus Slave Register	Data Type	Access
Flow Eng. Units Code	4020	Integer	Read
Temp Eng. Units Code	4021	Integer	Read
Totalizer Eng. Units Code	4022	Integer	Read
Pressure Eng Units Code	4023	Integer	Read

**Instrument Status Codes**

Variable/Parameter	Modbus Slave Register	Data Type	Access
Device (Sensor 1) Status Code #1	4025	Integer	Read
Device (Sensor 1) Status Code #2	4026	Integer	Read

Notes: 1. (D) indicates double precision (64 bits).

2. **Data Type:** *Special1* is a collection of discrete registers that contain a single precision (32-bit) floating point value, and must be treated and interpreted as a single precision floating point number by the DCS or the PLC. *Special2* is a collection of discrete registers that contain a double precision (64-bit) floating point value, and must be treated and interpreted as a double precision floating point number by the DCS or the PLC.



**ST80/ST80L Modbus Service Registers**

The ST80/ST80L Modbus supports service registers **Totalizer Reset** and **Totalizer Start/Stop**.

- Reset Command for Totalizer – Use the Function 03 holding command via 4117 integer register to manually reset the ST80/ST80L totalizer count. This is a write only command. If another master has control on write, the function returns a “write protected” error message.
- Start/Stop Command for Totalizer – Use the Function 03 holding command via 4118 integer register to manually start or stop the totalizer count. This is a read/write command. If another master has control on write, the function returns a “write protected” error message.

**Table 21 – Modbus Service Data -- Service and Setup Functions**

Variable/Parameter	Modbus Slave Register	Data Type	Access
Totalizer Reset To reset the totalizer write 0xABCD	4117	Integer	Write Only (Function 03)
Totalizer Start/Stop To start the totalizer write 0x01 To stop the totalizer write 0x00	4118	Integer	Read/Write (Function 03) Read (Function 04)
Totalizer 1 Max MS	4115	Float	Read/Write (Function 03)
Totalizer 1 Max LS	4116	Float	Read/Write (Function 03)

**Examples of Totalizer Service Register Access using ModScan32**

ModScan32 is a Windows-based utility by WinTECH Software that lets a PC operate as a Modbus master device for testing Modbus systems. Connect the instrument’s Modbus terminals to one of the host PC’s COM/USB port (a USB connection will require a USB to RS-485 Serial Adapter).

**Note:** Modbus protocol addresses are zero-based, which means the public address values will be offset by “1” relative to the protocol address value.

**Checking the Totalizer 1 (Lower Count) Value**

1. To read the totalizer value, launch ModScan32 and set the data definition (Registers 4111 and 4112) in the Display Definition dialog box as shown in the figure below. (Pull down *Data Definition* from **Setup** menu or click the *Data Definition* icon in the toolbar). (Set Length value to “2” to include the 2<sup>nd</sup> subsequent register, 4112.) Click **OK** when done.

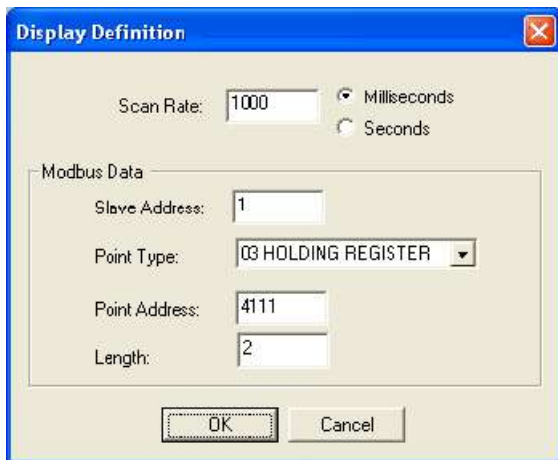

2. Once data is defined, select **Connect** from the *Connection* pull-down menu, which displays the Connection Details dialog shown below. Set the serial parameters and protocol (click **Protocol Selections**) as required for your application.

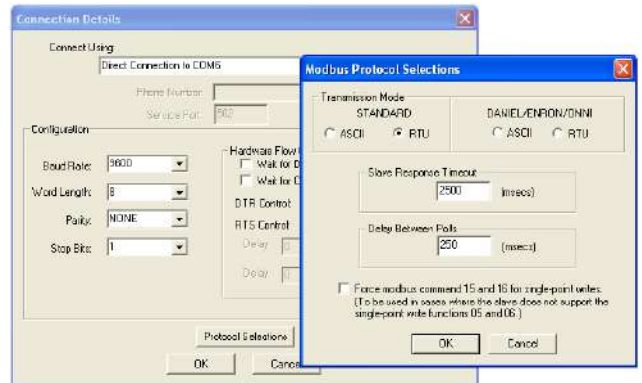

3. After entering the appropriate connection details and clicking **OK**, the ModScan32 master then attaches itself to the Modbus device (ST80/ST80L) as shown in the figure below. The register value displays in the bottom, gray part of the window.

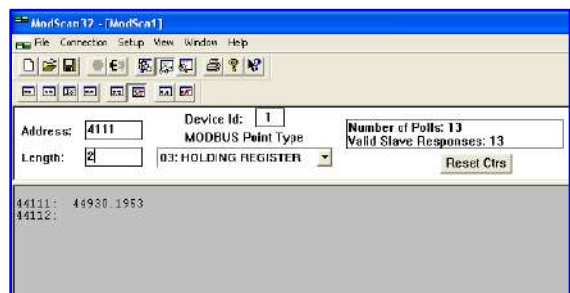

### Checking the Totalizer 2 (Upper Count/Rollover Count) Value

- Referring to [Checking the Totalizer 1 \(Lower Count\) Value](#) above, repeat step 1, but specify register #4113 instead (*Length* = 2).
- Repeat step 2 above (skip if already configured).
- See the figure below for a “Rollover count” number example.



### Checking/Setting the Totalizer Max. Value

- Referring to [Checking the Totalizer 1 \(Lower Count\) Value](#) above, repeat step 1, but specify register #4115 instead (*Length* = 2).
- Repeat step 2 above (skip if already configured).
- See the figure below for a “Ceiling value” number example.

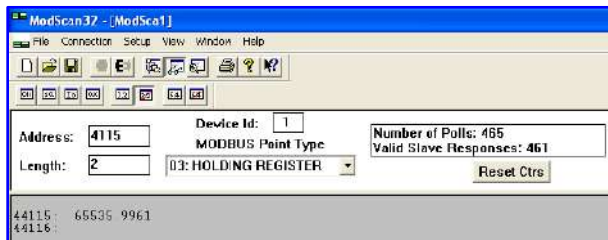

### Starting/Stopping the Totalizer Count

- Referring to [Checking the Totalizer 1 \(Lower Count\) Value](#) above, repeat step 1, but specify register #4118 instead (*Length* = 1).
- Repeat step 2 above (skip if already configured).
- Double click on the register number (see pointer in the figure below). A pop-up *Write Register* dialog displays. Enter the defined value (1 = start or 0 = stop) in the window’s value field, and then click **Update**.

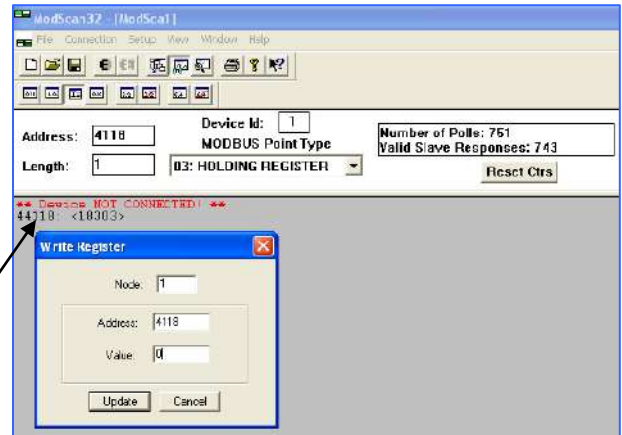

### Resetting the Totalizer Count

- Referring to [Checking the Totalizer 1 \(Lower Count\) Value](#) above, repeat step 1, but specify register #4117 instead (*Length* = 1).
- Repeat step 2 above (skip if already configured).
- Double click on the register number (see pointer in the figure below). A pop-up *Write Register* dialog displays. Enter the defined hex value, 0xABCD, in the window’s value field, and then click **Update**.

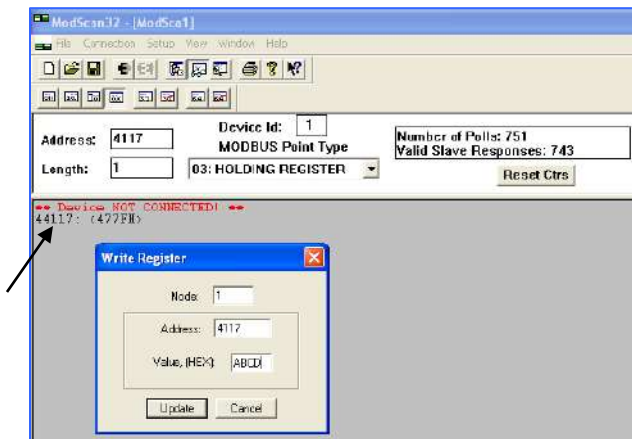

**Modbus Engineering Unit Codes Table**

Table 22 below summarizes the Modbus codes used to represent the instrument's engineering units.

**Table 22 – ST80/ST80L Modbus Engineering Unit Codes****Temperature**

Modbus Code	Unit Description	Modbus Code	Unit Description
66	degrees Celsius	71	degrees Fahrenheit

**Volumetric Flow**

Modbus Code	Unit Description	Modbus Code	Unit Description
90	Standard Cubic Feet per Second (SCFS)	188	Standard Cubic Meter per Hour (SCMH)
67	Standard Cubic Feet per Minute (SCFM)	187	Standard Cubic Meter per Day (SCMD)
72	Standard Cubic Feet per Hour (SCFH)	68	Normal Liter per Second (NLPS)
91	Standard Cubic Feet per Day (SCFD)	96	Normal Liter per Minute (NLPM)
94	Normal Cubic Meters per Second (NCMS)	97	Normal Liter per Hour (NLPH)
79	Normal Cubic Meters per Minute (NCMM)	98	Normal Liter per Day (NLPD)
78	Normal Cubic Meters per Hour (NCMH)	180	Standard Liter per Second (SLPS)
95	Normal Cubic Meters per Day (NCMD)	179	Standard Liter per Minute (SLPM)
190	Standard Cubic Meter per Second (SCMS)	178	Standard Liter per Hour (SLPH)
189	Standard Cubic Meter per Minute (SCMM)	177	Standard Liter per Day (SLPD)

**Mass Flow**

Modbus Code	Unit Description	Modbus Code	Unit Description
80	Pounds per Second (LBPS)	75	Kilograms per Hour (KGPH)
65	Pounds per Minute (LBPM)	93	Kilograms per Day (KGPD)
76	Pounds per Hour (LBPH)	246	Metric Tonnes Per Second (MT/S)
92	Pounds per Day (LBD)	77	Metric Tonnes Per Minute (MT/M)
73	Kilograms per Second (KGPS)	78	Metric Tonnes Per Hour (MT/H)
74	Kilograms per Minute (KGPM)	79	Metric Tonnes Per Day (MT/D)

**Velocity Flow**

Modbus Code	Unit Description	Modbus Code	Unit Description
70	Standard Feet per Second (SFPS)	86	Normal Meters per Second (NMPS)
83	Standard Feet per Minute (SFPM)	87	Normal Meters per Minute (NMPM)
84	Standard Feet per Hour (SFPH)	88	Normal Meters per Hour (NMPH)
85	Standard Feet per Day (SFPD)	89	Normal Meters per Day (NMPD)

**Totalizer**

Modbus Code	Unit Description	Modbus Code	Unit Description
43	Standard Cubic Meter (SCM)	190	Standard Cubic Feet (SCF)
180	Pound (LB)	194	Normal Cubic Meter (NCM)
173	Kilogram (KG)	41	Standard Liter (SL)
199	Metric Tonnes (TN)	168	Normal Liter (NL)

**Plenum**

Modbus Code	Unit Description	Modbus Code	Unit Description
47	inches	49	millimeters

**Pressure (applicable to ST100A Series only)**

Modbus Code	Unit Description	Modbus Code	Unit Description
01	PSIA	07	kPa A
02	PSIG	08	kPa G
03	in H <sub>2</sub> O (@60 °F)	09	cm H <sub>2</sub> O (g)
05	bar A	11	torr A
06	bar G	—	—

**Modbus Exception Codes Table**

Table 23 below summarizes the possible Modbus exception codes for the ST80/ST80L.

**Table 23 – ST80/ST80L Modbus Exception Codes**

Code	Exception	Description
02	Illegal Data Address	The Data address received in the query is not an allowable address for the master/slave
03	Illegal Data Value	A value contained in the query data field is not an allowable value for master/slave

**Modbus Variables and Registers Map Table**

Table 24 below summarizes the Modbus variables and registers for the ST80/ST80L.

**Table 24 – ST80/ST80L Modbus Variables and Registers Map**

Variables/Parameter	Modbus Register	Data Type	Access
Flow MS (of float32 value)	4100	16 bit integer	Read
Flow LS (of float32 value)	4101	16 bit integer	Read
Temp. MS (of float32 value)	4102	16 bit integer	Read
Temp. LS (of float32 value)	4103	16 bit integer	Read
Totalizer1 MS (of float64 value)	4104	16 bit integer	Read
Totalizer1 LS (of float64 value)	4105	16 bit integer	Read
Totalizer2 MS (of float64 value)	4106	16 bit integer	Read
Totalizer2 LS (of float64 value)	4107	16 bit integer	Read
Pressure MS (of float32 value)	4108	16 bit integer	Read
Pressure LS (of float32 value)	4109	16 bit integer	Read
Totalizer Modulo MS (of float32 value)	4110	16 bit integer	Read
Totalizer Modulo LS (of float32 value)	4111	16 bit integer	Read
Totalizer Rollover MS (of float32 value)	4112	16 bit integer	Read
Totalizer Rollover LS (of float32 value)	4113	16 bit integer	Read
Reset Totalizer (input "ABCD" hex)	4116	16 bit integer	Write
Enable/Disable Totalizer (1 = Enable, 0= Disable)	4117	16 bit integer	Read/Write
Flow Unit	4119	16 bit integer	Read
Temperature Unit	4120	16 bit integer	Read
Totalizer Unit	4121	16 bit integer	Read
Pressure Unit	4122	16 bit integer	Read
Status Code 1	4124	16 bit integer	Read
Status Code 2	4125	16 bit integer	Read
Status Code 3	4126	16 bit integer	Read
Flow value	5101	Float32	Read
Temperature value	5102	Float32	Read
Totalizer MS (of float64 value)	5103	Float32	Read
Totalizer LS (of float64 value)	5104	Float32	Read
Pressure value	5105	Float32	Read

## 4 MAINTENANCE

**Warning:** To avoid hazards to personnel, ensure that all environmental isolation seals are properly maintained.

**Caution:** The flow transmitter contains electrostatic discharge (ESD) sensitive devices. Use standard ESD precautions when handling the flow transmitter. See [ESD Precautions](#), page 16 for details.

### Introduction

The flow meter needs very little maintenance. There are no moving parts or mechanical parts subject to wear in the flow meter. The flow element that is exposed to the process media is all welded stainless steel construction. The flow element is only subject to chemical attack based on the corrosion relationship between the RTD thermowell material and process media.

### General Maintenance

Without detailed knowledge of the environmental parameters of the application surroundings and process media, FCI cannot make specific recommendations for the periodic inspection, cleaning, or testing procedures. However, some suggested general guidelines for maintenance steps are offered below. Use operation experience to establish the frequency of each type of maintenance.

#### **Calibration**

To ensure compliance with EPA 40 CFR Part 98, Subparts A and HH, FCI recommends checking the calibration of the ST80/ST80L flow meter every 24 months and recalibrating the instrument if required.

Note that additional regional, state, or company guidelines may recommend more frequent (e.g., annual) verifications or recalibrations or both. FCI recommends periodic cleaning of probes and enclosures.

#### **Electrical Connections**

Periodically inspect the wiring for secure connections to the terminal blocks. Verify that terminal connections are tight and physically sound with no sign of corrosion.

#### **Remote Enclosures**

Verify that the moisture barriers and seals that protect the local and remote enclosures are intact. Make sure no water has intruded.

#### **Electrical Wiring**

Periodically inspect the power cable, flow element cable(s) and input/output cables. Check the conductors for corrosion and the cable insulation for signs of deterioration.

#### **Flow Element Connections**

Verify that all seals are performing properly and that there is no leakage of the process media. Check for deterioration of the gaskets and environmental seals used.

#### **Flow Element Assembly**

Periodically remove the flow element for inspection based on historical evidence of debris, foreign matter, or scale build-up. Also the flow element can be removed at appropriate plant shutdown schedules. Check for corrosion, stress cracking, and build-up of oxides, salts, or foreign substances. The thermowells must be free of excessive contaminants and be physically intact. Any build-up could cause faulty readings. Clean the flow element as needed with a soft brush and available solvents (compatible with stainless steel).

**Power Fuse Replacement**

**Warning:** Make sure system power is OFF before replacing the fuse.

Input power overload protection is provided by a clip-mounted SMT fuse. [Table 25](#) below summarizes the ST80/ST80L power fuse. Open the blind lid (refer to instructions in [Accessing the I/O Connectors](#), page 21) to access the power fuse. The fuse is on the opposite side of the P1 power connector near the edge of the power supply board. See [Figure 52](#) below. Although a plastic shield covers this area of the board, the fuse remains accessible.

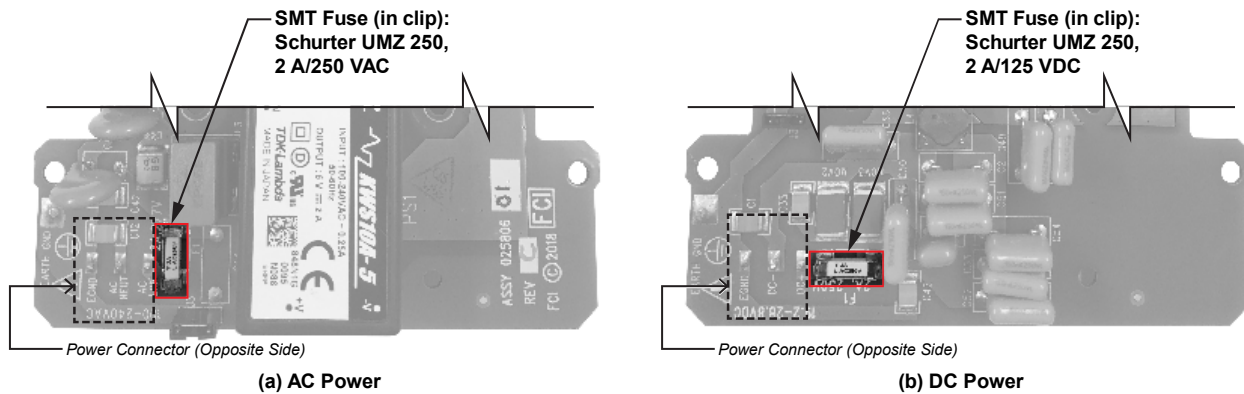

C01425-1-1

**Figure 52 – Fuse Location, Power Supply Board**

**Checking/Replacing the Fuse**

To check the SMT fuse first turn instrument power OFF. Replace a fuse with obvious damage (e.g., burnt, broken). Take a resistance reading across the fuse (fuse clip ends). See [Figure 52](#) above. Any reading other than a short (i.e., open circuit) indicates a blown fuse. Replace with the appropriate Schurter UMZ 250 fuse as listed in [Table 25](#) below. Reinstall the blind lid.

**Table 25 – Power Fuse Summary**

Qty	FCI Assembly P/Ns	Description	Mfgr. P/N	FCI P/N
1	025806-01 (AC-DC Power Supply)	SMT fuse (in clip), Schurter UMZ 250, 2 A, 250 VAC/125 VDC, time-lag	3404.2419.11	026095-02
1	025810-01 (DC-DC Power Supply)			

## Lithium Battery Replacement

A 3-volt lithium coin cell battery powers the ST80/ST80L real time clock (RTC). Typical service life of the battery is two years. Replace the battery every two years with the CR2450N coin cell battery listed in [Table 26](#) below.

**Table 26 – Lithium Coin Cell Battery Summary**

Qty	FCI Assembly P/Ns	Description	Mfgr. P/N	FCI P/N
1	025740-01 (Main Board)	3V Lithium battery type CR2450N, 540 mAh, temperature range: -40 °C – +85 °C, Manufacturer: <b>Renata</b>	CR2450N	022038-01

**Caution:** Use only the recommended industrial spec battery listed above. A consumer grade battery will not fit well in the holder and is prone to leakage or reduced performance or both when used in an industrial environment.

Disassemble the electronics to access the battery. [Figure 53](#) below gives an exploded view of the instrument. Remove the instrument's blind lid (refer to instructions in [Accessing the I/O Connectors](#), page 21) and follow the disassembly instructions below (skip steps 3 through 6 if unit has no display). The number callouts in the figure correspond to the numbered steps below.

**Warning:** Make sure system power is OFF before replacing the battery.

1. Remove all user cabling/wiring from the instrument connectors, and then pull all cable/wiring from the cable/wiring ports.
2. Using a 3 mm hex key, remove 2X M4 socket head cap screws securing electronics/cage assembly to housing, and 1X M4 socket head cap screw securing ground wire to housing. Remove electronics/card cage assembly from housing.
3. Separate bezel/HMI sensor assembly from the cage by pulling straight out.
4. Remove HMI jumper cable from the pin socket at the top the bezel/HMI sensor assembly ([Figure 53](#)).
5. Remove 3X 18-8 drive screws securing the display to the cage. Carefully pull the display assembly away from the cage to expose the FFC (flat flexible cable) cable.
6. Open the FFC cable connector on the main board: Pull the FFC connector lock tab out and then up (away from the board). Once the lock tab is opened, pull the FFC cable from the connector. Refer to the FFC connector detail in [Figure 53](#). Carefully set aside the fully detached display assembly.
7. Remove 2X nylon snap rivets securing electronics assembly to the cage, and then slide electronics assembly out to clear the cage.
8. Pull the lithium coin battery from its holder on the main board.
9. Install replacement battery type CR2450N in the coin cell holder with the positive (+) side facing the main board connectors. Use the replacement battery listed in [Table 26](#) above.
10. Reassembly is reverse of removal. (Make sure FFC display cable is fully inserted and square in connector before pushing the lock tab back into closed position.)

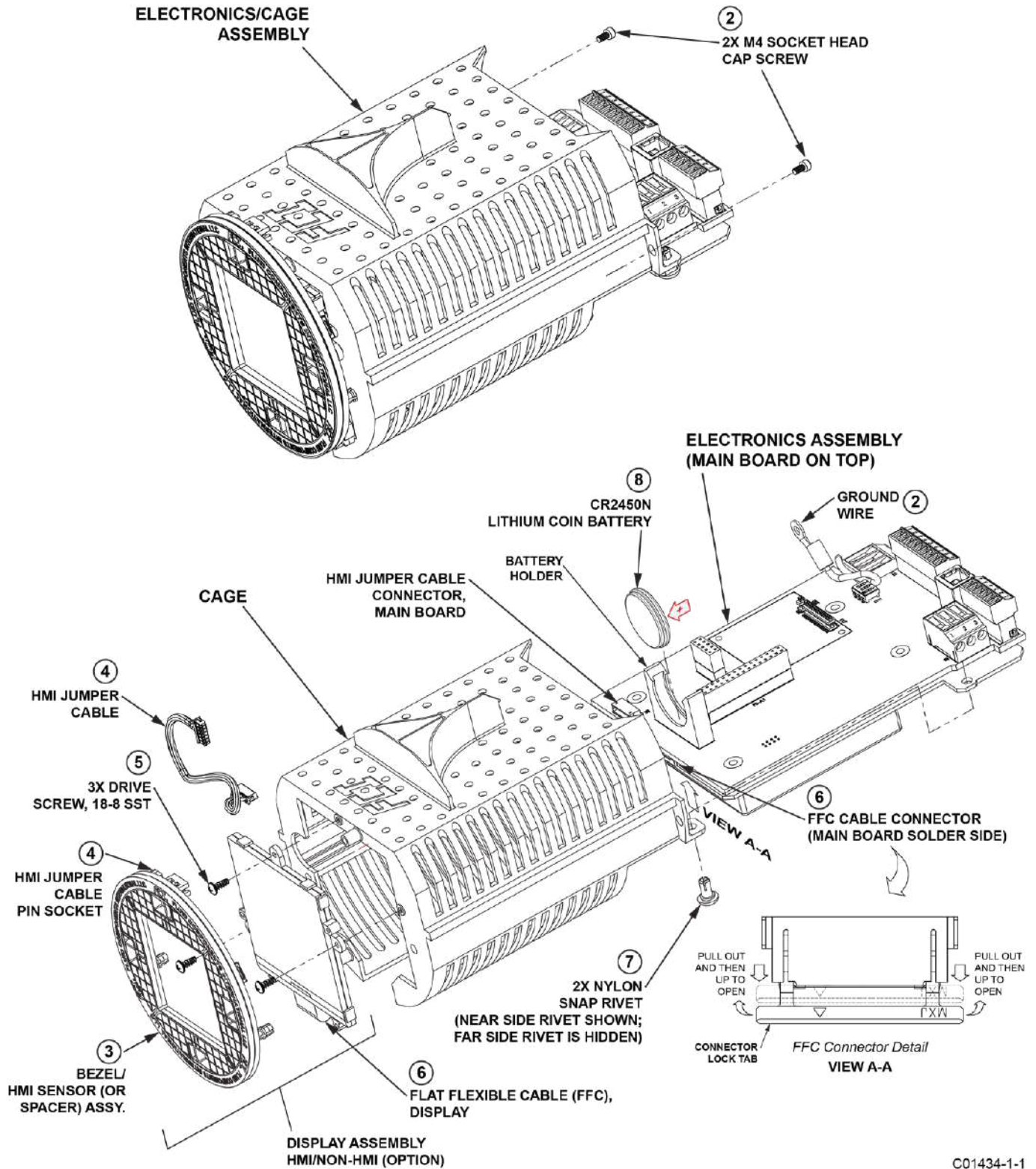

Figure 53 – Instrument Disassembly for Lithium Coin Cell Battery (CR2450N) Replacement



## 5 TROUBLESHOOTING

**Warning:** Instrument testing/troubleshooting limited to qualified personnel only. The operator assumes all responsibilities for safe practices while troubleshooting.

**Caution:** The flow transmitter contains electrostatic discharge (ESD) sensitive devices. Use standard ESD precautions when handling the flow transmitter. See [ESD Precautions](#), page 16 for details.

### Non-Maintenance Observations

At this point, observe the system setup to verify operation. No disassembly or testing is required at this time.

#### **Check Serial Numbers**

Verify that the serial number of the flow element(s) and the flow transmitter are the same. The flow element(s) and the flow transmitter are a matched set. Neither can work independently of the other nor can they be swapped with similar units from another system.

#### **Check Input Power**

Check for intact fuses. Verify that the AC power source is connected and turned on.

#### **Check Instrument Installation**

Review the instrument installation information given in the Installation section to verify correct mechanical and electrical installation. Be sure the connectors are firmly mated, and the wires are firmly attached to the connector. (Be sure the wires are inserted between the metal clamps and not between the clamp and plastic connector enclosure.) Verify correct wiring per wiring diagram in [APPENDIX A](#), page 93.

#### **Check for Moisture**

Check for moisture in the enclosures. Moisture on the electronics can cause faulty operation.

If a component of the process media is near its saturation temperature, then the component may condense on the sensing points. Liquid on the sensing points can cause measurement errors.

#### **Check Application Design Requirements**

Application design problems usually occur with first time application instruments, although the design should also be checked on instruments that have been in operation for some time. If the application design does not match field conditions, errors occur.

1. Review the application design with plant operation personnel and plant engineers.
2. Ensure that plant equipment such as pressure and temperature instruments conform to the actual conditions.
3. Verify operating temperature, operating pressure, line size, and gas medium.

#### **Check the General Process**

Check all inputs and outputs to the system. Verify pump ratings and check damper or valves that might be open or closed causing the flow to be different from that which would be expected.

**Verify Standard vs. Actual Process Conditions**

The flow meter measures the mass flow rate. The mass flow rate is the mass of the gas flowing through a pipe per time. Other flow meters, such as an orifice plate or a pitot tube, measure the volumetric flow rate. The volumetric flow rate is the volume of gas per time. If the readings displayed do not agree with another instrument, some calculations may be necessary before comparing them. To calculate the mass flow rate and the volumetric flow rate the pressure and temperature at the point of measurement must be known. Use the following equation to calculate the mass flow rate (Standard Volumetric Flow rate) for the other instrument.

**Equation:**

$$Q_s = Q_A \times \frac{P_A}{T_A} \times \frac{T_s}{P_s}$$

Where:

$Q_A$	=	Volumetric Flow	$Q_s$	=	Standard Volumetric Flow
$P_A$	=	Actual Pressure	$T_A$	=	Actual Temperature
$P_s$	=	Standard Pressure	$T_s$	=	Standard Temperature

Pressure in PSIA and Temperature is in degrees Rankine

**Example:**

$$\begin{array}{ll} Q_A = 1212.7 \text{ ACFM} & Q_s = 1485 \text{ SCFM} \\ P_A = 19.7 \text{ PSIA} & T_A = 120^\circ\text{F} (580^\circ\text{R}) \\ P_s = 14.7 \text{ PSIA} & T_s = 70^\circ\text{F} (530^\circ\text{R}) \end{array}$$

$$1212.7 \text{ ACFM} \times \left( \frac{19.7 \text{ PSIA}}{580^\circ\text{R}} \right) \times \left( \frac{530^\circ\text{R}}{14.7 \text{ PSIA}} \right) = 1485 \text{ SCFM}$$

**General Function Check****Tools Needed**

- Digital Multimeter (DMM)
- ST80/ST80L Configuration Software Application
- USB Cable Type B (male) to Type A (male); passive, straight-through type as supplied with instrument
- Small size flat blade screwdriver (for sensor wiring connection)

**Verifying Setup**

Connect the flow meter via USB to a computer or laptop running the ST80/ST80L configuration software supplied with the instrument. Refer to the ST80/ST80L Configuration Software manual **06EN003491** for details.

Confirm the setup of the flow meter by reviewing the setup windows in the configurator. Contact your local representative or FCI for instructions if a setup discrepancy exists.

**Checking NAMUR Fault Indication**

If the instrument's flow output is set up for NAMUR, check the output to see if it is driven to a NAMUR level. Refer to [NAMUR Setup](#), page 41 for NAMUR information. Refer to [Table 8](#) on page 42 for the list of faults that trigger NAMUR.

## Troubleshooting the Flow Element

### Check the Resistance of the Flow Element

Turn flow transmitter power OFF. Remove the TB1 connector plug from the sensor wiring pin socket (pull plug straight out).

Measure the resistance between the terminals of the pulled connector plug and compare with the values shown in [Table 27](#) below.

**Table 27 – Flow Element Resistance Measurements (In Ohms) Taken From Remote/Integral Electronics**

Term Number	TB1-1 (Htr Exc)	TB1-2 (Htr Rtn)	TB1-3 (Act Exc)	TB1-4 (Act Sen)	TB1-5 (Gnd Sen)	TB1-6 (Gnd)	TB1-7 (Ref Exc)	TB1-8 (Ref Sen)
TB1-1 (Htr Exc)	N/A	115 <sup>3</sup>	∞	∞	∞	∞	∞	∞
TB1-2 (Htr Rtn)	115 <sup>3</sup>	N/A	∞	∞	∞	∞	∞	∞
TB1-3 (Act Exc)	∞	∞	N/A	0 <sup>1</sup>	1080 <sup>2</sup>	1080 <sup>2</sup>	2160 <sup>2</sup>	2160 <sup>2</sup>
TB1-4 (Act Sen)	∞	∞	0 <sup>1</sup>	N/A	1080 <sup>2</sup>	1080 <sup>2</sup>	2160 <sup>2</sup>	2160 <sup>2</sup>
TB1-5 (Gnd Sen)	∞	∞	1080 <sup>2</sup>	1080 <sup>2</sup>	N/A	0 <sup>1</sup>	1080 <sup>2</sup>	1080 <sup>2</sup>
TB1-6 (Gnd)	∞	∞	1080 <sup>2</sup>	1080 <sup>2</sup>	0 <sup>1</sup>	N/A	1080 <sup>2</sup>	1080 <sup>2</sup>
TB1-7 (Ref Exc)	∞	∞	2160 <sup>2</sup>	2160 <sup>2</sup>	1080 <sup>2</sup>	1080 <sup>2</sup>	N/A	0 <sup>1</sup>
TB1-8 (Ref Sen)	∞	∞	2160 <sup>2</sup>	2160 <sup>2</sup>	1080 <sup>2</sup>	1080 <sup>2</sup>	0 <sup>1</sup>	N/A

- Notes: 1. Theoretical zero-ohm table values are influenced by sensor cable length, which typically adds <2 Ω.  
 2. Resistances are approximate for a sensor temperature of 70 °F (21 °C).  
 3. Heater resistance range is 108-120 Ω.

**Note:** There is added resistance to consider when measuring the flow element from the remote transmitter. The cable adds extra resistance. The added resistance can be found by measuring the ACT SEN wire to the ACT EXC wire (e.g., TB1-4 to TB1-3.).

**For Remote Units** – If the measured values do not match that shown in the above table, unplug the cabling connecting the local enclosure flow element to the remote transmitter and measure the resistance between the terminals of the flow element assembly terminal strip TS1. Compare the measured values with the values shown in [Table 28](#) below.

**Table 28 – Flow Element Resistance (In Ohms) at the Local Enclosure**

Term Number	1	2	3	4	5	6	7	8
1	N/A	0 <sup>1</sup>	1080 <sup>2</sup>	1080 <sup>2</sup>	1080 <sup>2</sup>	1080 <sup>2</sup>	∞	∞
2	0 <sup>1</sup>	N/A	1080 <sup>2</sup>	1080 <sup>2</sup>	1080 <sup>2</sup>	1080 <sup>2</sup>	∞	∞
3	1080 <sup>2</sup>	1080 <sup>2</sup>	N/A	2160 <sup>2</sup>	0 <sup>1</sup>	2160 <sup>2</sup>	∞	∞
4	1080 <sup>2</sup>	1080 <sup>2</sup>	2160 <sup>2</sup>	N/A	2160 <sup>2</sup>	0 <sup>1</sup>	∞	∞
5	1080 <sup>2</sup>	1080 <sup>2</sup>	0 <sup>1</sup>	2160 <sup>2</sup>	N/A	2160 <sup>2</sup>	∞	∞
6	1080 <sup>2</sup>	1080 <sup>2</sup>	2160 <sup>2</sup>	0 <sup>1</sup>	2160 <sup>2</sup>	N/A	∞	∞
7	∞	∞	∞	∞	∞	∞	N/A	115 <sup>3</sup>
8	∞	∞	∞	∞	∞	∞	115 <sup>3</sup>	N/A

- Notes: 1. Theoretical zero-ohm table values are influenced by sensor cable length, which typically adds <2 Ω.  
 2. Resistances are approximate for a sensor temperature of 70 °F (21 °C).  
 3. Heater resistance range is 108-120 Ω.

If the instrument has been on for some time, the resistance of the active RTD will be greater than the reference RTD.

If the instrument has been off for some time, the resistance of the active RTD will be the same as the reference RTD.

**For Remote Units** – If the measured resistances correspond to [Table 28](#), but not to [Table 27](#), then the sensor interconnect cable is probably defective. Replace the cable and recheck resistances. If the resistances are still off, contact Customer Service.

If the measured values do not correspond to [Table 27](#) or [Table 28](#) (for remote units), then the flow element is defective. Contact Customer Service.

Reinstall the sensor plug(s) and reattach the cables when troubleshooting is complete.

### Check the Heater

Use the configuration software to check the heater as follows (refer to the ST80/ST80L Configuration Software manual [06EN003491](#) for software details):

1. Access the **Heater Values** tab from the **Diagnostics** branch of the menu tree. See [Figure 54](#) below.
2. Click **Start Data Loop**. Note that the button changes color when clicked (light green to light orange).
3. Verify that the displayed values for *Heater Resistance*, *Heater Voltage*, and *Heater Current mA* are within normal parameters. Click **Stop Data Loop** when done. See [Table 29](#) below.

**Table 29 – Nominal Heater Parameter Ranges**

Heater Configuration	Resistance	Voltage	Current
AST™	108-120 Ω	4.32-12.6 V	40-105 mA
Constant Power	108-120 Ω	7.884-9.24 V	75 mA ±2 mA

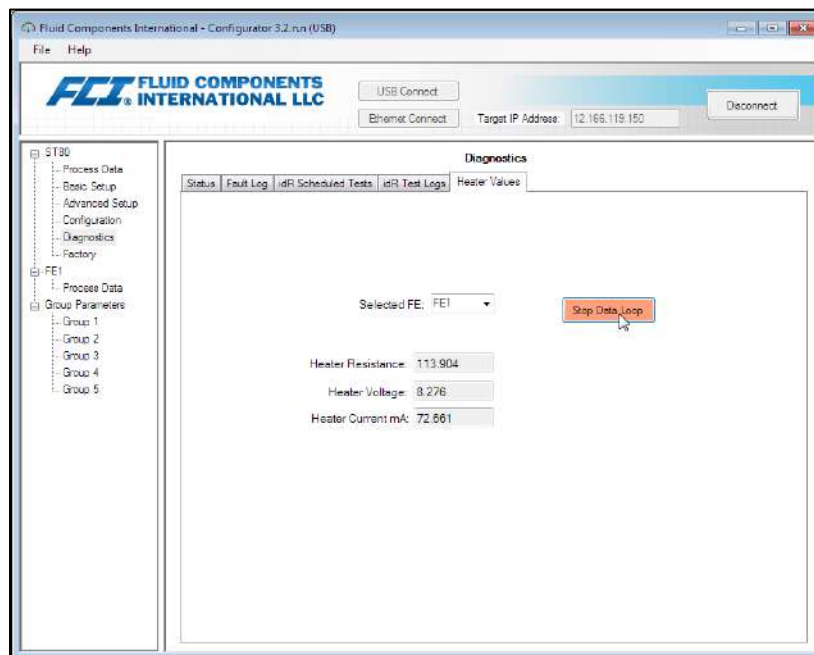

**Figure 54 – Example Heater Values Tab (Diagnostics)**

## Verification of the Electronics

**Warning:** **Explosion Hazard.** Do not disconnect equipment when flammable or combustible atmosphere is present. Operator assumes responsibility for all safety concerns relating to interrupting and reapplying power to their instrumentation.

**Note:** The information in this section applies to both AST™ and Constant Power configured instruments.

With instrument power ON remove the instrument's blind lid (see [Accessing the I/O Connectors](#), page 21). Check the green system status LED on the main board (see [Figure 55](#) below). The system status LED states are listed in the table below.

**Table 30 – System Status LED D3 States**

System Status LED (D3), State	Description
<b>Slow blink</b> (blink every 2 seconds)	Normal operation.
<b>OFF</b>	No power or power supply issue, or system controller halted (hang).
<b>ON</b> (no blink, continuous)	System controller halted (hang).

Cycle the power to see if the instrument recovers from a possible system controller hang. Contact FCI Technical Support for assistance if the system status LED is still not blinking.

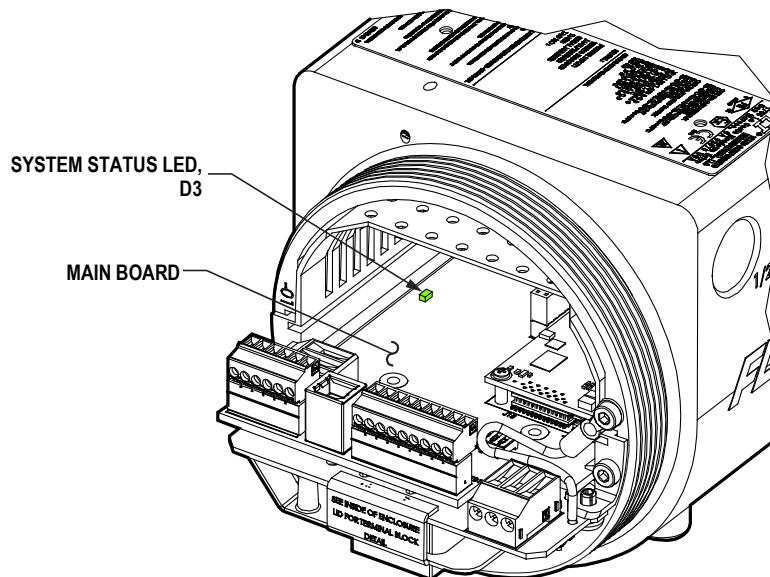

C01464-1-1

**Figure 55 – System Status LED, Main Board**

After checking the system status LED, verify the electronics with the three checks summarized below (there is no sequence in performing these checks).

- Transmitter Power Supply Check** via configuration software: *Factory|Sil Adj* tab (see [Transmitter Power Supply](#), below). Make sure that the displayed power supply voltages are within range.
- Heater Check** via configuration software: *Diagnostics|Heater Values* tab (see [Check the Heater](#), above). Make sure that the heater resistance, voltage, and current are within range.
- Internal Delta-R Resistor (idR) Check** via HMI display or configuration software: *Diagnostics/idR Scheduled Tests* tab (see [Internal Delta-R Resistor \(idR\) Check](#), page 43). After running the idR check, verify that the Low, Mid, and High range values show “Passed.”

**Note:** Should any of these checks fail, contact FCI Technical Support for assistance.

**Transmitter Power Supply**

Use the ST80/ST80L configuration software to check the power supply voltages. Refer to ST80/ST80L Configuration Software manual **06EN003491** for details. Select the *Factory* branch from the menu tree on the window's left side. Select the **SIL Adj** tab. The screen shows power supply voltage readings for +24 VDC and +5 VDC. Check that the displayed values are within range as listed in [Table 31](#) below.

**Table 31 – Instrument Power Supply Voltages**

<b>Power Supply Voltage</b>	<b>Acceptable Voltage Range</b>
Digital 5 VDC	+4.75 V to +5.25 V
Analog 24 VDC	+23.75 V to +24.25 V

If the voltage measurements are within the range shown in the table, the power supply is functioning properly.

## **Constant Power Configuration Troubleshooting**

### **Equipment List**

- 250  $\Omega$  0.01% resistor
- 2 digital multimeters (DMM)
- Delta R Calibration Data Sheet (serial number specific by instrument and group)
- FES-200 flow element simulator
- FES-200 interface cable for ST80/ST80L (022610-11)

*Alternative to FES-200:*

- 2 ea. Precision Decade Resistance Box, 0.1% (1 k $\Omega$  large step, 0.01  $\Omega$  small step)

### **Delta R Check for Constant Power Configured Units**

**Note:** If the flow meter's parameters have been changed, calibrations may be inaccurate or factory authorized changes have been made. Consult a factory service representative.

Each flow meter configured at the factory for *Constant Power* is provided with a Delta R data sheet that lists the differential resistance values that correlate to the flow meter's calibration. Resistance substitution instruments like the FES-200 can be used to check instrument calibration and verify correct operation of the flow transmitter using the Delta R data sheet.

To verify the transmitter is working properly, the sensor head must be disconnected and precision resistance (Delta R) values from the FES-200 are substituted. Then by measuring the transmitter output and display it can be determined whether the transmitter is still within factory specification.

### *Delta R Check*

1. Verify the Delta R data sheet has the same serial number and group number as the flow meter calibration that is being verified.
2. Turn transmitter power OFF.
3. Disconnect a flow element sensor from the ST80/ST80L transmitter (TB1) and connect the FES-200 cable connector in its place. See [Figure 57](#). Precision decade boxes can be used in place of the FES-200. See [Figure 58](#) for decade box wiring.
4. Connect a DMM to the transmitter 4-20 mA output by either method A or B as shown in [Figure 56](#) below.
  - a. To read 1 to 5 volts, disconnect both output loop wires and connect a precision 250

6. Verify the transmitter is in the calibration group matching the Delta R data sheet.
7. On the FES-200, dial in a Delta R value with the thumbwheel from the column marked Delta R (ohms) on the Delta R data sheet. Compare to the output value column (*VDC Across 250 Ohms* or *mA Output* as applicable) or the *Indicated Display* column or both. Verify that the meter reading is within the stated tolerance of the flow transmitter. See examples 1, 2 and 3 at the end of this section, as applicable.
8. Repeat for each point on the Delta R table, except for the step value and zero value.
9. Turn power OFF and disconnect the FES-200 and DMM. Reconnect the sensor element connector.
10. Close the enclosure, making sure none of the wires are strained. Ensure any seals and gaskets are properly installed.
11. Restore power to the meter.

If you are troubleshooting the flow meter and the readings are good, the flow transmitter is good and the problem may involve the flow element or interconnecting cable. If the readings are off, a flow element calibration may be required or the flow transmitter needs to be set up. Contact FCI Customer Service.

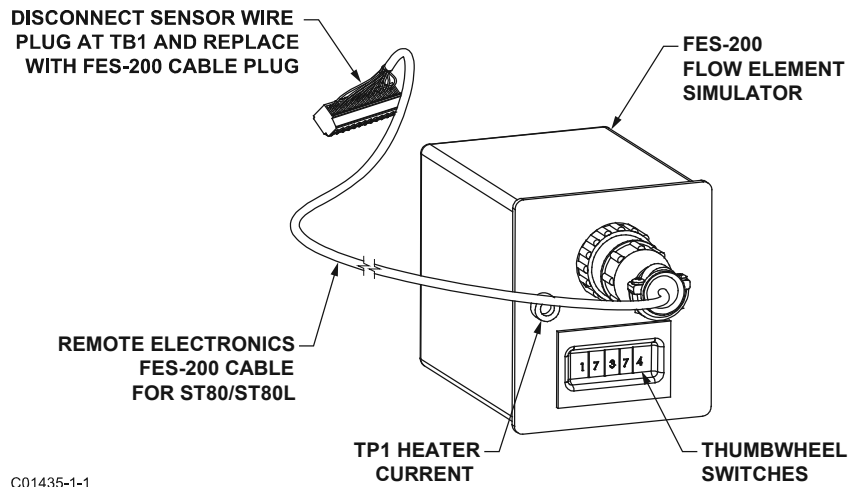

C01435-1-1

Figure 57 – Connecting FES-200 to ST80/ST80L Transmitter

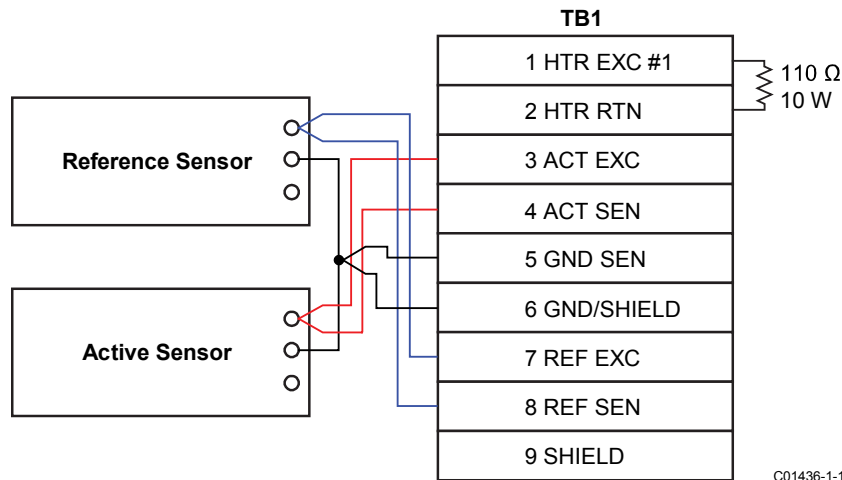

C01436-1-1

Figure 58 – ST80/ST80L Decade Box Wiring



*Allowable Limits*

Example 1 - 4-20 mA output check using 1-5 VDC measurement.

Accuracy:  $\pm(0.75\% \text{ reading} + 0.5\% \text{ full scale})$  from GF90 Manual

Example Delta R Table entry:

Delta R (ohms)	VDC Across 250 ohms	mA Output	Unit dR	Indicated Display
71.08	2.995	11.98	71.197	154.8 SCFM

- Measure VDC with FES-200 thumbwheel set to 071.08 = 3.011 VDC measured on DMM.
- Determine allowable VDC limits for the 2.995 VDC table value:

**Note:** Since the 1-5 VDC range starts at 1 VDC, account for this offset by subtracting 1 VDC from both the “reading” of 2.995 VDC and the “full scale” of 5 VDC.

- Allowable VDC limits =  $0.0075 \times (2.995 - 1) + 0.005 \times (5 - 1) = \pm 0.035$  VDC

**The measured value of 3.011 VDC is within the allowable limits of 2.995  $\pm$ 0.035 VDC.**

Example 2 - 4-20 mA output check (using example 1 sample data)

- Measure mA with FES-200 thumbwheel set to 071.08 = 12.04 mA measured on DMM.
- Determine allowable mA limits for the 11.98 mA table value:

**Note:** Since the 4-20 mA range starts at 4 mA, account for this offset by subtracting 4 mA from both the “reading” of 11.98 mA and the “full scale” of 20 mA.

- Allowable mA limits =  $0.0075 \times (11.98 - 4) + 0.005 \times (20 - 4) = \pm 0.139$  mA

**The measured value of 12.04 mA is within the allowable limits of 11.98  $\pm$ 0.139 mA.**

Example 3 - Indicated Display Check (using information from above examples)

- Record the indicated display value with FES-200 thumbwheel set to 071.08 = 156 SCFM indicated on display.
- Determine allowable limits for the 154.8 SCFM table value:

**Note:** The full scale display value is 310 SCFM in this example.

- Allowable Indicated flow limits =  $0.0075 \times 154.8 \text{ SCFM} + 0.005 \times 310 \text{ SCFM} = \pm 2.71$  SCFM

**The indicated value of 156 SCFM is within the allowable limits of 154.8  $\pm$ 2.71 SCFM.**

## **Defective Parts**

Before returning any equipment to FCI, obtain an RA number for authorization, tracking, and repair/replacement instructions. If a return is required, remove the defective part, replace with a spare, calibrate, then return defective part to FCI, freight prepaid, for disposition.

## **Customer Service**

1. In the event of problems or inquiries regarding the instrument, contact an authorized FCI field agent for the region or country. Refer to the FCI website: <http://www.fluidcomponents.com/> for a list of field service representatives (which includes phone and email contact information) and a list of service centers around the world.
2. Before contacting the FCI representative make sure that all the applicable information is near so that a more effective, efficient and timely response can be provided.
3. Refer to [APPENDIX E](#), page 143 for specific Customer Service policy provisions.

### Reference: Error/Status Register Information

Summarized below are various registers that provide the instrument with error/status information. This information is normally presented in the configuration software's *Fault Log* tab. Digital busses (such as HART) can also access this information via a read operation using the appropriate register address.

#### Instrument Fault Codes Tables

The basic CORE fault register (4 bytes) provides basic CORE and FE fault indication. Detailed faults are given in the 6-byte detailed CORE fault register and the 4-byte FE fault register. The latter two registers provide specific error status for a fault indicated by the basic CORE fault register.

**Table 32 – Basic CORE Fault Register (CORE CY Command)**

Octet-Bit	Fault Name	Fault Description	Fault Type	Hex Bit Map
0-0	FE_01_FAULT	FE1 is reporting a fault or an error	Fatal/Non-Fatal	0x00000001
0-1	FE_02_FAULT	FE2 is reporting a fault or an error (ST100A)	Fatal/Non-Fatal	0x00000002
0-2 to 0-7	FCI Reserved (Not Used)			0x00000004 to 0x00000080
1-1 to 1-8	FCI Reserved (Not Used)			0x00000100 to 0x00008000
2-0	PD_FATAL_FAULT	At least one FE has a fatal error or fault	Fatal	0x00010000
2-1	FCI Reserved (Not Used)			0x00020000
2-2	PD_NON_OP	At least one FE was non-operational (self-test)	Non-Fatal	0x00040000
2-3	PD_SYSTEM_ERROR	System (Core) error	Non-Fatal	0x00080000
2-4	FCI Reserved (Not Used)			0x00100000
2-5	PD_NO_PD_UPDATE	All FEs reported a fatal error	Fatal	0x00200000
2-6	PD_SD_CARD_ERROR	SD Card error	Non-Fatal	0x00400000
2-7	FCI Reserved (Not Used)			0x00800000
3-0 to 3-1	FCI Reserved (Not Used)			0x01000000 to 0x02000000
3-2	Process Alarm #1		Non-Fatal	0x04000000
3-3	Process Alarm #2		Non-Fatal	0x08000000
3-4	Process Alarm #3		Non-Fatal	0x10000000
3-5	Process Alarm #4		Non-Fatal	0x20000000
3-6	Process Alarm #5		Non-Fatal	0x40000000
3-7	Process Alarm #6		Non-Fatal	0x80000000

Note: 1. *Fault Type* reflects factory default programming. The Fatal/Non-Fatal designation is programmable via the Configurator software's **Core Faults** tab (*Factory* branch menu tree – requires entry of appropriate level password).

Table 33 – Detailed CORE Fault Register (CORE 2V Command)

Octet-Bit	Status Description	Fault Type	Hex Bit Map
0-0	Device Error: If any of these errors occurs: I2C error, UART error, Mutex error, watchdog reset	Fatal	0x000000000001
0-1	FCI Reserved (Not Used)	Non-Fatal	0x000000000002
0-2	FCI Reserved (Not Used)	Non-Fatal	0x000000000004
0-3	CORE unable to update process data (PD_NO_FE_DATA). Unable to obtain/use data from any Active FEs	Fatal	0x000000000008
0-4	FCI Reserved (Not Used)	Non-Fatal	0x000000000010
0-5	CORE detects FRAM/SPI error	Fatal	0x000000000020
0-6	CORE reports SD card error. Either initialization (corrupt card) error, or card became full (error while writing). For ST100A only.	Non-Fatal	0x000000000040
0-7	FCI Reserved (Not Used)	Non-Fatal	0x000000000080
1-0	FCI Reserved (Not Used)	Non-Fatal	0x000000000100
1-1	FCI Reserved (Not Used)	Non-Fatal	0x000000000200
1-2	FCI Reserved (Not Used)	Non-Fatal	0x000000000400
1-3	FCI Reserved (Not Used)	Non-Fatal	0x000000000800
1-4	FCI Reserved (Not Used)	Non-Fatal	0x000000001000
1-5	CORE unable to communicate with one or more FEs (PD_COMM_ERROR)	Fatal	0x000000002000
1-6	FCI Reserved (Not Used)	Non-Fatal	0x000000004000
1-7	CORE: averaged flow out of range of "Flow Min" or "Flow Max"	Non-Fatal	0x000000008000
2-0	FCI Reserved (Not Used)	Non-Fatal	0x000000010000
2-1	FCI Reserved (Not Used)	Non-Fatal	0x000000020000
2-2	FCI Reserved (Not Used)	Non-Fatal	0x000000040000
2-3	CORE: averaged temperature above "Temperature Max"	Fatal	0x000000080000
2-4	CORE: averaged temperature below "Temperature Min"	Fatal	0x000000100000
2-5	FE Heater is shorted or below operating limit.	Fatal	0x000000200000
2-6	FE Heater monitoring ADC fails to respond.	Fatal	0x000000400000
2-7	FE Heater is open or above operating limit.	Fatal	0x000000800000
3-0	The Reference-R ADC converter fails to respond.	Fatal	0x000001000000
3-1	FCI Reserved (Not Used)	Non-Fatal	0x000002000000
3-2	The Reference-R ADC's count number is below the minimum.	Non-Fatal	0x000004000000
3-3	FCI Reserved (Not Used)	Non-Fatal	0x000008000000
3-4	Process flow is above the maximum limit.	Non-Fatal	0x000010000000
3-5	FCI Reserved (Not Used)	Non-Fatal	0x000020000000
3-6	FCI Reserved (Not Used)	Non-Fatal	0x000040000000
3-7	The ADC for monitoring the temperature inside the unit fails to respond.	Non-Fatal	0x000080000000
4-0	The Delta-R ADC fails to respond.	Fatal	0x000100000000
4-1	ST80: Not used. ST100A: 4-20mA Input / Pressure Input ADC fails to respond.	Non-Fatal	0x000200000000
4-2	Reference-R value is above operating limit.	Non-Fatal	0x000400000000
4-3	The Inter-Integrated Circuit channel 0 bus fails to communicate.	Non-Fatal	0x000800000000
4-4	The ADC for monitoring heater's conditions fails to respond.	Fatal	0x001000000000
4-5	The port expansion integrated chip fails to respond.	Non-Fatal	0x002000000000
4-6	FCI Reserved (Not Used)	Non-Fatal	0x004000000000
4-7	FCI Reserved (Not Used)	Non-Fatal	0x008000000000
5-0	The FRAM of the Flow Element fails to respond.	Non-Fatal	0x010000000000
5-1	The Active excitation current Integrated Circuit (IC) fails.	Non-Fatal	0x020000000000
5-2	The Reference excitation current Integrated Circuit (IC) fails.	Non-Fatal	0x040000000000
5-3	CORE: process data are not updated because (all) FE's are in self-test mode, or the system is in non-operating mode.	Non-Fatal	0x080000000000
5-4	Reference-R value is below operating limit.	Non-Fatal	0x100000000000
5-5	Delta-R value is above operating limit.	Non-Fatal	0x200000000000
5-6	Delta-R value is below operating limit.	Non-Fatal	0x400000000000
5-7	The unit is performing a (diagnostic) test.	Non-Fatal	0x800000000000

Notes: 1. *Fault Type* reflects factory default programming. The Fatal/Non-Fatal designation is programmable via the Configurator software's **FE Faults** tab (*Factory* branch menu tree – requires entry of appropriate level password).

Table 34 – FE Fault Register (FE DF Command)

Octet-Bit	Fault Name	Fault Description	Fault Type <sup>1</sup>	Hex Bit Map
0-0	FCI Reserved (Not Used)	—	—	0x00000001
0-1	FCI Reserved (Not Used)	—	—	0x00000002
0-2	HTR_CURR_ADC_OVER_RANGE_FAULT	The heater current analog-to-digital converter shows saturation at its input.	Fatal	0x00000004
0-3	FCI Reserved (Not Used)	—	—	0x00000008
0-4	FCI Reserved (Not Used)	—	—	0x00000010
0-5	FCI Reserved (Not Used)	—	—	0x00000020
0-6	SENSOR_ABOVE_MAX_FLOW_FAULT	Process flow is above the maximum limit.	Fatal	0x00000040
0-7	SENSOR_OVER_TEMP_FAULT	Process temperature is above the maximum limit.	Fatal	0x00000080
1-0	SENSOR_UNDER_TEMP_FAULT	Process temperature is below the minimum limit.	Fatal	0x00000100
1-1	HEATER_SHORTED_FAULT	The heater is shorted or its value is below the normal operating value.	Fatal	0x00000200
1-2	HEATER_OPEN_FAULT	The heater is open or its value is above the normal operating value.	Fatal	0x00000400
1-3	HTR_CURR_ADC_FAULT	The heater current analog-to-digital converter (ADC) fails to respond.	Non-Fatal	0x00000800
1-4	dR_ADC_FAULT	The Delta-R ADC fails to respond.	Fatal	0x00001000
1-5	REF_ADC_FAULT	The Reference-R ADC converter fails to respond.	Fatal	0x00002000
1-6	BRD_TEMP_LIMITS_FAULT	Temperature inside the unit is outside the limits (above or below the operating limits).	Fatal	0x00004000
1-7	I2C0_FAULT	The Inter-Integrated Circuit (I2C) channel 0 bus fails to communicate.	Fatal	0x00008000
2-0	SENSOR_BELOW_MIN_ADC_FAULT	The Reference-R ADC's count number is below the minimum.	Fatal	0x00010000
2-2	FCI Reserved (Not Used)	—	—	0x00020000
2-2	PORT_EXPANDER_FAULT	The port expansion integrated chip fails to respond.	Non-Fatal	0x00040000
2-3	BELOW_dR_MIN_FAULT	Delta-R value is below minimum limit.	Fatal	0x00080000
2-4	TMP100_ADC_FAULT	The ADC for monitoring the temperature inside the unit fails to respond.	Non-Fatal	0x00100000
2-5	LTC2654_DAC_FAULT	The digital-to-analog converter fails to respond.	Non-Fatal	0x00200000
2-6	FE_FRAM_FAULT	The FRAM of the Flow Element fails to respond.	Non-Fatal	0x00400000
2-7	FCI Reserved (Not Used)	—	—	0x00800000
3-0	HTRS_MON_ADC_FAULT	The ADC for monitoring heater's conditions fails to respond.	Non-Fatal	0x01000000
3-1	ACT_EXC_CURR_FAULT	The Active excitation current Integrated Circuit (IC) fails.	Non-Fatal	0x02000000
3-2	REF_EXC_CURR_FAULT	The Reference excitation current Integrated Circuit (IC) fails.	Non-Fatal	0x04000000
3-3	SENSOR_REFR_ABOVE_ABS_MAX	Reference-R value is above operating limit.	Fatal	0x08000000
3-4	SENSOR_REFR_BELOW_ABS_MIN	Reference-R value is below operating limit.	Non-Fatal	0x10000000
3-5	SENSOR_DR_ABOVE_ABS_MAX	Delta-R value is above operating limit.	Non-Fatal	0x20000000
3-6	SENSOR_DR_BELOW_ABS_MIN	Delta-R value is below operating limit.	Fatal	0x40000000
3-7	FE_AUTO_CHECK	The unit is performing a (diagnostic) test.	Fatal	0x80000000

Notes: 1. *Fault Type* reflects factory default programming. The Fatal/Non-Fatal designation is programmable via the Configurator software's **FE Faults** tab (Factory branch menu tree – requires entry of appropriate level password).

## APPENDIX A      DRAWINGS

This appendix contains ST80/ST80L technical drawings. [Table 35](#) below summarizes the drawings.

**Table 35 – ST80/ST80L Drawings in Appendix A**

Dwg. No.	Dwg. Type	Page No.	Description
C01547-1	System	<a href="#">95</a>	ST80 Integral System Layout
C01548-1	System	<a href="#">96</a>	ST80L Integral System Layout
C01549-1	System	<a href="#">97</a>	Remote System Layout
C01550-1	System	<a href="#">98</a>	ST80 Process Connection Options
C01551-1	System	<a href="#">99</a>	ST80L Spool Piece/Process Connection Options
C01552-1	System	<a href="#">100</a>	“F/FP” and “FPC” Style Sensor Head Detail
C01553-1	System	<a href="#">101</a>	“S” Style Sensor Head Detail
C01554-1	System	<a href="#">102</a>	Wet Gas MASSter (Moisture Shield) Sensor Head Detail
C01555-1	System	<a href="#">103</a>	ST80 Series Local Enclosure Options
C01556-1	System	<a href="#">104</a>	ST80 Series Alternative Local Enclosure Option
C01557-1	System	<a href="#">105</a>	ST80 Series Electronics Enclosure
C01558-1	System	<a href="#">106</a>	ST80 Series Electronics Assembly, Standard
C01559-1	System	<a href="#">107</a>	ST80 Series Electronics Assembly, with PROFIBUS-DP Option
C01560-1	Wiring Diagram	<a href="#">108</a>	ST80 Series Wiring Diagram, Standard
C01561-1	Wiring Diagram	<a href="#">109</a>	ST80 Series Wiring Diagram, with PROFIBUS-DP Option
026155	Wiring Diagram	<a href="#">110</a>	Wiring Diagram, Remote, ST80 Series
026763	Wiring Diagram	<a href="#">112</a>	Wiring Diagram, Integral, ST80 Series
004871	Outline Instl.	<a href="#">114</a>	Transmitter, ST100/ST100A/ST80, Compression Fitting, Hazardous Location, Integral
004872	Outline Instl.	<a href="#">115</a>	Transmitter, ST100 & ST102A/ST100A & ST102AA/ST80, Compression Fitting, Hazardous Location, Remote
004852	Outline Instl.	<a href="#">116</a>	Transmitter, ST100 & ST102A/ST100A & ST102AA/ST80, 1¼-inch NPT PGL, Hazardous Location, Remote
004857	Outline Instl.	<a href="#">117</a>	Transmitter, ST100/ST100A/ST80 1¼-inch NPT PGL, Hazardous Location, Integral
004877	Outline Instl.	<a href="#">118</a>	Transmitter, ST100 & ST102A/ST100A & ST102AA/ST80, 1¼-inch NPT PGM, Hazardous Location, Remote
004934	Outline Instl.	<a href="#">119</a>	Transmitter, ST100L/ST100AL/ST80L, Inline 1-inch Tubing, ¾-inch MNPT Explosion Proof, Integral
004873	Outline Instl.	<a href="#">120</a>	Transmitter, ST100L/ST100AL/ST80L, Inline Pipe Spool, Explosion Proof, Local
004874	Outline Instl.	<a href="#">121</a>	Transmitter, ST100L/ST100AL/ST80L, Inline Pipe Spool, Explosion Proof, Remote
004891	Outline Instl.	<a href="#">122</a>	Transmitter, ST100/ST100A/ST80 1-inch NPT, Hazardous Location, Integral
004893	Outline Instl.	<a href="#">123</a>	Transmitter, ST100/ST100A/ST80 Flanged, Hazardous Location, Integral

This Page Intentionally Left Blank

C01547-1-1

**ST80 INTEGRAL SYSTEM LAYOUT**

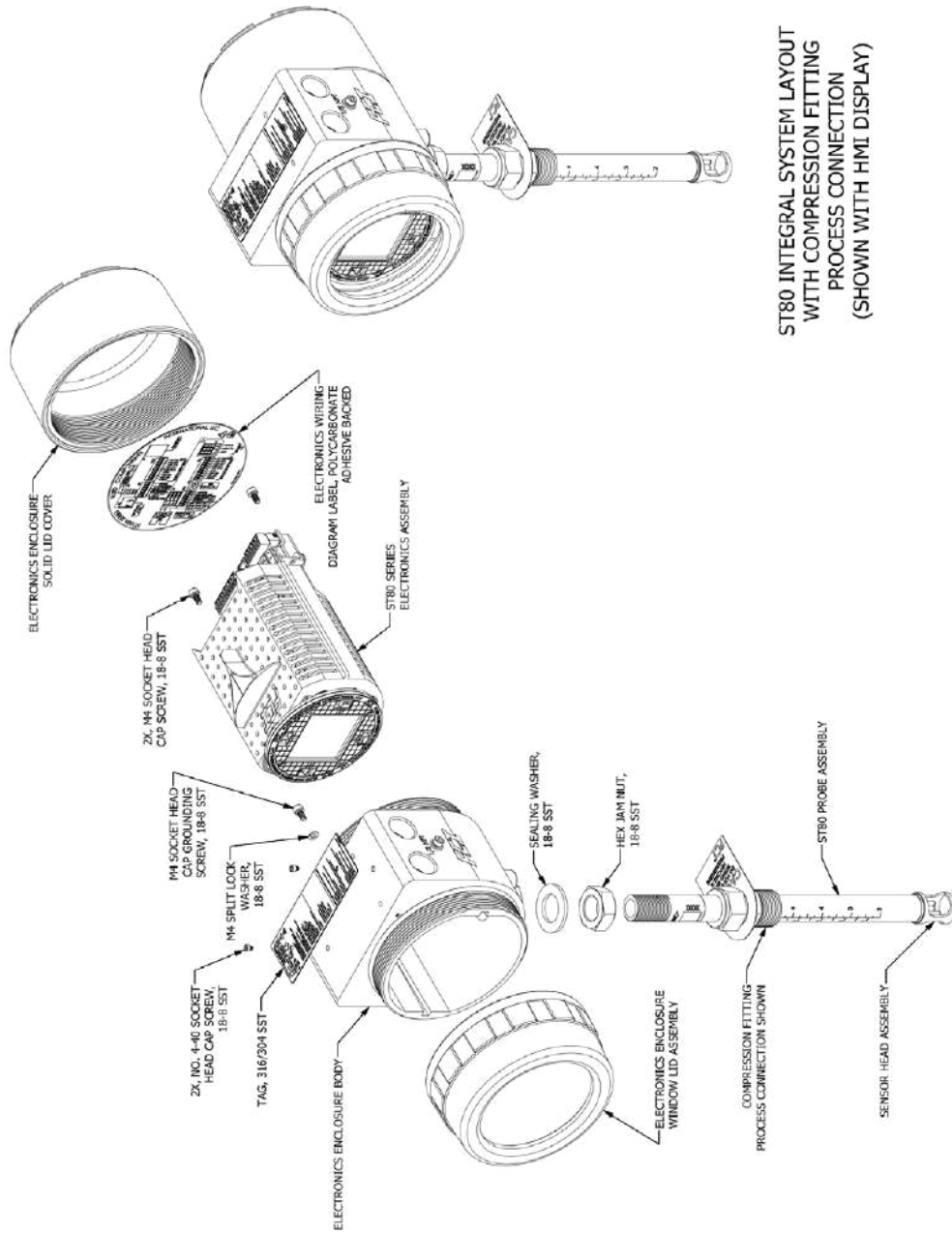

**ST80 INTEGRAL SYSTEM LAYOUT WITH COMPRESSION FITTING PROCESS CONNECTION (SHOWN WITH HMI DISPLAY)**

**ST80L INTEGRAL INLINE SYSTEM LAYOUT**

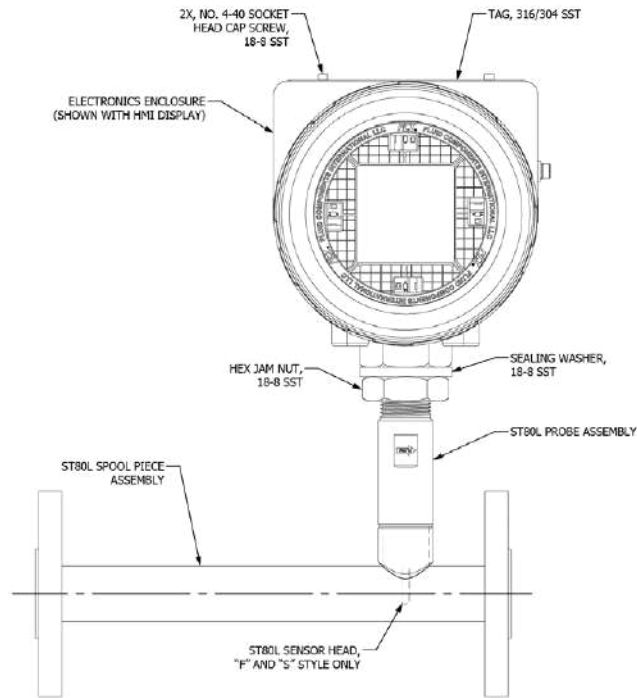

**ST80L INTEGRAL INLINE SYSTEM LAYOUT  
WITH FLANGED PROCESS CONNECTION  
(SHOWN WITH HMI DISPLAY)**

C01548-1-1



**REMOTE SYSTEM LAYOUT**  
(ST80 PACKING GLAND FLOW ELEMENT SHOWN, SETUP TYPICAL FOR ALL REMOTE UNITS)

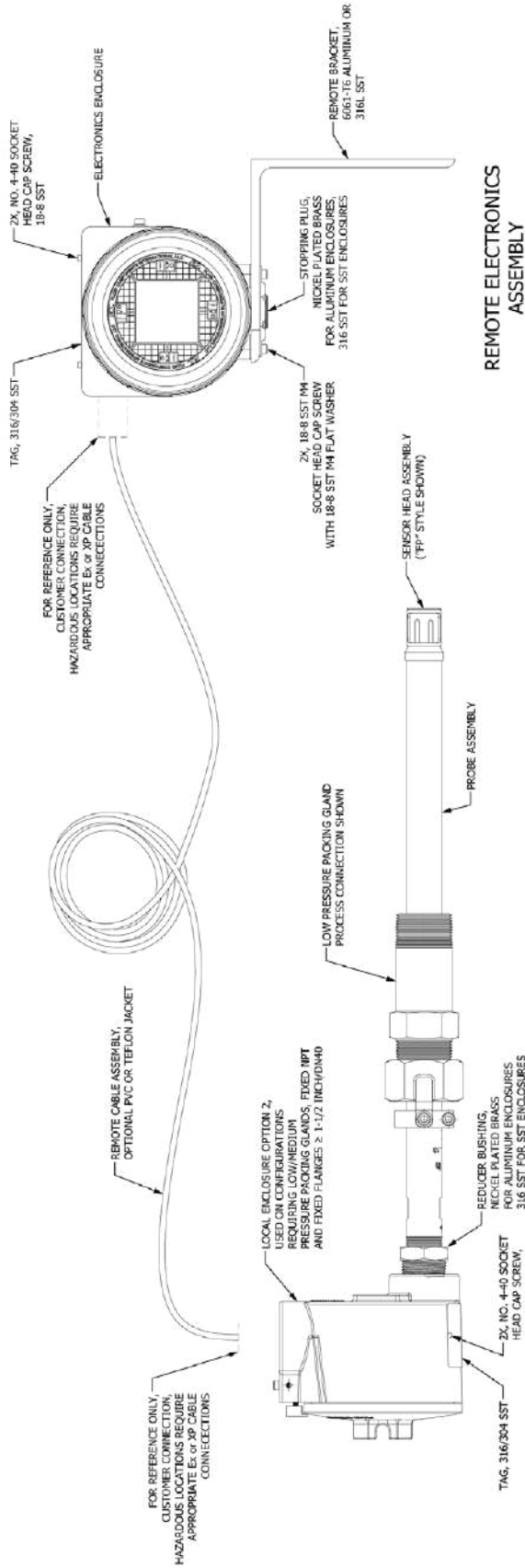

**LOCAL FLOW ELEMENT ASSEMBLY**

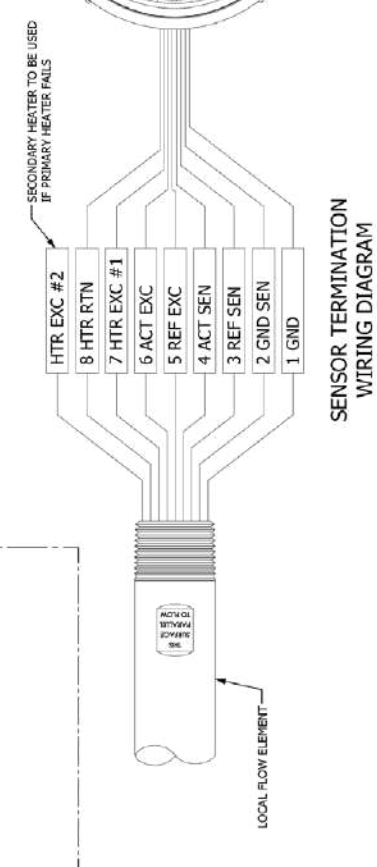
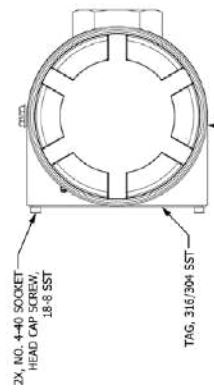

C01549-1-1

**ST80 PROCESS CONNECTION OPTIONS**  
(LOCAL FLOW ELEMENT OF REMOTE CONFIGURATIONS SHOWN)

**NOTES:**  
1. UNLESS OTHERWISE SPECIFIED DIMENSIONS ARE IN INCHES. DIMENSIONS IN BRACKETS ARE IN MILLIMETERS.

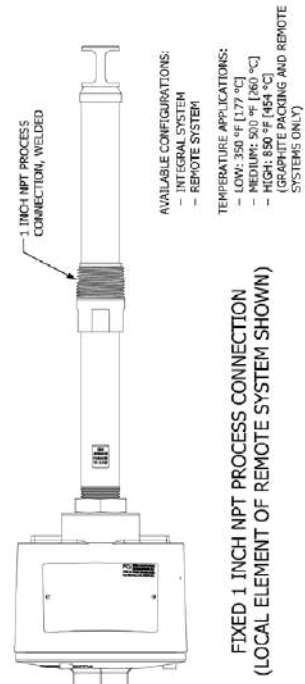
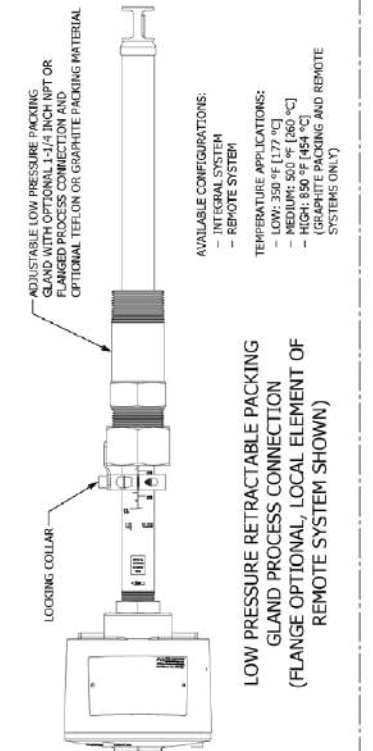
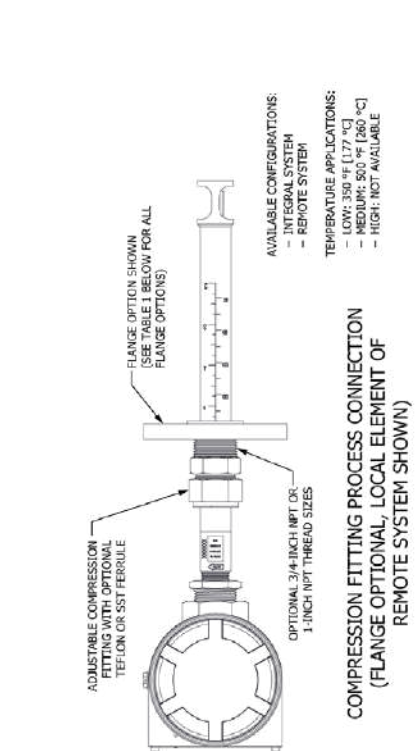
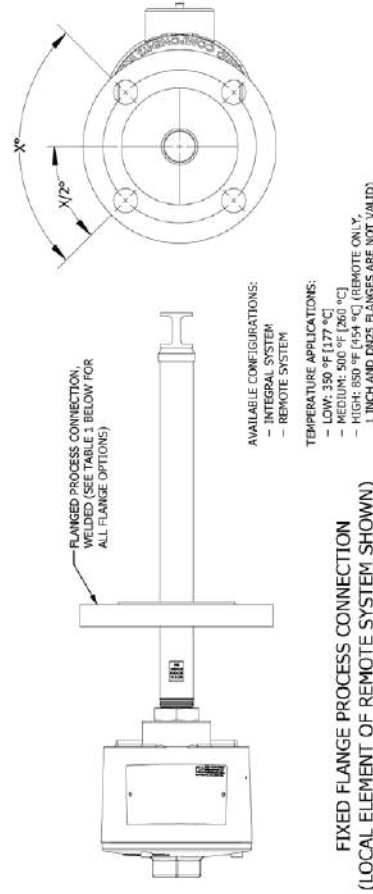
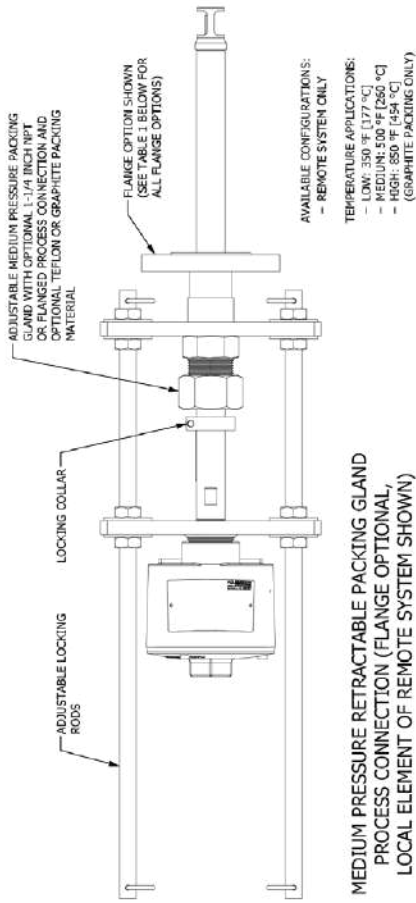

TABLE 1. ST80 FLANGE OPTIONS

FLANGE TYPE/SIZE	RATING	MATERIAL
ANSI 1 INCH	150 LB	-CARBON STEEL
	300 LB	-316L SST
ANSI 1-1/2 INCH	150 LB	-CARBON STEEL
	300 LB	-316L SST
ANSI 2 INCH	150 LB	-CARBON STEEL
	300 LB	-316L SST
DIN DN25	PN40	
DIN DN40	PN15	
DIN DN50	PN40	

NOTE: CARBON STEEL FLANGES ARE ONLY AVAILABLE WITH 316L SST FLOW ELEMENT TYPES.

**ST80L SPOOL PIECE/PROCESS CONNECTION OPTIONS**

**NOTES:**  
 1. UNLESS OTHERWISE SPECIFIED DIMENSIONS ARE IN INCHES.  
 DIMENSIONS IN BRACKETETS ARE IN (MILLIMETERS).

TABLE 1. ST80L SPOOL PIECE CONFIGURATIONS

PIPE TYPE	WALL THICKNESS/ PIPE SCHEDULE	PROCESS CONNECTIONS	MATERIAL	"A" LENGTH
1" TUBE	.065" [1.7] WALL		316L SST	9" [229]
1" PIPE	SCH 40	- MALE NPT - FEMALE NPT - FLANGED	- 316L SST - HASTELLOY C276	13.5" [343]
1-1/2" PIPE	SCH 80	- BUTT WELD		18" [457]
2" PIPE	SCH 40			

NOTE: WITH 1" TUBING, NPT CONNECTIONS MUST BE 3/4" AND FLANGED CONNECTIONS MUST BE 3/4" OR 1" SIZES. ALL OTHER CONNECTIONS MUST BE 1" INCH TUBING ONLY. VORTABS AVAILABLE FOR ALL SPOOL PIECES.

TABLE 2. ST80L FLANGE OPTIONS

FLANGE TYPE/SIZE	RATING	MATERIAL
ANSI 3/4 INCH	150 LB	316L SST
ANSI 1 INCH	150 LB	
	300 LB	
ANSI 1-1/2 INCH	150 LB	- CARBON STEEL - 316L SST - HASTELLOY C
	300 LB	
ANSI 2 INCH	150 LB	
	300 LB	
DIN DN25	PN40	
DIN DN40	PN15	
DIN DN50	PN40	316L SST

NOTE: CARBON STEEL FLANGES ARE ONLY AVAILABLE WITH 316L SST SPOOL BODY TYPES.

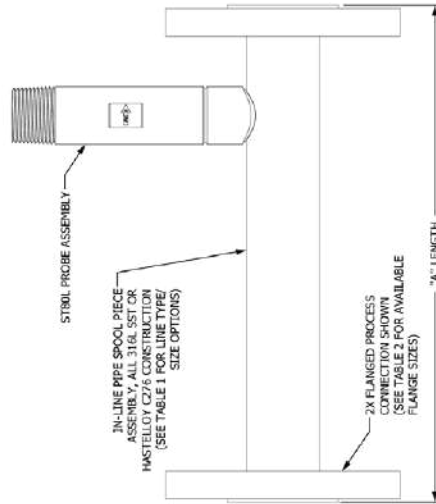

**IN-LINE PIPE ASSEMBLY WITH FLANGED PROCESS CONNECTION**

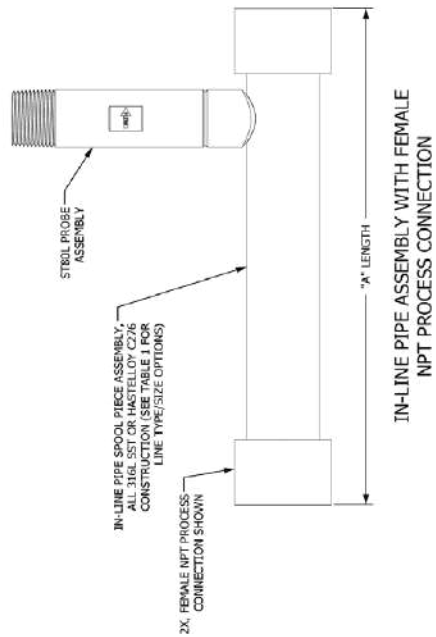

**IN-LINE PIPE ASSEMBLY WITH FEMALE NPT PROCESS CONNECTION**

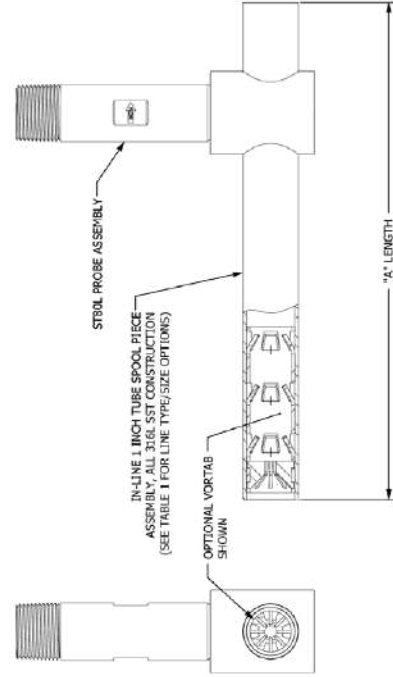

**IN-LINE TUBE ASSEMBLY WITH BUTT WELD PROCESS CONNECTION AND VORTAB FLOW CONDITIONER**

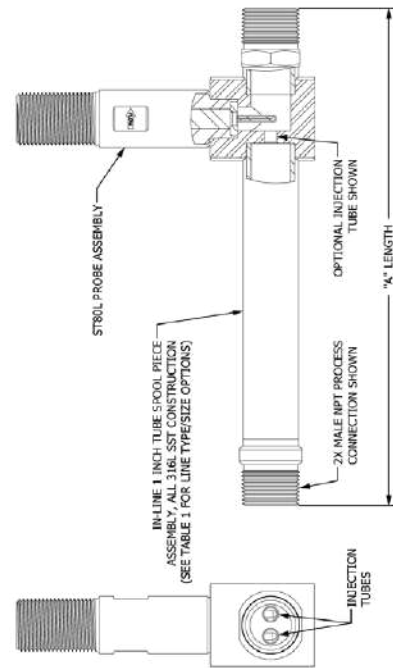

**IN-LINE TUBE ASSEMBLY WITH MALE NPT PROCESS CONNECTION AND INJECTION TUBE**

C01551-1-1

**"F/FP" AND "FPC" STYLE SENSOR HEAD DETAIL**

**NOTES:**  
 1. "F" HEAD IS SIMILAR TO THE "FP" HEAD EXCEPT WITHOUT THE SENSOR PROTECTOR.

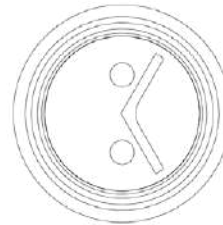
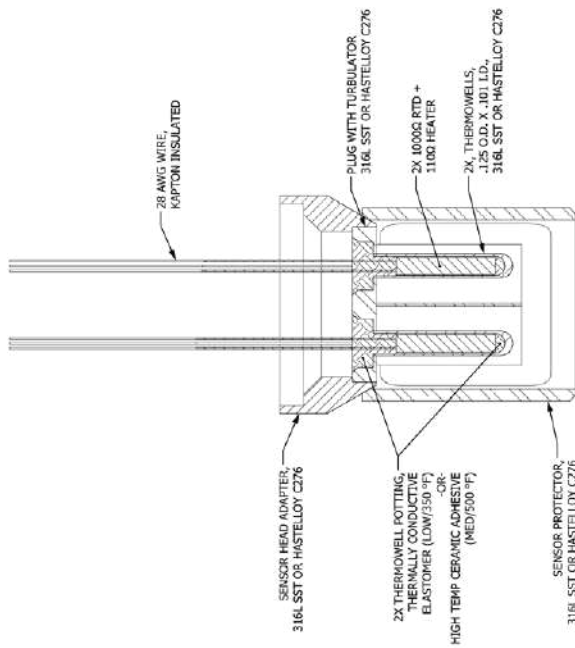

LOW/MED TEMP "FP" AND "FPC" SENSOR HEAD ("FPC" STYLE HEAD SHOWN)

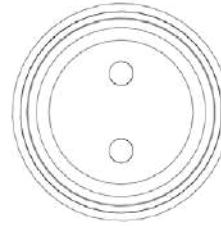
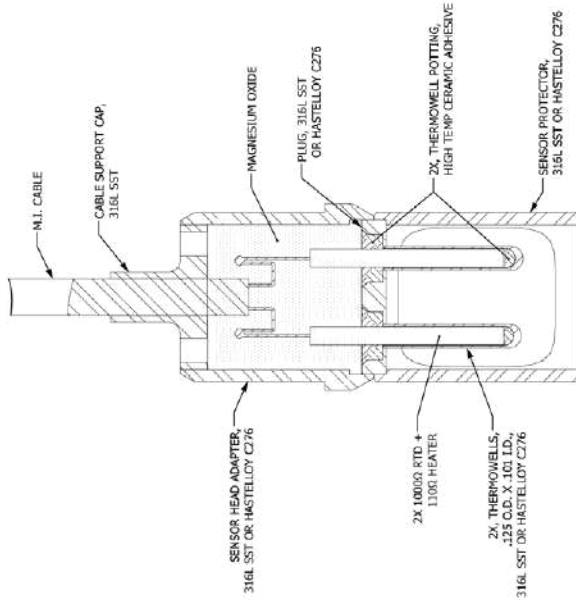

HIGH TEMP "FP" AND "FPC" SENSOR HEAD ("FP" STYLE HEAD SHOWN)

**"S" STYLE SENSOR HEAD DETAIL**

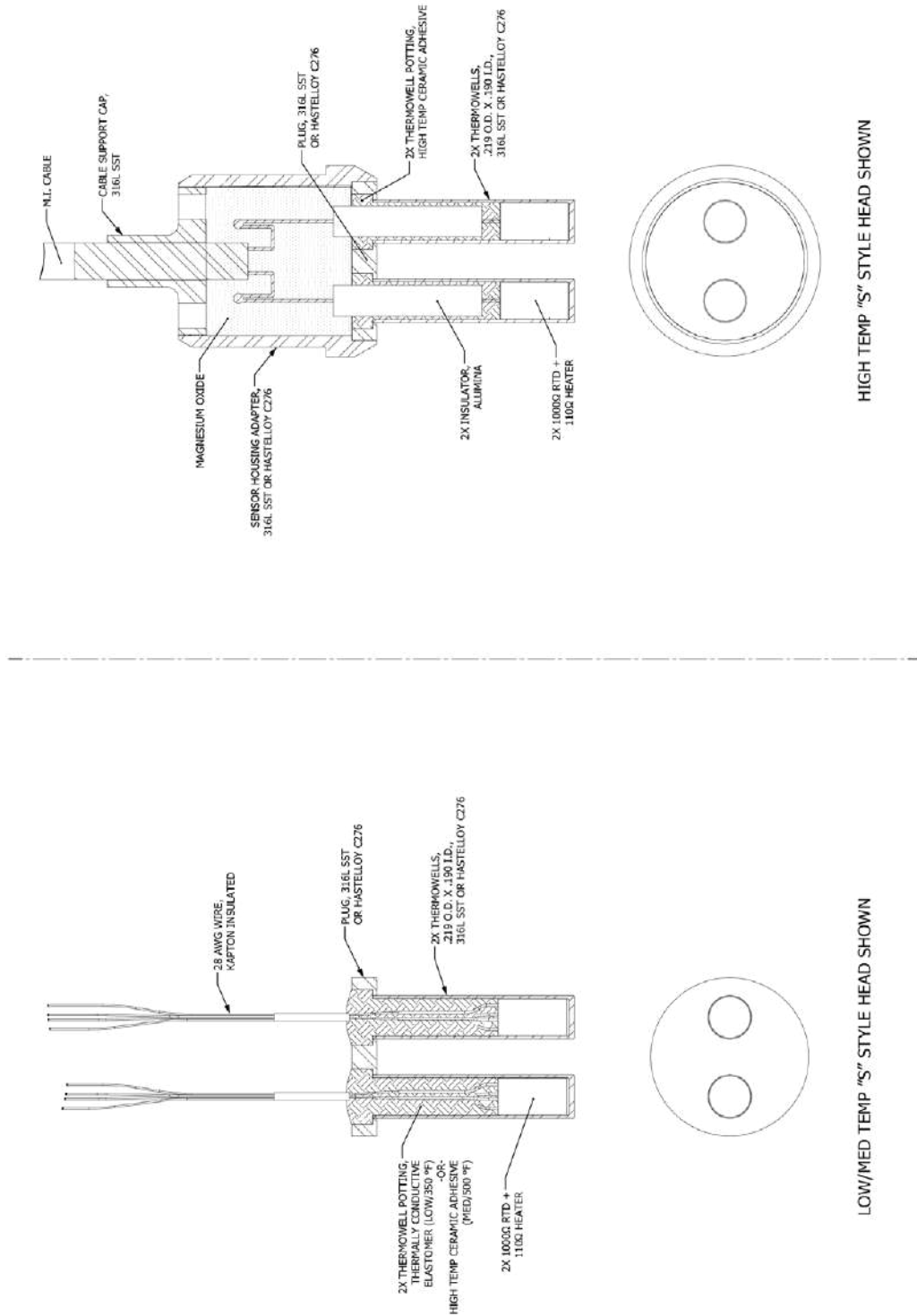

C01553-1-1

**WET GAS MASSTER (MOISTURE SHIELD) SENSOR HEAD DETAIL**  
 (AVAILABLE FOR LOW TEMPERATURES [≤350 °F] ONLY)

- NOTES:**
1. MOISTURE SHIELD AVAILABLE WITH THE FOLLOWING CONFIGURATIONS:
    - COMPRESSION FITTINGS
    - LOW AND MEDIUM PRESSURE PACKING GLANDS

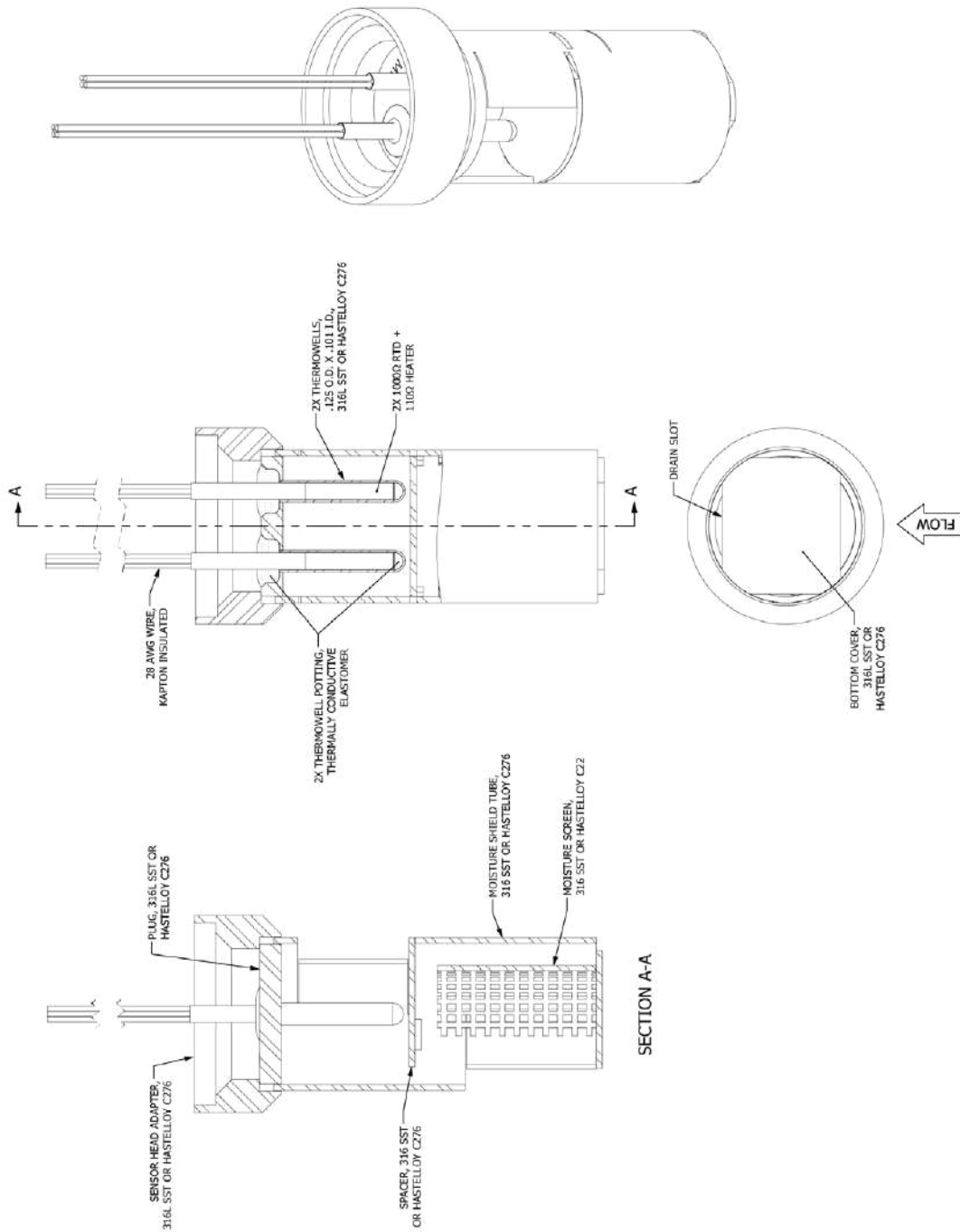

**ST80 SERIES LOCAL ENCLOSURE OPTIONS**

**NOTES:**  
1. DIMENSIONS IN BRACKETS ARE IN [MILLIMETERS].

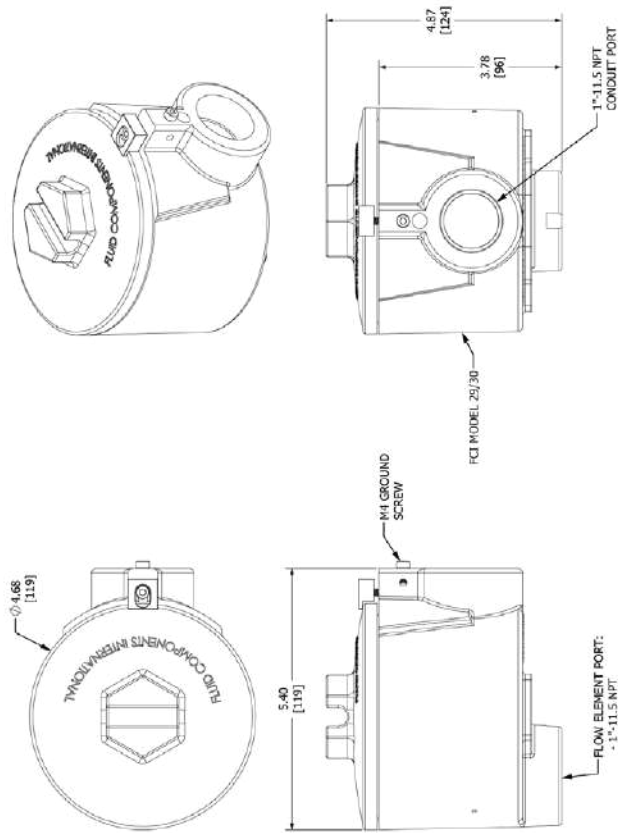

**ENCLOSURE RATING:**  
**FM:**  
XP CLASS I, DIV I, GROUPS B, C, D,  
DIP CLASS II, III, DIV I, GROUPS E, F, G,  
TYPE 4X, IP66/IP67.  
**ATEX:**  
II 2 G Ex db IIC Gb; IP66/IP67  
II 2 D Ex tb IIIC Db; IP66/IP67  
**IECEx:**  
Ex db IIC Gb; IP66/IP67  
Ex tb IIIC Db; IP66/IP67

**NOTES:**  
1. CONNECTION WIRING MUST BE RATED TO ≥80 °C AT ENCLOSURE ENTRY POINTS.  
2. ENCLOSURE MATERIAL:  
- ALUMINUM ALLOY A356.0-T6, A360 OR ADC12  
- SST PER ASTM A743 CF8M  
3. O-RING MATERIAL: VITON/FLUOROCARBON (-31 °F [-35 °C] TO 437 °F [225 °C]) OR BUINA/NITRILE (-40 °F [-40 °C] TO 257 °F [125 °C])  
4. USED ON ALL ST80 REMOTE CONFIGURATIONS REQUIRING A LOW/MEDIUM PRESSURE PACKING GLAND, FIXED NPT, 2.1-1/2 INCH ANSI FLANGE, OR 2 DIN40 FLANGE PROCESS CONNECTION.  
5. FREE INTERNAL VOLUME: 36 CUBIC INCHES [990 CUBIC CM]

LOCAL ENCLOSURE OPTION 2  
(ALUMINUM AND STAINLESS STEEL)

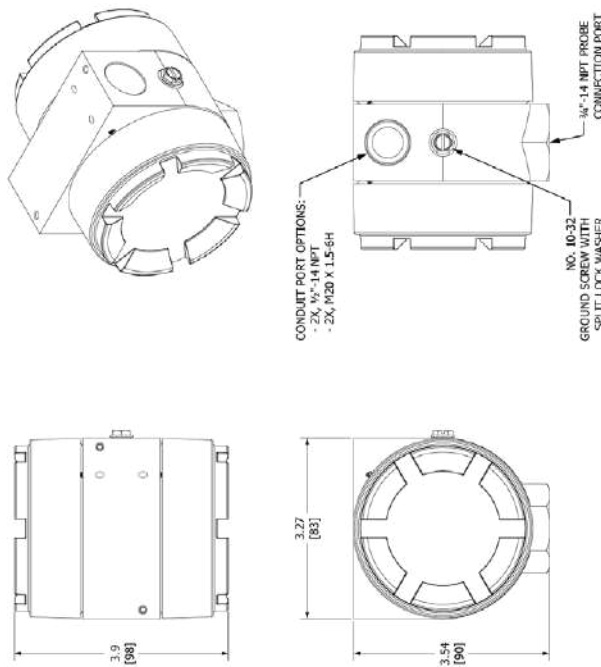

**ENCLOSURE RATING:**  
**FM:**  
XP CLASS I, DIV I, GROUPS B, C, D,  
DIP CLASS II, III, DIV I, GROUPS E, F, G,  
Ta = 60 °C,  
TYPE 4X, IP66.  
**ATEX:**  
II 2 G Ex db IIC Gb; IP66/IP67  
II 2 D Ex tb IIIC Db  
**IECEx:**  
Ex db IIC Gb; IP66/IP67  
Ex tb IIIC Db

**NOTES:**  
1. CONNECTION WIRING MUST BE RATED TO ≥80 °C AT ENCLOSURE ENTRY POINTS.  
2. ENCLOSURE MATERIAL:  
- ALUMINUM ADC10 OR ADC12  
- SST PER ASTM A743 CF8M OR ASTM A743 CF8M  
3. O-RING MATERIAL: NITRILE (-30 °F [-34 °C] TO 400 °F [204 °C]) OR VITON (-15 °F [-26 °C] TO 400 °F [204 °C])  
4. USED ON ALL ST80 REMOTE CONFIGURATIONS AS WELL AS ALL ST80 REMOTE CONFIGURATIONS REQUIRING A COMPRESSION FITTING, 1-INCH ANSI FLANGE, OR DIN25 FLANGE PROCESS CONNECTION.  
5. FREE INTERNAL VOLUME: 16 CUBIC INCHES [262 CUBIC CM]

LOCAL ENCLOSURE OPTION 1  
(ALUMINUM AND STAINLESS STEEL)

C01555-1-1

**ST80 SERIES ALTERNATIVE LOCAL ENCLOSURE OPTION**

**NOTES:**  
1. DIMENSIONS IN BRACKETS ARE IN (MILLIMETERS).

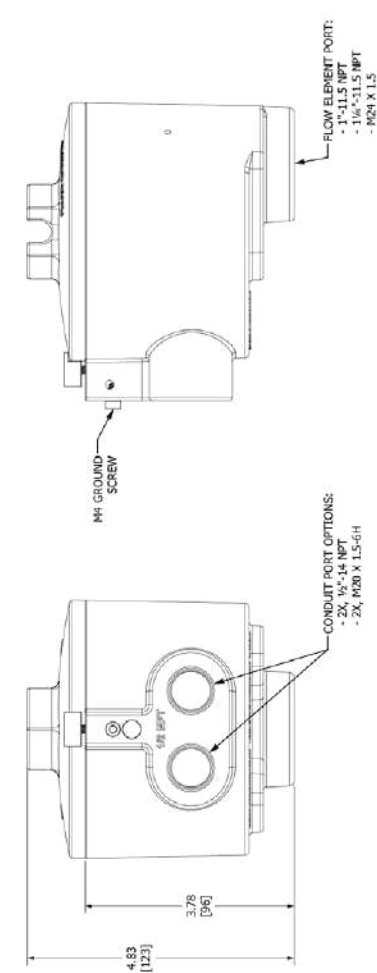
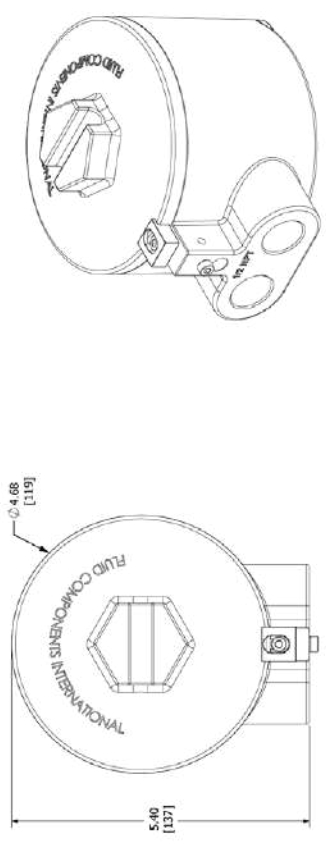

**ENCLOSURE RATING:**  
**FMI:**  
XP CLASS I, DIV 1, GROUPS B, C, D,  
DIP CLASS II, III, DIV 1, GROUPS E, F, G,  
TYPE 4X, IP66/IP67.  
**ATEX:**  
II 2 G Ex db IIC Gb; IP66/IP67  
II 2 D Ex tb IIIC Db; IP66/IP67  
**IECEK:**  
Ex db IIC Gb; IP66/IP67  
Ex tb IIIC Db; IP66/IP67

- NOTES:**
1. CONNECTION WIRING MUST BE RATED TO 280 °C
  2. ENCLOSURE ENTRY POINTS.
  3. O-RING MATERIAL: VITON/FLUOROCARBON (-31 °F [-35 °C] TO 437 °F [225 °C]) OR BUNA-N/NITRILE (-40 °F [-40 °C] TO 257 °F [125 °C])
  4. ALTERNATIVE LOCAL ENCLOSURE THAT CAN BE USED ON ALL ST80 REMOTE CONFIGURATIONS REQUIRING A LOW/MEDIUM PRESSURE PACKING GLAND, FIXED NPT, 2-1/2 INCH ANSI FLANGE, OR 2\"/>



**ST80 SERIES ELECTRONICS ENCLOSURE**

**NOTES:**  
1. DIMENSIONS IN BRACKETS ARE IN (MILLIMETERS).

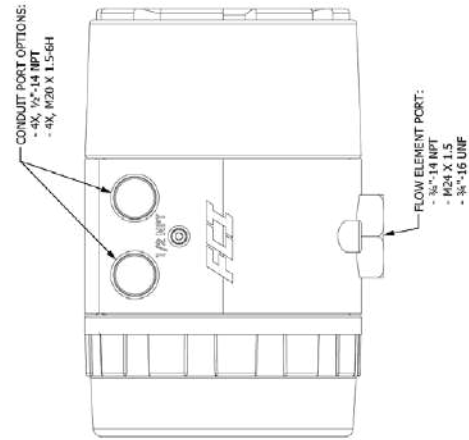
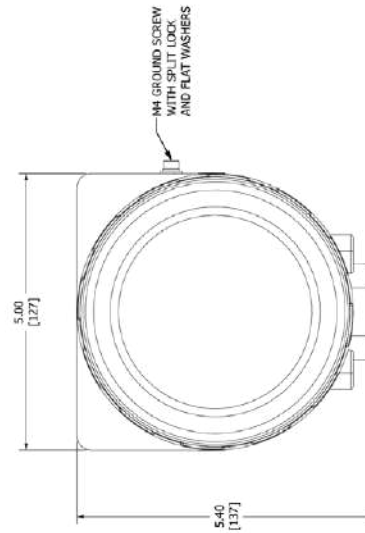
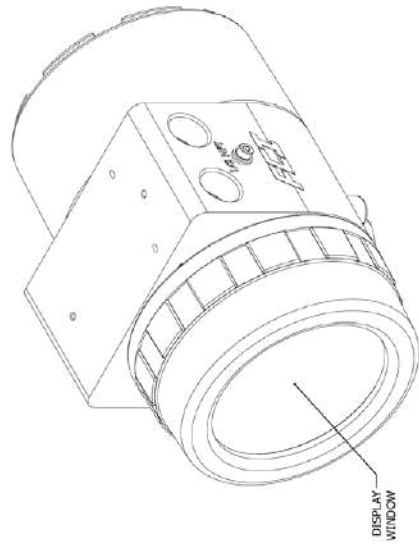
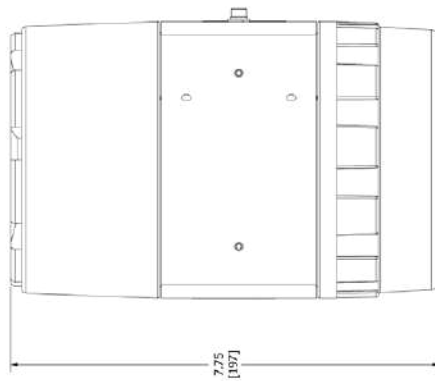

**ENCLOSURE RATING:**  
**FM:**  
XP CLASS I, DIV I, GROUPS E, C, D,  
DIP CLASS II, III, DIV I, GROUPS E, F, G,  
TYPE 4X, IP67.  
**ATEX:**  
II 2 G Ex db IIC Gb; IP67  
II 2 D Ex tb IIIC Db; IP67  
**IECEX:**  
Ex db IIC Gb; IP67  
Ex tb IIIC Db

- NOTES:**
1. CONNECTION WIRING MUST BE RATED TO 380 °C AT ENCLOSURE ENTRY POINTS.
  2. ENCLOSURE MATERIAL:  
- ALUMINIUM ALLOY ETAC #6000 OR ALUMINIUM ALLOY 360
  3. O-RING MATERIAL: COPOLYMER NITRILE (-30 °F (-34 °C) TO 250 °F (131 °C))  
OR SILICONE (-40 °F (-40 °C) TO 300 °F (149 °C))  
OR PTFE (-200 °F (-129 °C) TO 300 °F (149 °C))
  4. WINDOW MATERIAL: THERMOPLASTIC POLYURETHANE CLASS CLEAR
  5. WINDOW SEALING MATERIAL: LOCTITE E-LOK/EP HYXOL EPOXY
  6. CURE TIME/TEMPERATURE: 24 HOURS AT 77 °F (25 °C)
  7. FREE INTERNAL VOLUME: 96 CUBIC INCHES (1.573 CUBIC CM)

**ST80 SERIES ELECTRONICS ASSEMBLY, STANDARD**

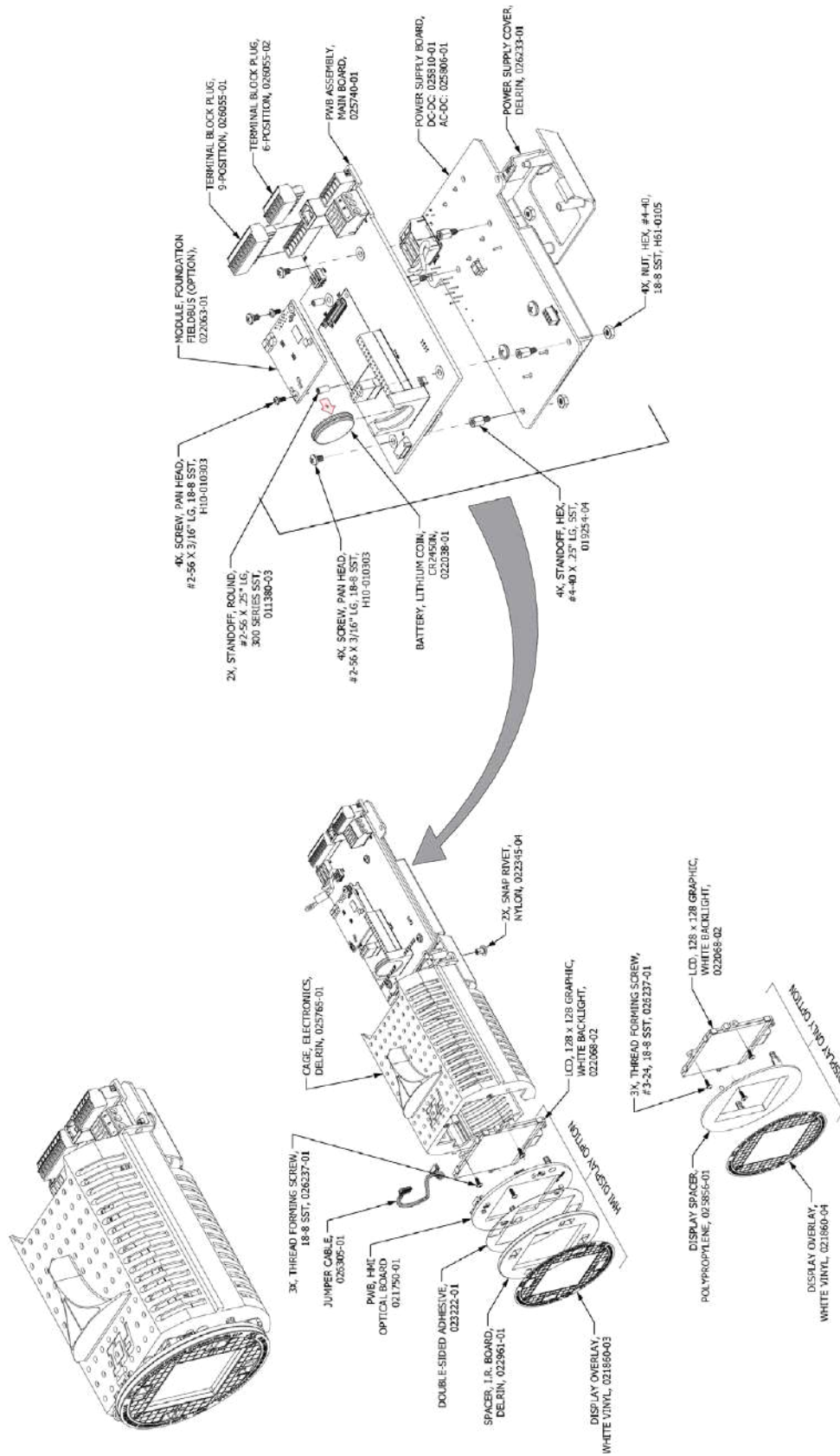

C01558-1-1

ST80 SERIES ELECTRONICS ASSEMBLY, WITH PROFIBUS-DP OPTION

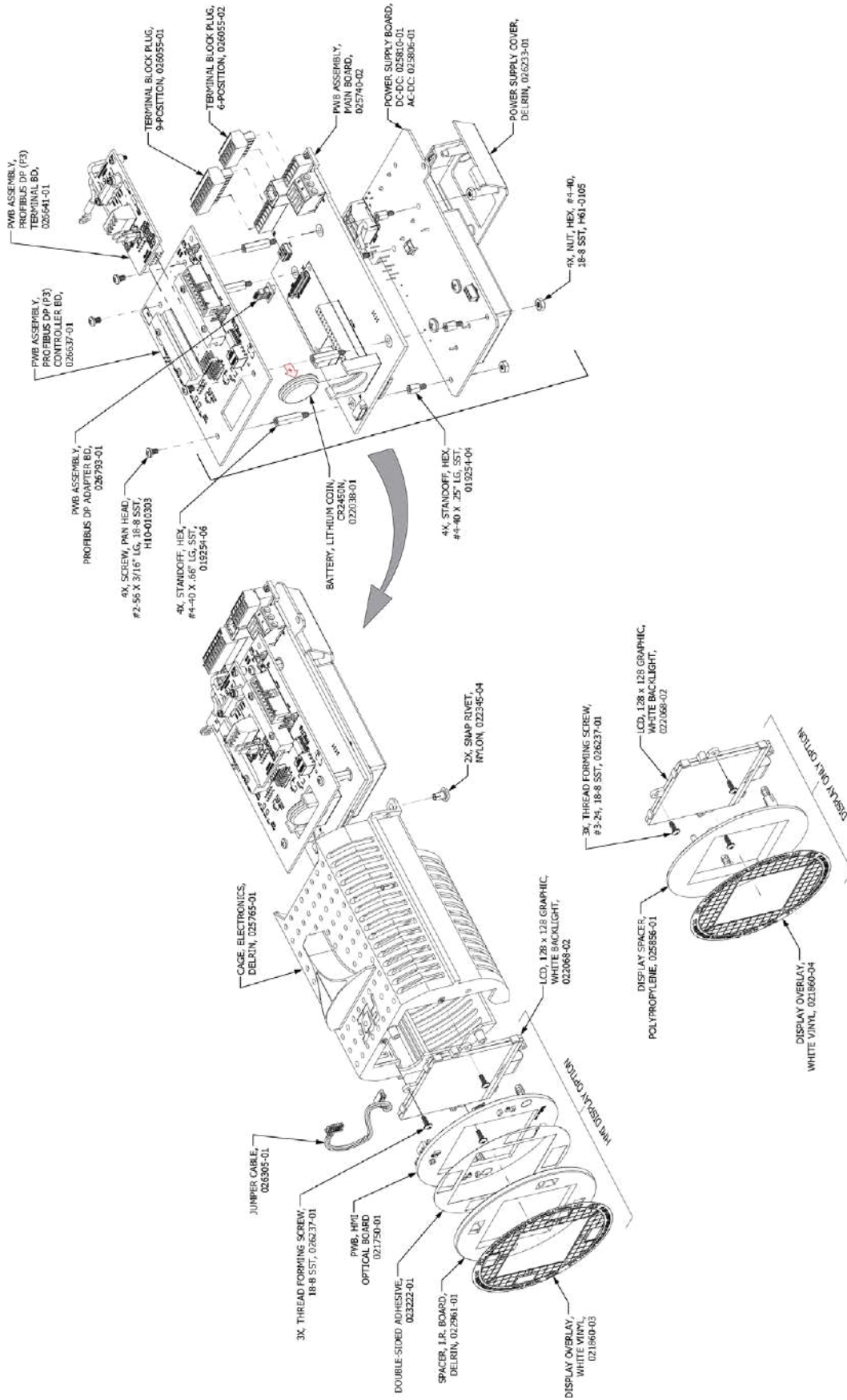

C01559-1-1

ST80 SERIES WIRING DIAGRAM, STANDARD

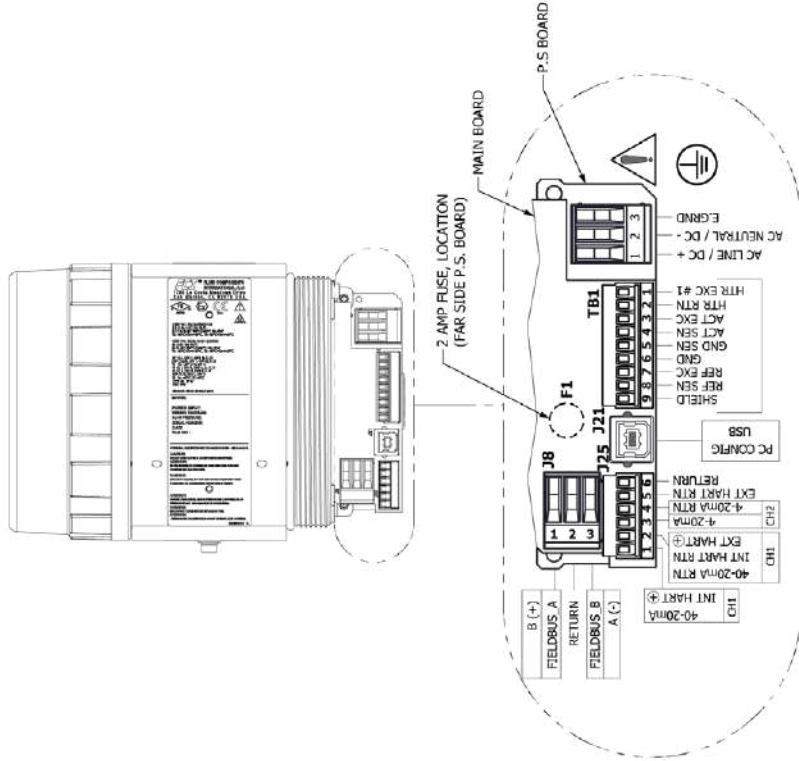

TABLE 1 – J25 CONNECTOR 16-28 AWG (MAIN BOARD)

PIN NO.	PIN LABEL	4-20mA / HART OUTPUT WIRING CONNECTIONS	
		ANALOG OUTPUT 4-20mA	HART OUTPUT
1	4-20 mA INT HART (+)	CH1	CH1 (INTERNAL) CH1 (EXTERNAL)
2	4-20 mA RTN	*	*
3	4-20 mA EXT HART (+)	*	*
4	4-20 mA RTN	*	*
5	4-20 mA EXT HART RTN	*	*
6	RETURN	*	*

TABLE 2 – J8 CONNECTOR 12-24 AWG (MAIN BOARD)

PIN NO.	MODBUS FOUNDATION FIELDBUS / PROFIBUS	PIN LABEL	DC POWER 19.2-28.8 Vdc		
			AC LINE	DC +	DC -
1	B (+)	FIELDBUS_A			
2	RETURN	RETURN			
3	A (-)	FIELDBUS_B			

TABLE 3 – P1 CONNECTOR 12-24 AWG (P.S. BOARD)

PIN NO.	MODBUS FOUNDATION FIELDBUS / PROFIBUS	PIN LABEL	DC POWER 19.2-28.8 Vdc		
			AC LINE	DC +	DC -
1	B (+)	FIELDBUS_A			
2	RETURN	RETURN			
3	A (-)	FIELDBUS_B			

TABLE 4 – INSTRUMENT WIRING RECOMMENDED AWG

CONNECTION	10 FT	50 FT	100 FT	250 FT	500 FT	1000 FT
POWER AC OR DC	22	22	22	20	18	16
INTERCONNECTING SHIELDED SIGNAL CABLE	24	24	24	22	22	18
ANALOG OUT (HART)	16-28	16-28	16-28	16-28	16-28	16-28
DIGITAL OUT (FOUNDATION FIELDBUS)	FF-844-H1 (14-24 AWG)					
MODBUS	RS485 (14-24 AWG)					

**ST80 SERIES WIRING DIAGRAM, WITH PROFIBUS-DP OPTION**

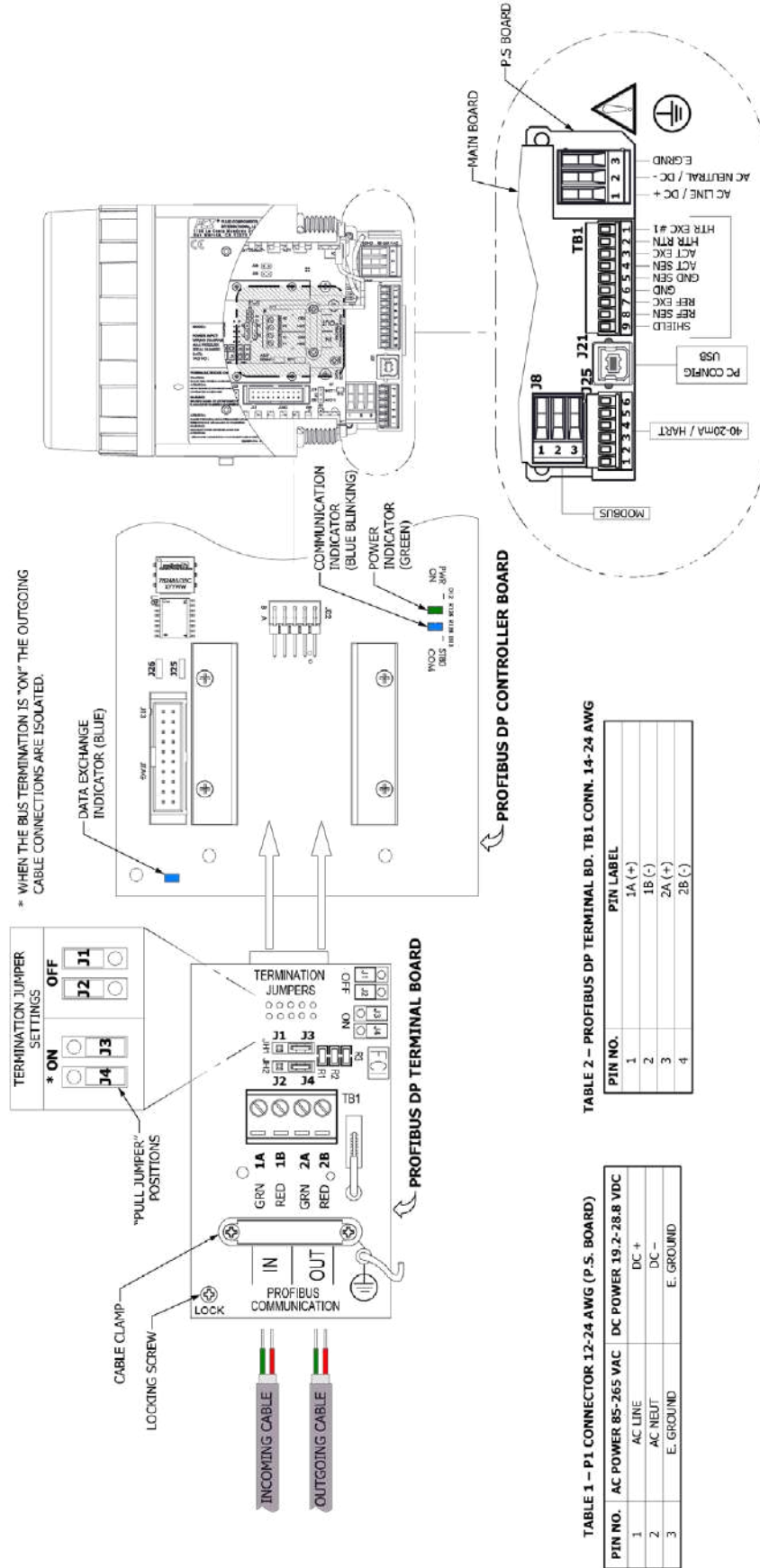

**TABLE 1 – P1 CONNECTOR 12-24 AWG (P.S. BOARD)**

PIN NO.	AC POWER 85-265 VAC	DC POWER 19.2-28.8 VDC
1	AC LINE	DC +
2	AC NEUT	DC -
3	E. GROUND	E. GROUND

**TABLE 2 – PROFIBUS DP TERMINAL BD. TB1 CONN. 14-24 AWG**

PIN NO.	PIN LABEL
1	1A (+)
2	1B (-)
3	2A (+)
4	2B (-)

**TABLE 3 – INSTRUMENT WIRING RECOMMENDED AWG**

CONNECTION	10 FT	50 FT	100 FT	250 FT	500 FT	1000 FT
POWER, AC OR DC	22	22	20	18	16	16
INTERCONNECTING SHIELDED SIGNAL CABLE	24	24	22	22	18	18
ANALOG OUT (HART)	16-28	16-28	16-28	16-28	16-28	16-28
DIGITAL IN/OUT (PROFIBUS)	RS485 (14-24 AWG)					
MODBUS	RS485 (14-24 AWG)					

C01561-1-1

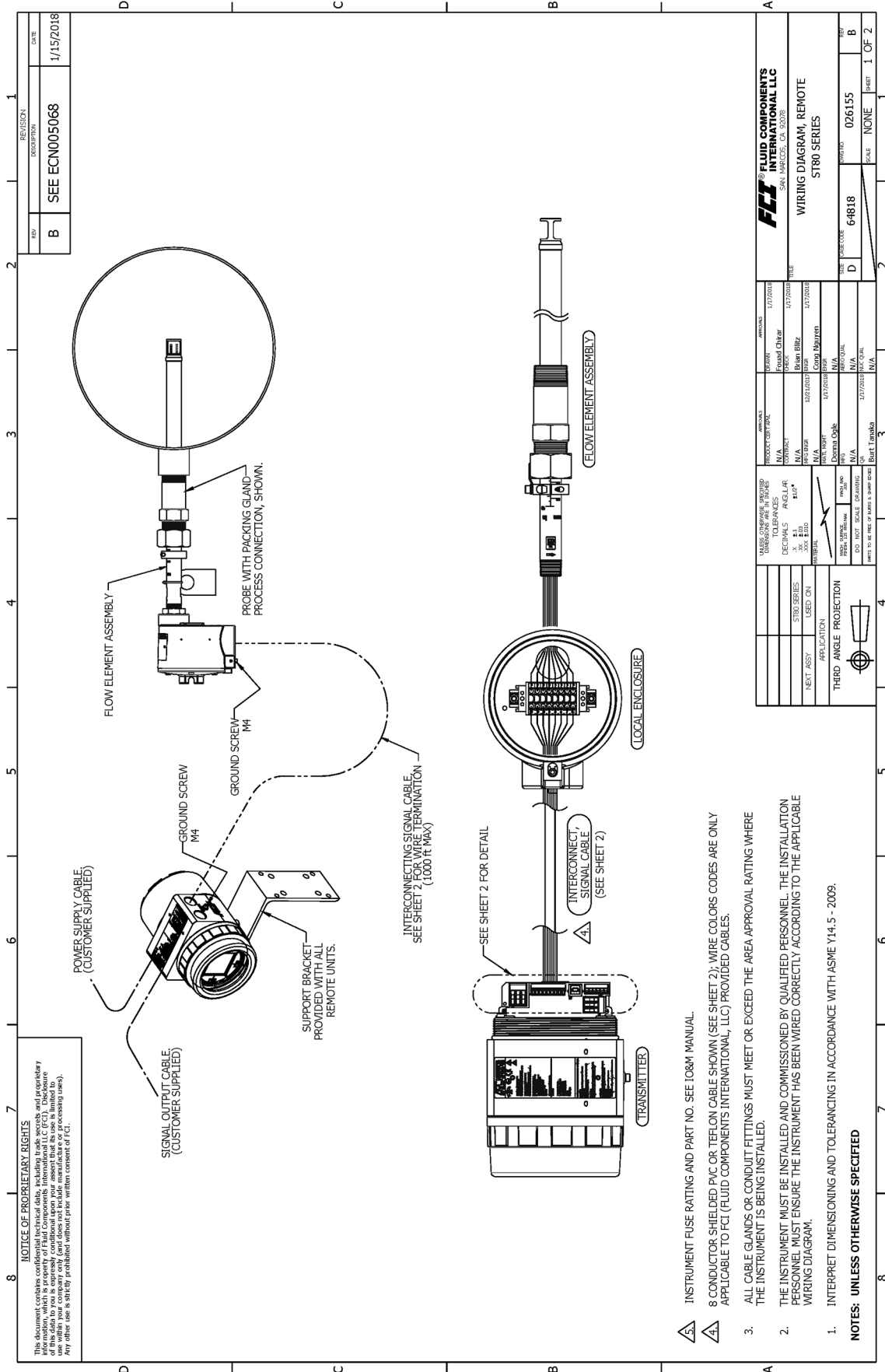

REV	DESCRIPTION	DATE
B	SEE ECN005068	1/15/2018

<b>FCI</b> <b>FLUID COMPONENTS INTERNATIONAL LLC</b> 2841 LINDSEY, CA 95002	
WIRING DIAGRAM, REMOTE ST80 SERIES	
ORDER NO. 17172018 CHECK FOUND CHECK FROM BOM 17172018 CADD DRAWING 17172018	REV. 026155 SCALE NONE SHEET 1 OF 2
PROJECT NAME PROJECT CONTRACT PROJECT NO. 102102018 PROJECT DATE 17172018	PART NO. 64818 PART NAME Burt, Transmitter
TOLERANCES UNLESS OTHERWISE SPECIFIED DECIMALS IN CHARS .XX .XXX .XXX FRACTIONS 1/32 1/64 1/128 ANGLES DECIMALS .1 .2 .3 HOLE DIA. TOLERANCE .0005 HOLE DIA. TOLERANCE .0010 HOLE DIA. TOLERANCE .0015	THIRD ANGLE PROJECTION FIRST ANGLE PROJECTION
NEXT ASSY USED ON ST80 SERIES	APPLICATION THIRD ANGLE PROJECTION

- 1. INSTRUMENT FUSE RATING AND PART NO. SEE IORM MANUAL.
- 2. 8 CONDUCTOR SHIELDED PVC OR TEFロン CABLE SHOWN (SEE SHEET 2); WIRE COLORS CODES ARE ONLY APPLICABLE TO FCI (FLUID COMPONENTS INTERNATIONAL, LLC) PROVIDED CABLES.
- 3. ALL CABLE GLANDS OR CONDUIT FITTINGS MUST MEET OR EXCEED THE AREA APPROVAL RATING WHERE THE INSTRUMENT IS BEING INSTALLED.
- 4. THE INSTRUMENT MUST BE INSTALLED AND COMMISSIONED BY QUALIFIED PERSONNEL. THE INSTALLATION PERSONNEL MUST ENSURE THE INSTRUMENT HAS BEEN WIRED CORRECTLY ACCORDING TO THE APPLICABLE WIRING DIAGRAM.

NOTES: UNLESS OTHERWISE SPECIFIED

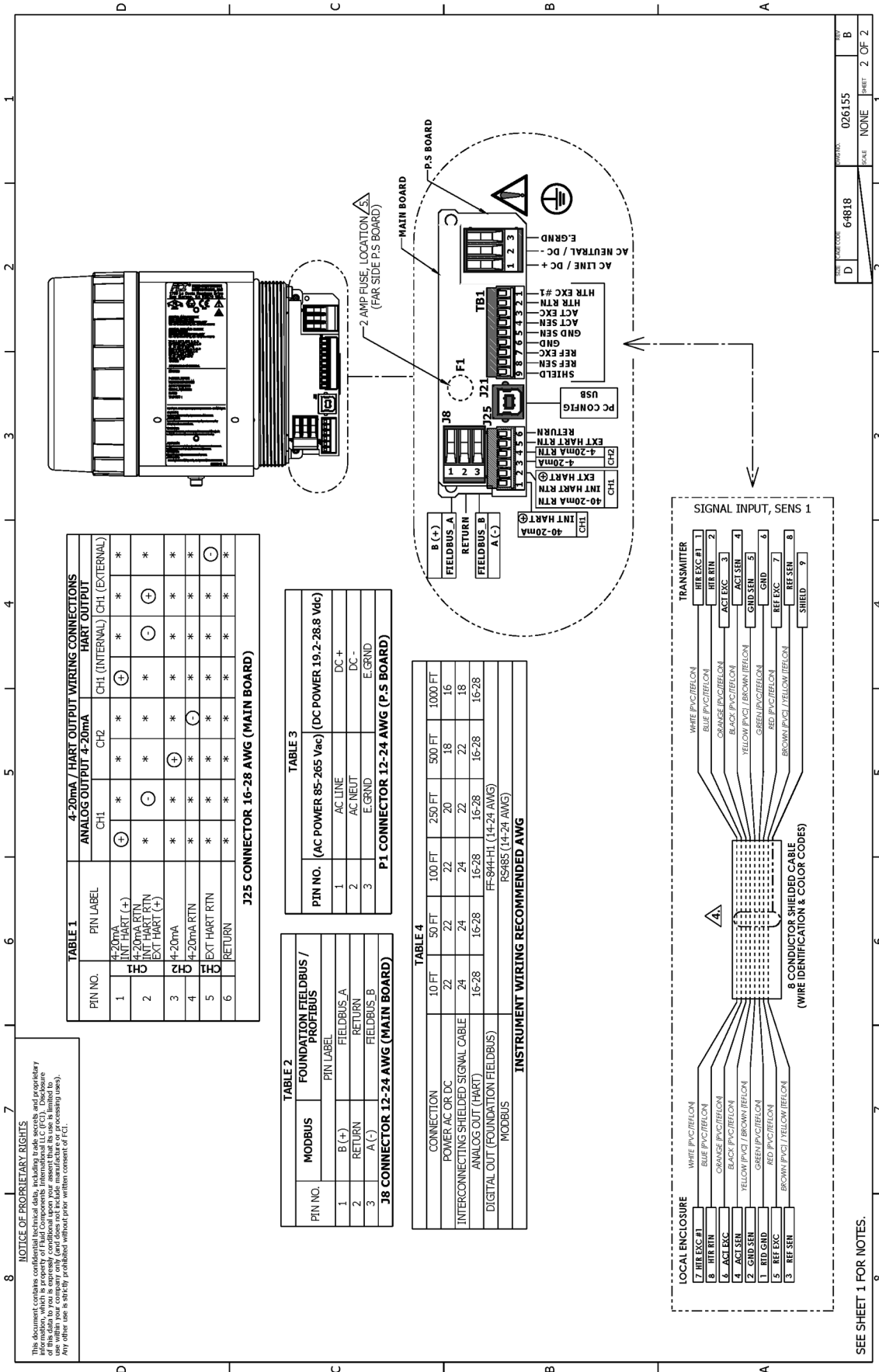

**TABLE 1**

PIN NO.	PIN LABEL	4-20mA / HART OUTPUT WIRING CONNECTIONS	
		ANALOG OUTPUT 4-20mA	HART OUTPUT
1	4-20mA INT HART (+)	CHI	CHI (INTERNAL)   CHI (EXTERNAL)
2	4-20mA RTN	CH2	CH2
3	4-20mA EXT HART (+)	CH1	CH1 (INTERNAL)   CHI (EXTERNAL)
4	4-20mA RTN	CH2	CH2
5	EXT HART RTN	CH1	CH1 (INTERNAL)   CHI (EXTERNAL)
6	RETURN	CH2	CH2

**J25 CONNECTOR 16-28 AWG (MAIN BOARD)**

**TABLE 2**

PIN NO.	MODBUS	FOUNDATION FIELDBUS / PROFIBUS	PIN LABEL
1	B (+)	FIELDBUS_A	FIELD BUS A
2	RETURN	RETURN	RETURN
3	A (-)	FIELDBUS_B	FIELD BUS B

**J8 CONNECTOR 12-24 AWG (MAIN BOARD)**

**TABLE 3**

PIN NO.	(AC POWER 85-265 Vac) (DC POWER 19.2-28.8 Vdc)
1	AC LINE
2	AC NEUT
3	E.GRND

**P1 CONNECTOR 12-24 AWG (P-S BOARD)**

**TABLE 4**

CONNECTION	10 FT	50 FT	100 FT	250 FT	500 FT	1000 FT
POWER AC OR DC	22	22	20	18	16	16
INTERCONNECTING SHIELDED SIGNAL CABLE	24	24	22	22	18	18
ANALOG OUT (HART)	16-28	16-28	16-28	16-28	16-28	16-28
DIGITAL OUT (FOUNDATION FIELDBUS)						
MODBUS						

**INSTRUMENT WIRING RECOMMENDED AWG**

RS485 (14-24 AWG)

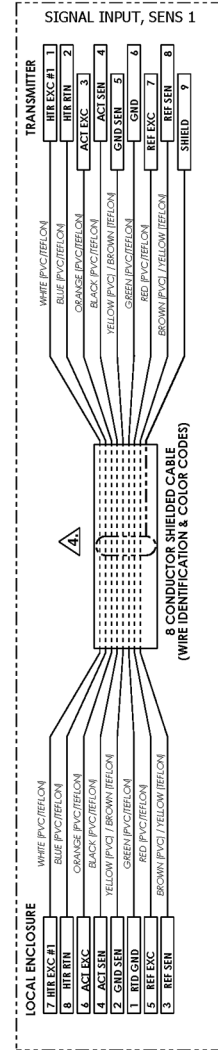

**NOTICE OF PROPRIETARY RIGHTS**

This document contains confidential and proprietary information of Fluid Components International LLC (FCI). Disclosure of this data to you is expressly conditional upon your agreement that its use is limited to the specific application and equipment for which it is intended. Any other use is strictly prohibited without prior written consent of FCI.

REV	026155	1
SCALE	NONE	1
SHEET	2 OF 2	1

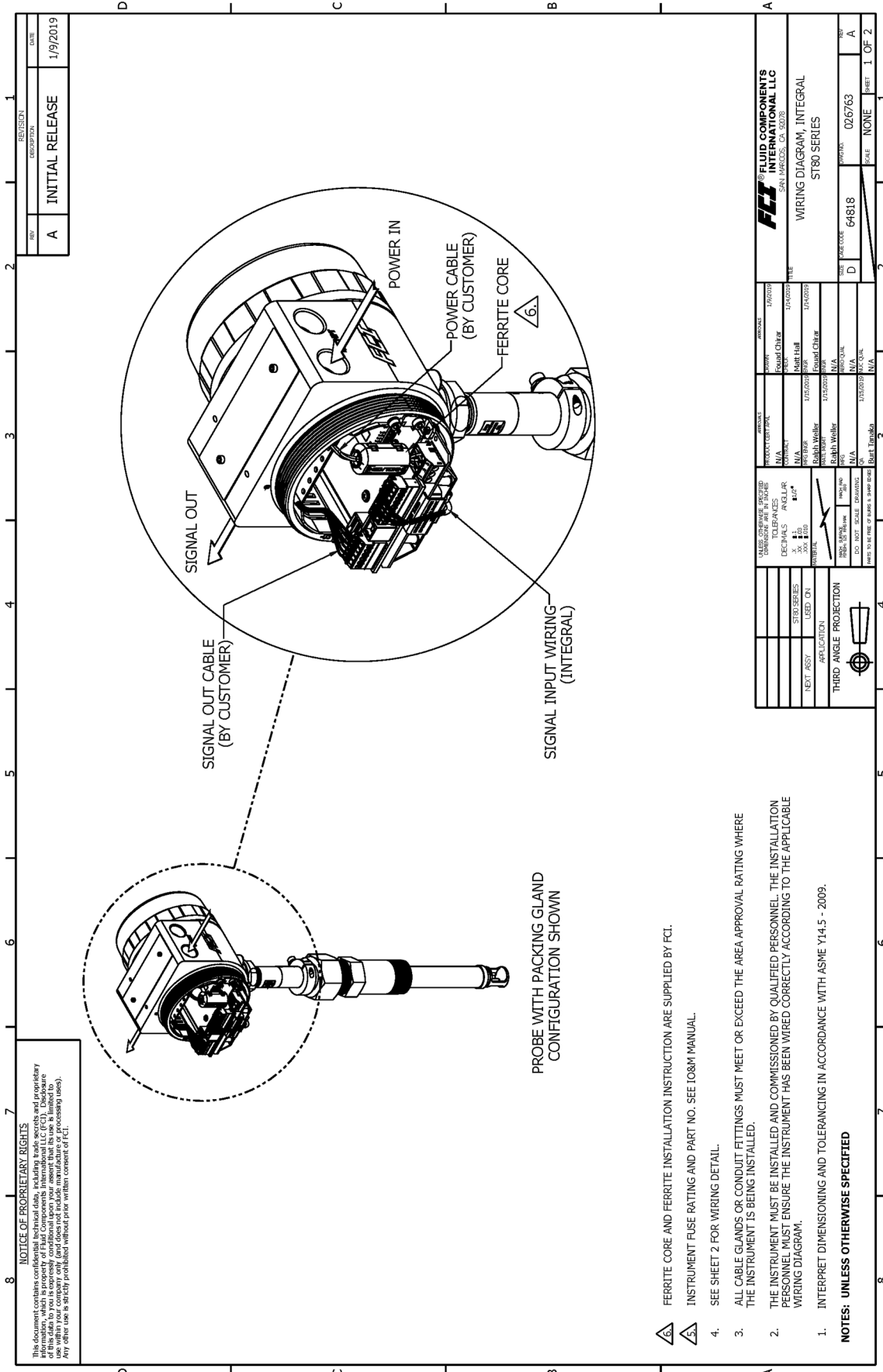

**8. NOTICE OF PROPRIETARY RIGHTS**  
 This document contains confidential technical data, including trade secrets and proprietary information, which is property of Fluid Components International LLC (FCI). Disclosure of this information to any third party without the express written consent of FCI is prohibited. Any other use is strictly prohibited without prior written consent of FCI.

PROBE WITH PACKING GLAND CONFIGURATION SHOWN

- 1. INTERPRET DIMENSIONING AND TOLERANCING IN ACCORDANCE WITH ASME Y14.5 - 2009.
- 2. THE INSTRUMENT MUST BE INSTALLED AND COMMISSIONED BY QUALIFIED PERSONNEL. THE INSTALLATION PERSONNEL MUST ENSURE THE INSTRUMENT HAS BEEN WIRED CORRECTLY ACCORDING TO THE APPLICABLE WIRING DIAGRAM.
- 3. ALL CABLE GLANDS OR CONDUIT FITTINGS MUST MEET OR EXCEED THE AREA APPROVAL RATING WHERE THE INSTRUMENT IS BEING INSTALLED.
- 4. INSTRUMENT FUSE RATING AND PART NO. SEE IO&M MANUAL.

**NOTES: UNLESS OTHERWISE SPECIFIED**



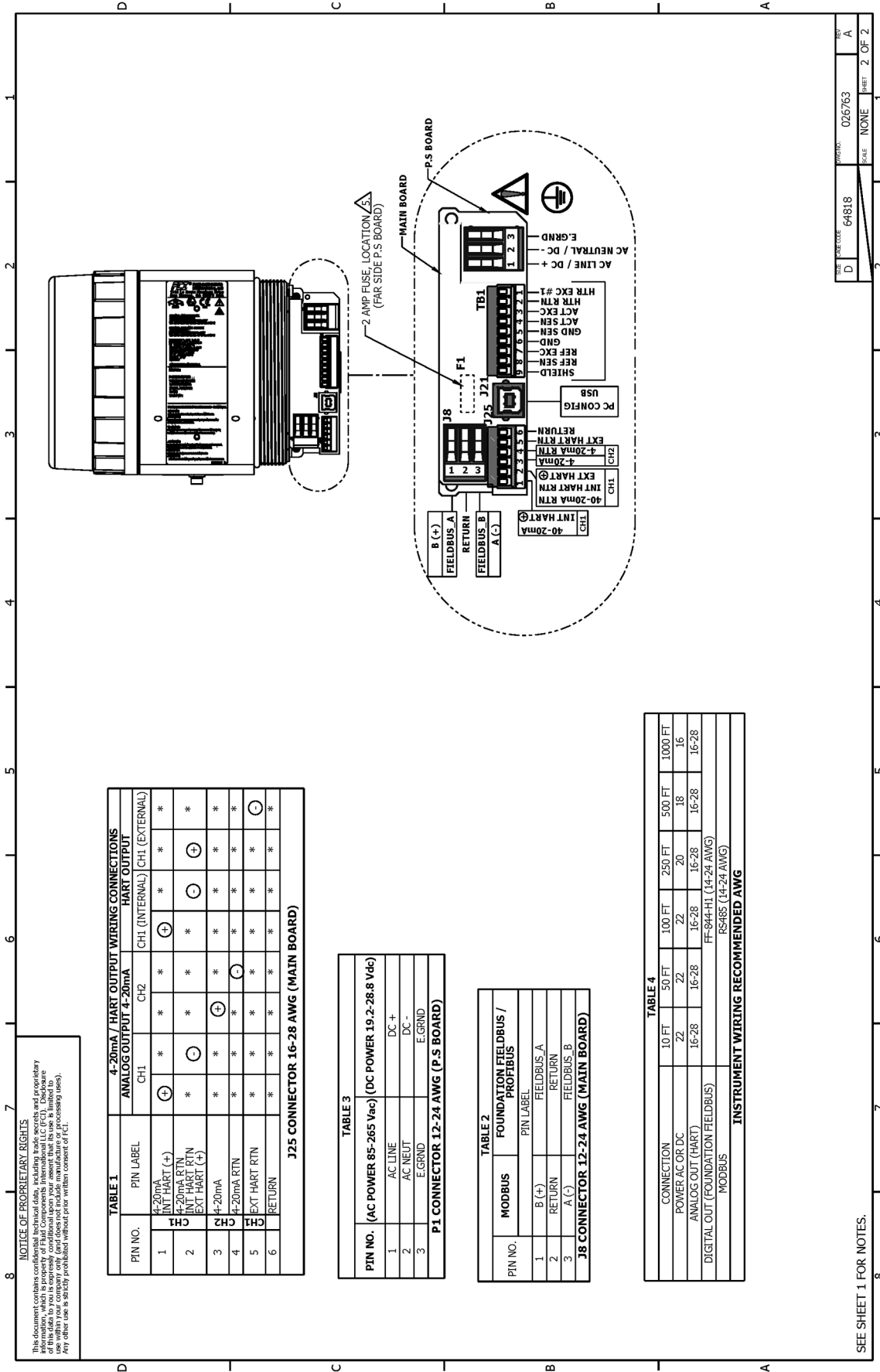

**8 NOTICE OF PROPRIETARY RIGHTS**  
 This document contains confidential technical data, including trade secrets and proprietary information, which is property of Fluid Components International LLC (FCI). Disclosure of this information to any third party without the express written consent of FCI is prohibited. Any other use is strictly prohibited without prior written consent of FCI.

**TABLE 1 4-20mA / HART OUTPUT WIRING CONNECTIONS**

PIN NO.	PIN LABEL	4-20mA ANALOG OUTPUT		HART OUTPUT	
		CH1	CH2	CH1 (INTERNAL)	CH1 (EXTERNAL)
1	4-20mA INT HART (+)	*	*	*	*
2	4-20mA RTN INT HART RTN	*	*	*	*
3	4-20mA EXT HART (+)	*	*	*	*
4	4-20mA RTN	*	*	*	*
5	EXT HART RTN	*	*	*	*
6	RETURN	*	*	*	*

**J25 CONNECTOR 16-28 AWG (MAIN BOARD)**

**TABLE 3 (AC POWER 85-265 Vac) (DC POWER 19.2-28.8 Vdc)**

1	AC LINE	DC +
2	AC NEUT	DC -
3	E.GROUND	E.GROUND

**P1 CONNECTOR 12-24 AWG (P.S BOARD)**

**TABLE 2 FOUNDATION FIELDBUS / PROFIBUS**

PIN NO.	MODBUS	FOUNDATION FIELDBUS / PROFIBUS
1	B (+)	FIELDBUS A
2	RETURN	RETURN
3	A (-)	FIELDBUS B

**J8 CONNECTOR 12-24 AWG (MAIN BOARD)**

**TABLE 4 CONNECTION**

CONNECTION	10 FT	50 FT	100 FT	250 FT	500 FT	1000 FT
POWER AC OR DC	22	22	20	20	18	16
ANALOG OUT (HART)	16-28	16-28	16-28	16-28	16-28	16-28
DIGITAL OUT (FOUNDATION FIELDBUS)	FF-894-H1 (14-24 AWG)					
MODBUS	RS485 (14-24 AWG)					

**INSTRUMENT WIRING RECOMMENDED AWG**

REV	DATE	DESCRIPTION	BY
D	02/5/63	64818	A

SCALE: NONE SHEET 2 OF 2

SEE SHEET 1 FOR NOTES.

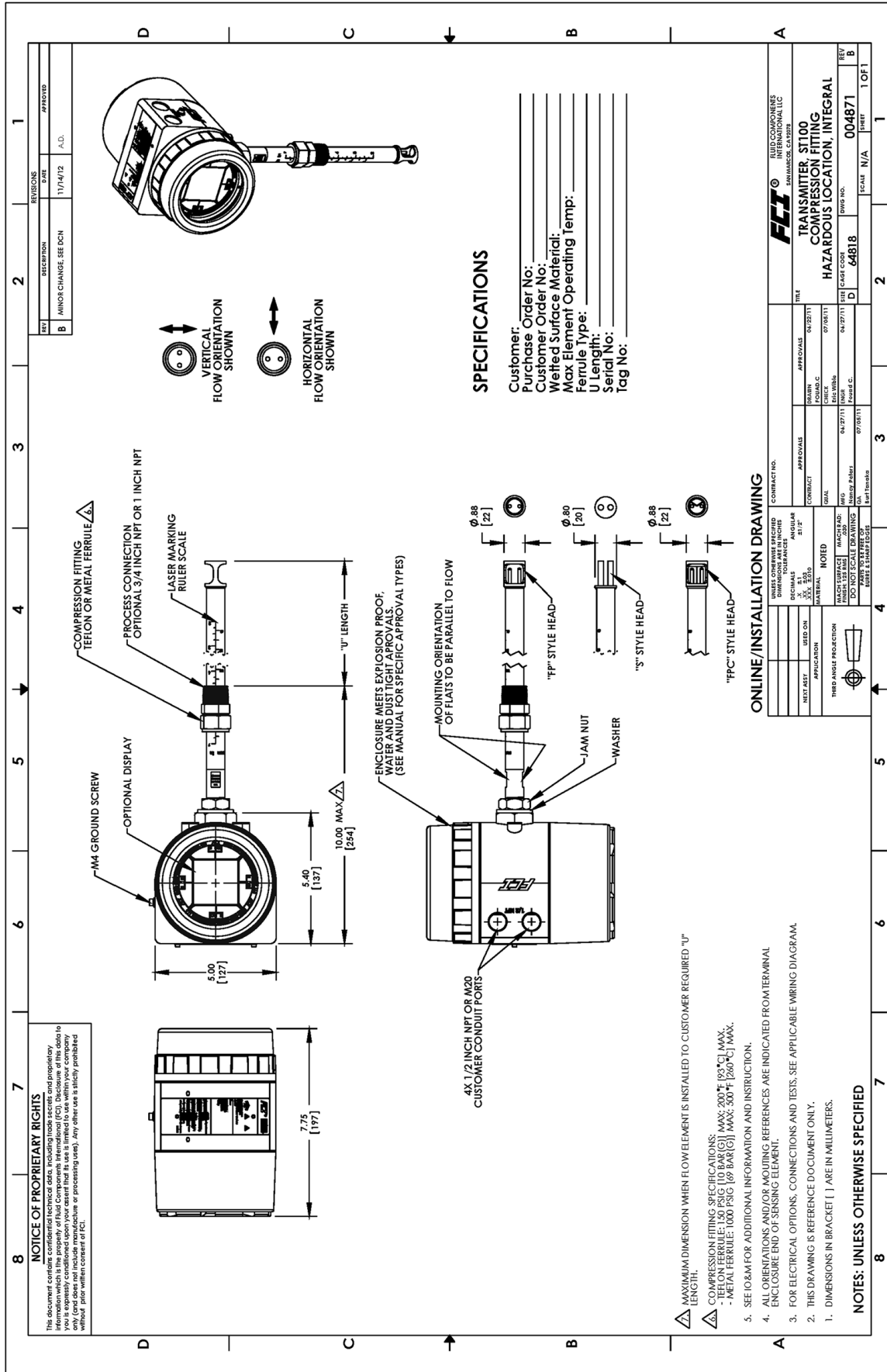

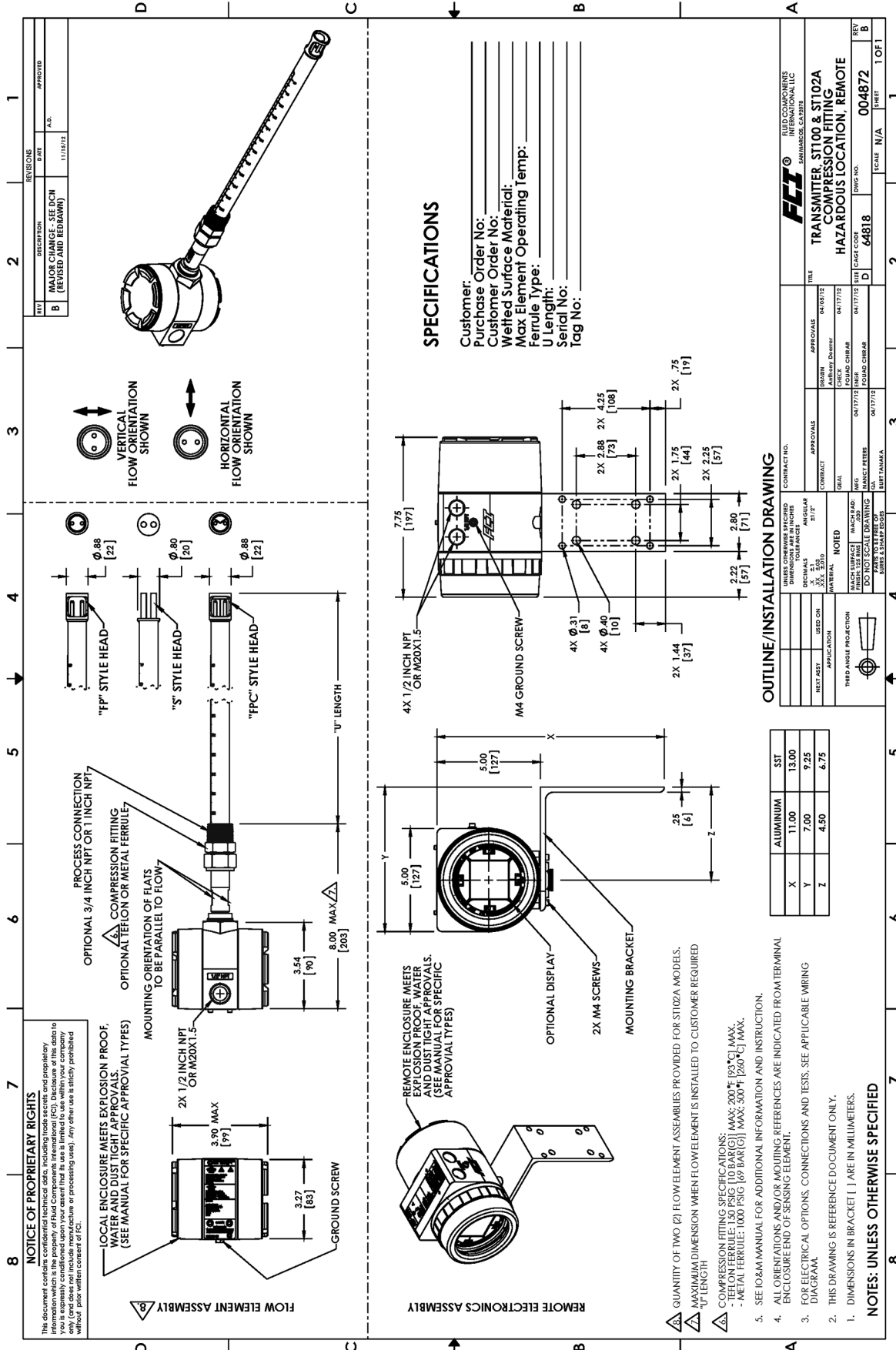

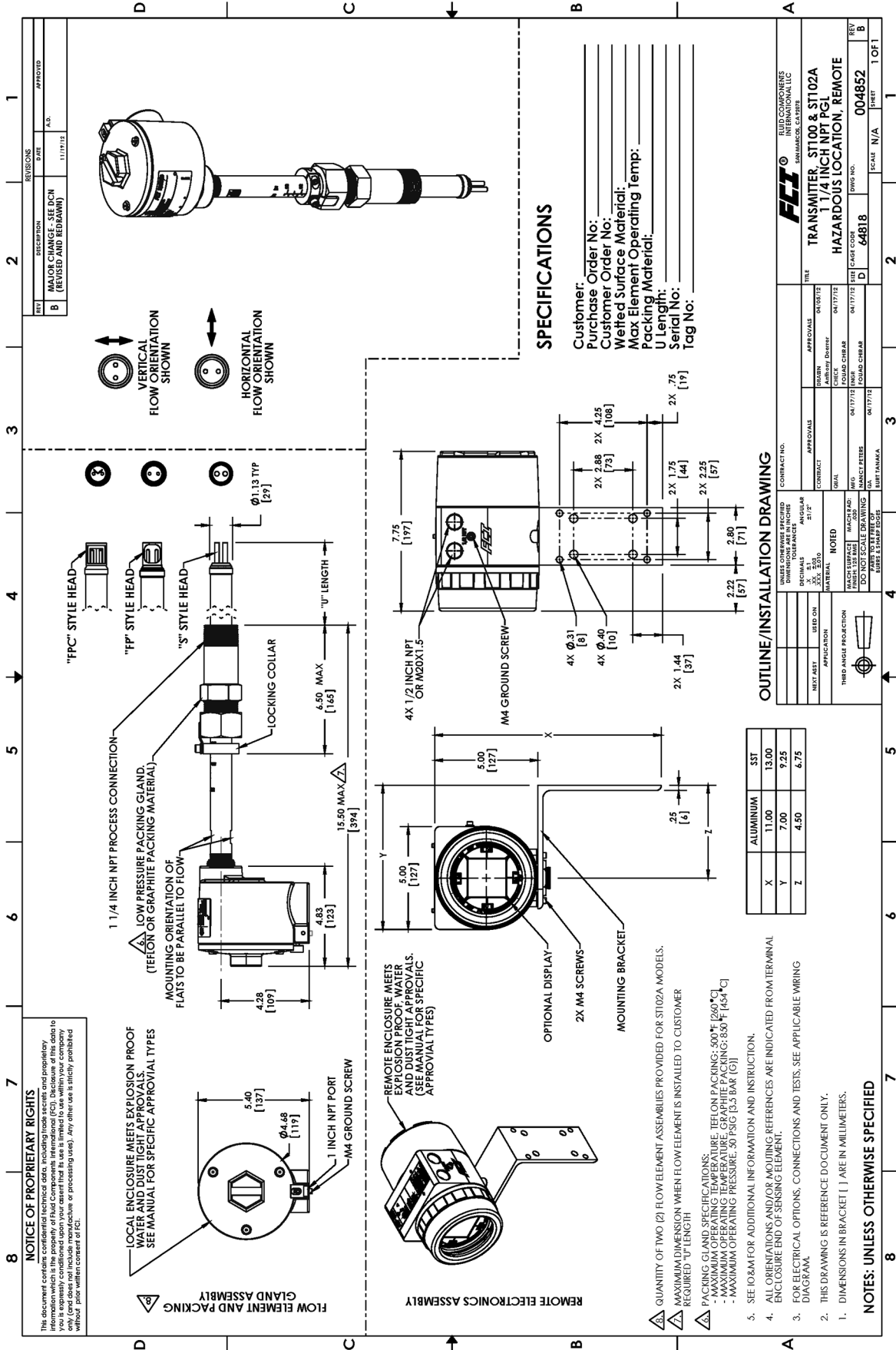

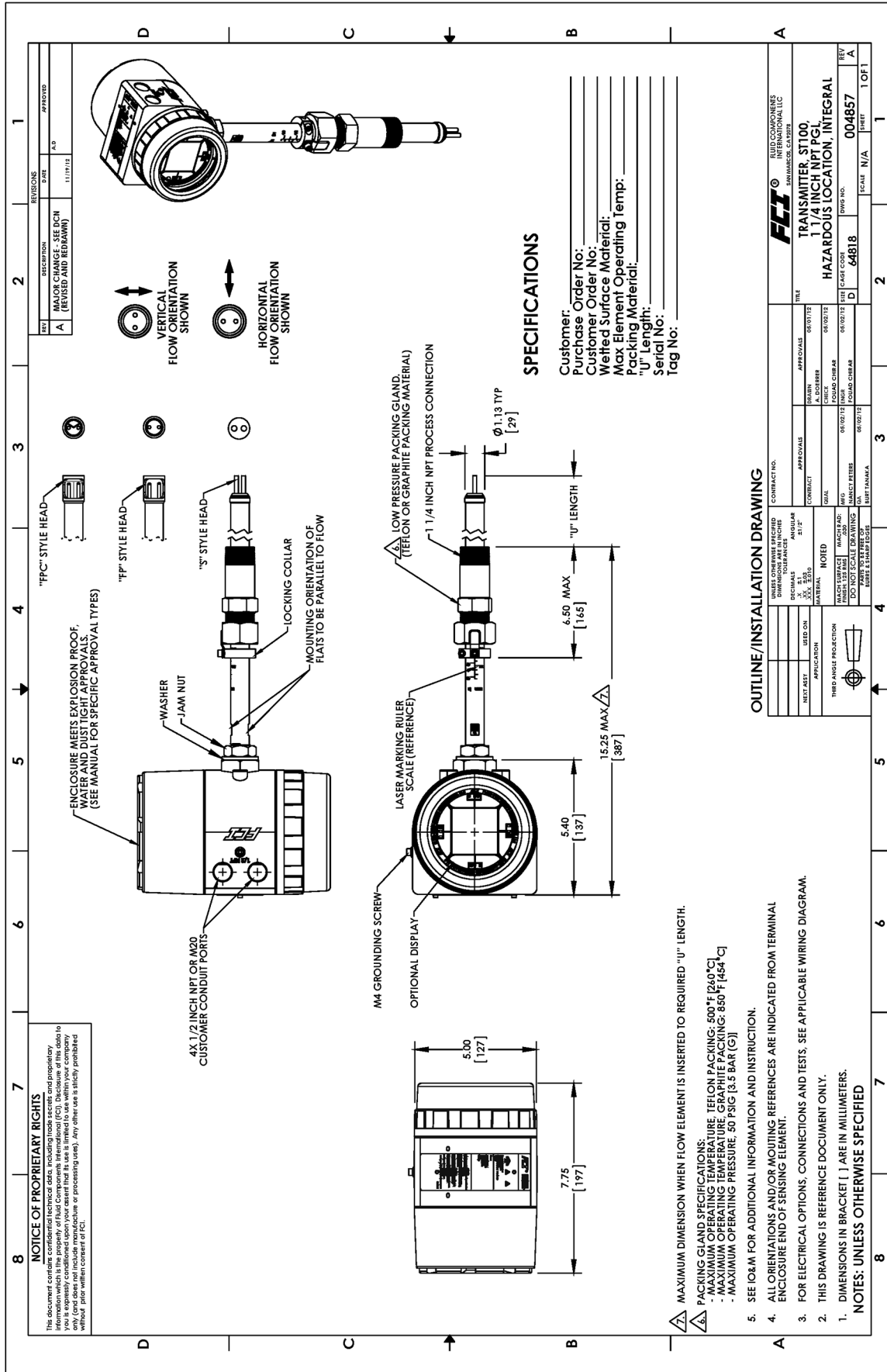



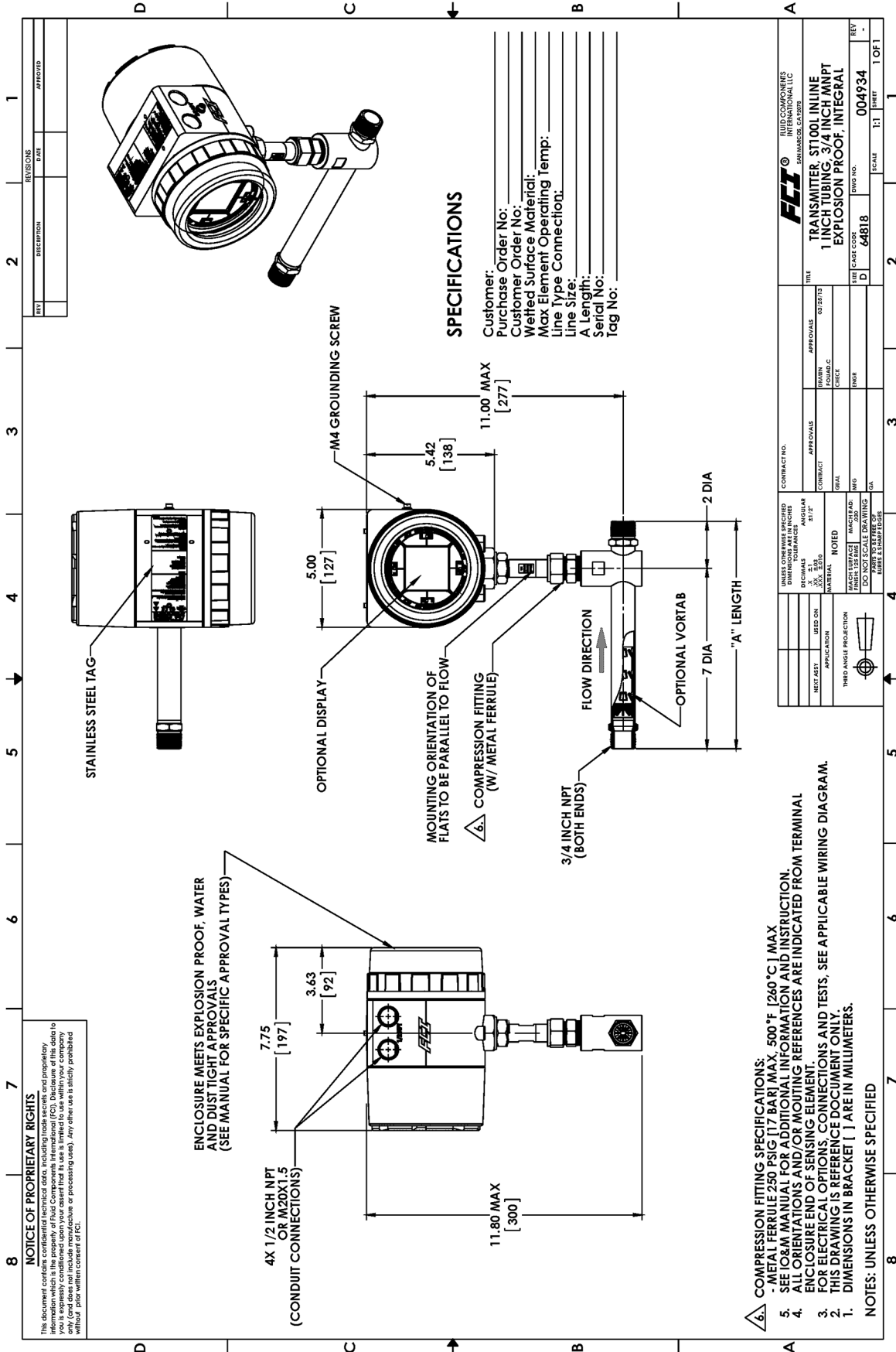

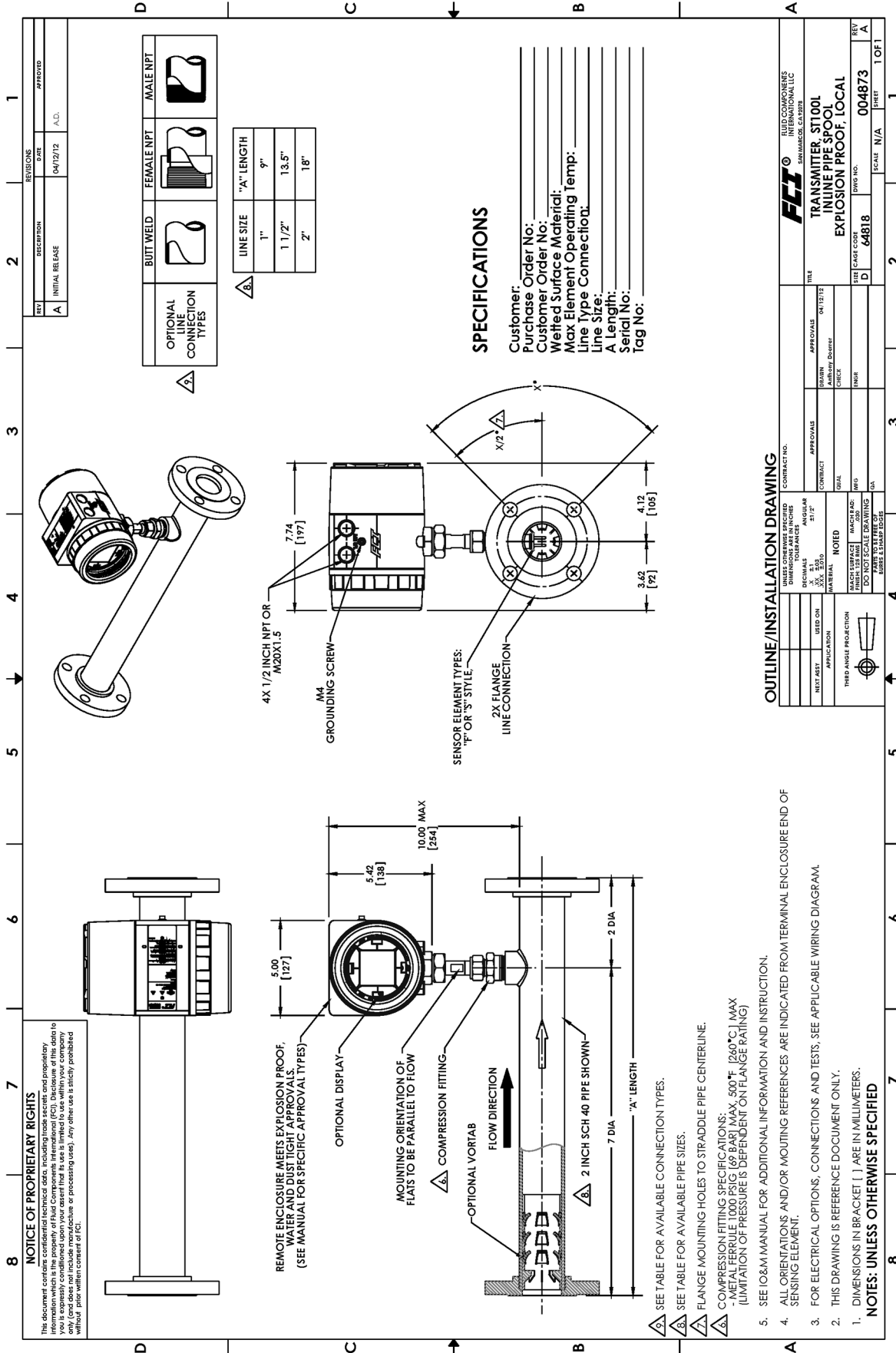



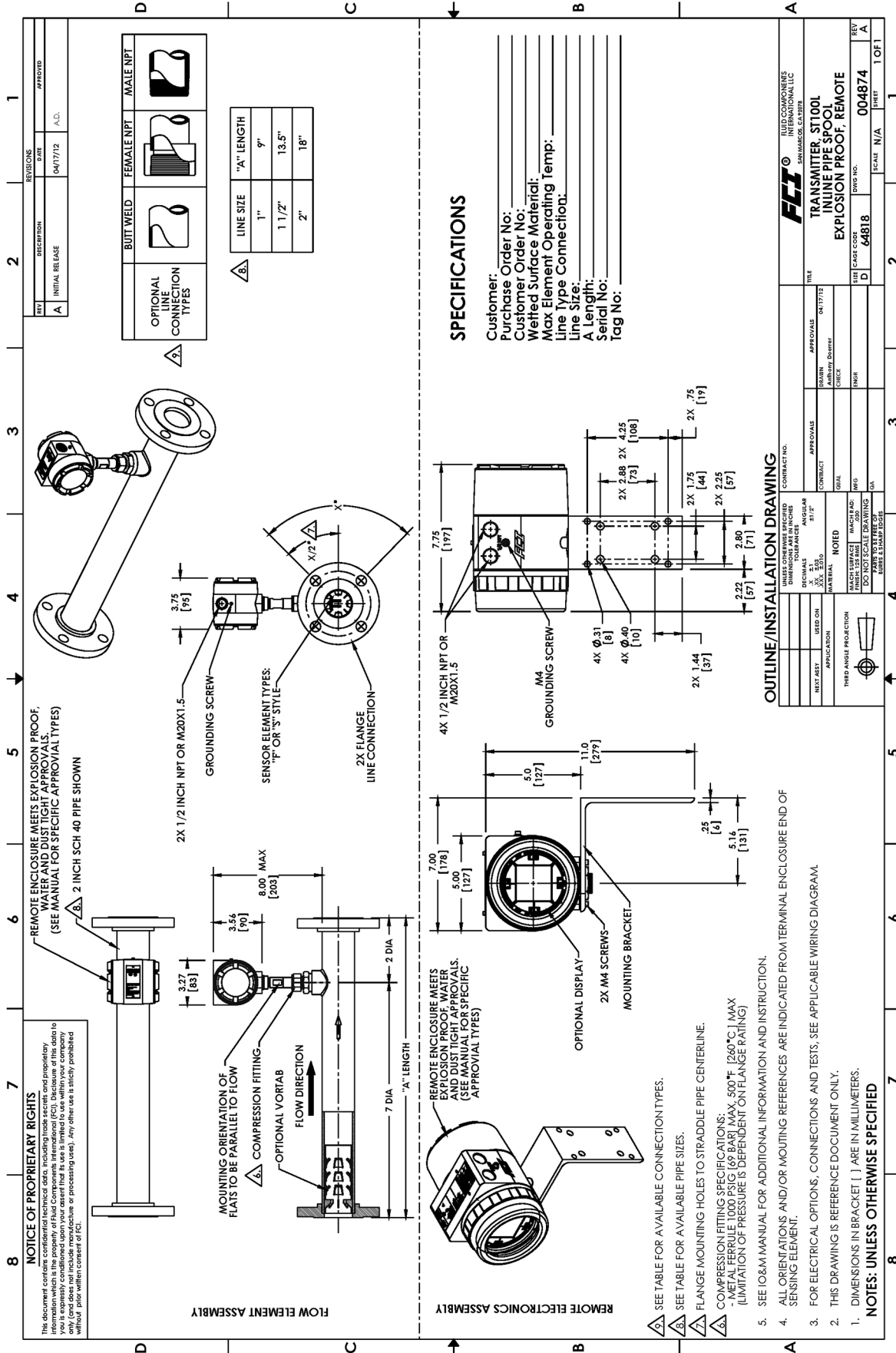

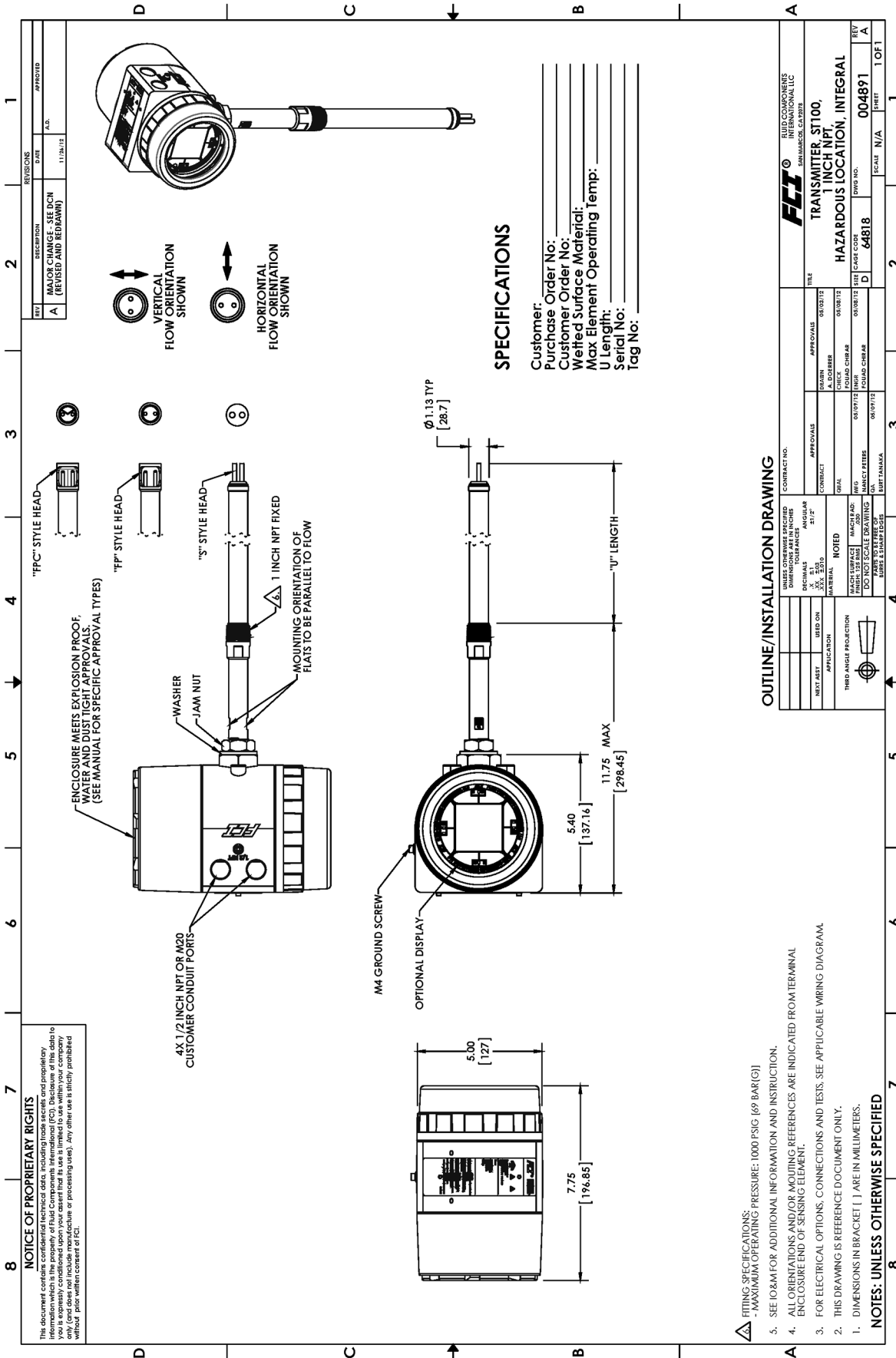

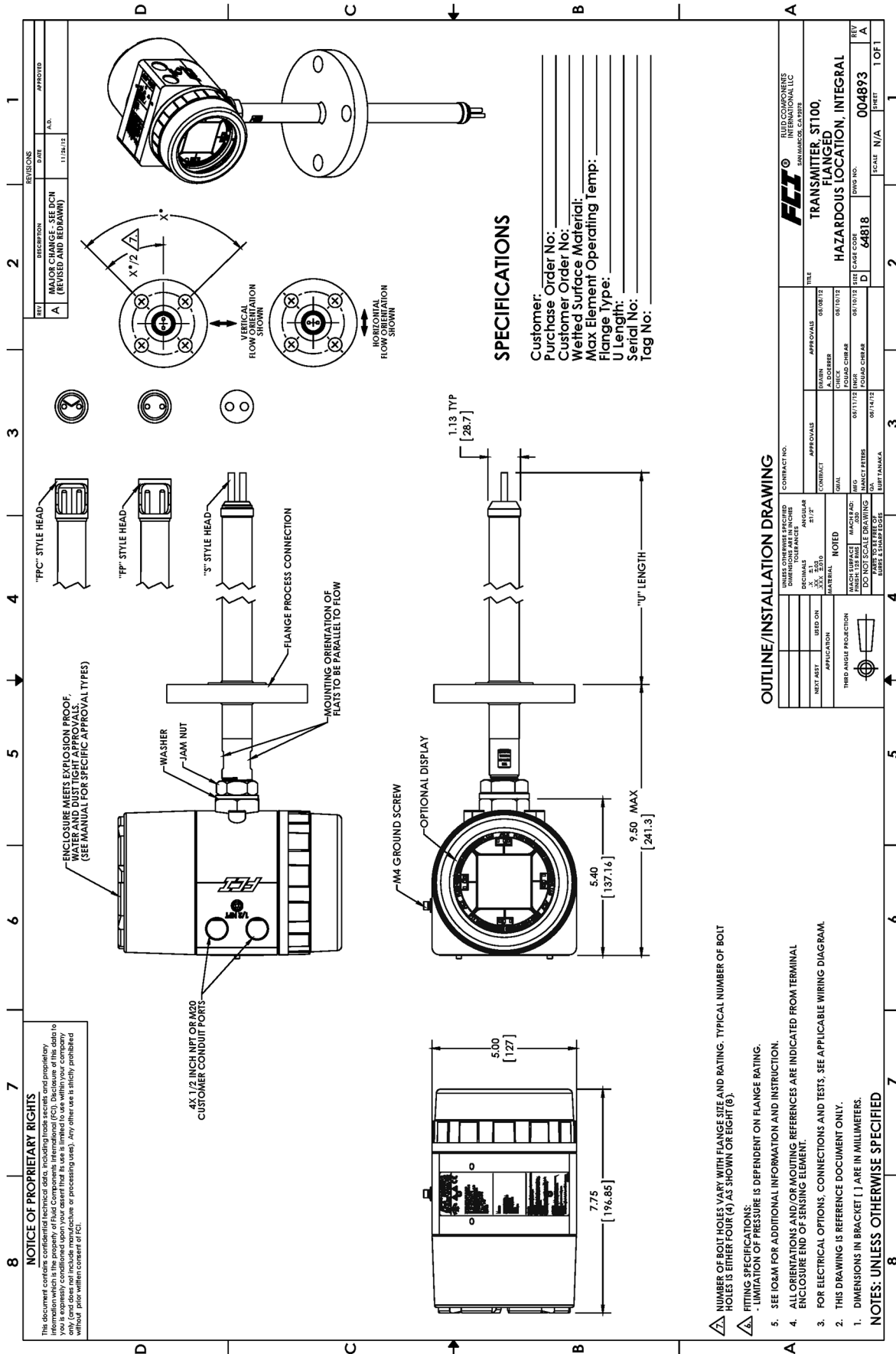

- 1. DIMENSIONS IN BRACKET [ ] ARE IN MILLIMETERS.
- 2. THIS DRAWING IS REFERENCE DOCUMENT ONLY.
- 3. FOR ELECTRICAL OPTIONS, CONNECTIONS AND TESTS, SEE APPLICABLE WIRING DIAGRAM.
- 4. ALL ORIENTATIONS AND/OR MOUNTING REFERENCES ARE INDICATED FROM TERMINAL ENCLOSURE END OF SENSING ELEMENT.
- 5. SEE IOM FOR ADDITIONAL INFORMATION AND INSTRUCTION.
- 6. LIMITATION OF PRESSURE IS DEPENDENT ON FLANGE RATING.
- 7. NUMBER OF BOLT HOLES VARY WITH FLANGE SIZE AND RATING. TYPICAL NUMBER OF BOLT HOLES IS EITHER FOUR (4) AS SHOWN OR EIGHT (8).

This Page Intentionally Left Blank

## APPENDIX B      ADDITIONAL INFORMATION

This appendix contains the following information:

- Parameters Report from the ST80/ST80L Configuration Application (Sample)
- HMI Menu Outline
- ST80/ST80L Configuration Software Menu Outline (v3.2.0.x)
- Instructions: Installing Sun Shield on ST80/ST80L Integral Enclosure
- Instructions: Installing Sun Shield on ST80/ST80L Remote Enclosure

**Parameters Report from the ST80/ST80L Configuration Application (Sample)**

Destination	Parameter Name	CLI	Parameter Value
CORE	Date and Time:	RC	3/25/2021 5:39:29 PM
CORE	Unit Serial Number:	2Y	TN511
CORE	Cust Number:	2X	
CORE	Cust Name:	CU	
CORE	Core Version:	4V	1.07D
CORE	HMI Version:	7Q	
CORE	MAC Address:	4R	70.B3.D5.9F.93.31
CORE	HART Serial Number:	2S	511
CORE	Ext Op Mode:	8R	1
CORE	Ext Op Submode:	8R	0
CORE	4-20mA Inp Adj Gain:	8S	1.021655
CORE	4-20mA Inp Adj Offset:	8S	-24.4878
CORE	EFI Flow Min.:	8T	100
CORE	EFI Flow Max.:	8T	5000
CORE	EFI Flow Units:	8T	73
CORE	EGS Threshold1:	8U	0
CORE	EGS Group1 ID:	8U	0
CORE	EGS Threshold2:	8U	0
CORE	EGS Group2 ID:	8U	0
CORE	EGS Threshold3:	8U	0
CORE	EGS Group3 ID:	8U	0
CORE	EGS Threshold4:	8U	0
CORE	EGS Group4 ID:	8U	0
CORE	EGS Group5 ID:	8U	0
CORE GROUP 1	Group Name:	4A	Air
CORE GROUP 1	Flow Unit:	EU	74
CORE GROUP 1	Flow Cust Min:	FR	0
CORE GROUP 1	Flow Cust Max:	FS	17.71255
CORE GROUP 1	Temp Unit:	TU	70
CORE GROUP 1	Temp Cust Min:	TM	0
CORE GROUP 1	Temp Cust Max:	TX	500
CORE GROUP 1	Pres Cust Min:	OY	0
CORE GROUP 1	Pres Cust Max:	OZ	160
CORE GROUP 1	Line Size 0:	L0	25.4
CORE GROUP 1	Line Size 1:	L1	254
CORE GROUP 1	Line Unit:	LU	1
CORE GROUP 1	K Factor 1:	K1	0
CORE GROUP 1	K Factor 2:	K2	1
CORE GROUP 1	K Factor 3:	K3	0
CORE GROUP 1	K Factor 4:	K4	0
CORE GROUP 1	Totalizer Enable:	TO	0
CORE GROUP 1	Flow Min SFPS:	FM	0
CORE GROUP 1	Flow Max SFPS:	FX	100
CORE GROUP 1	Temp Factory Min:	2I	0
CORE GROUP 1	Temp Factory Max:	2J	500
CORE GROUP 1	AuxInput ExtOp=0 Pres=1:	F4	0
CORE GROUP 1	PressureTransducerPresent:	2K	0,0,0,0,0,0,0,0,0,0,0,0,0,0,0,0
CORE GROUP 1	Pres Min PSIG:	2G	0
CORE GROUP 1	Pres Max PSIG:	2H	160
CORE GROUP 1	Pres Unit:	PU	0
CORE GROUP 1	Std Density:	DN	0.074975
CORE GROUP 1	Analog Out 1:	0A	6
CORE GROUP 1	CH1 4 mA:	0A	0
CORE GROUP 1	4 mA DAC1:	0A	9723
CORE GROUP 1	CH1 20 mA:	0A	14.17004

Destination	Parameter Name	CLI	Parameter Value
CORE GROUP 1	20 mA DAC1:	0A	53619
CORE GROUP 1	Namur1(0=Off, 1=On):	0A	0
CORE GROUP 1	Namur DAC1:	0A	9236
CORE GROUP 1	Analog Out 2:	0B	7
CORE GROUP 1	CH2 4 mA:	0B	0
CORE GROUP 1	4 mA DAC2:	0B	11335
CORE GROUP 1	CH2 20 mA:	0B	150
CORE GROUP 1	20 mA DAC2:	0B	54401
CORE GROUP 1	Namur2(0=Off, 1=On):	0B	0
CORE GROUP 1	Namur DAC2:	0B	54401
CORE GROUP 1	Analog Out 3:	0C	7
CORE GROUP 1	CH3 4 mA:	0C	0
CORE GROUP 1	4 mA DAC3:	0C	11014
CORE GROUP 1	CH3 20 mA:	0C	150
CORE GROUP 1	20 mA DAC3:	0C	54294
CORE GROUP 1	Namur3(0=Off, 1=On):	0C	0
CORE GROUP 1	Namur DAC3:	0C	54294
CORE GROUP 1	EIA Factor1:	4C	1
CORE GROUP 1	EIA Factor2:	4C	0
CORE GROUP 1	EIA Factor3:	4C	0
CORE GROUP 1	EIA Factor4:	4C	0
FE START	Version:	CV	1.07D
FE 1 GROUP 1	dR Min:	C7	1
FE 1 GROUP 1	dR Max:	C7	118.78
FE 1 GROUP 1	Cal Ref:	C7	1080.17
FE 1 GROUP 1	tcs1p:	C8	0
FE 1 GROUP 1	tcs1p0:	C8	0
FE 1 GROUP 1	breakpoint:	C8	58.62
FE 1 GROUP 1	Line Size 0:	C8	4.026
FE 1 GROUP 1	Line Size 1:	C8	0
FE 1 GROUP 1	Flow Min SFPS:	C8	0
FE 1 GROUP 1	Flow Max SFPS:	C8	150.1
FE 1 GROUP 1	Flow Cust Min:	C8	0
FE 1 GROUP 1	Flow Cust Max:	C8	125
FE 1 GROUP 1	Std Density:	C8	0.074915
FE 1 GROUP 1	Line Size Unit:	C8	0
FE 1 GROUP 1	Flow Unit:	C8	70
FE 1 GROUP 1	Temp Unit:	C8	70
FE 1 GROUP 1	Pres Unit:	C8	2
FE 1 GROUP 1	K Factor 1:	C8	0
FE 1 GROUP 1	K Factor 2:	C8	1
FE 1 GROUP 1	idR Error Tolerance	DU	0.5
FE 1 GROUP 1	Exp Low idR:	CC	59.50459
FE 1 GROUP 1	Exp Mid idR:	CC	100.0592
FE 1 GROUP 1	Exp High idR:	CC	150.6526
FE 1 GROUP 1	L Temp dR Gain:	CA	1.251044
FE 1 GROUP 1	L Temp dR Offset:	CA	-0.4861549
FE 1 GROUP 1	L Temp RefR Gain:	CA	1.250618
FE 1 GROUP 1	L Temp RefR Offset:	CA	0.4064261
FE 1 GROUP 1	DefaultAbsPSIOffset (PE):	PE	0
FE 1 GROUP 1	DefaultGaugePSIOffset (PB):	PE	0
FE 1 GROUP 1	PressureUnitCode:	PU	2
FE 1 GROUP 1	PressureUnitType (PD):	PD	2
FE 1 GROUP 1	PressureRangeMin:	PV	0
FE 1 GROUP 1	PressureRangeMax:	PV	160

Destination	Parameter Name	CLI	Parameter Value
FE 1 GROUP 1	PressureRangeStr (PV):	PV	0,160
FE 1 GROUP 1	DPoly(1,1):	C3	0.1758943
FE 1 GROUP 1	DPoly(1,2):	C3	0.9133858
FE 1 GROUP 1	DPoly(1,3):	C3	-257.7477
FE 1 GROUP 1	DPoly(1,4):	C3	23361.403
FE 1 GROUP 1	DPoly(1,5):	C3	-7325.417
FE 1 GROUP 1	H Temp dR Gain:	C9	1.251044
FE 1 GROUP 1	H Temp dR Offset:	CA	-0.4861549
FE 1 GROUP 1	H Temp RefR Gain:	CC	1.250618
FE 1 GROUP 1	H Temp RefR Offset:	C9	0.4064261
FE 1 GROUP 1	DPoly(2,1):	C5	-24.614416
FE 1 GROUP 1	DPoly(2,2):	C5	200.970275
FE 1 GROUP 1	DPoly(2,3):	C5	-60305.54
FE 1 GROUP 1	DPoly(2,4):	C5	7980455.9326
FE 1 GROUP 1	DPoly(2,5):	C5	-3938943.862
FE 1 GROUP 1	0=Spline 1=DPoly:	CB	0
FE 1 GROUP 1	Number of Splines:	CB	26
FE 1 GROUP 1	Spline X1:	X1	127.635
FE 1 GROUP 1	Spline X2:	X1	316.505
FE 1 GROUP 1	Spline X3:	X1	490.397
FE 1 GROUP 1	Spline X4:	X1	836.957
FE 1 GROUP 1	Spline X5:	X1	1332.16
FE 1 GROUP 1	Spline X6:	X2	2185.4
FE 1 GROUP 1	Spline X7:	X2	3498.52
FE 1 GROUP 1	Spline X8:	X2	5755.52
FE 1 GROUP 1	Spline X9:	X2	9162.16
FE 1 GROUP 1	Spline X10:	X2	14784.3
FE 1 GROUP 1	Spline X11:	X3	23999.6
FE 1 GROUP 1	Spline X12:	X3	38668.3
FE 1 GROUP 1	Spline X13:	X3	45071.5
FE 1 GROUP 1	Spline X14:	X3	0
FE 1 GROUP 1	Spline X15:	X3	0
FE 1 GROUP 1	Spline X16:	X4	0
FE 1 GROUP 1	Spline X17:	X4	0
FE 1 GROUP 1	Spline X18:	X4	0
FE 1 GROUP 1	Spline X19:	X4	0
FE 1 GROUP 1	Spline X20:	X4	0
FE 1 GROUP 1	Spline X21:	X5	0
FE 1 GROUP 1	Spline X22:	X5	0
FE 1 GROUP 1	Spline X23:	X5	0
FE 1 GROUP 1	Spline X24:	X5	0
FE 1 GROUP 1	Spline X25:	X5	0
FE 1 GROUP 1	Spline X26:	X6	0
FE 1 GROUP 1	Spline Y1:	Y1	13.37557
FE 1 GROUP 1	Spline Y2:	Y1	16.06762
FE 1 GROUP 1	Spline Y3:	Y1	17.70942
FE 1 GROUP 1	Spline Y4:	Y1	20.44811
FE 1 GROUP 1	Spline Y5:	Y1	23.51411
FE 1 GROUP 1	Spline Y6:	Y2	27.41981
FE 1 GROUP 1	Spline Y7:	Y2	31.75774
FE 1 GROUP 1	Spline Y8:	Y2	37.29303
FE 1 GROUP 1	Spline Y9:	Y2	43.46411
FE 1 GROUP 1	Spline Y10:	Y2	50.68928
FE 1 GROUP 1	Spline Y11:	Y3	58.8932
FE 1 GROUP 1	Spline Y12:	Y3	67.64727



Destination	Parameter Name	CLI	Parameter Value
FE 1 GROUP 1	Spline Y13:	Y3	70.83611
FE 1 GROUP 1	Spline Y14:	Y3	0
FE 1 GROUP 1	Spline Y15:	Y3	0
FE 1 GROUP 1	Spline Y16:	Y4	0
FE 1 GROUP 1	Spline Y17:	Y4	0
FE 1 GROUP 1	Spline Y18:	Y4	0
FE 1 GROUP 1	Spline Y19:	Y4	0
FE 1 GROUP 1	Spline Y20:	Y4	0
FE 1 GROUP 1	Spline Y21:	Y5	0
FE 1 GROUP 1	Spline Y22:	Y5	0
FE 1 GROUP 1	Spline Y23:	Y5	0
FE 1 GROUP 1	Spline Y24:	Y5	0
FE 1 GROUP 1	Spline Y25:	Y5	0
FE 1 GROUP 1	Spline Y26:	Y6	0
FE 1 GROUP 1	Spline Z1:	W1	14.59323796
FE 1 GROUP 1	Spline Z2:	W1	20.31745992
FE 1 GROUP 1	Spline Z3:	W1	5.377977595
FE 1 GROUP 1	Spline Z4:	W1	12.79295043
FE 1 GROUP 1	Spline Z5:	W1	16.36698651
FE 1 GROUP 1	Spline Z6:	W2	21.21154942
FE 1 GROUP 1	Spline Z7:	W2	20.9553372
FE 1 GROUP 1	Spline Z8:	W2	23.14759292
FE 1 GROUP 1	Spline Z9:	W2	35.12932019
FE 1 GROUP 1	Spline Z10:	W2	40.27528353
FE 1 GROUP 1	Spline Z11:	W3	74.61741419
FE 1 GROUP 1	Spline Z12:	W3	52.56338947
FE 1 GROUP 1	Spline Z13:	W3	57.21101282
FE 1 GROUP 1	Spline Z14:	W3	0
FE 1 GROUP 1	Spline Z15:	W3	0
FE 1 GROUP 1	Spline Z16:	W4	0
FE 1 GROUP 1	Spline Z17:	W4	0
FE 1 GROUP 1	Spline Z18:	W4	0
FE 1 GROUP 1	Spline Z19:	W4	0
FE 1 GROUP 1	Spline Z20:	W4	0
FE 1 GROUP 1	Spline Z21:	W5	0
FE 1 GROUP 1	Spline Z22:	W5	0
FE 1 GROUP 1	Spline Z23:	W5	0
FE 1 GROUP 1	Spline Z24:	W5	0
FE 1 GROUP 1	Spline Z25:	W5	0
FE 1 GROUP 1	Spline Z26:	W6	0
FE 1 GROUP 1	Heater_Selection:	CB	0
FE 1 GROUP 1	VD Htr DAC Low:	CB	33178
FE 1 GROUP 1	VD Htr DAC High:	CB	34386
FE 1 GROUP 1	Act Exc DAC:	CB	13107
FE 1 GROUP 1	Ref Exc DAC:	CB	13107
FE 1 GROUP 1	Max Heater Ohms:	HP	115
FE 1 GROUP 1	Heater Shorted Ohms:	AO	70
FE 1 GROUP 1	Heater Open Ohms:	AO	150
FE 1 GROUP 1	Fatal Fault Map:	FT	123076484
FE 1 GROUP 1	Sensor Type 1=100Ω, 4=1KΩ:	SC	4
FE 1 GROUP 1	AST Pwr Mode 0=cdT 1=cPwr:	CE	1
FE 1 GROUP 1	dT/go to max:	VC	0
FE 1 GROUP 1	TW_Diam:	L2	0.003175
FE 1 GROUP 1	TW_Length:	L3	0.01778
FE 1 GROUP 1	K_base_70F:	GF	0.02573

Destination	Parameter Name	CLI	Parameter Value
FE 1 GROUP 1	K_exp:	GF	1
FE 1 GROUP 1	K_tc:	GF	0.63
FE 1 GROUP 1	lowdTdR:	GF	0
FE 1 GROUP 1	MaxTCAdder:	GF	1
FE 1 GROUP 1	R3dTdR:	GF	0
FE 1 GROUP 1	MaxExpAdder:	GF	1
FE 1 GROUP 1	CalGasNum:	GB	0
FE 1 CAL GAS 0	CalGasName:	A&	cal air
FE 1 CAL GAS 0	StdDensity:	A@	1.2
FE 1 CAL GAS 0	SpecificHeat:	A@	1600
FE 1 CAL GAS 0	ThermCon:	A@	0.02439
FE 1 CAL GAS 0	AbsViscosity:	A@	1.778E-05
FE 1 CAL GAS 0	KCal1:	A\$	-0.0003906894
FE 1 CAL GAS 0	KCal2:	A\$	0.0001057132
FE 1 CAL GAS 0	KCal3:	A\$	-6.644107E-08
FE 1 CAL GAS 0	KCal4:	A\$	3.001559E-11
FE 1 CAL GAS 0	KCal5:	A\$	0.025728284
FE 1 CAL GAS 0	CpCal1:	A#	1.035435
FE 1 CAL GAS 0	CpCal2:	A#	-0.0002799995
FE 1 CAL GAS 0	CpCal3:	A#	6.72945E-07
FE 1 CAL GAS 0	CpCal4:	A#	-2.736708E-10
FE 1 CAL GAS 0	CpCal5:	A#	1.004338956
FE 1 CAL GAS 0	uCal1:	A%	8.270382E-07
FE 1 CAL GAS 0	uCal2:	A%	7.250082E-08
FE 1 CAL GAS 0	uCal3:	A%	-5.165997E-11
FE 1 CAL GAS 0	uCal4:	A%	2.116171E-14
FE 1 CAL GAS 0	uCal5:	A%	1.82272E-05
FE 1 GROUP 1	CustGasNum:	GC	0
FE 1 CUST GAS 0	CustGasName:	A&	customer air
FE 1 CUST GAS 0	StdDensity:	A@	1.2
FE 1 CUST GAS 0	SpecificHeat:	A@	1600
FE 1 CUST GAS 0	ThermCon:	A@	0.02439
FE 1 CUST GAS 0	AbsViscosity:	A@	1.778E-05
FE 1 CUST GAS 0	KCust1:	A\$	-0.0003906894
FE 1 CUST GAS 0	KCust2:	A\$	0.0001057132
FE 1 CUST GAS 0	KCust3:	A\$	-6.644107E-08
FE 1 CUST GAS 0	KCust4:	A\$	3.001559E-11
FE 1 CUST GAS 0	KCust5:	A\$	0.025728284
FE 1 CUST GAS 0	CpCust1:	A#	1.035435
FE 1 CUST GAS 0	CpCust2:	A#	-0.0002799995
FE 1 CUST GAS 0	CpCust3:	A#	6.72945E-07
FE 1 CUST GAS 0	CpCust4:	A#	-2.736708E-10
FE 1 CUST GAS 0	CpCust5:	A#	1.004338956
FE 1 CUST GAS 0	uCust1:	A%	8.270382E-07
FE 1 CUST GAS 0	uCust2:	A%	7.250082E-08
FE 1 CUST GAS 0	uCust3:	A%	-5.165997E-11
FE 1 CUST GAS 0	uCust4:	A%	2.116171E-14
FE 1 CUST GAS 0	uCust5:	A%	1.82272E-05

**HMI Menu Outline**

- **Boot Screen**
- **Process Data Screen**
  - Percentage of Flow
  - Flowrate
  - Totalizer
  - Temperature
  - Pressure
  - Group
  - Group Name
- **Service**
  - **Select Group**
    - Password
      - ▣ 1: [group name]
      - ▣ 2: [group name]
      - ▣ 3: [group name]
      - ▣ 4: [group name]
      - ▣ 5: [group name]
  - **Alarm Ack**
    - [alarm ACK list]
  - **Diagnostics**
    - Show Faults
      - ▣ [fault codes list]
    - Self Test
      - ▣ FE 1 IDR
        - Password
    - Raw Signal
      - ▣ FE1
        - F1 Raw Signal
          - RefR: [value]
          - dR: [value]
          - dTdR: [value]
          - Temp: [value]
          - Flow: [value]
- **Set-up**
  - Instrument
    - ▣ Group 'X' [current active group]
      - Flow: [eng units]
      - Temp: [Deg F or Deg C]
      - Pres: N/A
      - Name: [group name]
      - Restore
      - Pipe: [Round or Rect.]
      - W: [dimension, inch]
      - H: [dimension, inch]
  - Display
    - ▣ Orientation
      - [select display orientation]
    - ▣ Contrast
      - [select display contrast]
  - Language
    - ▣ English
- **SDcard N/A**
  - Remove
  - Inserted
- **Device**
  - Serial No: [ser. no]
  - Sales Ord No: [sales ord. no.]
  - Software version [ver. no.]
- **FE Control**
  - FE1: [Online or Offline]
    - ▣ Password
      - FE1 Control
        - Online
        - Offline

**ST80/ST80L Configuration Software Menu Outline (v3.2.0.x)****ST80/ST80L Configuration Application**■ **ST80/ST80L**● **PROCESS DATA (IN CUSTOMER UNITS)**

- *FLOW (display)*
- *TEMPERATURE (display)*
- *CALIBRATION GROUP (display)*
- *ALARMS AND FAULTS (display)*

● **BASIC SETUP**

- Groups
- Units
- Pipe Size
- Alarms
- Totalizer
- Display Settings

● **ADVANCED SETUP**

- User Parameters
- Date and Time
- Download Calibration
- Reboot Device
- Flow Filtering

● **CONFIGURATION**

- Output
- 4-20mA User
- Modbus
- AST Power Mode

● **DIAGNOSTICS**

- Status
- Fault Log
- idR Scheduled Tasks
- idR Test Logs
- Heater Values

● **FACTORY**

- Factory Parameters
- Identification
- 4-20mA Factory
- Options
- HART
- Memory
- Reset idRs
- SIL Adj
- FE Faults
- Core Faults

■ **FE 1**● **PROCESS DATA**■ **Parameter Reports**

- **GROUP 1 (SCROLLABLE WINDOW)**
- **GROUP 2 (SCROLLABLE WINDOW)**
- **GROUP 3 (SCROLLABLE WINDOW)**
- **GROUP 4 (SCROLLABLE WINDOW)**
- **GROUP 5 (SCROLLABLE WINDOW)**

**Instructions: Installing Sun Shield on ST80/ST80L Integral Enclosure**

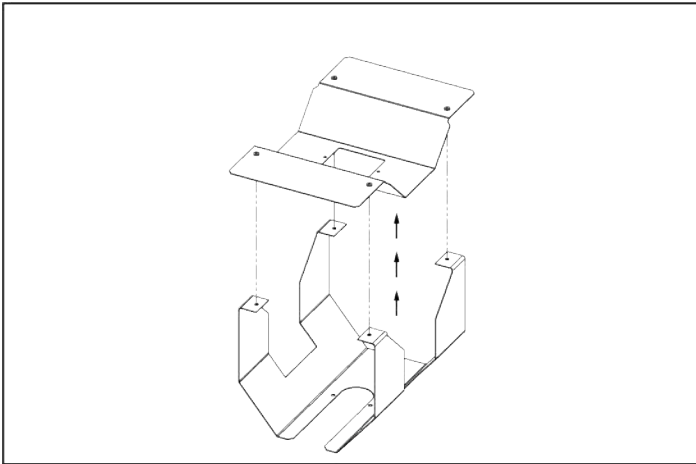

Step 1. Remove top of sun shield assembly.

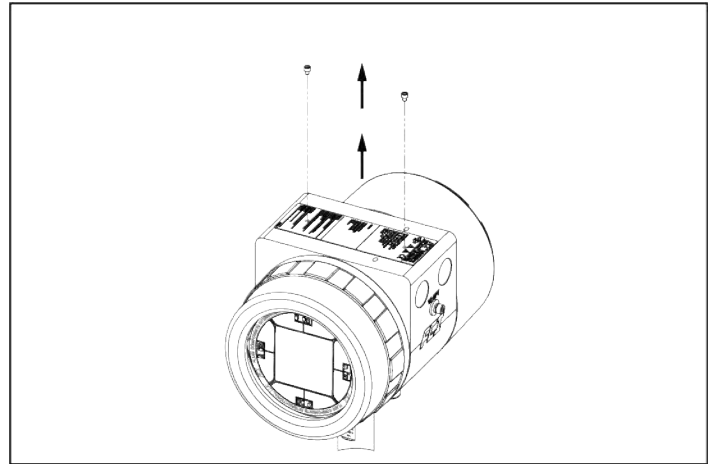

Step 2. Remove existing tag screws.

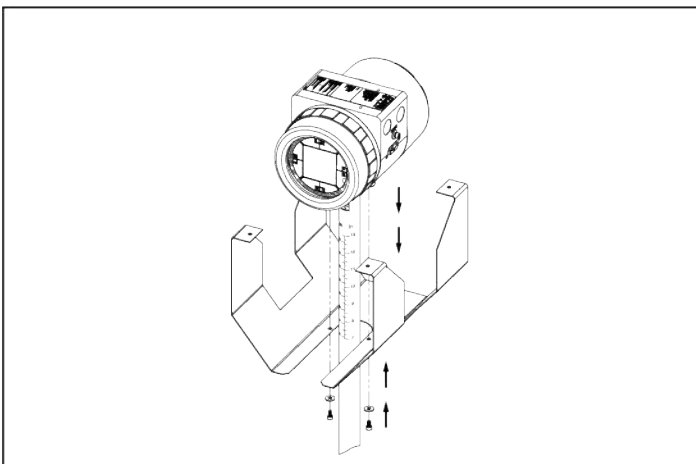

Step 3. Attach enclosure to lower portion of sun shield using supplied screws and washers.

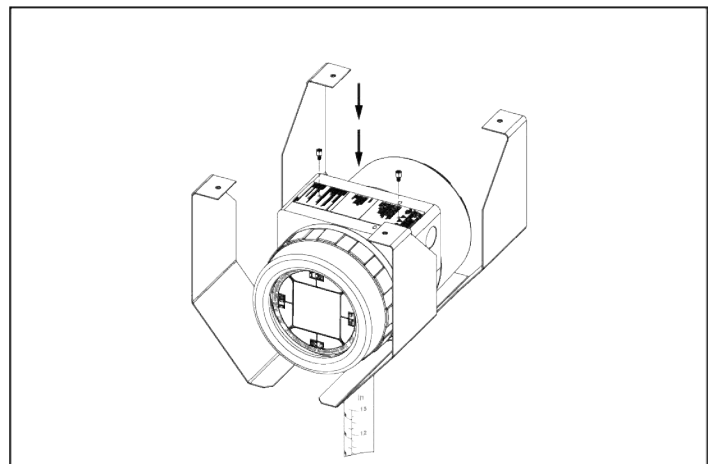

Step 4. Secure tag using supplied hex standoffs.

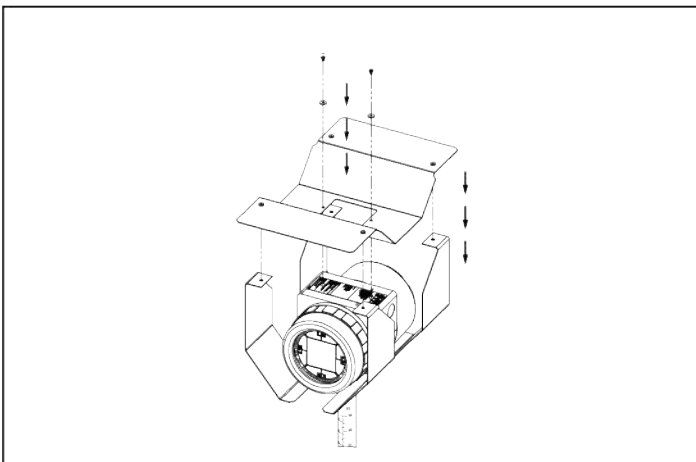

Step 5. Reinstall top portion of sun shield using supplied pan head screws and washers.

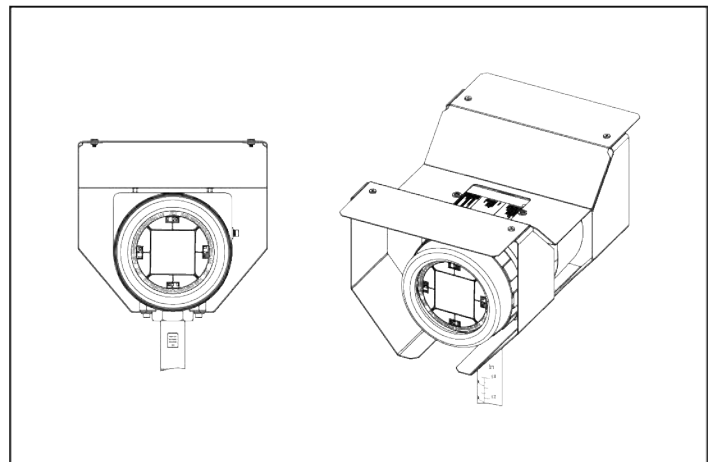

Step 6. Finished assembly – front and isometric views.

**Instructions: Installing Sun Shield on ST80/ST80L Remote Enclosure**

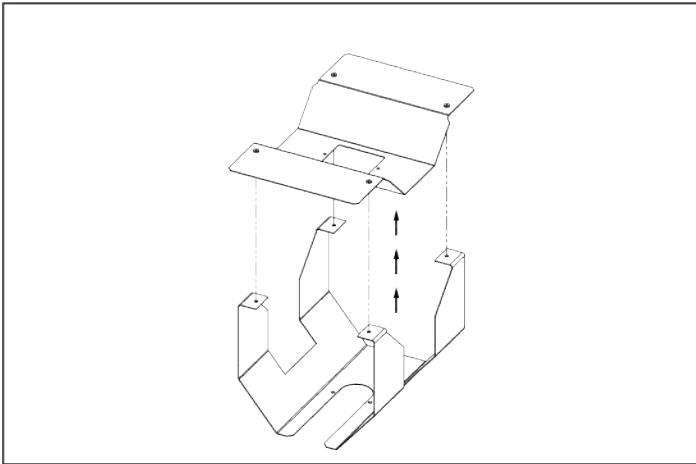

Step 1. Remove top of sun shield assembly.

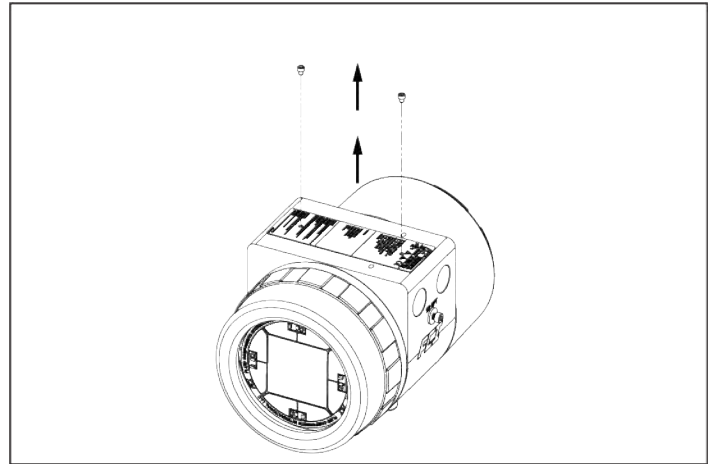

Step 2. Remove existing tag screws.

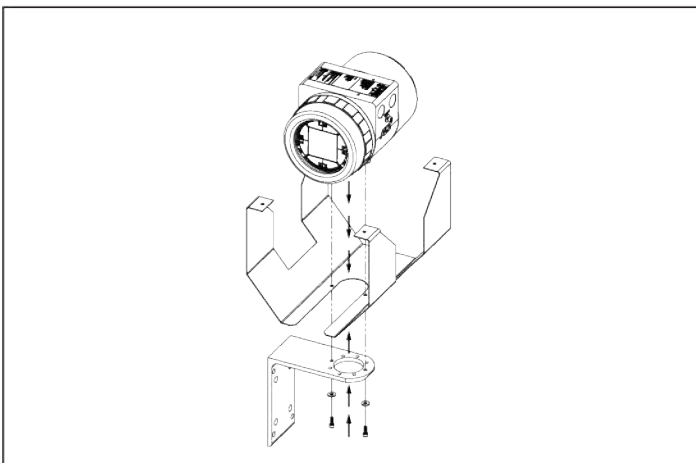

Step 3. Attach enclosure and lower portion of sun shield to remote bracket using supplied screws and washers. (Choose bracket hole pair that provides best instrument viewing angle in installed location.)

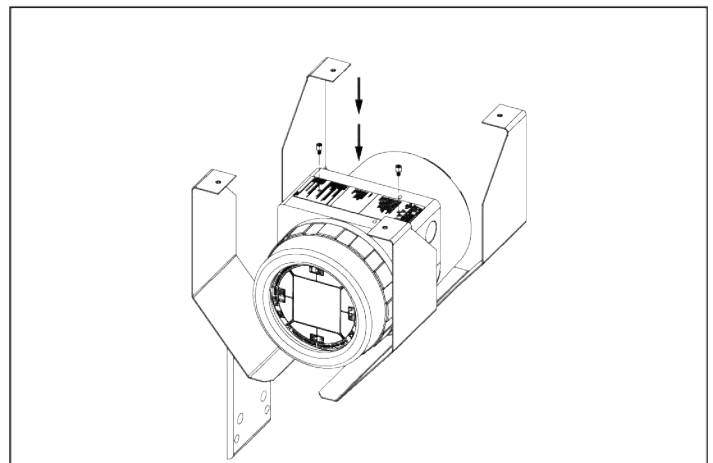

Step 4. Secure tag using supplied hex standoffs.

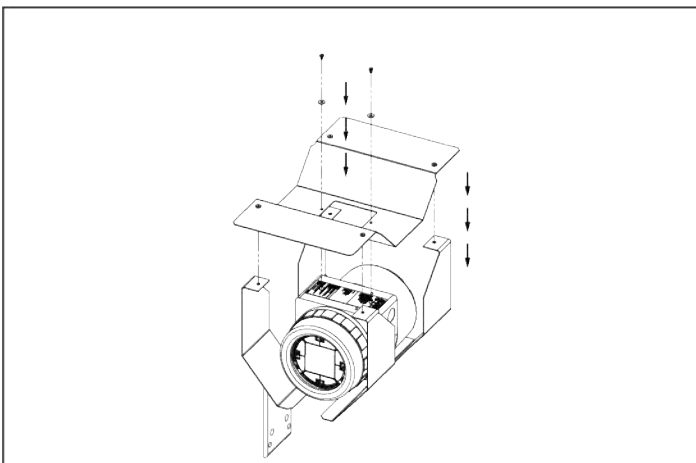

Step 5. Reinstall top portion of sun shield using supplied pan head screws and washers.

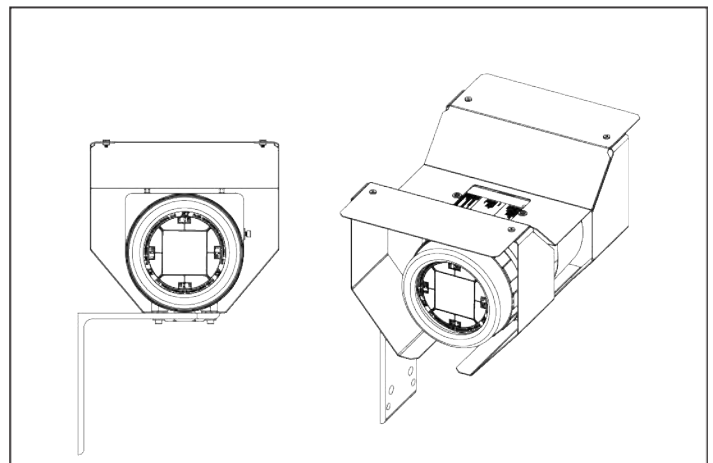

Step 6. Finished assembly – front and isometric views.

## APPENDIX C GLOSSARY

### Abbreviations

<b>AST</b>	Adaptive Sensing Technology
<b>Delta-R (<math>\Delta R</math>)</b>	Resistance differential
<b>Delta-T (<math>\Delta T</math>)</b>	Temperature differential
<b>DMM</b>	Digital Multimeter
<b>ESD</b>	Electrostatic discharge
<b>FCI</b>	Fluid Components International
<b>HTR</b>	Heater
<b>GND</b>	Ground
<b>LCD</b>	Liquid crystal display
<b>LED</b>	Light Emitting Diode
<b>OIS</b>	Ordering Information Sheet
<b>RTD</b>	Resistance Temperature Detector

### Definitions

<b>Active RTD</b>	The flow element part that senses the fluid flow rate.
<b>Adaptive Sensing Technology (AST)</b>	An FCI exclusive flow measurement technique that combines both constant Delta T and constant power measuring techniques in a single device.
<b>Resistance Differential Delta-R (<math>\Delta R</math>)</b>	The difference in resistance between the active and reference RTDs.
<b>Temperature Differential Delta-T (<math>\Delta T</math>)</b>	The difference in temperature between the active and reference RTDs.
<b>Flow Transmitter</b>	The portion of the flow meter that conditions, converts and scales the flow signal.
<b>Heater (HTR)</b>	The flow element part that heats the active RTD.
<b>Local Enclosure</b>	The enclosure attached to the flow element (usually contains the wiring terminal block).
<b>Reference Flat</b>	A flat part on the sensor head that helps to orient the sensor head to the flow.
<b>Reference RTD</b>	The flow element part that senses the fluid temperature.
<b>Remote Enclosure</b>	The enclosure that houses the flow transmitter remotely from the sensor head.
<b>Resistance Temperature Detector (RTD)</b>	A sensor whose resistance changes proportionally to temperature changes.
<b>Sensing Element</b>	The transducer portion of the instrument. The sensing element produces an electrical signal that is related to the flow rate, density (level sensing), and temperature of the process media.
<b>Thermowell</b>	The flow element part that protects the heater and RTDs from the process media.
<b>Turndown</b>	The ratio of minimum flow rate to maximum flow rate.

This Page Intentionally Left Blank



## APPENDIX D APPROVAL INFORMATION

### EU Information



### EU DECLARATION OF CONFORMITY ST80 SERIES

We, *Fluid Components International LLC*, located at 1755 La Costa Meadows Drive, San Marcos, California 92078-5115 USA, declare under our sole responsibility that the **ST80 Flowmeter Product Family**, to which this declaration relates, is in conformity with the following directives and specifications.

#### Directive 2014/34/EU ATEX

Certified by FM Approvals Europe LTD, (2809): One George Quay Plaza, D02 E440, Dublin, Ireland

EU-Type Examination Certificate:

FM18ATEX0064X satisfies EN IEC 60079-0:2018, EN 60079-1:2014, EN 60079-31: 2014, EN 60529:1991 +A1:2000 +A2:2013 requirements for use in hazardous areas.

Hazardous Areas Approval FM18ATEX0064X for:

II 2 G Ex db IIC T6...T1 Gb Ta = -40°C to +60°C; IP66/IP67

II 2 D Ex tb IIIC T85°C...T450°C Db Ta = -40°C to +60°C; IP66/IP67

#### Directive 2014/30/EU Electromagnetic Compatibility EMC

Immunity specification: EN 61000-6-2: 2005

Emissions specification: EN 61000-6-4: 2007, +A1: 2011

#### Directive 2014/35/EU Low Voltage

Electrical Safety Specification: EN 61010-1: 2010 +C1: 2011 + C2: 2013

#### Directive 2014/68/EU Pressure Equipment (PED)

The ST80 (Insertion Style) models do not have a pressure bearing housing and are therefore not considered as pressure equipment by themselves according to article 2, paragraph 5.

The ST80L (In-line Style) models are in conformity with Sound Engineering Practices as defined in the Pressure Equipment Directive (PED) 2014/68/EU article 4, paragraph 3.

#### Directive 2011/65/EU RoHS 2

The ST80 Product Family is in conformity with Directive 2011/65/EU of the European Parliament and of the Council of 8 June 2011 on the restriction of the use of certain hazardous substances in electrical and electronic equipment.

*Issued at San Marcos, California USA*

*August 2019*

 Eric Wible  
2019.08.27 08:39:58  
-07'00'

Eric Wible, Director of Engineering

Flow/Liquid Level/Temperature Instrumentation

Visit FCI on the Worldwide Web: [www.fluidcomponents.com](http://www.fluidcomponents.com)

1755 La Costa Meadows Drive, San Marcos, California 92078 USA 760-744-6950 • 800-854-1993 • 760-736-6250  
European Office: Persephonestraat 3-01 5047 TTTilburg – The Netherlands – Phone 31-13-5159989 • Fax 31-13-5799036

Doc no. 23EN000041B

**Safety Instructions****Safety Instructions for the use of the ST80/ST80L flow meter in Hazardous Areas****Approval FM18ATEX0064X / IECEx FMG 18.0025X for:****Gas protection: II 2 G Ex db T6...T1 Gb****Dust protection: II 2 D Ex tb T85°C...T450°C Db IP66/IP67**

The ST80/ST80L consists of a sensing element and associated integral or remote mounted electronics mounted in a type “d” flameproof enclosure.

Relation between ambient temperature, process temperature and temperature class is as follows:

**AST Setting****Integral Configuration** (Ta = Ambient Temperature, Tp = Process Temperature)

T4|T135°C: -40°C &lt; Ta &lt; +60°C / -40°C &lt; Tp &lt; +89°C

T3|T200°C: -40°C &lt; Ta &lt; +60°C / -40°C &lt; Tp &lt; +154°C

T2|T300°C: -40°C &lt; Ta &lt; +60°C / -40°C &lt; Tp &lt; +254°C

**Remote Configuration** (Ta = Ambient Temperature, Tp = Process Temperature)*Remote Electronics Enclosure*

T6|T85°C: -40°C &lt; Ta &lt; +40°C

T5|T100°C: -40°C &lt; Ta &lt; +55°C

T4|T135°C: -40°C &lt; Ta &lt; +60°C

*Local Enclosure and Sensor*

T4|T135°C: -40°C &lt; Ta &lt; +60°C / -40°C &lt; Tp &lt; +89°C

T3|T200°C: -40°C &lt; Ta &lt; +60°C / -40°C &lt; Tp &lt; +154°C

T2|T300°C: -40°C &lt; Ta &lt; +60°C / -40°C &lt; Tp &lt; +254°C

T1|T450°C: -40°C &lt; Ta &lt; +60°C / -40°C &lt; Tp &lt; +404°C

**Constant Power Setting****Integral Configuration** (Ta = Ambient Temperature, Tp = Process Temperature)

T4|T135°C: -40°C &lt; Ta &lt; +60°C / -40°C &lt; Tp &lt; +57°C

T3|T200°C: -40°C &lt; Ta &lt; +60°C / -40°C &lt; Tp &lt; +122°C

T2|T300°C: -40°C &lt; Ta &lt; +60°C / -40°C &lt; Tp &lt; +222°C

**Remote Configuration** (Ta = Ambient Temperature, Tp = Process Temperature)*Remote Electronics Enclosure*

T6|T85°C: -40°C &lt; Ta &lt; +40°C

T5|T100°C: -40°C &lt; Ta &lt; +55°C

T4|T135°C: -40°C &lt; Ta &lt; +60°C

*Local Enclosure and Sensor*

T4|T135°C: -40°C &lt; Ta &lt; +60°C / -40°C &lt; Tp &lt; +57°C

T3|T200°C: -40°C &lt; Ta &lt; +60°C / -40°C &lt; Tp &lt; +122°C

T2|T300°C: -40°C &lt; Ta &lt; +60°C / -40°C &lt; Tp &lt; +222°C

T1|T450°C: -40°C &lt; Ta &lt; +60°C / -40°C &lt; Tp &lt; +372°C

Electrical data: Power supply: 100 – 240 VAC, 50/60 Hz, 10 watts max.; 19.2 – 28.8 VDC, 9.6 watts max.

Dansk	Sikkerhedsforskrifter	Italiano	Normative di sicurezza
Deutsch	Sicherheitshinweise	Nederlands	Veiligheidsinstructies
English	Safety instructions	Português	Normas de segurança
Ελληνικά	Υποδείξεις ασφαλείας	Español	Instrucciones de seguridad
Suomi	Turvallisuusohjeet	Svenska	Säkerhetsanvisningar
Français	Consignes de sécurité		

## **DK** Dansk - Sikkerhedsforskrifter

Disse sikkerhedsforskrifter gælder for Fluid Components, gennemstrømningsmåleren i ST80/ST80L for EF-typeafprøvningsattest-nr. FM18ATEX0064X / IECEx FMG 18.0025X (attestens nummer på typeskiltet) til anvendelse i en potentiel eksplosiv atmosfære i kategori II 2 GD.

- 1) Ex-anlæg skal opstilles af specialiseret personale.
- 2) ST80/ST80L skal jordforbindes.
- 3) Klemmerne og elektronikken er monteret i et hus, som er beskyttet af en flammebestandig og tryktæt med følgende noter:
  - Gevindspalten mellem huset og låget er på en sådan måde, at ild ikke kan brede sig inden i det.
  - Ex-"d" tilslutningshuset er forsynet med et 1/2" NPT eller M20x1.5 kabelindføring til montering af en Ex-"d" kabelindføring, der er attesteret iht. IEC/EN 60079-1.
  - Det er vigtigt at sørge for, at forsyningsledningen er uden spænding eller eksplosiv atmosfære ikke er til stede, før låget åbnes og når låget er åbent på "d" huset (f.eks. ved tilslutning eller servicearbejde).
  - Låget på "d" huset skal være skruet helt ind, når apparatet er i brug. Det skal sikres ved at dreje en af låseskruerne på låget ud.
- 4) Henvend dig til producenten, hvis du har brug for oplysninger om målerne på de flammebestandige led.
- 5) Den maledede overflade på gennemstrømningsmåleren i ST80/ST80L kan indeholde elektrostatisk udladning og blive en antændelseskilde ved anvendelser med en lav relativ fugtighed < 30 % relativ fugtighed, hvis den maledede overflade er relativt fri for overfladekontaminanter, som fx snavs, støv eller olie. Rengøring af den maledede overflade må kun udføres med en fugtig klud.
- 6) Det interne batteri må ikke udskiftes i en eksplosiv gasholdig atmosfære.

## **D A** Deutsch - Sicherheitshinweise

Diese Sicherheitshinweise gelten für die Fluid Components, ST80/ST80L flow meter gemäß der EG-Baumusterprüfbescheinigung Nr. FM18ATEX0064X / IECEx FMG 18.0025X (Bescheinigungsnummer auf dem Typschild) der Kategorie II 2 GD.

- 1) Die Errichtung von Ex-Anlagen muss grundsätzlich durch Fachpersonal vorgenommen werden.
- 2) Der ST80/ST80L muß geerdet werden.
- 3) Die Klemmen und Elektronik sind in einem Gehäuse in der Zündschutzart druckfeste Kapselung („d“) eingebaut.
  - Der Gewindespalt zwischen dem Gehäuse und dem Deckel ist ein zünddurchschlagsicherer Spalt.
  - Das Ex-"d" Anschlussgehäuse besitzt ein 1/2" NPT oder M20x1.5 Gewinde für den Einbau einer nach IEC/EN 60079-1 bescheinigten Ex-"d" Kabeleinführung.
  - Es ist sicherzustellen, dass vor dem Öffnen und bei geöffnetem Deckel des „d“ Gehäuses (z.B. bei Anschluss oder Service- Arbeiten) entweder die Versorgungsleitung spannungsfrei oder keine explosionsfähige Atmosphäre vorhanden ist.
  - Der Deckel des "d" Gehäuses muss im Betrieb bis zum Anschlag hineingedreht sein. Er ist durch eine der Deckelarretierungsschrauben zu sichern.
- 4) Wenden Sie sich an den Hersteller, wenn die Dimensionsinformationen zu den flammbeständigen Spalten erforderlich sind.
- 5) Die lackierte Oberfläche des ST80/ST80L flow meter kann elektrostatisch aufgeladen sein und in Anwendungen mit einer niedrigen relativen Feuchtigkeit von weniger als 30 %, bei denen die lackierte Oberfläche relativ frei von Flächenverunreinigungen wie Schmutz, Staub oder Fett ist, zu einer Zündquelle werden. Die lackierte Oberfläche sollte nur mit einem feuchten Tuch gereinigt werden.
- 6) Ersetzen Sie die interne Batterie nicht in einer explosionsfähigen Gasatmosphäre.

## **GB IRL** English - Safety instructions

These safety instructions are valid for the Fluid Components, ST80/ST80L flow meter to the EC type approval certificate no FM18ATEX0064X / IECEx FMG 18.0025X (certificate number on the type label) for use in potentially explosive atmospheres in Category II 2 GD.

- 1) The installation of Ex-instruments must be made by trained personnel.
- 2) The ST80/ST80L must be grounded.
- 3) The terminals and electronics are installed in a flame proof and pressure-tight housing with following notes:
  - The gap between the housing and cover is an ignition-proof gap.
  - The Ex-"d" housing connection has a 1/2" NPT or M20x1.5 cable entry for mounting an Ex-d cable entry certified acc. to IEC/EN 60079-1.
  - Make sure that before opening the cover of the Ex"d" housing, the power supply is disconnected or there is no explosive atmosphere present (e.g. during connection or service work).
  - During normal operation: The cover of the "d" housing must be screwed in completely and locked by tightening one of the cover locking screws.
- 4) Consult the manufacturer if dimensional information on the flameproof joints is necessary.
- 5) The painted surface of the ST80/ST80L flow meter may store electrostatic charge and become a source of ignition in applications with a low relative humidity < 30% relative humidity where the painted surface is relatively free of surface contamination such as dirt, dust, or oil. Clean the painted surface using a damp cloth only.
- 6) Do not replace internal battery when an explosive gas atmosphere is present.

## GR Ελληνικά - Υποδείξεις ασφαλείας

Αυτές οι οδηγίες ασφαλείας ισχύουν για τα ροόμετρα της Fluid Components τύπου ST80/ST80L που φέρουν Πιστοποιητικό Εγκρίσεως Ευρωπαϊκής Ένωσης, με αριθμό πιστοποίησης FM18ATEX0064X / IECEx FMG 18.0025X (ο αριθμός πιστοποίησης βρίσκεται πάνω στην ετικέτα τύπου του οργάνου) για χρήση σε εκρηκτικές ατμόσφαιρες της κατηγορίας II 2 GD.

- 1) Η εγκατάσταση των οργάνων με αντικρηκτική προστασία πρέπει να γίνει από εξειδικευμένο προσωπικό.
- 2) Το όργανο τύπου ST80/ST80L πρέπει να είναι γειωμένο.
- 3) Τα θερματικά ηλεκτρικών συνδέσεων (κλέμες) και τα ηλεκτρονικά κυκλώματα είναι εγκατεστημένα σε περιβλήμα αντικρηκτικό και αεροστεγές σύμφωνα με τις ακόλουθες παρατηρήσεις:
  - Το κενό ανάμεσα στο περίβλημα και στο κάλυμμα είναι τέτοιο που αποτρέπει την διάδοση σπινθήρα.
  - Το αντικρηκτικό περίβλημα "Ex-d" διαθέτει ανοίγματα εισόδου καλωδίου με διάμετρο 1/2" NPT ή M 20 x1,5 , κατάλληλα για τοποθέτηση υποδοχής αντικρηκτικού καλωδίου πιστοποιημένου κατά IEC/EN 60079-1
  - Βεβαιωθείτε ότι πριν ανοίξετε το κάλυμμα του αντικρηκτικού περιβλήματος "Ex-d", η τάση τροφοδοσίας είναι αποσυνδεδεμένη ή ότι δεν υφίσταται στην περιοχή εκρηκτική ατμόσφαιρα (π.χ. κατά τη διάρκεια της σύνδεσης ή των εργασιών συντήρησης)
  - Κατά τη διάρκεια ομαλής λειτουργίας: Το κάλυμμα του αντικρηκτικού περιβλήματος "d" πρέπει να είναι καλά βιδωμένο και ασφαλισμένο, σφίγγοντας μία από τις βίδες ασφαλείας του περιβλήματος.
- 4) Εάν απαιτούνται πληροφορίες για τις διαστάσεις των αντιπυρικών συνδέσμων, απευθυνθείτε στον κατασκευαστή.
- 5) Στην βαμμένη επιφάνεια του ροόμετρου ST80/ST80L ενδέχεται να δημιουργείται ηλεκτροστατική φόρτιση κι αυτό να αποτελεί πηγή ανάφλεξης κατά την εφαρμογή σε συνθήκες χαμηλής σχετικής υγρασίας (<30%) όπου η βαμμένη επιφάνεια είναι σχετικά ελεύθερη από ρύπανση, όπως ακαθαρσίες, σκόνη ή λάδια. Ο καθαρισμός της βαμμένης επιφάνειας πρέπει να πραγματοποιείται μόνο με νοτισμένο πανί.
- 6) Μην αντικαθιστάτε την εσωτερική μπαταρία σε ατμόσφαιρα με εκρηκτικά αέρια.

## FIN Suomi - Turvallisuusohjeet

Nämä turvallisuusohjeet koskevat Fluid Components, ST80/ST80L-virtausmittaria, tyyppitarkastustodistuksen nro. FM18ATEX0064X / IECEx FMG 18.0025X (todistuksen numero näkyy tyyppikilvestä) käytettäessä räjähdysvaarallisissa tiloissa luokassa II 2GD.

- 1) Ex-laitteet on aina asennettava ammattihenkilökunnan toimesta.
- 2) ST80/ST80L on maadoitettava.
- 3) Syöttöjännitteen kytkemisessä tarvittavat liittimet ja elektroniikka on asennettu koteloon, jonka rakenne kestää räjähdyspaineen seuraavin lisäyksin:
  - Kotelon ja kannen välissä on räjähdysten purkausväli.
  - Ex-d liittämätkotelossa on 1/2" NPT tai M20x1.5 kierre IEC/EN 60079-1 mukaisen Ex-d kaapeliäpiviennin asennusta varten
  - Kun "d"-kotelon kansi avataan (esim. liitäntän tai huollon yhteydessä), on varmistettava, että joko syöttöjohto on jännitteetön tai ympäristössä ei ole räjähtäviä aineita.
  - "d" -kotelon kansi on kierrettävä aivan kiinni käytön yhteydessä ja on varmistettava kiertämällä yksi kannen lukitusruuveista kiinni.
- 4) Mikäli räjähdyspaineen kestävästä liitoksista tarvitaan mittatietoja, ota yhteys valmistajaan.
- 5) ST80/ST80L-virtausmittarin maalatussa pinnassa saattaa olla sähköstaattista varausta, mikä voi aiheuttaa räjähdysten käyttökohteissa, joiden suhteellinen kosteus on alhainen eli alle 30 %, kun maalattulla pinnalla ei ole huomattavaa likaa, pölyä tai öljyä. Maalatus pinnan saa puhdistaa ainoastaan kostealla liinalla.
- 6) Älä vaihda sisäistä akkua kaasuräjähdysvaarallisissa tiloissa.

## F B L Français - Consignes de sécurité

Ces consignes de sécurité sont valables pour le modèle série ST80/ST80L de la société Fluid Components (FCI) conforme au certificat d'épreuves de type FM18ATEX0064X / IECEx FMG 18.0025X (numéro du certificat sur l'étiquette signalétique) conçu pour les applications dans lesquelles un matériel de la catégorie II2GD est nécessaire.

- 1) Seul un personnel spécialisé et qualifié est autorisé à installer le matériel Ex.
- 2) Les ST80/ST80L doivent être reliés à la terre.
- 3) Les bornes pour le branchement de la tension d'alimentation et l'électronique sont logées dans un boîtier à enveloppe antidéflagrante avec les notes suivantes :
  - Le volume entre le boîtier et le couvercle est protégé en cas d'amorçage.
  - Le boîtier de raccordement Ex-d dispose d'un filetage 1/2" NPT ou M20x1.5 pour le montage d'un presse-étoupe Ex-d certifié selon la IEC/EN 60079-1.
  - Avant d'ouvrir le couvercle du boîtier « d » et pendant toute la durée où il le restera ouvert (pour des travaux de raccordement, d'entretien ou de dépannage par exemple), il faut veiller à ce que la ligne d'alimentation soit hors tension ou à ce qu'il n'y ait pas d'atmosphère explosive.
  - Pendant le fonctionnement de l'appareil, le couvercle du boîtier « d » doit être vissé et serré jusqu'en butée. La bonne fixation du couvercle doit être assurée en serrant une des vis d'arrêt du couvercle.
- 4) Consulter le fabricant si les dimensions des joints ignifugés sont nécessaires.
- 5) La surface peinte du débitmètre série ST80/ST80L peut contenir une charge électrostatique et devenir une source d'inflammation pour les applications où l'humidité relative est faible (< 30 %) et où la surface peinte ne présente pas de souillures (poussière, saleté, huile). Les surfaces peintes ne doivent être nettoyées qu'à l'aide d'un chiffon humide.
- 6) Ne pas remplacer la batterie interne en présence d'un gaz explosif.

## I Italiano - Normative di sicurezza

Queste normative di sicurezza si riferiscono ai misuratori di portata serie ST80/ST80L della Fluid Components. Secondo il certificato CE di prova di omologazione n° FM18ATEX0064X / IECEx FMG 18.0025X (numero del certificato sulla targhetta d'identificazione), essi sono idonei all'impiego in atmosfere potenzialmente esplosive di categoria II 2 GD.

- 1) L'installazione di sistemi Ex deve essere eseguita esclusivamente da personale specializzato.
- 2) I misuratori serie ST80/ST80L devono essere collegati a terra.
- 3) I morsetti per il collegamento e l'elettronica sono incorporati in una custodia a prova di esplosione ("d") con le seguenti note:
  - L'interstizio tra la custodia e il coperchio è a prova di innesco.
  - La custodia di collegamento Ex-d è dotata di un NTP da 3,81 cm o un passacavo 20x1,5 per il montaggio di un passacavo omologato Ex-d secondo IEC/EN 60079-1.
  - Prima di aprire il coperchio della custodia "d" (per es. durante operazioni di collegamento o di manutenzione) accertarsi che l'apparecchio sia disinserito o che non si trovi in presenza di atmosfere esplosive.
  - Durante le operazioni ordinarie, il coperchio della custodia "d" deve essere avvitato e chiuso avvitando una delle viti di chiusura fino all'arresto.
- 4) Consultare il produttore per ottenere informazioni sulle dimensioni dei giunti non infiammabili.
- 5) La superficie pitturata del misuratore di portata serie ST80/ST80L potrebbe trattenere carica elettrostatica e diventare una fonte infiammabile in applicazioni con un'umidità relativa bassa < 30%, dove la superficie pitturata è relativamente libera da sostanze contaminanti come polvere, sporizia o olio. La superficie pitturata deve essere pulita esclusivamente con un panno umido.
- 6) Non sostituire la batteria interna in caso di presenza di gas esplosivi nell'atmosfera.

## NL B Nederlands - Veiligheidsinstructies

Deze veiligheidsinstructies gelden voor de flow meter uit de ST80/ST80L-serie van Fluid Components (FCI) overeenkomstig het EG-typegoedkeuringscertificaat met nummer FM18ATEX0064X / IECEx FMG 18.0025X (nummer van het certificaat op het typeplaatje) voor gebruik in een explosieve atmosfeer volgens Categorie II 2GD.

- 1) De installatie van Ex-instrumenten dient altijd te geschieden door geschoold personeel.
- 2) De ST80/ST80L-serie moet geaard worden.
- 3) De aansluitklemmen en de elektronica zijn ingebouwd in een drukvaste behuizing met de volgende opmerkingen:
  - De schroefdraadspleet tussen de behuizing en het deksel is een ontstekingsdoorslagveilige spleet.
  - De Ex-'d' aansluitbehuizing heeft een 1/2" of een M20x1.5 schroefdraad voor aansluiting van een volgens IEC/EN 60079-1 goedgekeurde Ex-'d' kabelinvoer.
  - De atmosfeer mag niet explosief zijn of de stroomtoevoer moet zijn uitgeschakeld, voordat het deksel van de Ex-'d' behuizing wordt geopend (bijvoorbeeld bij aansluit- of servicewerkzaamheden).
  - Het deksel van de 'd' behuizing moet bij normaal bedrijf zijn vastgeschroefd tot aan de aanslag. Het deksel moet zijn vergrendeld door een van de dekselborgschroeven aan te draaien.
- 4) Raadpleeg de fabrikant als u dimensionale informatie over de drukvaste verbindingen nodig hebt.
- 5) Er kan sprake zijn van een elektrostatische lading op het gelakte oppervlak van de flow meter uit de ST80/ST80L-serie. Deze lading kan een ontstekingsbron vormen bij toepassingen met een lage relatieve vochtigheid (< 30% relatieve vochtigheid), wanneer het gelakte oppervlak relatief weinig is verontreinigd met bijvoorbeeld vuil, stof of olie. Het gelakte oppervlak mag alleen worden gereinigd met een vochtige doek.
- 6) Vervang de interne accu niet in een explosieve gasatmosfeer.

## P Português - Normas de segurança

Estas instruções de segurança são válidas para o caudalímetro Fluid Components da série ST80/ST80L, de acordo com o certificado de aprovação n° FM18ATEX0064X / IECEx FMG 18.0025X (numero do certificado na etiqueta de tipo), para utilizar em atmosferas potencialmente explosivas da categoria II 2 GD.

- 1) A instalação de equipamentos Ex deve ser realizada por pessoal qualificado.
- 2) A Série ST80/ST80L tem de ser ligada à terra.
- 3) Os terminais e a eletrônica são instalados num alojamento com proteção contra ignição e estanque em termos de pressão com as seguintes notas:
  - A folga entre o alojamento e a tampa é uma folga à prova de ignição.
  - A ligação do alojamento Ex-"d" tem uma entrada de cabo de 1/2" NPT ou M20x1,5 para a montagem de um cabo Ex-"d" certificado de acordo com a norma IEC/EN 60079-1.
  - Assegure, antes de abrir a tampa do alojamento Ex "d", que a fonte de alimentação está desligada ou que não está presente uma atmosfera explosiva (por exemplo, durante o trabalho de ligação ou assistência).
  - Durante o funcionamento normal: a tampa do alojamento "d" deve estar completamente aparafusada e bloqueada apertando um dos parafusos de bloqueio da tampa.
- 4) Consulte o fabricante se for necessária informação sobre as dimensões das junções à prova de chamas.
- 5) A superfície pintada do caudalímetro da série ST80/ST80L pode acumular cargas eletrostáticas e tornar-se numa fonte de ignição em aplicações com uma humidade relativa baixa < 30%, onde a superfície pintada está relativamente livre de contaminação da superfície com, por exemplo, sujidade, poeira ou óleo. A limpeza da superfície pintada deverá ser efetuada apenas com um pano humedecido.
- 6) Não substitua a bateria interna quando estiver presente uma atmosfera com fases explosivos.

## **E** Español - Instrucciones de seguridad

Estas instrucciones de seguridad son de aplicación para el modelo Serie ST80/ST80L de Fluid Components, según la certificación CE de N° FM18ATEX0064X / IECEx FMG 18.0025X para aplicaciones en atmósferas potencialmente explosivas según la categoría II 2 GD (el número decertificación se indica sobre la placa informativa del equipo).

- 1) La instalación de equipos Ex tiene que ser realizada por personal especializado.
- 2) Los Serie ST80/ST80L deben ser conectados a tierra.
- 3) Los bornes de conexión y la unidad electrónica están montados dentro de una caja con protección ignífuga y resistente a la presión, considerándo los siguientes puntos:
  - La holgura entre la caja y su tapa es a prueba contra ignición.
  - La conexión eléctrica de la caja Ex-"d" posee una rosca NPT de 1/2" o una entrada de cable M20x1.5, dónde deberán conectar una entrada de cable Ex-"d" según lo establecido por las normas IEC/EN 60079-1.
  - Antes de la apertura de la tapa de la caja Ex-"d" (p. ej. durante los trabajos de conexión o de puesta en marcha), asegúrese de que el equipo se halle sin tensión o que no exista presencia de atmósfera explosiva.
  - Durante el funcionamiento normal: la tapa de la caja "d" tiene que estar cerrada, roscada hasta el tope, debiéndose asegurar apretando los tornillos de bloqueo.
- 4) Consulte con el fabricante si es necesario incluir la información dimensional en las juntas ignífugas.
- 5) Es posible que la superficie pintada del medidor de flujo Serie ST80/ST80L almacene carga electrostática y se convierta en una fuente de ignición en aplicaciones con baja humedad relativa < 30% cuando la superficie pintada está relativamente libre de contaminación en superficie, como por ejemplo suciedad, polvo o aceite. La limpieza de la superficie pintada debe realizarse solo con un paño húmedo.
- 6) No reemplace la batería interna cuando se encuentre en una atmósfera con presencia de gas explosivo.

## **S** Svenska - Säkerhetsanvisningar

Säkerhetsanvisningarna gäller för Fluid Componentets flödesmätare, typ ST80/ST80L, enligt EG-typgodkännandeintyg nr FM18ATEX0064X / IECEx FMG 18.0025X (intygsnumret återfinns på typskylten) för användning i explosiv gasblandning i kategori II 2 GD.

- 1) Installation av Ex-klassade instrument måste alltid utföras av fackpersonal.
- 2) ST80/ST80L måste jordas.
- 3) Anslutningsklämmorna och elektroniken är inbyggda i en explosions- och trycktät kapsling. Observera följande:
  - Spalten mellan kapslingen och lockets gänga är explosionstät.
  - Ex-d-kapslingen har en 1/2" NPT- eller M20x1,5-gänga för montering av en IEC/SS-EN 60079-1-typgodkänd Ex-d-kabelförskruvning
  - När Ex-d-kapslingens lock är öppet (t.ex. vid inkoppling - eller servicearbeten) ska man se till att enheten är spänningslös eller att ingen explosiv gasblandning förekommer.
  - Under drift måste Ex-d-kapslingens lock vara fastskruvat till anslaget. Skruva i en av lockets låskruvar för att låsa det. man i en av lockets insex låsskruvar.
- 4) Hör med tillverkaren om måttuppgifter om de brandsäkra fogarna behövs.
- 5) Den lackade ytan på ST80/ST80L-flödesmätaren kan lagra elektrostatisk laddning och bli en antändningskälla vid tillämpningar i en låg relativ luftfuktighet (< 30 %) om den lackade ytan i stort sett är ren från ytkontaminering som smuts, damm eller olja. Den lackade ytan får endast rengöras med en fuktad trasa.
- 6) Byt inte ut det interna batteriet om en explosiv atmosfär föreligger.

## APPENDIX E CUSTOMER SERVICE

### Customer Service/Technical Support

FCI provides full in-house technical support. Additional technical representation is also provided by FCI field representatives. Before contacting a field or in-house representative perform the troubleshooting techniques outlined in this document.

#### **By Mail**

Fluid Components International LLC  
1755 La Costa Meadows Dr.  
San Marcos, CA 92078-5115 USA  
Attn: Customer Service Department

#### **By Phone**

Contact the area FCI regional representative. If a field representative is unable to be contacted or if a situation is unable to be resolved, contact the FCI Customer Service Department toll free at 1 (800) 854-1993.

#### **By Fax**

To describe problems in a graphical or pictorial manner, send a fax including a phone or fax number to the regional representative. FCI is available by facsimile if all possibilities have been exhausted with the authorized factory representative. Our fax number is 1 (760) 736-6250; it is available 7 days a week, 24 hours a day.

#### **By Email**

FCI Customer Service can be contacted by email at: [techsupport@fluidcomponents.com](mailto:techsupport@fluidcomponents.com).

Describe the problem in detail making sure a telephone number and best time to be contacted is stated in the email.

#### **International Support**

For product information or product support outside the contiguous United States, Alaska, or Hawaii, contact your country's FCI International Representative or the one nearest to you.

#### **After Hours Support**

For product information visit FCI at [www.fluidcomponents.com](http://www.fluidcomponents.com). For product support call 1 (800) 854-1993 and follow the prerecorded instructions.

#### **Point of Contact**

The point of contact for service, or return of equipment to FCI is your authorized FCI sales/service office. To locate the office nearest you, visit the FCI website at [www.fluidcomponents.com](http://www.fluidcomponents.com).

#### **Warranty Repairs or Returns**

FCI prepays ground transportation charges for return of freight to the customer's door. FCI reserves the right to return equipment by the carrier of our choice.

International freight, handling charges, duty/entry fees for return of equipment are paid by the customer.

#### **Non-Warranty Repairs or Returns**

FCI returns repaired equipment to the customer either collect or prepaid and adds freight charges to the customer invoice.

#### **Extended Warranty**

An extended warranty is available. Contact the factory for details.

#### **Return to Stock Equipment**

The customer is responsible for all shipping and freight charges for equipment that is returned to FCI stock from the customer site. These items will not be credited to the customer's account until all freight charges are cleared, along with applicable return to stock charges, from the credit invoice. (Exceptions are made for duplicate shipments made by FCI.)

If any repair or return equipment is received at FCI, freight collect, without prior factory consent, FCI bills the sender for these charges.

**Field Service Procedures**

Contact an FCI field representative to request field service.

A field service technician is dispatched to the site from either the FCI factory or one of the FCI representative offices. After the work is complete, the technician completes a preliminary field service report at the customer site and leaves a copy with the customer.

Following the service call, the technician completes a formal, detailed service report. The formal report is mailed to the customer after the technician's return to the factory or office.

**Field Service Rates**

All field service calls are billed at the prevailing rates as listed in the FCI Price Book unless previous arrangements have been made with the FCI Customer Service Manager.

Customers are charged for all travel expenses including airfare, auto rental, meals and lodging. In addition, the customer shall pay all costs of transporting parts, tools or goods to and from the job site. Invoicing travel time, field service work and other expenses will be performed by FCI's Accounting Department.





1755 La Costa Meadows Drive, San Marcos, CA 92078-5115 USA  
760-744-6950 / 800-854-1993 / Fax: 760-736-6250  
Web Site: www.fluidcomponents.com  
E-mail: techsupport@fluidcomponents.com

RA # \_\_\_\_\_

### Return Authorization Request

**1. Return Customer Information**

Returning Company's Name: \_\_\_\_\_ Phone# \_\_\_\_\_  
Return Contact Name: \_\_\_\_\_ Fax # \_\_\_\_\_  
Email Address: \_\_\_\_\_

**2. Return Address**

Bill To: \_\_\_\_\_ Ship To: \_\_\_\_\_  
\_\_\_\_\_  
\_\_\_\_\_

**3. Mandatory End User Information**



Contact: \_\_\_\_\_ Company: \_\_\_\_\_ Country: \_\_\_\_\_

**4. Return Product Information**

Model No: \_\_\_\_\_ Serial No(s): \_\_\_\_\_  
Failure Symptoms (Detailed Description Required): \_\_\_\_\_  
\_\_\_\_\_  
What Trouble Shooting Was Done Via Phone or Field Visit by FCI: \_\_\_\_\_  
\_\_\_\_\_  
FCI Factory Technical Service Contact: \_\_\_\_\_

- 5. Reason For Return**     Sensor Element     Electronics     As Found Testing     Credit
- Recalibrate (New Data)     Recalibrate (Most Recent Data)     Other

(Note: A new Application Data Sheet (ADS) must be submitted for all recalibrations and re-certifications)

- 6. Payment Via**     Faxed Purchase Order          

(Note: A priced quotation is provided for all Non-Warranty repairs after equipment has been evaluated. All Non-Warranty repairs are subject to a minimum evaluation charge of \$250.00)

Factory Return Shipping Address:                      Fluid Components International LLC  
1755 La Costa Meadows Drive  
San Marcos, CA 92078-5115  
Attn: Repair Department  
RA # \_\_\_\_\_

FCI Document No. 05CS000004D [U]



The following Return Authorization Request form and Decontamination Statement **MUST be completed, signed and faxed back to FCI before** a Return Authorization Number will be issued. The signed Decontamination Statement and applicable MSDS Sheets **must be included with the shipment**. FCI will either fax, email or telephone you with the Return Authorization Number upon receipt of the signed forms.

**Packing Procedures**

1. **Electronics** should be wrapped in an **anti-static** or **static-resistant** bag, then wrapped in protective bubble wrap and surrounded with appropriate dunnage\* in a box. Instruments weighing **more than 50 lbs., or extending more than four feet**, should be secured in wooden crates by bolting the assemblies in place.
2. **The sensor head must be protected** with pvc tubing, or retracted the full length of the probe, locked and secured into the Packing Gland Assembly (cap screws tightened down).
3. FCI can supply crates for a nominal fee.
4. No more than **four (4)** small units packaged in each carton.
5. **FCI will not be held liable for damage caused during shipping.**
6. To ensure immediate processing **mark** the RA number on the outside of the box. Items without an RA number marked on the box or crate may be delayed.
7. **Freight must be "PrePaid"** to FCI receiving door.

\* Appropriate dunnage as defined by UPS, will protect package contents from a drop of 3 feet.

<p><b>*** Decontamination Statement *** This Section Must Be Completed ***</b></p>
<p>Exposure to hazardous materials is regulated by Federal, State, County and City laws and regulations. These laws provide FCI's employees with the "Right to Know" the hazardous or toxic materials or substances in which they may come in contact while handling returned products. Consequently, FCI's employees must have access to data regarding the hazardous or toxic materials or substances the equipment has been exposed to while in a customer's possession. Prior to returning the instrument for evaluation/repair, FCI requires thorough compliance with these instructions. The signer of the Certificate must be either a knowledgeable Engineer, Safety Manager, Industrial Hygenist or of similar knowledge or training and responsible for the safe handling of the material to which the unit has been exposed. <b>Returns without a legitimate Certification of Decontamination, and/or MSDS when required, are unacceptable and shall be returned at the customer's expense and risk.</b> Properly executed Certifications of Decontamination must be provided before a repair authorization (RA) number will be issued.</p>
<p><b>Certification Of Decontamination</b></p>
<p>I certify that the returned item(s) has(have) been thoroughly and completely cleaned. If the returned item(s) has(have) been exposed to hazardous or toxic materials or substances, even though it(they) has (have) been thoroughly cleaned and decontaminated, the undersigned attests that the attached Material Data Safety Sheet(s) (MSDS) covers said materials or substances completely. Furthermore, I understand that this Certificate, and providing the MSDS, shall not waive our responsibility to provide a neutralized, decontaminated, and clean product for evaluation/repair at FCI. Cleanliness of a returned item or acceptability of the MSDS shall be at the sole discretion of FCI. <b>Any item returned which does not comply with this certification shall be returned to your location Freight Collect and at your risk.</b></p>
<p><b>This certification must be signed by knowledgeable personnel responsible for maintaining or managing the safety program at your facility.</b></p>
<p>Process Flow Media _____</p>
<p>Product was or may have been exposed to the following substances: _____</p>
<p>Print Name _____</p>
<p>Authorized Signature _____ Date _____</p>
<p>Company Title _____</p>

Visit FCI on the Worldwide Web: [www.fluidcomponents.com](http://www.fluidcomponents.com)  
 1755 La Costa Meadows Drive, San Marcos, California 92078-5115 USA † Phone: 760-744-6950 † 800-854-1993 † Fax: 760-736-6250

FCI Document No. 05CS000004D [U]

### WARRANTIES

Goods furnished by the Seller are to be within the limits and of the sizes published by the Seller and subject to the Seller's standard tolerances for variations. All items made by the Seller are inspected before shipment, and should any of said items prove defective due to faults in manufacture or performance under Seller approved applications, or fail to meet the written specifications accepted by the Seller, they will be replaced or repaired by Seller at no charge to Buyer provided return or notice of rejection of such material is made within a reasonable period but in no event longer than one (1) year from date of shipment to Buyer, and provided further, that an examination by Seller discloses to Seller's reasonable satisfaction that the defect is covered by this warranty and that the Buyer has not returned the equipment in a damaged condition due to Buyer's or Buyer's employees', agents', or representatives' negligence and Buyer has not tampered, modified, redesigned, misapplied, abused, or misused the goods as to cause the goods to fail. In addition, this warranty shall not cover damage caused by Buyer's exposure of the goods to corrosive or abrasive environments. Moreover, Seller shall in no event be responsible for (1) the cost or repair of any work done by Buyer on material furnished hereunder (unless specifically authorized in writing in each instance by Seller), (2) the cost or repair of any modifications added by a Distributor or a third party, (3) any consequential or incidental damages, losses, or expenses in connection with or by reason of the use of or inability to use goods purchased for any purpose, and Seller's liability shall be specifically limited to free replacement, or refund of the purchase price, at Seller's option, provided return or rejection of the goods is made consistent with this paragraph, and the Seller shall in no event be liable for transportation, installation, adjustment, loss of good will or profits, or other expenses which may arise in connection with such returned goods, or (4) the design of products or their suitability for the purpose for which they are intended or used. Should the Buyer receive defective goods as defined by this paragraph, the Buyer shall notify the Seller immediately, stating full particulars in support of his claim, and should the Seller agree to a return of the goods, the Buyer shall follow Seller's packaging and transportation directions explicitly. In no case are the goods to be returned without first obtaining a return authorization from the Seller. Any repair or replacement shall be at Seller's factory, unless otherwise directed, and shall be returned to Seller transportation prepaid by Buyer. If the returned goods shall prove defective under this clause they will be replaced or repaired by Seller at no charge to Buyer provided the return or rejection of such material is made within a reasonable period, but in no event longer than (1) year from the date of shipment of the returned goods or the unexpired terms of the original warranty period whichever is later. If the goods prove to be defective under this paragraph, the Buyer shall remove the goods immediately from the process and prepare the goods for shipment to Seller. Continued use or operation of defective goods is not warranted by Seller and damage occurring due to continued use or operation shall be for Buyer's account. Any description of the goods contained in this offer is for the sole purpose of identifying them, and any such description is not part of the basis of the bargain, and does not constitute a warranty that the goods will conform to that description. The use of any sample or model in connection with this offer is for illustrative purposes only, is not part of the basis of the bargain, and is not to be construed as a warranty that the goods will conform to the sample or model. No affirmation of that fact or promise made by the Seller, whether or not in this offer, will constitute a warranty that the goods will conform to the affirmation or promise. THIS WARRANTY IS EXPRESSLY IN LIEU OF ANY AND ALL OTHER EXPRESS OR IMPLIED WARRANTIES WITH RESPECT TO THE GOODS OR THEIR INSTALLATION, USE, OPERATION, REPLACEMENT OR REPAIR, INCLUDING ANY IMPLIED WARRANTY OF MERCHANTABILITY OR FITNESS OF PURPOSE; AND THE GOODS ARE BEING PURCHASED BY BUYER "AS IS". SELLER WILL NOT BE LIABLE BY VIRTUE OF THIS WARRANTY OR OTHERWISE FOR ANY SPECIAL, INCIDENTAL OR CONSEQUENTIAL LOSS OR DAMAGE RESULTING FROM THE USE OR LOSS OF USE OF THE GOODS.



*Flow & Level Instrumentation  
Solutions for Industrial Processes*

**FCI's Complete Customer Commitment. Worldwide  
ISO 9001 and AS9100 Certified**

Visit FCI on the Worldwide Web: [www.fluidcomponents.com](http://www.fluidcomponents.com)

**FCI World Headquarters**

1755 La Costa Meadows Drive | San Marcos, California 92078 USA | Phone: 760-744-6950 Toll Free (US): 800-854-1993 Fax: 760-736-6250

**FCI Europe**

Persephonestraat 3-01 | 5047 TT Tilburg, The Netherlands | Phone: 31-13-5159989 Fax: 31-13-5799036

**FCI Measurement and Control Technology (Beijing) Co., LTD | [www.fluidcomponents.cn](http://www.fluidcomponents.cn)**

Room 107, Xianfeng Building II, No.7 Kaituo Road, Shangdi IT Industry Base, Haidian District | Beijing 100085, P. R. China  
Phone: 86-10-82782381 Fax: 86-10-58851152

**Notice of Proprietary Rights**

This document contains confidential technical data, including trade secrets and proprietary information which is the property of Fluid Components International LLC (FCI). Disclosure of this data to you is expressly conditioned upon your assent that its use is limited to use within your company only (and does not include manufacture or processing uses). Any other use is strictly prohibited without the prior written consent of FCI.