



## SERVOPRO MultiExact 4200 Analyzer

### Installation and Operator Manual

P/N: 0820000M



## **IMPORTANT INFORMATION**

*Continued safe and reliable operation of this equipment is conditional on all installation, operation and maintenance procedures being carried out in accordance with the appropriate manuals, by personnel having appropriate qualifications, experience and training. Failure to observe the requirements of the manual may result in the user being held responsible for the consequences and may invalidate any warranty. Servomex accepts no liability for unauthorized modifications to Servomex supplied equipment.*

*Servomex has paid particular attention to Health and Safety throughout this manual. Where special precautions need to be taken due to the nature of the equipment or product, an appropriate safety icon and warning message is shown. Special attention should be made to section 2 – Safety, where all such messages are summarized.*

*This document, and all specifications and drawings within the document, are the property of Servomex, unless agreed otherwise by contract. They must not be reproduced, copied or transmitted in any form, or by any means, or used as the basis for the manufacture or sale of apparatus, programs or services without permission.*

*In line with our continuous policy of research and development, we reserve the right to amend models and specifications without prior notice therefore the information in this document is subject to change without notice and does not represent a commitment on the part of Servomex Group Limited. This handbook is accurate at the date of printing but will be superseded and should be disregarded if specifications or appearance are changed. Check the internet for updates to the manual. The latest revision of this manual is available in Adobe Acrobat format at [www.servomex.com](http://www.servomex.com).*

*The customer agrees that in accepting and using this instrument Servomex's liability arising from or in any way connected with this instrument shall be limited exclusively to performing a new calibration or replacement or repair of the instrument or transducer, at Servomex's sole option, as covered by Servomex's warranty. In no event shall Servomex be liable for any incidental, consequential or special damages of any kind or nature whatsoever, including but not limited to lost profits arising from or in any way connected with this instrument or items hereunder, whether alleged to arise from breach of contract, express or implied warranty, or in tort, including without limitation, negligence, failure to warn or strict liability.*

*Servomex is a registered trademark of Servomex Group Inc. The use of all trademarks in this document is acknowledged.*

### **North America:**

Servomex Group Inc.  
4 Constitution Way  
Woburn MA 01801-1087  
United States

t: +1 781 935 4600

t: +1 800 433 2552 (US toll free)

e: [americas\\_sales@servomex.com](mailto:americas_sales@servomex.com)

w: [www.servomex.com](http://www.servomex.com)

### **Europe:**

Servomex Group Ltd  
Jarvis Brook  
Crowborough  
East Sussex TN6 3FB  
United Kingdom

t: + 44 (0) 1892 652 181

e: [europa\\_sales@servomex.com](mailto:europa_sales@servomex.com)

w: [www.servomex.com](http://www.servomex.com)

### **Representative:**

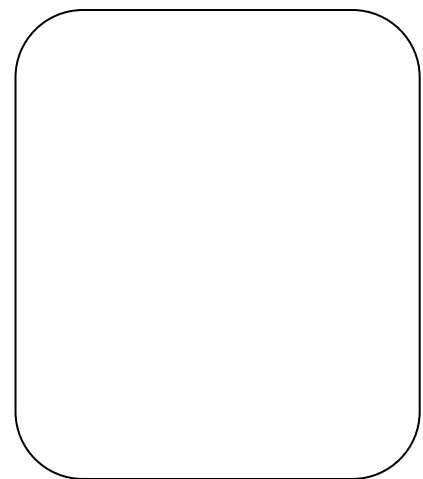

© 2021. Servomex Group Limited. A Spectris Company. All rights reserved

# Contents

<b>1</b>	<b>Revision: 0.9 Introduction</b>	<b>7</b>
1.1	About this manual	7
1.2	Applicable EU Directives, Standards, Certification	8
1.3	Product overview	9
1.4	General description	10
1.5	Recommended calibration intervals	11
1.6	Automatic calibration options	12
1.7	Product identification	13
1.8	Sample requirements	14
<b>2</b>	<b>Safety</b>	<b>16</b>
2.1	Appropriate environmental monitoring, ventilation and gas safety controls	16
2.2	Chemical & Flammability Warnings	18
2.3	System Considerations	18
2.4	Electrical warnings	19
2.5	Electromagnetic Compatibility (EMC) considerations	20
2.6	Markings	21
<b>3</b>	<b>Installation and set-up</b>	<b>23</b>
3.1	Unpacking	23
3.2	Mechanical Installation	24
3.3	Electrical installation	26
3.4	Sample / calibration gas connections	32
<b>4</b>	<b>Operation</b>	<b>35</b>
4.1	Switch off the analyser	35
4.2	Power up	36
<b>5</b>	<b>User interface</b>	<b>38</b>
5.1	User interface overview	38
5.2	Introduction	38
5.3	General techniques	39
5.4	Touchscreen and Navigation overview	40
5.5	Home screen	43
5.6	Main Menu screen icons	44
5.7	System and measurement status icons and notices	46
<b>6</b>	<b>Analyzer Menu Branch Structure</b>	<b>48</b>
6.1	Menu branch structure	48
<b>7</b>	<b>Measurement branch screens</b>	<b>62</b>
7.1	Configuring manual calibration and Auto-Cal sequences	66
7.2	Configuring the measurement alarms	67
7.3	Configuring the User Ranges for mA Output and Screen Display	75

7.4	Configure the measurement mA Output.....	82
7.5	Select the displayed number of decimal places for the mA input.....	84
7.6	Configure the measurement record option.....	85
7.7	Configuring the Measurement data filter and gas reporting units .....	87
7.8	Transducer Diagnostics .....	88
<b>8</b>	<b>Diagnostics branch screen .....</b>	<b>89</b>
8.1	Diagnostic branch icons.....	89
8.2	Saving the system log files .....	91
8.3	Testing the Relays .....	91
8.4	Displaying the System or Calibration Log.....	93
<b>9</b>	<b>Maintenance branch screen.....</b>	<b>94</b>
9.1	Disk Management.....	95
<b>10</b>	<b>Settings branch screen .....</b>	<b>96</b>
10.1	Serial outputs overview.....	98
10.2	Assigning relay activity functions .....	103
10.3	Assigning Password Protection.....	106
10.4	Manual relay over-ride setting.....	109
10.5	Setting the analyzer date .....	111
10.6	Setting the analyzer time .....	112
10.7	Setting the Inputs.....	112
10.8	Setting the Network Address (Modbus TCP/IP) .....	119
10.9	Screen Settings .....	119
10.10	Analog Output Adjustment .....	125
10.11	Analog Output Assignment .....	126
10.12	Global Block Averaging.....	129
<b>11</b>	<b>Manual Calibration and Auto-Cal Sequences .....</b>	<b>131</b>
11.1	Definition of Terms Used .....	131
11.2	Introduction to Calibration .....	131
11.3	Calibration Gas Standard Requirements.....	132
11.4	Recommended calibration periods.....	133
11.5	Manual calibration.....	133
11.6	Auto-Cal validation and calibration sequences.....	138
11.7	Auto-validation sequence steps .....	141
11.8	Auto-Calibration Sequence Steps .....	148
11.9	Auto-Cal Thresholds settings per sequence.....	156
11.10	Auto-Cal sequence timing setup .....	158
11.11	Auto-calibration valve installation.....	160
11.12	External inputs for Auto-Cal .....	161
11.13	Relays used for auto-calibration / validation.....	161
11.14	Calibration log file .....	162

<b>12</b>	<b>Technical specification .....</b>	<b>163</b>
12.1	Mechanical specification .....	163
12.2	Electrical specification.....	163
12.3	Maximum voltage ratings .....	164
12.4	Environmental limits.....	165
<b>13</b>	<b>Routine maintenance.....</b>	<b>166</b>
13.1	Cleaning the analyzer .....	166
13.2	Routine checks .....	166
13.3	Preventative maintenance .....	168
<b>14</b>	<b>Troubleshooting .....</b>	<b>170</b>
14.1	Error codes .....	170
14.2	Jam conditions.....	170
<b>15</b>	<b>Storage and disposal.....</b>	<b>171</b>
15.1	Storage.....	171
15.2	Disposal.....	171
<b>16</b>	<b>Spares .....</b>	<b>172</b>
<b>17</b>	<b>Warranty .....</b>	<b>175</b>
17.1	Maintenance policy .....	176
<b>Appendix A Compliance and standards .....</b>		<b>177</b>
A.1	Applicable EU Directives.....	177
A.2	Applicable standards .....	177
<b>Appendix B Optional RS485 / RS232.....</b>		<b>178</b>
B.1	Serial Communication introduction.....	178
B.2	Connections.....	178
B.3	Serial set up parameters.....	179
B.4	Streaming RS232 output.....	181
<b>Appendix C Implementation guide for Modbus communications.....</b>		<b>183</b>
C.1	Introduction.....	183
C.2	References .....	183
C.3	Modbus setup .....	183
C.4	Supported function codes .....	183
C.5	Exception codes .....	184
C.6	Addressing.....	184
C.7	Floating point numbers .....	184
C.8	System data.....	185
C.9	System Settings.....	186
C.10	System Control .....	187
C.11	Measurements.....	187
C.12	Transducer calibration data.....	187

C.13	Transducer live info .....	188
C.14	Transducer settings .....	190
C.15	Relay control.....	191
C.16	Resource live info .....	191
C.17	Resource settings .....	191
C.18	Transducer control.....	192
<b>Appendix D PROFIBUS .....</b>		<b>193</b>
D.1	Safety .....	193
D.2	Description.....	193
D.3	Electrical installation .....	193
D.4	PROFIBUS settings .....	194
D.5	PROFIBUS DPV0 features .....	195
D.6	PROFIBUS Troubleshooting.....	208
<b>Appendix E Return Authorization Request.....</b>		<b>209</b>
E.1	Return Authorization Product Number Request .....	209
E.2	Return Product Authorization Number (RAN) Request Form .....	210
E.2	Decontamination Certificate.....	212
<b>Appendix F Transducer FSD values.....</b>		<b>213</b>
<b>Appendix G Single Beam Single Wavelength (SBSW) transducer information .....</b>		<b>214</b>
G.1	Transducer low and high calibration.....	214
<b>Appendix H Paramagnetic transducer information.....</b>		<b>216</b>
H.1	Overview of measurement errors for paramagnetic O <sub>2</sub> transducer.....	217
H.2	Cross interference offsets (for paramagnetic transducer).....	218
<b>Appendix I 1210 Gas Filter Correlation (GFX) transducer information .....</b>		<b>224</b>
I.1	GFX transducer low and high calibration .....	224
<b>Appendix J Sample wetted materials information .....</b>		<b>228</b>
<b>Index</b>		<b>230</b>

# 1 Introduction

---

## 1.1 About this manual

### 1.1.1 Scope of the manual

This manual covers the installation, operation and routine maintenance of the **MultiExact 4200 analyzer**. It is intended for those already familiar with the installation, use and maintenance of analytical or process instrumentation.

General information on the analyzer is given in the main body of this manual. Transducer-specific information is contained in the relevant appendix at the rear of the manual.

A separate Quick Start Guide is also supplied with the analyzer, reference part number. This details software configuration and operation of the analyzer needed to get the MultiExact 4200 analyzer up and running. Extra copies may be ordered from Servomex.

Use this manual for:

- Installation: To take commissioning to the point where the analyzer is powered and operational. The installer is advised to read this manual completely before commencing installation.
- Configuration: How to set up the clock, passwords, alarm levels, analogue outputs, relays and other parameters.
- Calibration: How to use the manual and automatic calibration/checking facilities.
- Review: How to display analogue output / input settings, relay allocation, alarms, faults and analyzer identity without changing the analyzer settings.

### 1.1.2 Safety information

Read this guide and make sure you fully understand its contents before you attempt to install, use or maintain the analyzer.

The user is solely responsible for implementing appropriate environmental monitoring, ventilation and gas safety controls for flammable and/or toxic gas installations to meet all relevant safety standards including but not limited to those imposed by legal, governmental, statutory, industrial, regulatory and/or corporate requirements.



**The MultiExact 4200 analyzer is only suitable for installation in safe areas. If it is used with flammable samples, it must be part of a system meeting applicable governmental, industrial, regulatory and/or corporate safety standards. This analyzer is for use indoors in a clean and dry environment of pollution degree 2, as defined in EN 60664-1.**

See section 2 for further details on safety.

The following icons are used throughout this guide to identify any potential hazards that could cause serious injury to people. Always follow the safety instructions and be aware of the hazard.



This symbol warns of specific hazards which, if not taken into account, may result in personal injury or death.



This symbol warns of specific hazards due to flammable gas samples which, if not taken into account, may result in personal injury or death.



This symbol warns of specific hazards due to Toxic Gas Samples which, if not taken into account, may result in personal injury or death.



This symbol warns of specific hazards due to high voltages which, if not taken into account, may result in personal injury or death.



This symbol warns of specific hazards due to high temperatures which, if not taken into account, may result in personal injury or death.



This symbol warns of specific hazards due to hazardous substances which, if not taken into account, may result in personal injury or death.



This symbol warns of specific hazards due to caustic or corrosive substances which, if not taken into account, may result in personal injury or death.



This symbol highlights where you must take special care to ensure the analyzer or other equipment or property is not damaged.

### 1.1.3 Other information provided by the manual

*Note:* Notes give extra information about the equipment.

*Hint:* Hints give helpful tips and highlight information which is useful for you to be aware of, for example, specific operating conditions.

## 1.2 Applicable EU Directives, Standards, Certification

- Low Voltage Directive (2014/35/EU)
- Electromagnetic Compatibility (EMC) Directive (2014/30/EU)
- EN 61010-1:2010



- EN 61326-1:2013 / IEC 61326-1:2012, Class A. Intended for professional measurement and control purposes in industrial process and industrial manufacturing environments or is a component of such equipment. It is not intended for use in domestic applications, the MultiExact 4200 does not meet CISPR 11 class B emission limits for residential locations, which are directly connected to low voltage power supply networks.

## 1.3 Product overview

The MultiExact 4200 Analyzers are designed to meet the needs of the control and product quality applications of industrial gas producers and users, who require fast, accurate and reliable gas analysis.

The analyzer can be fitted with up to four sensors: paramagnetic, gas filter correlation (GFX), and single beam single wavelength infrared (IR) transducers.

Gas sample measurements are shown on the analyzer display, and can also be output to a serial device connected to the analyzer, or as milliamp (mA) / voltage outputs, or over a selection of digital communications protocols.

The analyzer conforms to the requirements of the NAMUR (Normenarbeitsgemeinschaft für Mess Und Regeltechnik in der Chemischen Industrie) standards NE43 (4 – 20 mA output) and NA64 (status outputs).

The analyzer is simple to operate, with an intuitive user interface. The benchtop analyzer is 141.2 mm (5.6") high (274.2 mm (10.8") high with expansion chassis), 432 mm (17") wide and 544.2 mm (21.4") deep; the rack mount analyzer is 132.5 mm (5.2") high (265.5 mm (10.5") high with expansion chassis), 482 mm (19") wide and 544.2 mm (21.4") deep.

The main analyzer unit weighs approximately 14 kg (30.9 lb.), with an expansion chassis weighing approximately 13.7 kg (30.2 lb.) if multiple GFX sensors are chosen. The analyzer is suitable for 19-inch rack, panel or bench mounting.

The analyzer requires little routine maintenance, other than calibration which is essential for the accuracy of sample gas measurements (Section 6) and replacement of filter elements (if fitted external to the analyzer).

The MultiExact 4200 product complies with BS EN61326-1:2013, Class A. The MultiExact 4200 is intended for professional measurement and control purposes in industrial process and industrial manufacturing environments or is a component of such equipment. It is not intended for use in domestic applications because the MultiExact 4200 does not meet CISPR 11 class B emission limits for residential locations, which are directly connected to low voltage power supply networks.

The analyzer is not intended for use with corrosive samples and requires a gas conditioning system if the gas stream is hot and wet. This provides protection of the analyzer and requires little routine maintenance. Replacement of an external filter element, if one is fitted as well as regular plumbing checks, are the only maintenance items.

Calibration is essential for the accuracy of sample gas measurements and should be done on a regular basis per recommendations in Section 1.5 for the transducers ordered, or as required by the local regulatory body.

## 1.4 General description

The MultiExact 4200 analyzer is simple to operate, with an intuitive user interface that will display data from external sources. The chassis accepts up to four gas modules. It provides power, gas connections and other support functions to the gas sensor modules and processes their outputs to provide the sample gas concentrations. Gas measurements are shown on the analyzer display and at the same time are sent out of the analyzer to other devices using serial, milliamp (mA), voltage or digital communications protocols.

The analyzer supports up to four external analog input signals that can then be displayed on the screen as measurement signals, and output through the analog and/or the serial outputs or accessed using Modbus or PROFIBUS protocols. These external input signals can be recorded, used to activate relays, or trigger auto-calibration / validation routines or low / high alarms.

The MultiExact 4200 is safe for use with flammable and/or toxic samples when the requirements of section 2 are met. See section 2 for safety warnings and end user responsibilities with respect to flammable and/or toxic samples.

### ***Included with each analyzer ordered:***

- 4 Relays contacts provided as standard (up to 8 relays per option board, 32 relays max with 4 option boards)

### ***Included with each transducer ordered:***

- Each transducer is configured with one option board
- Two alarms are activated (up to 8 alarms per option board, 32 max with 4 option boards)
- OUTPUT: 1 Isolated 4-20mA (1 per option board, 4 max with 4 option boards)

### ***If Auto-Cal is purchased, then the following is included:***

- 8 Relays per transducer
- 6<sup>th</sup>, 7<sup>th</sup>, 8<sup>th</sup> relays pre-assigned as Zero, Span, Sample gas per transducer
- Software to allow auto-calibration / validation based upon a timer (gas switching is via user installed externally located valves).

### ***Options available per transducer:***

Additional option boards can be fitted to obtain the following features:

- A further 2 or 6 alarms (making a total of 4 or 8 alarms) per transducer
- OUTPUT: 0 – 10 VDC per transducer (1 per option board, 4 max with 4 option boards)

- INPUT: 2 Digital per transducer (2 per option board, 8 max with 4 option boards)
- INPUT: 1 Isolated 4-20mA per transducer (1 per option board, 4 max with 4 option boards) – can be flexibly assigned to any measurement

**Other optional features are also available:**

- Serial Communications using RS232, RS485, RS232 & RS 485 Combo, Modbus RDU, Profibus, Ethernet (Modbus TCP/IP)

*Note: It is recommended to fit an external 0.01 microns sample filter to protect the gas transducer modules from particulate contamination*

Use this manual for:

Installation	To take commissioning to the point where the analyzer is powered and operational. The installer is advised to read this manual completely before commencing installation.
Configuration	To setup the clock, passwords, alarm levels, analog inputs or outputs, relays and other parameters
Calibration	How to use the manual and automatic calibration/checking facilities
Review	How to display analog output settings, relay assignment, alarms, faults, and analyzer identity without changing the analyzer settings.

## 1.5 Recommended calibration intervals

For optimum performance, it is necessary to routinely check the calibration of all the internal gas transducers within the analyzer. The recommended periods for each transducer type are shown in Section 11.4.

This manual provides details of the following:

- the requirements for and configuration of calibration ancillaries (e.g. gases)
- the setup of the auto-calibration / validation routines
- the connection of external solenoid valves (when auto-calibration is used)
- the use of the RS232 output and remote initiation of calibration
- the use of Modbus or PROFIBUS to initiate calibration



**If the intended use of this equipment is to monitor process systems critical for Health and Safety purposes, it is the sole responsibility of the installer and operator to see that this instrument is commissioned, maintained and calibrated in a manner consistent with the customer's**

**specific application. Continued safe and reliable operation of this equipment is conditional on all installation, operation and maintenance procedures being carried out in accordance with the appropriate manuals, by personnel having appropriate qualifications, experience and training. Failure to observe the requirements of the manual may result in the user being held responsible for the consequences. In no event shall Servomex be liable for any incidental, consequential or special damages of any kind or nature whatsoever, including but not limited to lost profits arising from or in any way connected with this instruments use.**

## **1.6 Automatic calibration options**

Two functions are provided when the optional Auto-Cal feature is ordered. These functions are performed on the transducer.

- Auto-calibration: Changes the actual calibration curve
- Auto-validation: Reads the value to determine if it is within the specified tolerance, making no changes to the calibration curve.

Each transducer can have up to three sequences of auto-calibration or auto-validation attached to it.

To use the auto-calibration/ validation routine, customer supplied solenoid valves will be controlled by discrete wiring to the relays for each of the transducers for running sample, zero and span gases (see Section 3.3.3).

The automatic calibration procedure may be started by any of the following:

- A trigger from the internal instrument clock
- An external contact closure
- A Modbus or PROFIBUS command

*Note: When the optional auto-calibration option is configured, the manual calibration process will use the auto-calibration valves to select the calibration gases as required.*

## 1.7 Product identification



**Figure 1-1: Standard MultiExact 4200 Gas Analyzer configured for rack-mount**

**Figure 1-2: Rear of the MultiExact 4200 Gas Analyzer configured for two sample streams**

Table 1-1 provides a general overview of the connectors on the back of the analyzer. Connections for optional features will be inactive unless the optional feature has been purchased.

**Table 1-1: Rear panel connections**

ID	Description	ID	Description
J9 – J16	Relay I/O connections	J26 – J33	Relay I/O connections
J17	DIN (1A-C / 2A-C)	J34	DIN (5A-C / 6A-C)
J18	DIN (3A-C / 4A-C)	J35	DIN (7A-C / 8A-C)
J19	Option board 1&2 4-20 mA inputs	J36	Option board 3&4 4-20mA inputs
J20	4 – 20 mA output / voltage output (I1± / V1±)	J37	4 – 20 mA output / analog voltage output (I3± / V3±)
J21	4 – 20 mA output / voltage output (I2± / V2±)	J38	4 – 20 mA output voltage output (I4± / V4±)
PROFIBUS	Profibus connector	RS-232	RS232
ETHERNET	Ethernet connector	RS-485	RS485 (Modbus)
AQUAXACT 1688	AquaXact 1688 connector <b>(not available at this time)</b>		Earth (ground) connection

## 1.8 Sample requirements

For best performance the flow supplied to the analyzer should be kept at a constant value and the analyzer must be freely vented to atmosphere, for both process sampling and for calibration gas input.

Flow Rate:	Nominal 1500 mL/min (Min 500 mL/min, Max 2000 mL/min)
Temperature:	5 to 40°C / 41 to 104°F
Dew point:	5°C / 9°F below minimum ambient
Condition:	Oil free, non - condensing, filtered to 1µm
Vent:	Connect the outlet of the analyzer to a separate atmospheric vent, free from any back-pressure
Warm up Time:	Typically, 24 hours from cold start to 20°C / 68°F <b>High sensitivity measurements may take longer to warm up.</b>



**Pay particular consideration to the toxicity and asphyxiant nature of the sample gas when selecting a vent location.**



**Corrosive gases are not intended to be used in these analyzers.**



**Make sure that if pressurized gases are used to keep the pressure below 0.75 psig (5.2 kPa g).**



**Do not exceed the rated flow or pressure as transducer damage may result. Best practice is to place a pressure relief valve on the inlet line, venting any gas to a safe exhaust area.**

## 2 Safety

---

### 2.1 Appropriate environmental monitoring, ventilation and gas safety controls

The user is solely responsible for implementing appropriate environmental monitoring, ventilation and gas safety controls for flammable and/or toxic gas installations to meet all relevant safety standards including but not limited to those imposed by legal, governmental, statutory, industrial, regulatory and/or corporate requirements.



Before you attempt to install, commission or use the MultiExact 4200 analyzer, read this manual carefully.



Do not attempt to install, commission, maintain or use the MultiExact 4200 analyzer unless you are trained and know what you are doing. The analyzer must be maintained by a suitably skilled and competent person.



Do not connect the MultiExact 4200 analyzer to a power source until all relays, input/ output signals and plumbing connections are made.



This analyzer must be operated in a manner consistent with its intended use and as specified in this manual.



**THIS ANALYZER IS NOT FOR USE IN HAZARDOUS AREAS.**



The MultiExact 4200 analyzer is only suitable for installation in safe areas. If it is used with flammable samples, it must be part of a system meeting applicable governmental, industrial, regulatory and/or corporate safety standards. This analyzer is for use indoors in a clean and dry environment of pollution degree 2, as defined in EN 60664-1.



Plumbing must be checked on a regular basis for leaks. Perform this check on the same schedule as calibrations (every 6 months).



When calibrating or servicing the analyzer, end user must flush system with an inert gas. Ensure analyzer has been fully purged prior to calibrating or servicing.



The maximum pressure to the analyzer must be limited 0.75 psig (5.2 kPa g) by means of a suitable release system such as a pressure release valve or needle valve installed in line with the analyzer inlet streams.



Do not modify the unit, either mechanically or electrically, or the certification and warranty of the instrument will be invalidated, and it may not operate safely.





The MultiExact 4200 analyzer includes few user-serviceable parts which, are called out in the spare list in the appendix.



Do not use the MultiExact 4200 analyzer as Personal Protective Equipment (PPE).



Make sure that all floors or platforms where you install the MultiExact 4200 analyzer are large enough for you to move freely and to change position.



The MultiExact 4200 analyzer may be attached to equipment that is hot. Always wear the appropriate PPE to minimize the risk of burns.

## 2.2 Chemical & Flammability Warnings



Sample and calibration gases may be toxic, or asphyxiant, and/or flammable:



- Make sure that the external connections are leak free at full operating pressure before you use sample or calibration gases.
- Make sure that the sample/bypass outlet pipes are vented to an area where the gases will not be a hazard to people.
- Make sure that the analyzer is used in a sufficiently well-ventilated environment, to prevent the build-up of toxic and/or flammable gases.
- Make sure that the pipes that you connect to the analyzer are routed so that they do not present a hazard to people.
- Never inspect the inlet filter(s), or service or repair the analyzer while such gases are still connected to it.
- If the analyzer is to be serviced or repaired, it is important that all pipework is flushed with an inert gas and the analyzer is allowed to freely vent to local atmosphere.



Where there is a risk of release of potentially harmful gases into the operating environment, always use suitable monitoring equipment.



The user is responsible for implementing appropriate environmental monitoring, ventilation and gas safety controls for flammable and/or toxic gas installations to meet governmental, industrial, regulatory and/or corporate safety standards. See section 2.1 for additional information.



The MultiExact 4200 is not suitable for use with corrosive samples.

## 2.3 System Considerations



The MultiExact 4200 analyzer is only suitable for installation in safe areas. If it is used with flammable samples, it must be part of a system meeting applicable governmental, industrial, regulatory and/or corporate safety standards. This analyzer is for use indoors in a clean and dry environment of pollution degree 2, as defined in EN 60664-1..

Safety shall be the foremost design parameter during all stages of the system design around the analyzer.

- The system design shall be in accordance with all applicable codes and standards, and all electrical equipment and instrumentation shall meet the electrical area classification where installed (for example National Fire Protection Associate NFPA 496, International Electrotechnical Commission IEC TR61831)

- For highly toxic process samples, the following shall be considered:

- Distance (minimize) of the analyzer to the process sample source point
- Quantity (minimize) of sample needed for a reliable, safe, and speedy analysis
- Distance of the analyzer to the sample disposal or return point for proper disposal of spent samples
- Availability of safety support equipment, such as breathing air stations, safety showers, etc.
- Emergency escape routes from the analyzer location
- Location of toxic gas monitors and alarm devices
- Physical protection of sample tubing and probe

- For flammable samples, the following shall be considered:

- The lower explosive limit of sample stream constituents
- The lower explosive limit of chemical reagent components
- Surface temperature of sample system hardware components (T-Rating)
- Need and location of combustible area monitoring detectors and the calibration of the monitors for the sample stream
- Sources of static electricity such as air conditioner blowers, etc.
- Safety issues with any of the other process analysis requirements
- Physical protection of sample tubing and probe

## 2.4 Electrical warnings



Always observe the appropriate electrical safety codes and regulations.



**Make sure that the electrical installation of the analyzer conforms with all applicable local and national electrical safety requirements.**



**Potentially hazardous AC voltages are present within this instrument. Leave all internal servicing to qualified personnel. Disconnect the AC power source before installing or removing any external connections.**



**Make sure the analyzer is provided with a sound earth connection via the electrical supply plug.**



**Make sure the electrical supply coupler or plug is easily accessible for disconnection from the electrical supply.**



**All signal and electrical supply cables must be rated for temperatures of 70°C or higher.**



**The I/O terminals and connections are separated from the analyzer mains circuits by reinforced insulation. The terminals must only be connected to circuits that are themselves separated from mains voltages by at least reinforced insulation.**



**Make sure that the cables that you connect to the analyzer are routed so they do not present a trip hazard.**

## 2.5 Electromagnetic Compatibility (EMC) considerations

The MultiExact 4200 analyzer meets the essential requirements of the European EMC Directive (2014/30/EU). The transducer and the 4-20 mA loop are electrically connected but are isolated from the analyzer housing and sample cell fitting threads.

The analyzer generates and uses small amounts of radio frequency energy. There is no guarantee that interference from radio or television signals will not occur in a particular installation. If interference is experienced, switch off the analyzer to see if the interference disappears. If it does, try one or more of the following methods to correct the problem:

- Re-orient the receiving antenna.
- Move the instrument with respect to the receiver.
- Place the analyzer and receiver on different AC circuits.

Always consider the following electromagnetic interference issues when installing the MultiExact 4200 analyzer:



**To provide an acceptable noise environment for the MultiExact 4200 analyzer or other digital equipment in the proximity of switching**

inductive loads, Servomex recommends that you place varistors across the inductors to lessen high voltage spikes that occur during transitions.



Circuitry activated by relay contacts should allow for the contact bounce. One simple method is to place a capacitor across the relay contacts.



Route AC power wiring as far from the analyzer and its wiring as possible.

## 2.6 Markings

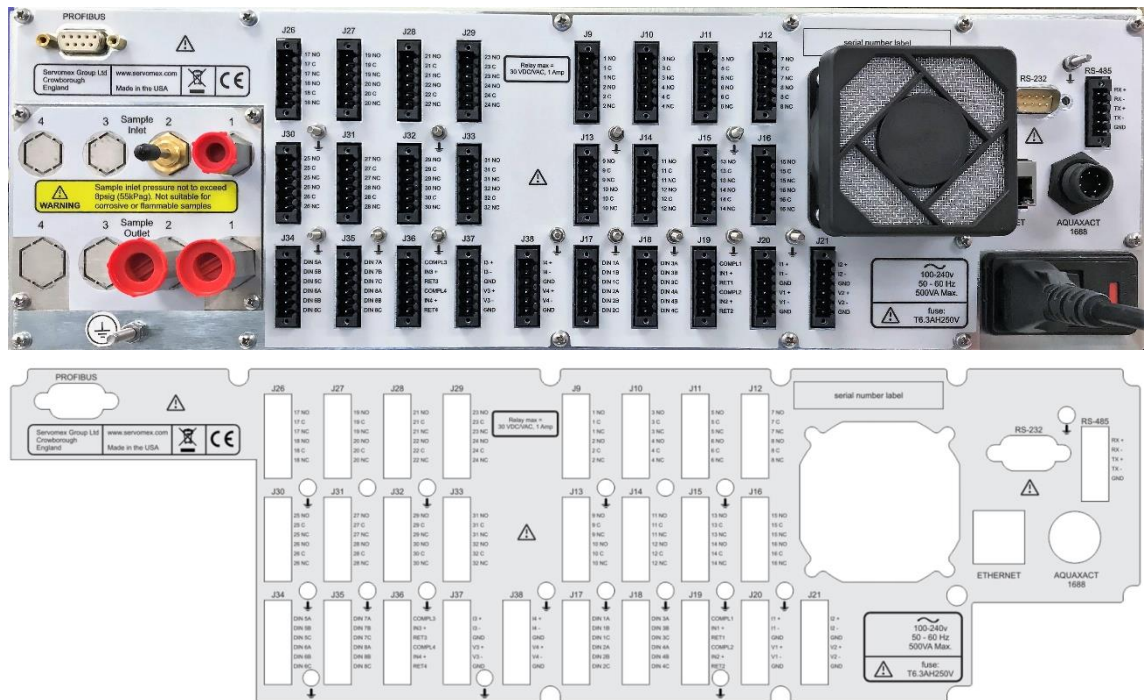

Figure 2-1: Rear of the MultiExact 4200 analyzer

The MultiExact 4200 analyzer includes the following external markings on the rear panel and correspond to:



**Do not connect any cables carrying mains voltage or cables that have inadequate insulation between line and mains to any of the I/O connectors.**



**Earth / ground connections. These are screw terminals used to connect the ground shields of cables plugged into the nearby connectors. Do not connect any voltages to these connections.**



**This label identifies that:**

- **The analyzer is considered to be within the scope of the Waste Electrical and Electronic Equipment (WEEE).**
- **The analyzer is not intended for disposal in a municipal waste stream (such as landfill sites, domestic recycling centers and so on), but must be submitted for material recovery and recycling in accordance with the local regulations which implement the WEEE Directive.**

Follow the appropriate safety instructions and be aware of any warnings about potential hazards.

### 3 Installation and set-up

---



Do not attempt to install, commission, maintain or use the MultiExact 4200 analyzer unless you have been trained or are an experienced instrument technician.



The MultiExact 4200 analyzer is only suitable for installation in safe areas.



Follow the instructions in this section to safely install the MultiExact 4200 analyzer.



Make sure that all floors or platforms where you install the MultiExact 4200 analyzer are large enough for you to move freely and to change position.



Do not install the unit in places subject to extreme mechanical vibration, temperature changes or shock. If you do, measurements may not be accurate, or the analyzer may be damaged.



If used with flammable samples, analyzer must be used in a system meeting the requirements of section 2.1.

#### 3.1 Unpacking



Read this manual carefully **BEFORE** you remove the MultiExact 4200 Gas Analyzer from its shipping container, or you attempt to install, commission or use the equipment.

1. Remove the analyzer and any other equipment from its packaging.
2. Remove the protective plastic covers from the sample gas inlets and outlets on the rear of the analyzer (Figure 3-1).

**Figure 3-1: Gas inlets and outlets on rear of the analyzer**

**Hint:** Remove the RED and BLACK protective covers before connecting to the sample gas pipework. If you do not intend to use the analyzer immediately,

Gas inlets →

Gas outlets →

*wait to remove the plastic covers until just before connecting to the sample gas pipework.*

3. Inspect the analyzer and the other items supplied and check that they are not damaged. If any item is damaged, contact Servomex or your local Servomex agent immediately.
4. Check the packing list to ensure you have received all the items ordered. If any item is missing, contact Servomex or your local Servomex agent immediately.
5. If you do not intend to use the analyzer immediately:
  - a. Refit any protective plastic covers that you may have removed.
  - b. Place the analyzer and any other equipment supplied back in its protective packaging.
  - c. Store the analyzer as described in section 15.1.
6. Read Section 2 – Safety before proceeding.

***Hint:** Keep all shipping packaging and documentation for future use when moving, storing or returning the analyzer for service or repair.*

## 3.2 Mechanical Installation

### 3.2.1 Bench mounting

4 rubber feet beneath the analyzer allow use on a firm level bench or other suitable solid work surface. If used with flammable samples, the analyzer must be located within an enclosure per section 2.1. **NOTE an external safety system must be used with this analyzer if flammable samples are present. System safety requirements in section 2 must be met.**

### 3.2.2 Rack mounting

Before installing the analyzer, determine where you will install it in the rack enclosure. The standard analyzer is 3U in height and has two mounting bolts on each side.

There is an option for a sliding rack mount (Figure 3-2). **NOTE an external safety system must be used with this analyzer if flammable samples are present. System safety requirements in section 2 must be met.**



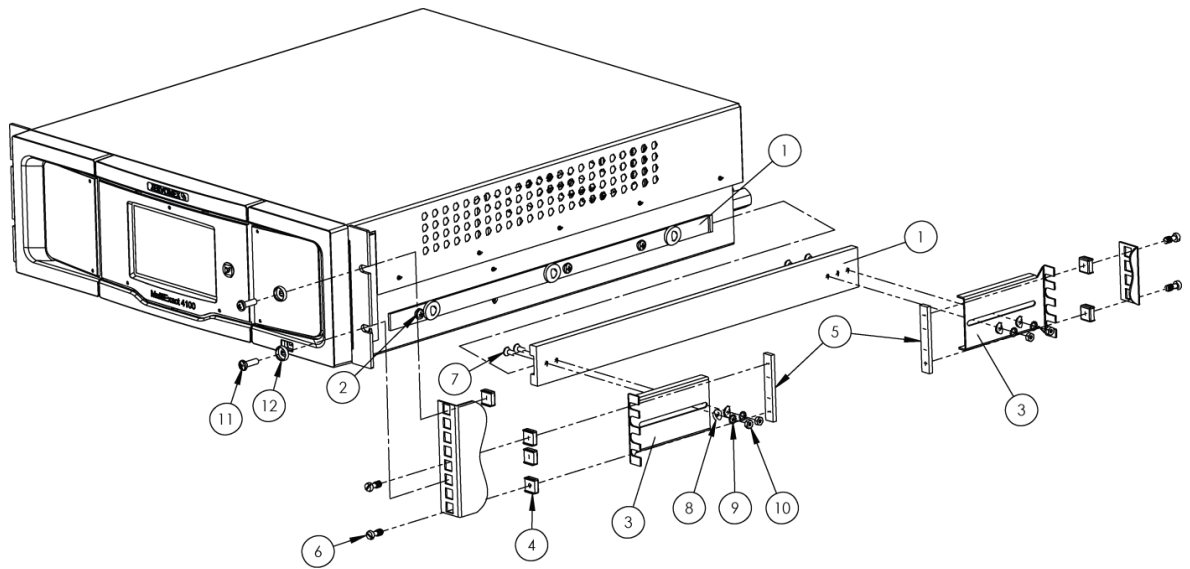

- |   |                        |    |                      |
|---|------------------------|----|----------------------|
| 1 | Telescopic slide       | 7  | M4 screw             |
| 2 | M5 screw               | 8  | M4 washer            |
| 3 | Slide support bracket  | 9  | M4 locking washer    |
| 4 | Cage nut               | 10 | M4 nut               |
| 5 | Slide support clamp    | 11 | M5 cross-head screw  |
| 6 | M5 waisted brass screw | 12 | Cup washer (plastic) |

**Figure 3-2: Sliding rack installation (M indicates metric value in mm)**

## 3.3 Electrical installation

### 3.3.1 Electrical safety



Make sure that the electrical installation of the analyzer conforms with all applicable local and national electrical safety requirements.



Make sure the electrical supply plug is easily accessible for disconnection from the electrical supply.



Make sure the analyzer is provided with a sound earth connection via the electrical supply plug.



All signal and electrical supply cables must be rated for temperatures of 70°C or higher.



Make sure that the cables that you connect to the analyzer are routed so they do not present a trip hazard.



Follow the instructions given below when you install the analyzer. If you do not, the analyzer warranty may be invalidated, the analyzer may not operate correctly, or it may be damaged.



Make sure your electrical supply can provide the necessary maximum power consumption.

### 3.3.2 Analog output signal connections



The analog output terminals are separated from the analyzer mains circuits by reinforced insulation. The terminals must only be connected to circuits that are themselves separated from mains voltages by at least reinforced insulation.



To comply with EMC requirements, shielded cables must be used to connect the analog outputs.

Refer to Table 3-1 to identify which screw terminal (J20, J21, J37, and J38) is connected to which gas transducer position.

**Table 3-1: Analog output interface connectors**

Screw Terminal	Gas Transducer	Screw Terminal	Gas Transducer
J20	Position / Measurement #1	J37	Position / Measurement #3
J21	Position / Measurement #2	J38	Position / Measurement #4

Connect the cable wires to the pins on J20 (Gas #1), J21 (Gas #2), J37(Gas #3), J38 (Gas #4) for the available outputs on the transducers, as shown in Table 3-2. The (X) in the table indicates the gas measurement location in position 1, 2, 3, or 4 that matches the connector listed in Table 3-2 with the label on the back of the analyzer:

**Table 3-2: Analog output interface connectors**

Pin	Use	Output Configuration	Pin	Use	Output Configuration
1	I(X)+	mA current	4	V(X) +	voltage
2	I(X) -	mA current	5	V(X) -	voltage
3	GND	Chassis ground	6	GND	Chassis ground

Connect the cable shielding to the ground point on the rear of the analyzer. The ground points are marked with the  symbol, or if more convenient the screw terminals at pins 3 and 6 may be used.

### 3.3.3 Analog input signal connections



**The analog input terminals are separated from the analyzer mains circuits by reinforced insulation. The terminals must only be connected to circuits that are themselves separated from mains voltages by at least reinforced insulation.**



**To comply with EMC requirements, shielded cables must be used to connect the analog inputs.**



**The analyzer must supply power for any mA input devices. Do not allow devices on the inputs to supply power or the input readings may not be valid.**



**Analog input number “X” shares the same isolated reference as the analog output with the same number. This reference is isolated from the rest of the chassis as well as from the other analog inputs and outputs. Do not allow equipment wired to an input number X to be grounded to the same frame as equipment reading from output number X, or both input and output X readings may not be valid.**

Refer to Table 3-1 to identify which screw terminal (J20, J21, J37, and J38) is connected to which gas transducer position.

**Table 3-3: Analog output interface connectors**

Screw Terminal	mA Input	Screw Terminal	mA Input
J19	Input #1, #2	J36	Input #3, #4

Connect the input cable wires to the pins on J19 (inputs #1 and #2), J36 (inputs #3 and #4), as shown in Table 3-4. The (X) in the table indicates the input location in position 1, 2, 3, or 4 that matches with the label on the back of the analyzer:

**Table 3-4: Analog input interface connectors**

Pin	Use	Input Configuration	Pin	Use	Input Configuration
1	COMPL(X)	Compliance out	4	COMPL(X)	Compliance out
2	IN(X) +	mA input return	5	IN(X) +	mA input return
3	RET(X)		6	RET(X)	

Connect the cable shielding to the ground point on the rear of the analyzer. The ground points are marked with the  symbol. Connect an external mA loop device “+” to the COMPL(X) pin and connect the external device “-” to the IN(X)+ pin. The RET(X) pins cannot currently be used.

### 3.3.4 Relay connections

**Figure 3-3: Rear of MultiExact 4200**



**The relay connections are separated from the analyzer mains circuits by reinforced insulation. The terminals must only be connected to circuits that are themselves separated from mains voltages by at least reinforced insulation.**

*Note: The relays do not have default settings unless Auto-Cal is selected. Users can create alarms and assign them to any relay (Section 10.2).*

*Note: When Auto-Cal is purchased, each transducer has 8 relays available with 3 relays preassigned - the 6<sup>th</sup> assigned to Zero, the 7<sup>th</sup> to Span and the 8<sup>th</sup> to the Sample*

gas. The 1<sup>st</sup> to the 5<sup>th</sup> relays can be assigned to any alarm or function even if it is not related to that particular gas transducer (Section 10.2).

The analyzer relays are accessible via the connectors J9-J16 and J26-J33. Connect one end of your cable wire to the screw terminal for the relevant relay connector as shown in Table 3-3. Each connector has two relays assigned to it where the “X” in XNO, XC, XNC represents the relay number, NO is Normally Open, C is Closed and NC is Normally Closed.

**Table 3-3: MultiExact 4200 relay connections**

Relay	Use	Connector	Relay	Use	Connector
1	1NO, 1C, 1NC	J9	17	17NO, 17C, 17NC	J26
2	2NO, 2C, 2NC	J9	18	18NO, 18C, 18NC	J26
3	3NO, 3C, 3NC	J10	19	19NO, 19C, 19NC	J27
4	4NO, 4C, 4NC	J10	20	20NO, 20C, 20NC	J27
5	5NO, 5C, 5NC	J11	21	21NO, 21C, 21NC	J28
6	6NO, 6C, 6NC Auto-Cal Zero	J11	22	22NO, 22C, 22NC Auto-Cal Zero	J28
7	7NO, 7C, 7NC Auto-Cal Span	J12	23	23NO, 23C, 23NC Auto-Cal Span	J29
8	8NO, 8C, 8NC Auto-Cal Sample	J12	24	24NO, 24C, 24NC Auto-Cal Sample	J29
9	9NO, 9C, 9NC	J13	25	25NO, 25C, 25NC	J30
10	10NO, 10C, 10NC	J13	26	26NO, 26C, 26NC	J30
11	11NO, 11C, 11NC	J14	27	27NO, 27C, 27NC	J31

Relay	Use	Connector	Relay	Use	Connector
12	12NO, 12C, 12NC	J14	28	28NO, 28C, 28NC	J31
13	13NO, 13C, 13NC	J15	29	29NO, 29C, 29NC	J32
14	14NO, 14C, 14NC Auto-Cal Zero	J15	30	30NO, 30C, 30NC Auto-Cal Zero	J32
15	15NO, 15C, 15NC Auto-Cal Span	J16	31	31NO, 31C,31 NC Auto-Cal Span	J33
16	16NO, 16C, 16NC Auto-Cal Sample	J16	32	32NO, 32C, 32NC Auto-Cal Sample	J33

Connect the wires in your cable to the screw terminals on the relevant connectors as shown in Table 3-4 showing Relay X (J odd numbers) and Relay Y (J even numbers) positions on the jumpers listed in Table 3-3.

**Table 3-4: Relay Screw Terminal Pin Connection**

Pin	Use	Output Configuration
1	(X) NO	Normally Open Relay X
2	(X) C	Close Relay X
3	(X) NC	Normally Closed Relay X
4	(Y) NO	Normally Open Relay Y
5	(Y) C	Close Relay Y
6	(Y) NC	Normally Closed Relay Y

For setting up the Zero Gas relay when Auto-Cal is purchased, connect the wires in your cable to the screw terminals of the relevant connectors J11, J15, J28, and J32 (based upon the number and position of the transducers in the analyzer) shown in Table 3-5. “Y” represents the jumper number J11 for gas #1, J15 for gas #2, J28 for gas #3 and J32 for gas #4:

**Table 3-5: Zero Gas Relay Screw Terminal Pin Connections for Auto-Cal**

<b>Pin</b>	<b>Use</b>	<b>Output Configuration</b>	
4	(Y) NO	Normally Open Relay Y	Zero Gas Relay
5	(Y) C	Close Relay Y	Zero Gas Relay
6	(Y) NC	Normally Closed Relay Y	Zero Gas Relay

For setting up the Span Gas and Sample Gas relays when Auto-Cal is purchased, connect the wires in your cable to the screw terminals to the relevant connectors of J12, J16, J29, and J33 as shown below to control the Span Gas Relays and / or Sample Gas Relays shown in Table 3-6. "X" represents the connector J12 for gas #1, J16 for gas #2, J29 for gas #3 and J33 for gas #4 and Pins 1 – 3 control the Span Gas Relays while Pins 4 – 6 control the Sample Gas Relays.

**Table 3-6: Span and Sample Gas Relay Screw Terminal Pin Connections for Auto-Cal**

<b>Pin</b>	<b>Use</b>	<b>Output Configuration</b>	
1	(X) NO	Normally Open Relay X	Span Gas Relay
2	(X) C	Close Relay X	Span Gas Relay
3	(X) NC	Normally Closed Relay X	Span Gas Relay
4	(X) NO	Normally Open Relay X	Sample Gas Relay
5	(X) C	Close Relay X	Sample Gas Relay
6	(X) NC	Normally Closed Relay X	Sample Gas Relay

### 3.3.5 Connect the electrical supply



**Make sure that your external electrical supply outlet is isolated and locked-out before you connect the conductors in the electrical supply cable.**



**Only use the power supply cord provided with the unit.**



**Make sure the analyzer is suitable for use with your electrical supply voltage and frequency (Section 12). If the analyzer is not suitable, it may not operate correctly, or it may be damaged if you operate it.**

The analyzer is supplied with an electrical supply cable and plug, configured for your electrical supply. Connect the electrical supply to the analyzer as follows:

1. Turn the Power Switch on the back of the unit to OFF: press the “O” on the On/Off switch shown in Figure 3-4 A.
2. Fit the IEC plug on the end of the electrical supply cable provided to the electrical supply socket on the rear of the analyzer (Figure 3-4 B).

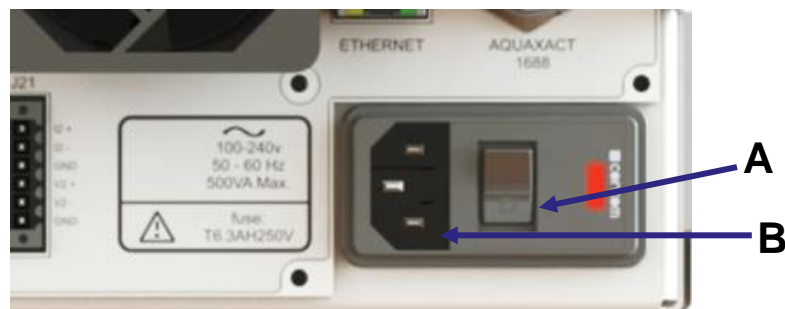

**Figure 3-4: Power switch (A) and electrical supply socket (B) on rear of analyzer**

3. Plug the other end of the electrical supply cable into your electrical supply outlet.
4. Check the earth (ground) continuity between your electrical supply outlet earth (ground) and the functional earth (ground) terminal on the rear of the analyzer.
5. If a local earth bonding is required, the functional earth stud can be used. The earth ground cable must be kept to less than 3 meters to comply with EMC standards.



**This does not replace the earth conductor on the electrical supply socket which must always be connected. Therefore never cut or remove any of the metal pieces from the supplied plug.**

## 3.4 Sample / calibration gas connections





Sample and calibration gases may be flammable, toxic, or asphyxiant:



- Make sure that the external connections are leak free at full operating pressure before you use sample or calibration gases.
- Make sure that the sample/bypass outlet pipes are vented to an area where the gases will not be a hazard to people.
- Make sure that the analyzer is used in a sufficiently well-ventilated environment, to prevent the build-up of toxic gases.
- Make sure that the pipes that you connect to the analyzer are routed so that they do not present a hazard to people.



It is essential that the analyzer is isolated from the sample system until any cleaning solvents are fully purged from the pipelines. Failure to take this precaution may lead to contamination of the transducer, which will be observed as an offset and drift in output.

### 3.4.1 Sample and Calibration Gas Inlets and Outlets

<i>Hint:</i>	This section gives simple instructions about connecting the sample and calibration gas pipelines to the analyzer.
--------------	---

Sample and calibration gases pass into the analyzer via Sample Inlets, (e.g. Figure 3-5 A) and out via Sample Outlets (e.g. Figure 3-5 B).

Figure 3-5: Gas inlets and outlets for two sample streams.

Note: label closeup for MultiExact 4200:

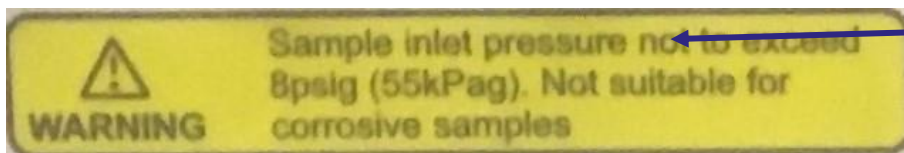

### 3.4.2 Gas connections

Connect your sample/calibration gas inlet and outlet pipelines to the Sample Inlet and Sample Outlet fittings on the rear of the analyzer. See Table 3-7 for the specification of the fittings. Do not over-tighten the fittings.

Table 3-7: MultiExact 4200 sample port fittings

<b>Component</b>	<b>Sample Inlet</b>	<b>Sample Outlet</b>
1520 Series IR	1/8" OD* stainless steel stub	1/8" OD* stainless steel stub
Paramagnetic	1/8" OD* stainless steel stub	1/8" OD* stainless steel stub
Infrared GFX	1/8" OD* stainless steel stub	1/8" OD* stainless steel stub

*\*Note: It is recommended an external filter is fitted (see accessories in Section 16) at the analyzer inlet or, if preferred, at a convenient point in the sample line prior to the inlet.*

### **3.4.3 Gas Flow Rate**

Flow control on the inlet to the analyzer must be provided by the end user using mass flow controllers, manual adjustable valves like needle valves, or electronically controlled metering valves.

Optional (rotameter floating element) flow meter with an integrated metering valve can be configured with the analyzer when ordering through Servomex.

The rotameters are used only for visually checking there is gas flowing through the analyzer and that it does not exceed the flow rate of the instrument. An optional internal flow monitor provides a diagnostic indicator to alert locally or remotely when flow is not going through the analyzer.

For best performance the flow supplied to the analyzer should be kept at a constant value and the analyzer freely vented to atmosphere for both process sampling and for calibration gas input. A nominal flow of 1500 mL/min is recommended, with a minimum of 500 mL/min and a maximum of 2000 mL/min.

## 4 Operation



See Section 1.8 for flow/pressure requirements for the sample, zero and calibration gases. If the flow/pressure are outside the ranges specified in Section 1.8, you must regulate the gases externally, before they enter the analyzer.

### 4.1 Switch off the analyser

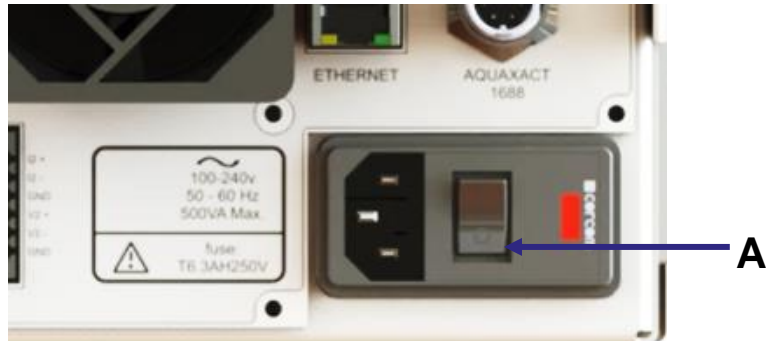

**Figure 4-1: On/off switch on the rear of the analyzer**

To switch off the analyser, press the “O” on the On/Off switch on the rear of the analyzer (Figure 4-1 A).

If you intend to leave the analyzer off for an extended period of time, for example, when carrying out plant maintenance and will not use the analyzer for several days:

- Turn off the analyzer and disconnect the electrical supply cable from the analyzer.
- Purge the transducers with Zero Air or Nitrogen gas to remove any sample gas.
- Close off the sample gas inlet and outlets using a shut off valve or the protective caps supplied with the analyzer.

## 4.2 Power up



Sample and calibration gases may be flammable, toxic, or asphyxiant:

- Make sure that the external connections are leak free at full operating pressure using N<sub>2</sub> or Zero Air before you use sample or calibration gases.
- Make sure that the sample/bypass outlet pipes are vented to an area where the gases will not be a hazard to people.
- Make sure that the pipes that you connect to the analyzer are routed so that they do not present a hazard to people.
- Do not operate the power switch on the rear panel of the analyzer if the unit is known to contain a flammable sample mixture
- The MultiExact 4200 must not be used in the event a display failure is observed



It is essential that the analyzer is isolated from the sample system until any cleaning solvents are fully purged from the pipelines. Failure to take this precaution may lead to contamination of the transducer, which will be observed as an offset and drift in output.

The analyzer can now be powered up.

**Hint:** When the electrical supply to the analyzer is switched on, a series of beeps will be heard, the readings are displayed on screen and the clock in the upper right hand corner of the screen starts running.

To power up the analyser:

1. Make sure that the analyser power cord is connected to the back of the unit.
2. Press the "I" on the On/Off switch on the rear of the analyser (Figure 4-2 A) to power on the analyser.



**Figure 4-2: On/Off switch on the rear of the analyzer, (A) points to the Power Switch “I” for ON position.**

When the analyzer is first switched on, the screen displays a software loading progress bar, followed by the Home screen and the warmup signal **SSS** appears in front of any transducer which is not ready for measurement (Figure 4-3).

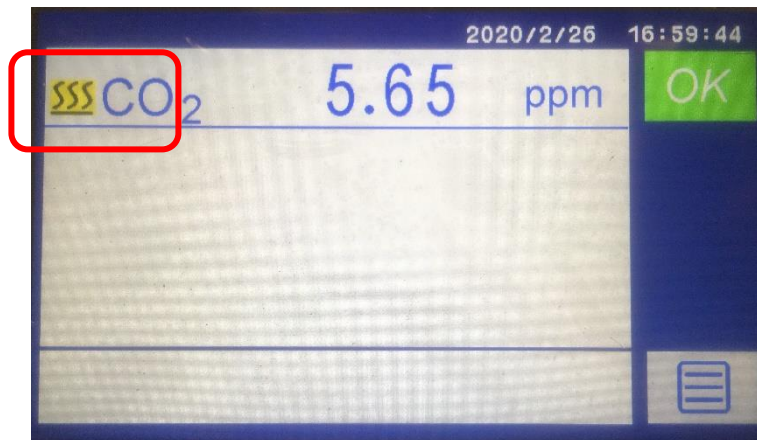

**Figure 4-3: Home screen for a1-transducer analyzer showing the CO<sub>2</sub> warming up**

**Hint:** Figure 4-3 shows the unit in Warm Up mode, indicated by the three wavy lines shown in the upper left corner encircled by the red box.

# 5 User interface

## 5.1 User interface overview

Configuration options referred to in this manual (for example, auto-calibrate / validate) must be specified at the time of purchase. The menus and menu options associated with the options not purchased will appear as grey colored icon buttons (as seen in the red box of Figure 5-1) and will be unavailable for use.

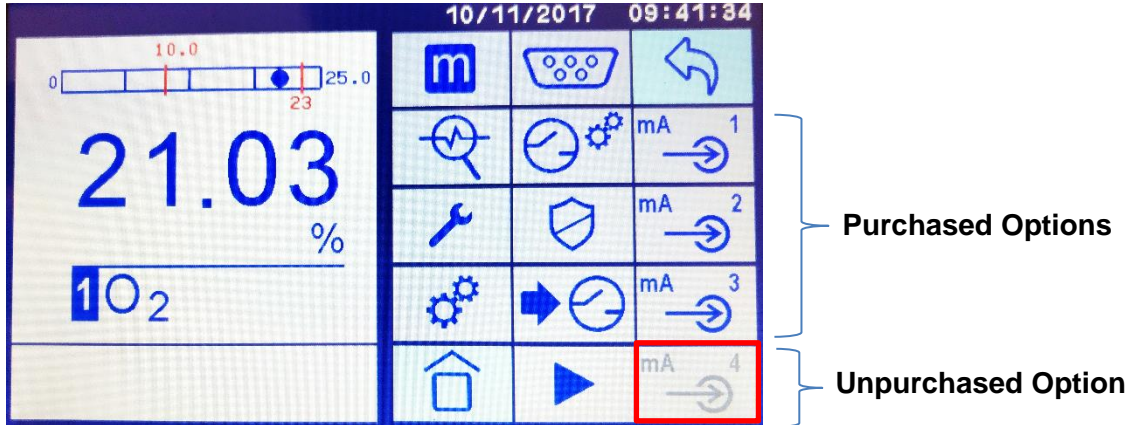

Figure 5-1: Setup Screen Icons showing 3 mA Inputs activated (purchased) and the bottom mA Input is grayed out (not purchased)

## 5.2 Introduction

The user interface is a touchscreen display with icon-driven menus to allow for easy and intuitive operation of the MultiExact 4200 analyzer. Figure 5-2 shows the main display for a four-transducer analyzer with the Main Menu option icon in the lower right-hand corner. MultiExact 4200 analyzers share several standard features with optional features dependent on the configuration of transducers, options purchased and setup preferences.



Figure 5-2: Home screen for a 4-transducer analyzer (A) is the Main Selection Touch Screen and (B) indicates the Main Menu Icon

The user interface comprises the following as shown in Figure 5-2:

- |   |                     |  |
|---|---------------------|--|
| A | Touchscreen display | Screens, horizontal bars and icons are displayed on the touchscreen depending on the information and operation being engaged.            |
| B | Touchscreen icons   | The icons displayed depend on the current screen capabilities / function. When touched the icons will produce a new screen or icon list. |

*Note: If there are no menu interactions for 60 seconds, the display reverts back to this Home screen. This timer can be adjusted in the Settings section.*



To interact with a specific gas transducer, touch on the horizontal bar on the home screen display for that gas transducer when more than one gas stream is displayed or touch the single gas screen. A single screen display will show the gas transducer specific user interactions that are available for the selected item.

*Note: The remainder of the software descriptions will show a single transducer window when appropriate.*

### 5.3 General techniques

The general navigation route through the user interface screens is described by a sequence of icons that you must touch to get to the desired screen. A shortened visual description of the sequence of icons to be touched is used in this manual to help you navigate easily to the various screens.









For example, to reach the Alarms screen (a sub-screen of the Measurement branch) you must press the following sequence of icons:

1. Touch the  icon to display the Main Menu screen.
2. Next, touch the  icon to display the Measurement screen.
3. Finally, touch the  icon to display the Alarms screen.

This sequence is shortened in the manual and will appear above the screen page as:





Familiarity of the icons below will allow easier navigation of the menus.

Icon	Meaning	Function
	Home	Returns to the Home screen.
	Main Menu	Displays the Main Menu screen that contains the four main branch icons: Measurement, Diagnostics, Maintenance, and Settings.
	Next	Displays the next set of functions onto the screen. The new list will always appear in a new column to the right of the arrow.
	Return	Returns to the prior screen.
	Accept	Touch this icon to accept any changes made.
	Cancel or Exit	Touch this icon to cancel or reject any changes made or exit a screen.
	Not Active	In several menus this icon is used to deactivate the selection.
	Active	In several menus this icon is used to activate the selection.



## 5.4 Touchscreen and Navigation overview

Each screen displays active icons that are relevant to that screen's operation. To select an icon, it is best to use the eraser end of a pencil or a stylus to touch the icon on the screen graphic.

*Note: Be sure not to press too hard or you will damage the screen; do not use the point of a pen or pencil to touch the screen.*

For example, the sequence used to arrive at the screen shown in Figure 5-3 is accessed by touching the Main Menu icon  on the Home page then touching the Measurement icon  to activate the first set of the Measurement choices.



The Measurement choices available are shown in Figure 5-3 and show up as icons in the column to the right of the Main Menu list. The  icon background now turns blue  indicating it is the active Main Menu choice as you navigate forward through the various choices.

*Note: The Main Menu branch stays visible all the time unless you are in a special screen or the Home page. This allows you to access the other Main Menu choices easily.*



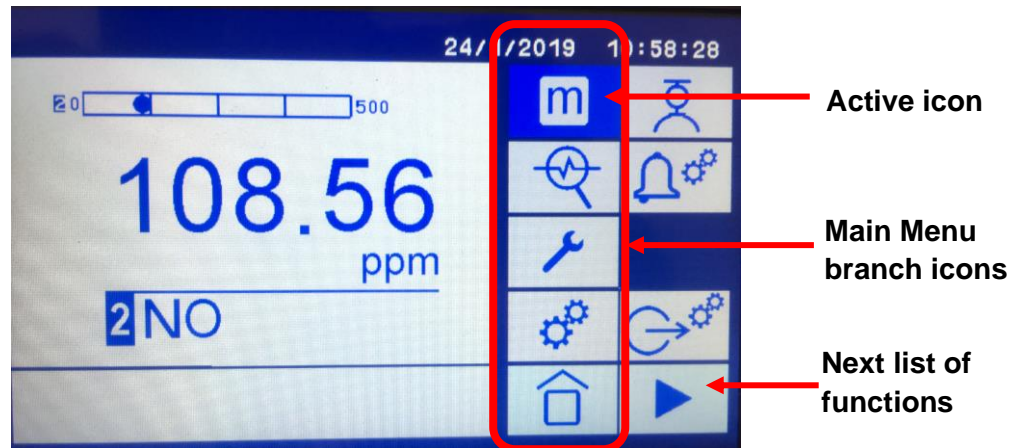

**Figure 5-3: The user interface of the Main Menu screen with the Measurement branch active.**

When a Main Menu icon is selected further icons associated with that function are displayed as seen in Figure 5-3. New icons associated with that function will appear to the right of the icon just touched or it may transfer you to a new screen.

In the case of the Main Menu Branch icons, if there are more functions associated with the main function activated and they do not all fit onto one screen then the  Next List key will be present in the lower right corner or on the bottom of the list. When touched, more functions will appear in a new list to the right of the old list for selection.



The Main Menu Branch will remain visible as the farthest column on the left. Details are shown later in this section.

Figure 5-4 shows a Step Series of Screens that are launched when the Settings Main Menu icon  is touched:



- The first series of functional icons that belong to the Settings section are displayed in the column of icons to the right of the Main Menu icons (Figure 5-4 A).



- To display the next set of functions touch  which brings up the second set of Setting functions (Figure 5-4 C) to the right of the first set (Figure 5-4 A). Note that  is activated as the background color is now blue (Figure 5-4 B).



- To get the third and final set of functions touch  at the bottom of the list of the last column (Figure 5-4 C) and the third set of icons will replace the second set in the final column position (Figure 5-4 D).



- To return the second set of features touch the Return icon  at the top of the last column and the middle screen in Figure 5-4 will be returned.

*Note: When the Return icon is touched the Main Menu icon no longer has a blue “activated” background. The icons displayed are still associated with the original main menu icon selected, but the Return button removes the Main Menu background on some of the icons.*

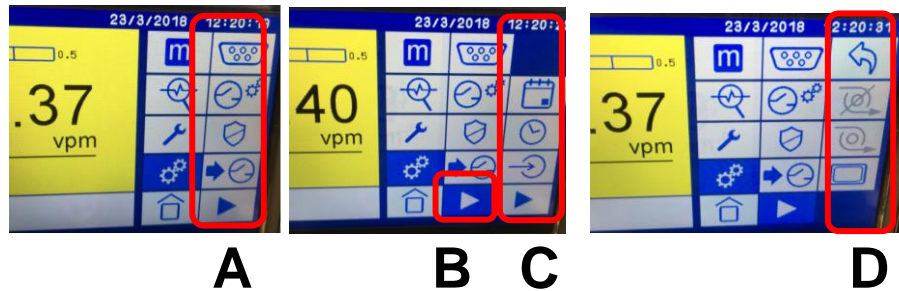

**Figure 5-4: The User Interface Menu screen with the Settings branch activated**

*Note: The Main Menu branch stays visible all the time even while navigating through the three sets of functional icons of the Settings branch. In this case, the first set of icons also remain visible and only the third column of icons is replaced when the Next List icon is touched.*

## 5.5 Home screen

The Home screen (Figure 5-5) displays the current measurement and system status.

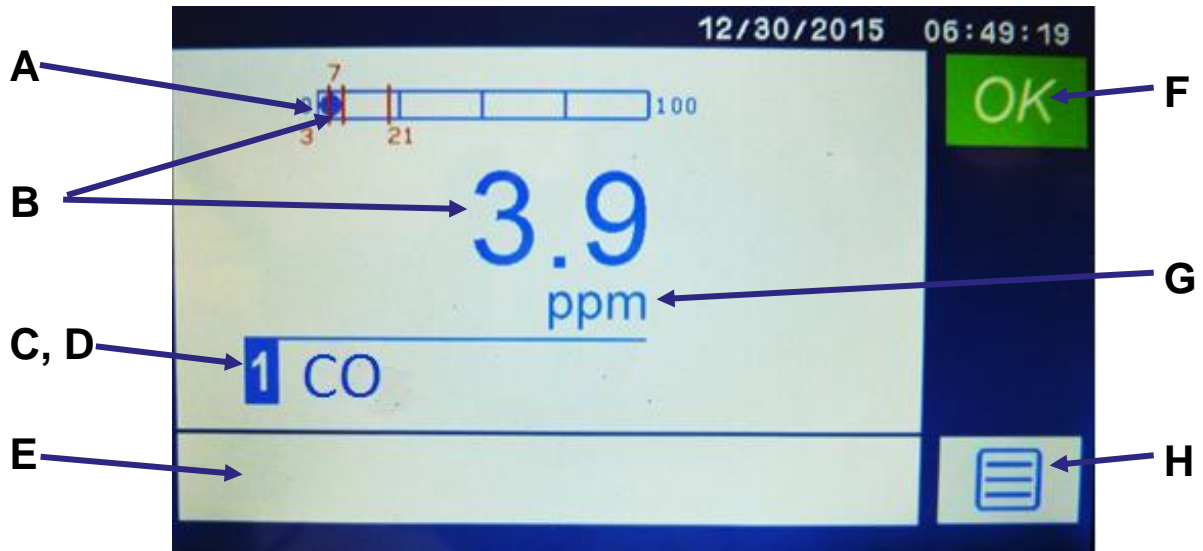

Figure 5-5: Single Gas Home screen components

- |   |   |   |  |
|---|---|---|--|
| A | Bar graph showing the operable measurement range boundaries, current measurement and relative to alarm set points | E | Information area where messages such as error codes, IP address, and diagnostic information are displayed. |
| B | Current measurement   | F | System status  |
| C | Transducer number<br><i>Note: 1 is always shown.</i>  | G | Measurement units  |
| D | Analyte being measured  | H | Menu icon  |

**Hint:** If no icon is pressed for 1 minute in any other menu branch, Home screen is automatically displayed. You will also then have to re-enter your password to access any password-protected screens. The "Home screen return" value can be increased in the Settings Menu from 1 to 3 or 5 minutes.

## 5.6 Main Menu screen icons

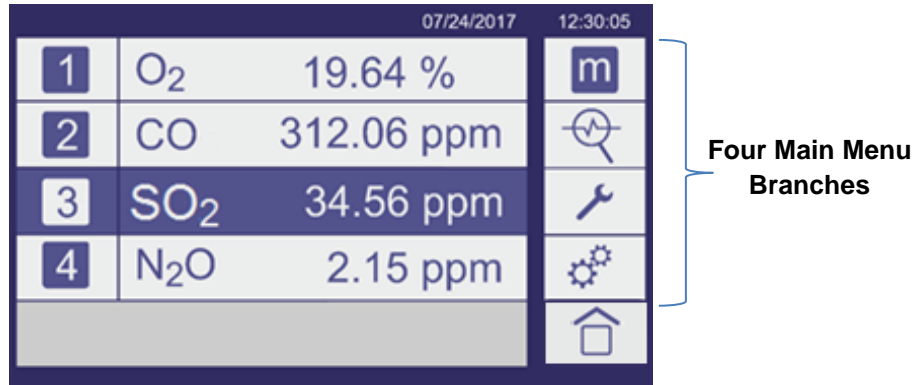

Figure 5-6: Menu screen

The Main Menu icons are listed below:













Icon	Meaning	Function
	Measurement	Displays the Measurement screen where measurement, calibration / validation and alarm settings can be adjusted for each transducer installed (Section 6).
	Diagnostics	Displays the Diagnostics screen where system-wide diagnostic tools can be found (Section 7).
	Maintenance	Displays the Maintenance screen where system-wide maintenance actions can be initiated (Section 8).
	Settings	Displays the Settings screen where system-wide parameters can be defined (Section 9).
	Home	Touch this icon to return to the Home screen (Section 5).

*Note: The first column of icons on each menu screen is the same for all analyzers. Once one of the four menu branches are selected that relevant icon background changes blue to show which menu screen is active (see Figure 6-1 below).*

## 5.6.1 Frequently Used Touchscreen icons

The following table shows touchscreen icons that frequently appear on different screens. The Main Menu Icons are highlighted as bold text under the “Meaning” column below.

**Table 5-1: Frequently Used Touchscreen icons:**

Icon	Meaning	Function
	Menu	Located on the Home screen (Figure 5-2) displays the Menu screen of the four branches when touched.
	<b>Measurement</b>	Displays the first set of functional icons associated with the Measurement activities (Figure 5-3).
	<b>Diagnostics</b>	Displays the first set of functional icons associated with the system-wide Diagnostics tools that can be activated.
	<b>Maintenance</b>	Displays the first set of functional icons associated with the system-wide Maintenance operations that can be activated.
	<b>Settings</b>	Displays the first set of functional icons associated with configuring the system-wide parameters Settings including the Relays.
	Calibrate	Displays the first set of functional icons associated with configuring the various Calibrate functions and activities.
	Alarm settings	Displays the first set of functional icons associated with configuring the system-wide Alarm parameters and actions.
	Home	This icon is used to return back to the Home screen showing the gas transducer concentration values.
	Accept	Touch this icon to accept any changes made.
	Cancel or Exit	Touch this icon to cancel or reject any changes made or exit a screen.
	Next List	Touch this icon to display the next set of functional icons onto the screen.
	Return	Touch this icon to return to the prior screen.

*Note: The four main menu branches are shown in **bold** in Table 5-1.*

## 5.7 System and measurement status icons and notices

The Status icon is located at the top right corner of the Home screen. If the system is operating correctly the green OK icon is displayed (Figure 5-).



**Figure 5-7: Home screen (three gas transducers)**

*Note: If you touch the green OK icon it will display the date and time when the analyzer was last started.*

If a problem occurs with the system, the Status icon changes to one of the symbols shown in the table below.



Icon	Meaning	Meaning
	Alarm	Indicates that there is an alarm on the system. Touch the icon to display the Alarm Selection screen. An example is shown in Figure 5-.
	Faults	Indicates a fault with the transducer or analyzer: a communication failure with the transducer, an over-temperature condition, or out of specification where the measured value is out of the maximum range for the transducer (see Figure 5-). Touch the icon to display a message in the text bar describing the fault.



Figure 5-8: Home screen (3 transducer analyzer), showing O<sub>2</sub> alarm



Figure 5-9: Home screen (3 transducer analyzer), showing warning screen with fault description

Note: In Figure 5- the Calibration icon  was touched and “Reading: 20.02” was displayed at the bottom of the screen indicating the O<sub>2</sub> value is out of specification.

# 6 Analyzer Menu Branch Structure

## 6.1 Menu branch structure

Section 6.1.1 describes the top-level Main Menu structure and directs you to the subsections that show the buttons available under each of the main menu branches.

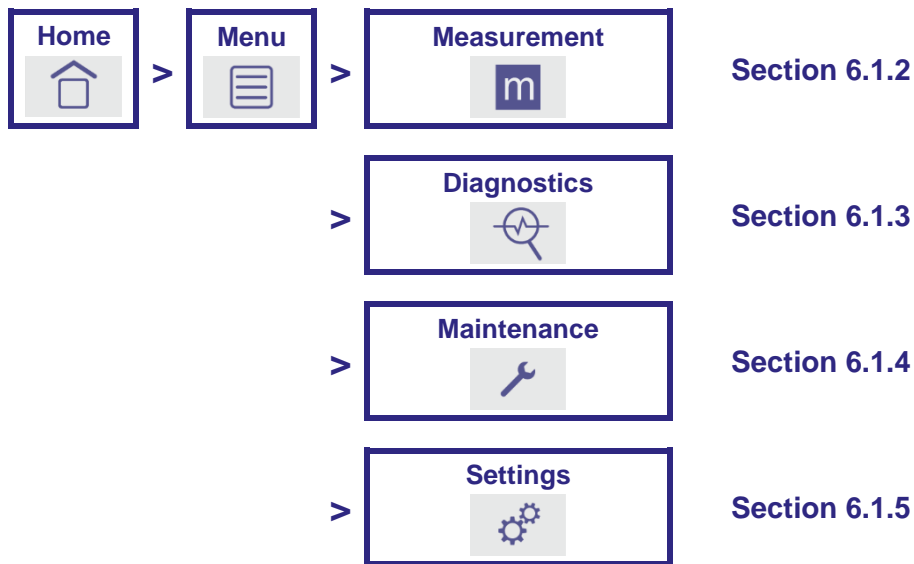

The tables in Sections 6.1.2 to 6.1.5 show the substructure buttons available for each of the Main Branches. For example, once you navigate to one of the Main Branches (Measurement, Diagnostics, Maintenance, or Settings) press the Level 1 button to display the associated Level 2 buttons; press a Level 2 button to display the associated Level 3 buttons, etc. Levels beyond 4 are provided in the detailed sections of the manual only. Shaded areas show that there are no available buttons at that level.

### 6.1.1 Top level structure





















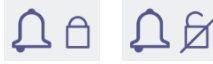













### 6.1.2 Measurement











*Note: Each Alarm and Relay have their own settings. Only one set is shown as example.*















Measurement Level 1 Button	Measurement Level 2 Button	Measurement Level 3 Button	Measurement Level 4 Button
<b>Manual Calibration</b> 	<b>Span Setup</b> 	<b>Set &amp; Run Span Calibration</b>	
	<b>Zero / Low Span Set-up</b> 	<b>Set &amp; Run Zero / Low Calibration</b>	



















Measurement Level 1 Button	Measurement Level 2 Button	Measurement Level 3 Button	Measurement Level 4 Button	
<b>Manual Calibration (cont.)</b> 	<b>Reset Calibration</b> 	<i>Supports CO<sub>2</sub>% and CO% Transducers only</i>		
<b>Alarms</b> 	<b>Meas. Value alarm</b> 	<b>Meas. Value High</b> 		
		<b>Meas. Value Low</b> 		
		<b>Meas. Alarm Value Threshold</b> 		
		<b>Meas. Alarm Value Hysteresis</b> 		
		<b>Audible Alarm On / Off</b> 		
		<b>Alarm Following On / Off</b> 		
		<b>Alarm Latching On / Off</b> 		
		<b>Flow Alarm</b> 		
		<b>Alarm Off</b> 		
		<b>Audible Alarm On / Off</b> 		
<b>Alarm Following On / Off</b> 				

Measurement Level 1 Button	Measurement Level 2 Button	Measurement Level 3 Button	Measurement Level 4 Button
Alarms (cont.) 	Flow Alarm (cont.) 	Alarm Latching On / Off  	
	Transducer Temp Alarm 	Alarm Off 	
		Transducer Temp Value High 	
		Transducer Temp Value Low 	
		Transducer Temp Alarm Value Threshold 	
		Transducer Temp Alarm Value Hysteresis 	
		Audible Alarm On / Off  	
		Alarm Following On / Off  	
		Alarm Latching On / Off  	
		Alarm Off 	







Measurement Level 1 Button	Measurement Level 2 Button	Measurement Level 3 Button	Measurement Level 4 Button
<b>Analog Output Adjustment</b> 	<b>Analog Output Range Setting per Tx</b> 	<b>Expanded User Range</b> 	
		<b>User High Range Value</b> 	
		<b>User Low Range Value</b> 	
		<b>Auto Range On / Off</b> 	
		<b>Analog Output Settings</b> 	<b>Follow Meas Value During Cal On / Off</b> 
			<b>mA Output adjust</b> 
			<b>Jam Condition Zero</b> 
			<b>Jam Condition 2 mA</b> 

Measurement Level 1 Button	Measurement Level 2 Button	Measurement Level 3 Button	Measurement Level 4 Button
			<b>Jam Condition</b> <b>21.5 mA</b> 
			<b>Jam Condition None</b> 
			<b>Check Range Validity</b> 
<b>Show Transducer Temp</b> 			
<b>Measurement Record</b> 	<b>Choose Time interval</b> 		
	<b>Trash / Delete Data</b> 		
<b>Data Filtering</b> 	<b>Filter Type 1</b> 		
	<b>Filter Type 2</b> 		
	<b>Filter Type 3</b> 		
	<b>Filter Type 4</b> 		
	<b>Filter Type 5</b> 		
	<b>Filter Type 6</b> 		



Measurement Level 1 Button	Measurement Level 2 Button	Measurement Level 3 Button	Measurement Level 4 Button
	<b>Filtering Off</b> 		
<b>NO<sub>x</sub></b>	<b>NO<sub>2</sub> 2.5% Total NO<sub>x</sub></b> 		
	<b>NO<sub>2</sub> 5.0% Total NO<sub>x</sub></b> 		
	<b>Activate / Deactivate</b> 		
<b>Transducer Firmware Rev</b> 			
<b>Transducer Serial Number</b> 			
<b>Auto-Cal Settings</b> 	<b>Transducer Sequence Selection (#1, #2, #3)</b> 	<b>Auto-Validation Setup</b> 	<b>Run Auto-Validation Now</b> 
			<b>Abort Auto-Validation</b> 
			<b>Set Auto-Validation Date / Time / Repeats</b> 
			<b>Auto-Calibration Setup</b> 
			<b>Run Auto-Calibration Now</b> 
			<b>Abort Auto-Calibration</b> 



Measurement Level 1 Button	Measurement Level 2 Button	Measurement Level 3 Button	Measurement Level 4 Button
			Set Auto-Calibration Date / Time / Repeats 
Transducer Diagnostics 			

### 6.1.3 Diagnostics











Diagnostics Level 1 Button	Diagnostics Level 2 Button	Diagnostics Level 3 Button	Diagnostics Level 4 Button
Software revision 			
Analyzer Electronic Temp 			
Analyzer SN 			
System File Save 			
Relay Test 	Open / Close Relay  		
Display System Log <i>Sys Log</i>			
Display Calibration Log <i>Cal Log</i>			
Fault Inquiry 			

### 6.1.4 Maintenance

Maintenance Level 1 Button	Maintenance Level 2 Button	Maintenance Level 3 Button	Maintenance Level 4 Button
Update Firmware 			
Disk Management 			

Maintenance Level 1 Button	Maintenance Level 2 Button	Maintenance Level 3 Button	Maintenance Level 4 Button
<b>Upload System Settings Files</b> 			
<b>Clear Errors</b> 			





### 6.1.5 Settings











Settings Level 1 Button	Settings Level 2 Button	Settings Level 3 Button	Settings Level 4 Button
<b>Serial Port Setup</b> 	<b>RS232</b> 		
	<b>RS485</b> 		
	<b>Full Duplex</b> 		
	<b>Half Duplex</b> 	RS485 only	
	<b>1 Stop Bit</b> 		
	<b>2 Stop Bits</b> 		
	<b>Baud Rate Setting</b> 	1200, 1800, 2400, 4800, 9600, 19200, 38400, 76800, 115200	
	<b>Parity</b> 	None Even Odd	
	<b>Serial ID</b> 		
	<b>RS485 Only Functions</b>	Delta F Legacy 485 	

















Settings Level 1 Button	Settings Level 2 Button	Settings Level 3 Button	Settings Level 4 Button
		<b>Modbus</b> 	
		<b>Off</b> 	
		<b>Streaming</b> 	

<b>Serial Port Setup</b> <i>(cont.)</i> 	<b>RS485 Only Functions</b> <i>(cont.)</i> 	<b>Output Frequency</b> 	
		<b>Modbus Word Swapping: On / OFF</b> 	
		<b>Select Transducer Measurement #1, #2, etc.</b>	
		<b>Transducer Alarm</b> 	
		<b>“Service in Progress”</b> 	
		<b>Transducer Fault Alarm</b> 	
		<b>Range Change</b> 	
		<b>External 4-20mA Alarm</b> 	
<b>Relay Assignment</b> 	<b>Alarm Assignment</b> 		<b>External Hi / Low Alarm</b> 









Settings Level 1 Button	Settings Level 2 Button	Settings Level 3 Button	Settings Level 4 Button
<b>Password Setup</b> 	<b>Master</b> 		
	<b>Operator</b> 		
	<b>Keystroke Recording On / Off</b> 		











<b>Manual Relay Override</b> 	<b>Normal Operation – Relay ON</b> 		
	<b>Normal Operation – Relay OFF</b> 		
	<b>Forced ON Operation – Relay ON</b> 		
	<b>Forced OFF Operation – Relay OFF</b> 		
<b>Analyzer Date</b> 	DD, MM, YYYY		
<b>Analyzer Time</b> 	HH:MM:SS		
<b>Input Setup</b> 	<b>Analog Inputs</b> 	<b>Specific Analog Input</b> 	<b>Low Value</b> <i>Text input</i>
			<b>High Value</b> <i>Text input</i>
			<b>Units</b> <i>Text input</i>

Settings Level 1 Button	Settings Level 2 Button	Settings Level 3 Button	Settings Level 4 Button
			<b>Display Text / Analyte / Device</b> <i>Text input</i>
			<b>Record Analog Input</b> 
			<b>Set Alarm (High, Low, Threshold, Hysteresis)</b> 

<b>Input Setup (cont.)</b> 	<b>Analog Inputs (cont.)</b> 	<b>Specific Analog Input (cont.)</b> 	<b>Analog Input On / Off</b> 
	<b>Digital Inputs</b> 	<b>Specific Digital Input for assignment</b> 	<b>Choose Transducer 1,2,3,4 (right side)</b>
			<b>Choose mA Input Contact Closure (left side)</b> 
			<b>Start Auto-Cal</b> 
			<b>Stop Auto-Cal</b> 
			<b>Start Low / Zero Cal</b> 
			<b>Start Span Cal</b> 
			<b>Declare Analog Input is in Cal</b> 
			<b>Declare Analog Input is OK</b>

Settings Level 1 Button	Settings Level 2 Button	Settings Level 3 Button	Settings Level 4 Button
			Ext OK
			Disable Digital Input ✕
<b>Pump On / Off</b> 	<i>Not available on MultiExact 4200</i>		
<b>Concentration Units</b> units	ppm		
	mg/m <sup>3</sup>		

<b>Network Settings (Modbus TCP/IP)</b> 	Off		
	IP Static		
	DHCP Active		
<b>Screen View</b> 	<b>Single / Split Screens</b> 		
	<b>Increase / Decrease Screen Brightness</b> 		
	<b>Screen Dim Timer</b> 1, 3, 5 min		
<b>Analog Output Adjustment</b> 	<b>Analog Output Range Setting</b> 	<b>Expanded User Range</b> 	
		<b>User High Range Value</b> 	

Settings Level 1 Button	Settings Level 2 Button	Settings Level 3 Button	Settings Level 4 Button
		User Low Range Value 	
		Auto Range On / Off 	
		Analog Output Settings 	Follow Meas Value During Cal On / Off 
			mA Output adjust 
			Jam Condition Zero 
			Jam Condition 2 mA 
			Jam Condition 21.5 mA 
			Jam Condition None 
Global Block Averaging 	Block Time Constants Off, 1 sec, 2 sec, 5 sec, 10 sec, 20 sec, 30 sec, 60 sec, 120 sec		

## 7 Measurement branch screens



The Measurement branch has four pages of icons (shown in Figure 7-1 to Figure 7-4). Touch the Measurement icon to see the first page of icons appear on the right of the Measurement icon (Figure 7-1). Touch the Next  icon and a new column of active icons will appear over the last column on the right.

*Note: The measurement selected determines the active settings and diagnostics functions. Not all of the features are available to every transducer type, so some screens may look different depending upon the allowed features.*

*Note: Page 1 displays first.*

*To go to the subsequent pages, press the  icon.*

*To go back to the previous page, press the  icon.*

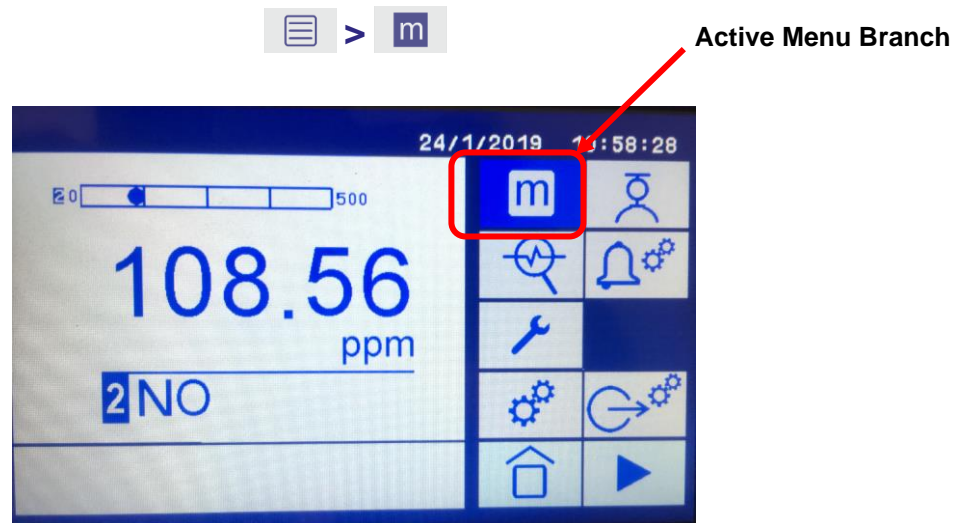

Figure 7-1: Measurement screen – page 1



Figure 7-2: Measurement screen - page 2



Figure 7-3: Measurement screen – page 3



Figure 7-4: Measurement screen – page 4

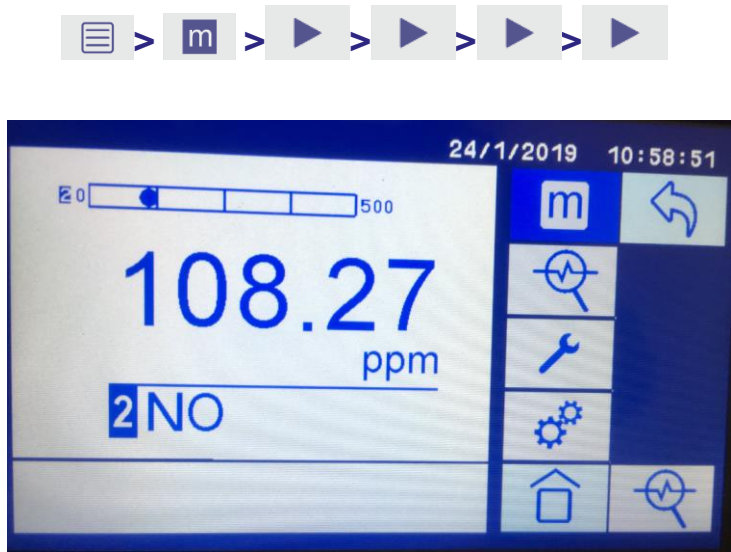













Figure 7-5: Measurement screen – page 5



**Table 7-1: The Measurement branch icons and their actions**

Icon	Meaning	Function
	Manual Calibration Settings	Used to define the manual calibration / validation limit settings for each of the transducers (see Section 11 for details).
	Transducer Diagnostics	Reads and then displays on screen the current transducer diagnostics.
	Alarm Settings	Used to configure and define the measurement alarm settings for each of the transducers. Two of the eight alarms are activated with each transducer ordered (see Section 7.2 for details).
	Analog Output Adjustment	Use this to adjust range settings and set the analog output parameters for the selected measurement
	Transducer Temperature	This feature measures and displays the transducer temperature in the text box at the bottom of the screen.
	Measurement save	Used to start recording measurement values to the analyzer. Data must be saved to a USB drive to view and must also be deleted from the analyzer by the user.
	Data Smoothing Filtering	Use this to filter noisy data by applying short, medium and long filters. Default is to apply no filter.
	Derived NOx measurement	Use this to activate and select the required derived Total NOx as NO2 measurement
	Transducer firmware revision	Displays the currently selected gas transducer firmware revision in the text box at the bottom of the screen.
	Transducer serial number	Displays the currently selected gas transducer serial number in the text box at the bottom of the screen.
	Auto-Cal Sequence settings	Used to set up the auto-calibration / auto-validation parameters per selected transducer when this option is purchased (see Section 11 for details).

Icon	Meaning	Function
	Transducer Diagnostics	Reads and then displays on screen the current transducer diagnostics.

*Note: The transducer firmware revision, temperature, and serial number display in a text box at the bottom of the screen when the relevant button is pressed. The information is valid for the specific gas transducer that was selected.*

*Note: The Manual calibration and validation descriptions and settings are described later in the manual in Section 11 along with the Auto-Cal optional features.*

## 7.1 Configuring manual calibration and Auto-Cal sequences

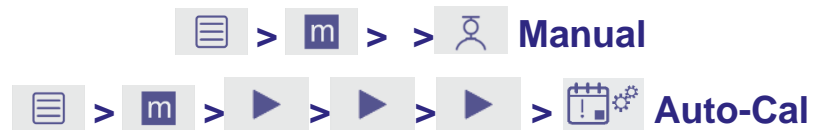

The sequence of icons to touch to access the manual calibration and auto calibration configuration pages are shown above. See Section 11.5 and Section 11.6 for details on how to set up the Manual calibration and the Auto-Cal Sequences.

## 7.2 Configuring the measurement alarms

### 7.2.1 Display the Measurement Alarms Screen



The Alarms screen shows how each of the eight alarms is currently configured. The standard analyzer is supplied with 2 alarms for each transducer, and a further 2 or 6 alarms per transducer can be optionally purchased. Figure 7-6 shows a CO transducer where the option for 8 total alarms has been purchased. Note that none of the alarm bells are grayed out. Alarm #1 is set to High Alarm, Alarm #3 is set to Low Alarm, Alarm #2 is set to the Low Flow Alarm. Alarms 4, 5, 6, 7 and 8 are not yet configured.



Figure 7-6: Alarms screen showing CO with 8 alarms available: #1, #2, #3 have already been configured.

*Note:* During a calibration, an alarm will only be activated if the alarm 'Follow'  option is selected (see Section 7.6).

### 7.2.2 Configuring the Measurement Alarm settings



The Analyzer alarms can be configured to operate in one of four modes: Measurement alarm, Flow alarm, Span / Reference alarm, and Transducer Temperature alarm. Each transducer can be configured with multiple alarms.

To configure the alarm:

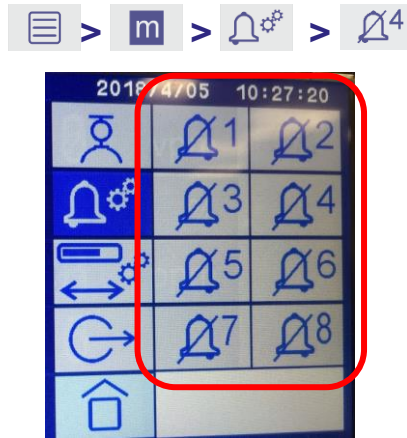
1. Touch the Alarm Setup icon to see the available alarms (See Figure 7-7). Touch the icon for the selected alarm.



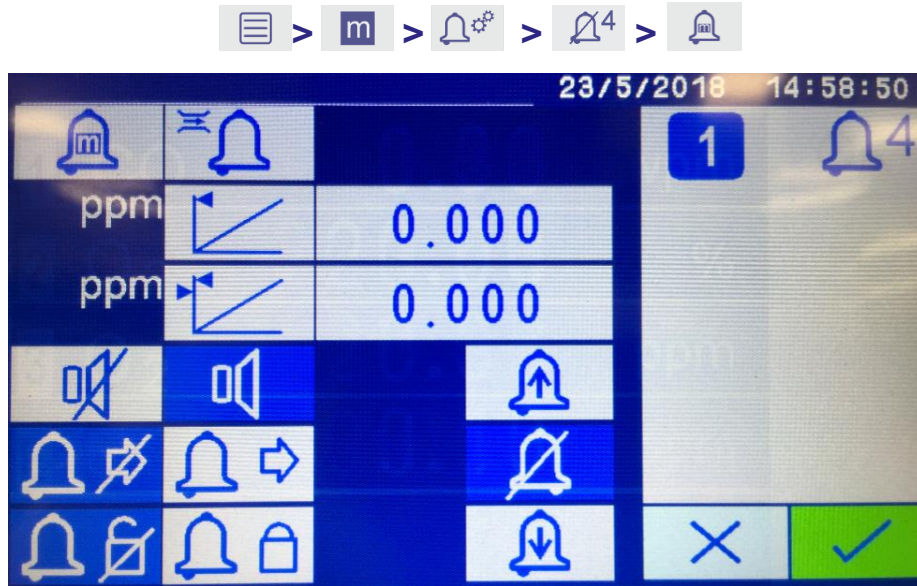

**Figure 7-7: Alarm icons on alarm screen**

- The Alarm setup screen for the selected alarm is displayed. Figure 7-8 shows Alarm #4  configured for a Measurement Alarm on Transducer #1 .



**Figure 7-8: Measurement Alarm setup screen for Transducer #1 and Alarm #4**

In Figure 7-8 the following alarms have been set or deactivated: Audible alarm is on , Do Not Follow  is on, Do Not Latch  is on and no Measurement value alarm (Hi or Lo)  has been selected.

*Note: Most of the icons are paired with the Deactivate and Activate icon next to the Alarm icon on the same row. The exceptions are the High  and Low  Measurement Alarm icons that are located at the bottom right side with the deactivate  icon between them in a column.*

Note: Touch the Accept  icon to accept the new configuration, otherwise the configuration will revert back to the original settings.





**Figure 7-9: Measurement Alarm setup screen for Transducer #1 and Alarm #1**

In Figure 7-9 the following alarms have been set or deactivated: Audible alarm is off , Do Not Follow  is on, Do Not Latch  is on and the Hi Measurement value alarm  has been selected.

Note: Figure 7-8 and Figure 7-9 show examples of the different options available for specific transducers or system.













3. Press the required icon on the row horizontally across the top of the screen to either configure or activate the alarm as the main alarm function.

**Table 7-2: Measurement Alarm Main icons**

Icon	Meaning	Function
	Measurement Alarm	Alarm is activated when a measurement concentration or condition exceeds the limits set in the alarm mode screen.
	Flow Alarm	Activates the optional flow switch alarm when the flow drops below 0.1 L/min (the default location is on stream #1 for dual streams).
	Transducer temperature alarm (IR1520 transducers only)	Alarm condition is activated when the transducer temperature exceeds 45°C. If the transducer temperature exceeds 45°C for 30 minutes, the transducer automatically turns off.

4. Table 7-3 shows the available alarm functions and descriptions, some of which can be used together on the same alarm.

**Table 7-3: Measurement Alarm Sub-Branch icons**





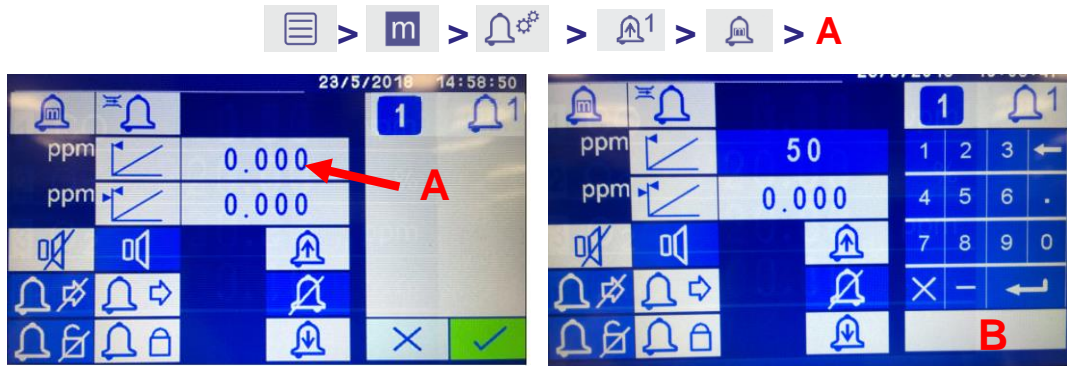

Icon	Meaning	Function
	Alarm Mode available but deactivated	Alarm available but is not configured to activate under any condition. Can use this to quickly remove an alarm configuration that had been previously assigned.
	Alarm Mode Low	Alarm will be activated when a sample measurement is lower than the pre-set alarm level.
	Alarm Mode High	Alarm will be activated when a sample measurement is higher than the pre-set alarm level.
	Alarm Value Threshold	Set the value at which the High or Low alarm will be activated.
	Alarm Value Hysteresis	These values determine when an activated measurement alarm condition will be deactivated.
	Audible Alarm Mode is On	Activates the audible alarm so the alarm sounds when the alarm limit is triggered.
	Audible Alarm is deactivated	Deactivates the audible alarm. Also used to silence the alarm when the Audible Alarm Mode is On and has been triggered.
	Alarm Following	Activates the alarm during a calibration. If the alarm threshold is reached the alarm will sound.
	Alarm Following deactivated	Deactivates the alarms during a calibration. This is the default mode.
	Alarm Latching	The alarm condition remains activated (both visible and audible) until the alarm is manually deactivated (see  below).
	Alarm Latching deactivated	The alarm condition remains activated until the sample measurement value falls within the normal limits, at which point the alarm is automatically deactivated.  This icon is also used to deactivate all Alarm Latching conditions.

### 7.2.3 Threshold levels







The Threshold Level  is the value at which the measurement will trigger the alarm. To set the Threshold value for the high or low alarms for the measurement range of the transducer use the following sequence (specific example below is for Alarm #1 setting the High Alarm):



**Figure 7-10: Alarm Threshold values set by pressing (A) and number key pad (B).**

1. Touch the number to the right of the  icon as shown in Figure 7-10 A.
2. Use the number keypad shown in Figure 7-10 B to type in the threshold value then press  to accept the value or  to cancel the entry.
3. To save the alarm settings to the current alarm, press the  icon shown in the left screen in Figure 7-10 A.
4. To abort the changes and return to the original settings prior to entering the Alarm Setting screen, press the  icon. This icon appears in place of the Return icon  in Figure 7-10 A if changes have been made to the settings.

**Table 7-4: Navigation tools in the Alarm Threshold screen**

Icon	Function
	Touch this icon to delete the last digit typed in.
	Touch this icon to accept the value entered in the keypad.
	Touch this icon to return to the previous screen. When setting has been changed this icon is replaced by  .
	Touch this icon to accept all the alarm settings.
	Touch this icon to cancel the entered value on keypad or setting change on the Alarm Setting screen.

5. Figure 7-11 displays the alarm setting thresholds on the home screen as red lines and text on the bar graph at the top of the screen.
6. Once the alarm setting has been configured you may now assign a relay to that alarm (Section 10).
7. Repeat this for each alarm as required.

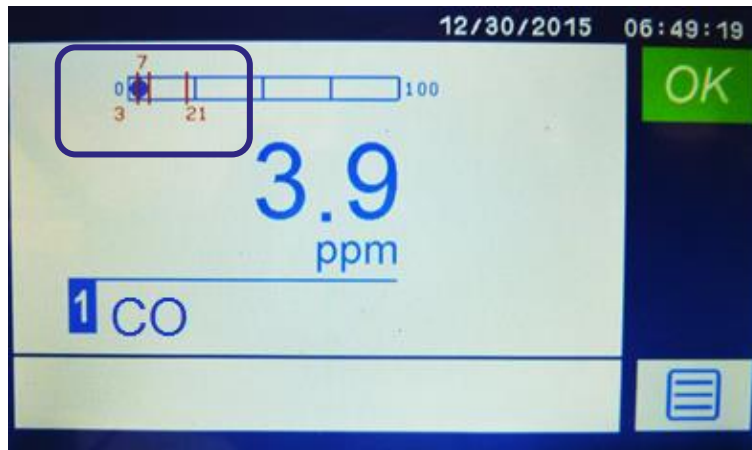

**Figure 7-11: Home screen showing alarm settings as red lines and text on the bar graph**

#### 7.2.4 Hysteresis levels



The Hysteresis level  associated with a measurement alarm determines when an activated alarm condition is deactivated. A single value is entered into the Hysteresis level and it will be applied to the Measurement Alarm limit depending on the alarm mode selected as described below.

**Table 7-5: Alarm modes and hysteresis effects**

Alarm mode	Effect of hysteresis
Low alarm	Once the low alarm condition has been activated, the alarm condition will not be deactivated until the value of a sample measurement is above the low alarm level + hysteresis level.
High alarm	Once the high alarm condition has been activated, the alarm condition will not be deactivated until the value of a sample measurement is below the high alarm level – hysteresis level.





Note: We designate a percent level concentration value as “%-vol” and a percentage calculation of a range as “%”.

Note: The Measurements Alarm levels can be reported as a percentage (%) of the measurement range or as a fixed concentration value (in ppm, mg/m<sup>3</sup> or %-vol) depending upon the transducer installed and the user preferential settings. The Hysteresis levels are set as a fixed concentration value.

**Examples:**

- a. If a 'Low' alarm has an alarm level of 15 %-vol and a hysteresis level of 1 %-vol, the alarm is activated when a sample measurement is < 15 %-vol, and the alarm is not deactivated until a sample measurement is > 16%-vol.
- b. If a 'High' alarm has an alarm level of 3 ppm and a hysteresis level of 1 ppm, the alarm is activated when a sample measurement is > 3 ppm, and the alarm is not deactivated until a sample measurement is < 2 ppm.

To set the Hysteresis level  associated with a measurement alarm use the following sequence (specific example below is for Transducer #1 and Alarm #1):

1. Touch the number to the right of the  icon as shown in Figure 7-12 A.
2. Use the number keypad shown in Figure 7-12 B to type in the threshold value.

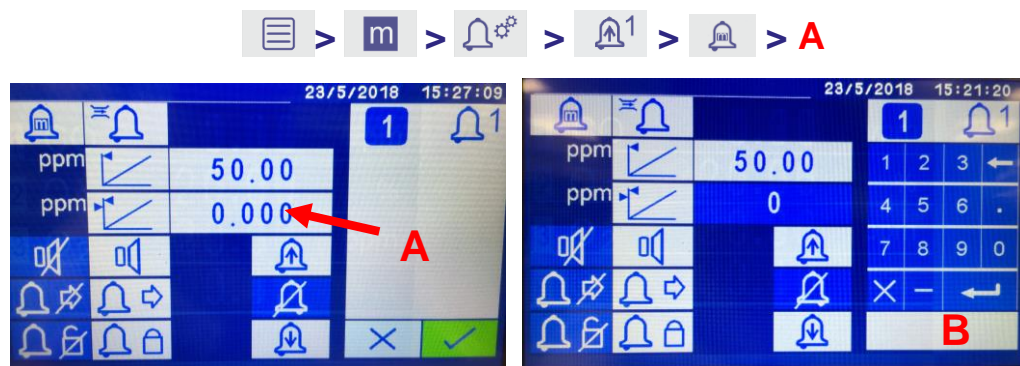

**Figure 7-12: Alarm Hysteresis values set by pressing (A) and number key pad (B).**

**Hint:** Ensure that the measurement alarm and hysteresis levels are not too close to the expected sample measurements. Otherwise minor and potentially acceptable variations in sample gas concentrations will result in spurious alarms.

**Hint:** If you configure one measurement alarm as 'low' and the other measurement alarm as 'high', ensure that the 'high' alarm with its hysteresis levels is higher than the 'low' alarm with its hysteresis levels. Otherwise, the analyzer can be permanently in an alarm condition until the hysteresis levels are adjusted.

## 7.2.5 Activated alarms details

When a measurement alarm condition is activated or triggered:

- The screen changes to flashing red (Figure 7-13).
- The Alarm Status icon appears at the upper right of the screen (Figure 7-13 A).
- The appropriate alarm relay will be triggered.



Figure 7-13: Measurement alarm condition triggered

Press the following sequence of icons to view the details of the activated alarm (Figure 7-14 A).



Figure 7-14: Alarms screen showing Alarm #1 (A) High Measurement Range triggered

## 7.3 Configuring the User Ranges for mA Output and Screen Display

Each gas transducer has a predefined range based upon the intrinsic measurement range that was purchased. Dual ranges can be set up on the transducer to provide more precision using the User Low Range, User High Range and the User Expanded Range settings. With the auto-range function, both the display and output signals will follow those ranges. The default settings are based upon the intrinsic measurement of the purchased transducer. The range limits will be displayed on the bar at the top of the measurement screen for each of the transducers (see Figure 7-15 as an example).

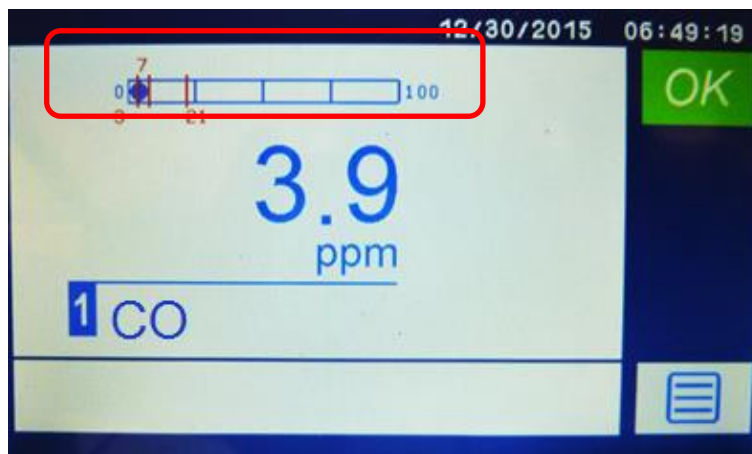



Figure 7-15: Measurement Screen - Alarm Limits (in red) on Range Limit bar

### 7.3.1 The Analog Output Range Setting screen

To make any changes press the following sequence from the Home page to get to the Analog Output Range Setting configuration panel in Figure 7-17:



Touch  to reach the screen shown in Figure 7-16. Select the measurement to be configured by touching the appropriate "Tx #". For example, in Figure 7-16 the measurement "Tx #2" has been selected and is highlighted. Touch  to enter the "Analog Output Range Setting" configuration screen (see Figure 7-17). This screen allows configuration of Auto-ranging (activated icon highlighted in the red box A) and User expanded Range values (shown in red box B).

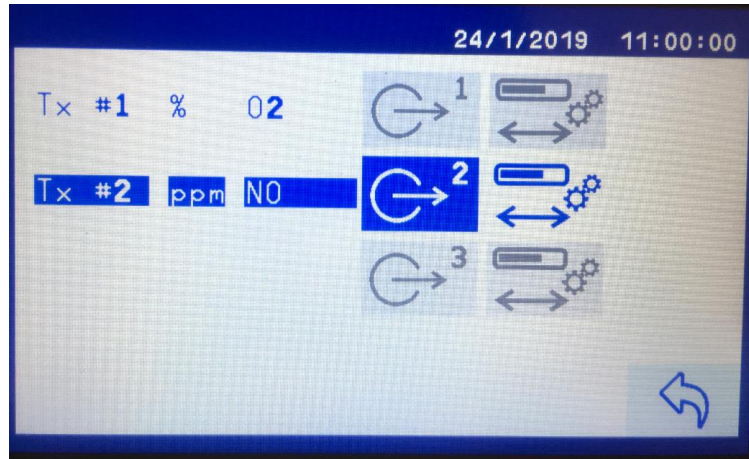

Figure 7-16: Select measurement (Tx #) for range setting

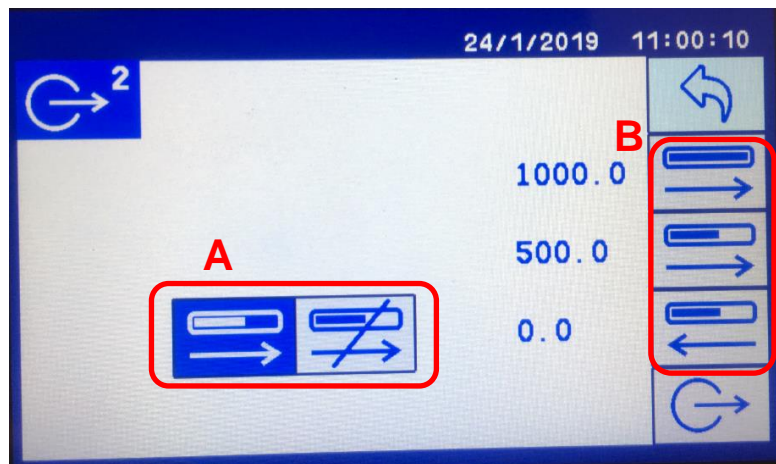



Figure 7-17: Analog Output Range Setting screen

Note: Several of the icons on this screen look the same (  ) but have very different functions. Please use the guidance in the document and Figure 7-17 as to which icon represents the various functions.

Note: More than one mA output may be assigned to a measurement (Tx #) provided an additional option board is ordered. Each mA output will require its range setting to be configured.

**Table 7-6: User mA Output and Display Measurement Range Setting Icons**









Icon	Meaning	Function
	Auto-Range Activation / Deactivation	Auto-range defines how the measurement output values are handled if multiple ranges are available (see icons position in Figure 7-17 A). Default mode is active.
	User Expanded Range (Over-Range) Value	Allows the user to set a new maximum “over-range” value that the serial output and analyzer display will reset to if the measurement value goes over the User High Range value. If this is not used the default is the intrinsic measurement range of the transducer (icon position at the top in Figure 7-17 B).
	User High Range Value	Sets the user defined range maximum measurement value that will be scaled to the serial output and analyzer display. If this is not assigned, the default is the intrinsic measurement range of the transducer (icon position in the middle in Figure 7-17 B).
	User Low Range Value	Sets the user defined range minimum measurement value that will be scaled to the serial output and analyzer display. The default User Low setting is 0 (icon position at the bottom in Figure 7-17 B).
	Analog Output Settings	Touch this icon to reach the analog output settings screen
	Return	Touch this icon to accept the Range settings and return to the previous screen.



Figure 7-18: Range values set using number key pad.

Table 7-7: Standard Navigation tools in the User Range Value screen

Icon	Function
	Touch this icon to delete the last digit typed in.
	Touch this icon to accept the value entered in the keypad.
	Touch this icon to cancel the value entered in the keypad.

### 7.3.2 Setting a Custom Expanded (over-range) Range Value



The User Expanded Range (or over-range) setting is used to define a new over-ranging maximum value that the serial output and analyzer display will reset to when the sample gas measurement value exceeds the User High Range value. This range will always be less than the intrinsic measurement range of the transducer and allows more precision across a smaller measurement range when over-ranging takes place.

To set a new User Expanded Range for the transducer, touch the  icon shown inside the red box labelled B in Figure 7-17 and use the numeric key pad in Figure 7-18 to enter the new maximum range value.

Once a new User Expanded Range  value is set, and the sample measurement value is above its maximum value, depending upon the analyzer settings the display and



the serial output may respond differently. See Section 7.3.6 for details and examples of how auto-ranging affects the values sent through the serial output and the analyzer display panel.

*Note: If you do not want the analyzer to report values above the User Expanded Range maximum value you need to turn auto-range OFF (ON by default).*

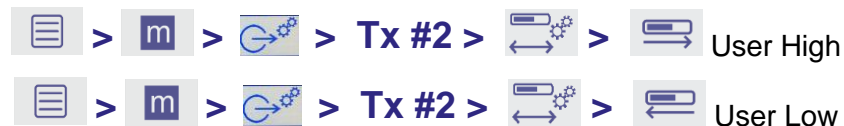
### 7.3.3 Setting a custom User High and User Low range



These settings are used to create a User defined measurement range for the transducer, lower than both the intrinsic measurement range and the User Expanded range, over which the serial output and screen displays will span and report. The default setting is the intrinsic measurement range but by using the User High Range and User Low Range settings the user can create a range that is lower than the intrinsic measurement range to provide greater precision.



The serial output range (4-20 mA or 0 – 10V) is determined by the minimum and maximum range values pre-set by the factory or they can be changed by the user with the User High Range  and User Low Range  icons located inside the red box labelled B in Figure 7-17. Use the numeric key pad shown in Figure 7-18 to enter the new range value.

If auto-ranging is active, the analyzer will automatically detect any over-range and switch to either the intrinsic measurement range or the User Expanded range value (if assigned). See Section 7.3.6 for details and examples of how auto-ranging affects the values sent through the serial output and the analyzer display panel.

*Note: If you do not want the analyzer to report values above the User High Range maximum value you need to turn Auto-range OFF (ON by default).*

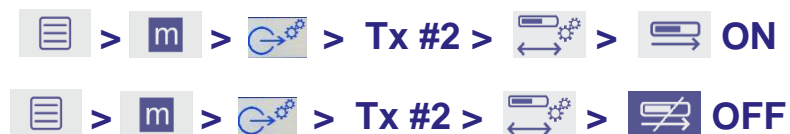
### 7.3.4 Auto-range ON/ OFF



The auto-range function is activated by pressing the auto-range  icon and it is deactivated by pressing the  icon. The icons are located at on the bottom middle of the screen shown inside the red box labelled A in Figure 7-17.

The auto-range function is used to define how the measurement output values are handled by both the serial output (mA or volts) and the analyzer display. If there are any User defined ranges (High, Low, Expanded), then the auto-range function will automatically determine which range to use.

When a measurement value goes over a User defined setting (User High Range and / or User Expanded Range), auto-ranging will switch the measurement range automatically to the higher range and re-scales the serial output (mA or volts) and the bar graph of the analyzer display panel.

*Note: If a measurement has auto-ranged above the User High Range maximum value to the higher User Expanded range or Intrinsic measurement range, the measurement value must fall to 10% below the User High Range maximum value before the auto-range switches back to the lower range. This prevents the output response from repeatably jumping between the two ranges.*

### 7.3.5 Range Setting Example

If you have a transducer with an intrinsic range maximum of 0-1000 ppm, but the process values never went above 100 ppm, you may want to define a new “over-range” maximum value of 100 ppm for better resolution of the measurement values than available using the intrinsic measurement range of 0 – 1000 ppm.



This is accomplished by selecting the User Expanded Range  icon (Figure 7-17 B) and setting the value to 100 ppm with the keypad, limiting the maximum range to 100 ppm.

If the actual process measurements values are generally confined to values below 10 ppm, then you might want to define a working range of 0 – 10 ppm to provide even more precision at the lower process concentration values. You can set the User High Range to 10 and the User Low Range will remain at “0”.

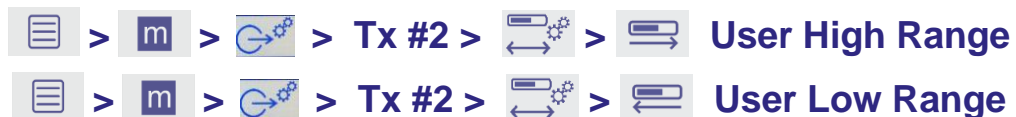

### 7.3.6 Auto-range ON /OFF Functionality Examples

The following two examples illustrate how the serial output and display behave with Auto-range OFF and with Auto-range ON for a transducer with an intrinsic measurement range of 0-1000ppm, the User High Range set at 10ppm and the User Expanded Range set at 100ppm.

#### Example 1 Auto-Range OFF

##### Initial Settings:

- User High Range set to 10 ppm, User Low Range set to 0 ppm, User Expanded Range set to 100 ppm.
- The serial output values will be scaled to the User High Range of 10 ppm.
- The display bar and output values will be scaled to the User High Range of 10 ppm.



<b>Measured Value ≤ 10 ppm</b>	<b>User Low (0 ppm)</b>	<b>User High (10 ppm)</b>	<b>Expanded (100 ppm)</b>
Serial Output	X	X	
Display Output	X	X	

**Any time the gas measurement value is at or above the User High Range of 10 ppm:**

- The serial output value will remain fixed at 10 ppm.
- The analyzer display will continue to show the measurement values up to the User Expanded Range maximum of 100 ppm.

<b>Measured Value ≥ 10 ppm</b>	<b>User Low (0 ppm)</b>	<b>User High (10 ppm)</b>	<b>Expanded (100 ppm)</b>
Serial Output		X	
Display Output	X		X

**Any time the gas measurement value is at or above 100 ppm:**

- The serial output value will remain fixed at 10 ppm.
- The analyzer display value will remain fixed at 100 ppm.

<b>Measured Value ≥ 100 ppm</b>	<b>User Low (0 ppm)</b>	<b>User High (10 ppm)</b>	<b>Expanded (100 ppm)</b>
Serial Output		X	
Display Output			X

*Note: If the user does not set an Expanded Range and sets a User High Range of 10 ppm, then for a gas measurement value above 10 ppm the Serial output will remain at 10 ppm and the analyzer display will continue to show the measurement values up to the maximum of the intrinsic range of the transducer ie 1000 ppm.*

**Example 2 Auto-Range ON**

**Initial Settings:**

- User High Range set to 10 ppm, User Low Range to 0 ppm, User Expanded Range set to 100 ppm.
- The serial output values will be scaled to the User High Range of 10 ppm.
- The display bar and output values will be scaled to the User High Range of 10 ppm.

<b>Measured Value ≤ 10 ppm</b>	<b>User Low (0 ppm)</b>	<b>User High (10 ppm)</b>	<b>Expanded (100 ppm)</b>
Serial Output	X	X	

Display Output	X	X
----------------	---	---

**Any time the gas measurement value is at or above the User High Range of 10 ppm:**

- The serial output value will automatically rescale to the User Expanded Range maximum of 100 ppm.
- The display bar graph value will automatically rescale to the User Expanded Range maximum of 100 ppm.

Measured Value ≥ 10 ppm	User Low (0 ppm)	User High (10 ppm)	Expanded (100 ppm)
Serial Output	X		X
Display Output	X		X

**Any time the gas measurement value is at or above 100 ppm:**

- The serial output value will remain fixed at 100 ppm.
- The analyzer display value will remain fixed at 100 ppm.

Measured Value ≥ 100 ppm	User Low (0 ppm)	User High (10 ppm)	Expanded (100 ppm)
Serial Output			X
Display Output			X



*Note: If the user does not set an Expanded Range and sets a User High Range of 10 ppm, then for a gas measurement value above 10 ppm the Serial output and the analyzer display will automatically rescale the measurement values up to the maximum of the intrinsic range of the transducer ie 1000 ppm.*

## 7.4 Configure the measurement mA Output

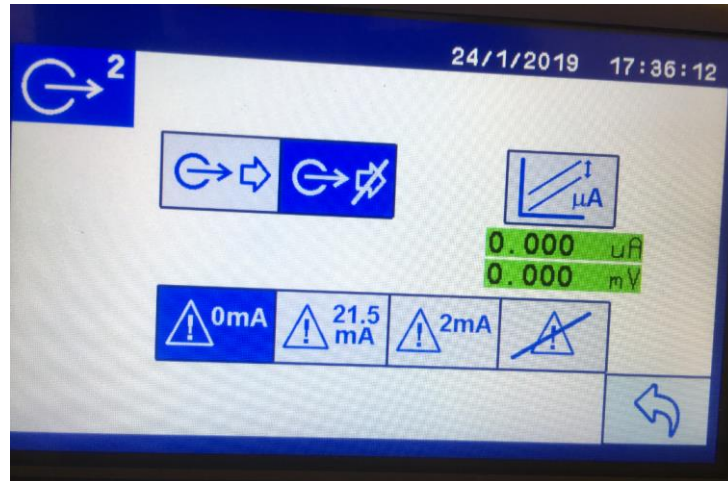





**Figure 7-19: mA output screen**





Each transducer is supplied with an associated 4-20mA output. On the mA output screen select either to “Follow”  or “Not Follow”  the concentration changes during calibration. If the “Not Follow”  is selected then the mA output signal will freeze at the last measured value until the calibration has finished.



You can make small adjustments to the mA output using the  icon (see 7.4).

A jam condition occurs when the incoming data has a Fatal Flag or when the Transducer has a Communications Fault that stops the data. By assigning a jam condition the user is able to distinguish between valid and non-valid readings.

Once the adjustments and flags are set, touch the  icon to save the mA output information or the  icon to quit the screen without saving.

**Table 7-8: Measurement mA Output icons**

Icon	Meaning	Function
	Follow	The mA output continues to follow the measured concentration during calibration.
	Not follow	The mA output freezes during calibration.
	mA output adjustment	Tweak the mA output with small incremental adjustment.
 	Jam condition Low	A jam condition occurs when the incoming data has a Fatal Flag or when the Transducer has a Communications Fault. The options for a Low Jam value is 0 or 2.0 mA.

Icon	Meaning	Function
	Jam condition High	A jam condition happens when the incoming data has a Fatal Flag or when the Transducer has a Communications Fault. The High Jam value is 21.5 mA.
	No Jam State	This disables the Jam State.
	Return	Touch this icon to accept the Range settings and return to the previous screen.

## 7.5 Select the displayed number of decimal places for the mA input

You can control the number of decimal places displayed for the mA input (i.e. the “External” analog input). The default number of decimal places displayed is six. This may be adjusted by the values entered into the upper and lower limits for the mA input. See Figure 7-20. The lower value has been entered as “4.0” and the upper value as “20.00”. The decimal places displayed will be the lesser of these two values ie 1 decimal place.

Note: You must touch the GREEN ENTER  key for this change to occur. If you touch the  key the entered values will be displayed but will default to 6 decimal places.

Note: To change the number of decimal places displayed, you have to enter a value with the required number of decimal places and save it by touching .

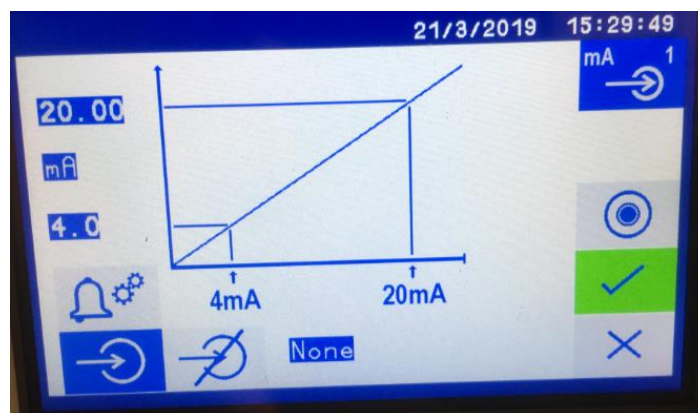
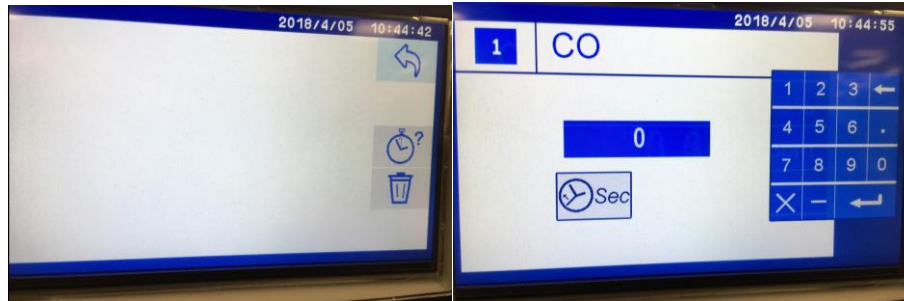

Figure 7-20: mA input screen

## 7.6 Configure the measurement record option





The measurement record option allows the operator to save time-stamped concentration readings in seconds, minutes and hours as a text file to the analyzer which can then be exported to a USB stick. It is possible to configure multiple record files if there are two or more transducers.



**Figure 7-21: Measurement Record (left) and Record Timing Setup (right) screens**

To store a result:

1. Touch the  clock icon to toggle through the time options until the required time page displays.
2. Type **1** on the numeric pad to select 1 second, 1 minute or 1 hour, depending on the time interval selected.
3. Touch the  icon to start the logging.
4. To stop the logging, set the time interval to zero by typing **0** on the numeric pad.

To view a result:

1. The log must be saved onto a memory stick before it can be viewed.
2. Insert a memory stick into the USB socket located at the bottom of the right side of the front panel.
3. Use the following sequence to navigate to the Diagnostics branch page to access the USB icon and touch to save the files to the USB stick:











4. Several system files including the measurement logs will be written onto the memory stick. Column 1 is the ppm measured value; column 2 is the date; column 3 is the time.

50	27/7/2016	09:34:09
50	27/7/2016	09:44:09
50	27/7/2016	09:54:09
50	27/7/2016	10:04:10

50	27/7/2016	10:14:10
50	27/7/2016	10:24:10
51	27/7/2016	10:34:10
51	27/7/2016	10:44:10
51	27/7/2016	10:54:10
51	27/7/2016	11:04:10

*Note: To stop the logging you must set the time interval to zero. Type 0 on the numeric pad and press  key to accept the value.*

**Table 7-9: Measurement Record icons**

Icon	Function
	Set the data recording timing. Once set the data is recorded until the user stops the recording from this page.
	Data Recording rate in Seconds. To record data in Minutes touch the icon again to show the minutes icon, to record in hours touch again to display the Hours icon.
	Access the Delete Data Icon.
	Delete the recorded data from the analyzers.
	Return to the Alarm settings Home screen.
	Delete the last digit typed in.
	Accept the value entered in the keypad. Typing in "0" on the keypad will stop the data recording if the Return key is pressed.
	Cancel the value entered in the keypad.

If you use your finger or Stylus and click on the center of the screen, a Data Recording Plot will show up, presenting the last 10 hours of data that was recorded. See Figure 7-22.



Figure 7-22: Showing data recording plot – Touch center of screen (left) and Data Recording Plot screen (right)

## 7.7 Configuring the Measurement data filter and gas reporting units

### 7.7.1 Setting the Measurement data filter

The transducer determines which filter types are available. Trial and error testing will be needed to determine which filter type is best for the application as well as how many points are needed in the filter, as there are trade-offs with response time and signal improvement. The default mode applies no filtering.

There are two kinds of filters available: Moving Average or Finite Impulse Response (FIR) and Exponential or Infinite Impulse Response (IIR). The filters shown on the left column of Figure 7-23 are Moving Average, those in the right column are Exponential.

For each of these filter types, the smoothing icon shown top to bottom represents the smoothing function that is faster but less smooth to slower but smoother at the bottom.

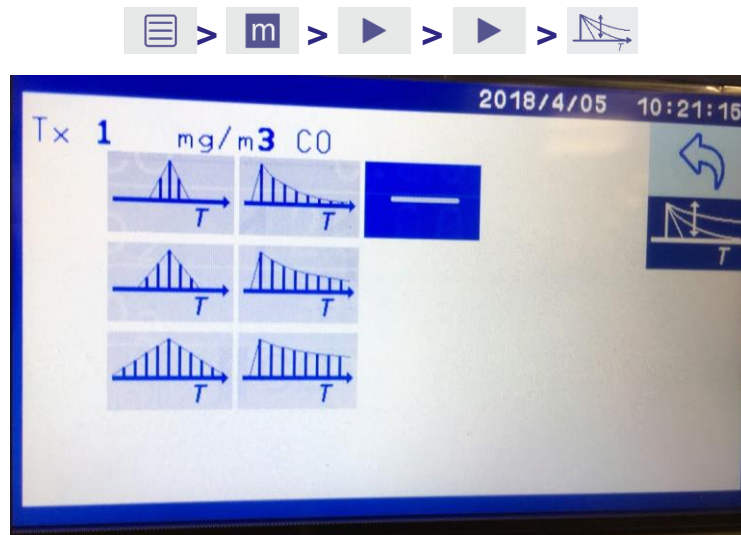

Figure 7-23: Data Filter screen showing two filter types with short, medium, long time averages (no filter is selected at this time).

With a Moving Average filter, the actual output is the average of the latest value and a fixed number of previous input values, with the previous inputs weighted less so they contribute less to the output.

With an Exponential filter the output is an average of the latest value and one or more previous output values, with previous output values being weighed less. It is called “infinite” because every new value always makes some contribution to the new output and diminishing contributions to all subsequent output values.

In either case, the more points used in the average or the higher the weighting is from the older values, the smoother the response will be, but the consequence is that the response to changes in the incoming values will be slower.

## 7.8 Transducer Diagnostics

This section provides access to the diagnostics for installed transducers that support diagnostics at this time. We are working on allowing user access to diagnostics for all our transducers and these new features will roll out in successive firmware updates. Figure 7-24 shows an example of the diagnostics for a GFX transducer.

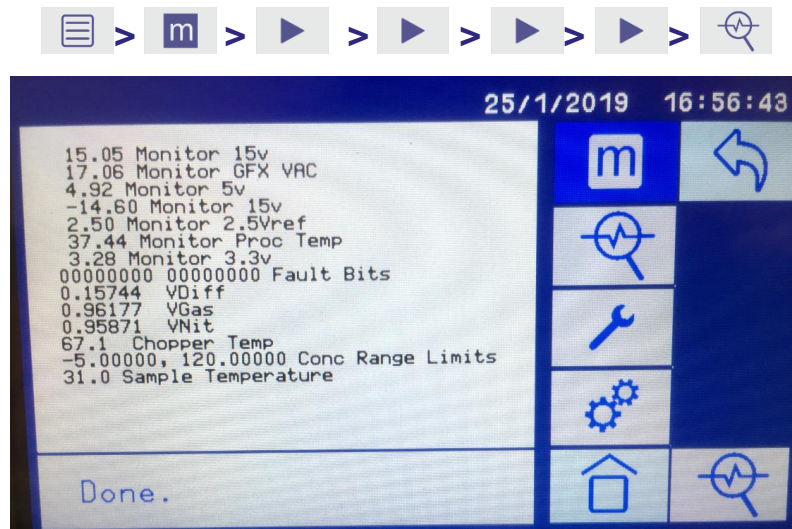

**Figure 7-24: GFX transducer diagnostic screen**

The diagnostic values are meant for interpretation by service personnel and be used to report the values back to a Servomex service person for troubleshooting the problem.



## 8 Diagnostics branch screen

### 8.1 Diagnostic branch icons





Touch the Diagnostics icon to see the available diagnostic functions to the right.

The screen views for each of the three pages available within the Diagnostic branch are shown in Figure 8-1, Figure 8-2, and Figure 8-4 (Relay Diagnostics).

The Relay Diagnostics page allows testing of the assigned the relays. The actual state of the relay is assigned in the Setting  (see Section 10 ).

*Note: Page 1 displays first.*

*To go to the subsequent pages, press the  icon.*

*To return to the previous page, press the  icon.*

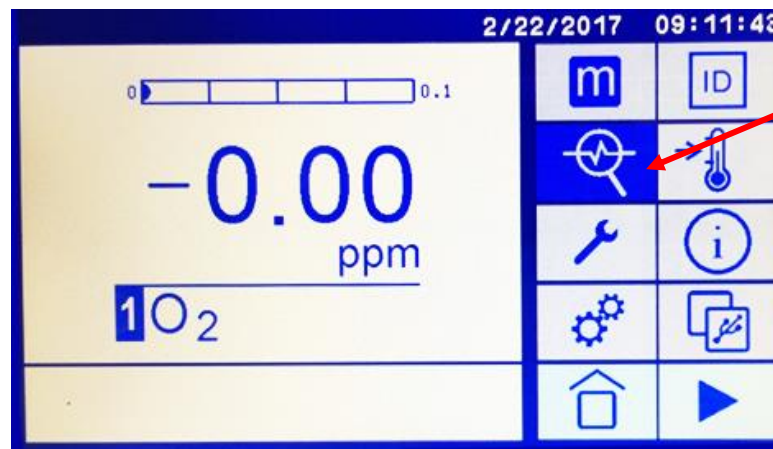

Figure 8-1: Diagnostics screen – page 1

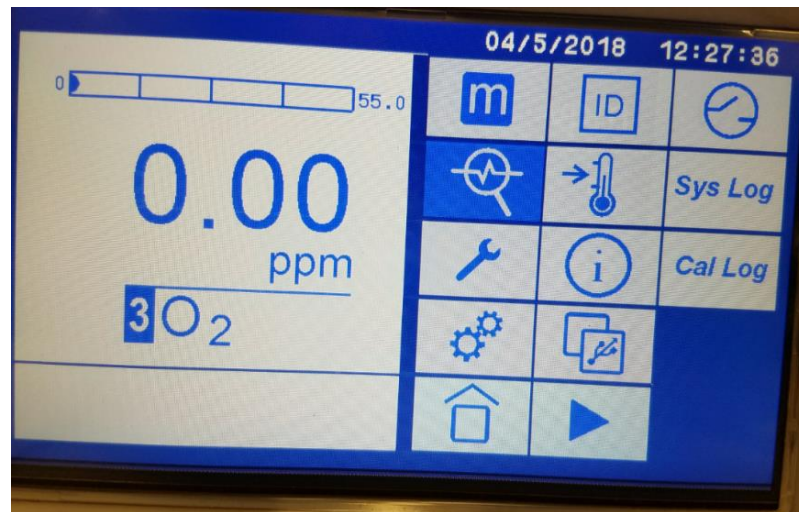









Figure 8-2: Diagnostics screen – page 2

Table 8-1: Diagnostics icons

Icon	Meaning	Function
	Software revision	Display the software revision number.
	Analyzer Electronics Temperature	Display the temperature of the internal chassis electronics of the analyzer.
	Analyzer serial number	Display the serial number of the analyzer.
	Save system files to USB	Save the system files to a USB memory device. Unit will beep if you do not have a USB device installed.
	Relay test menu	To view and test the relays that were purchased. When background is blue then the relay is closed.
	System Log	Display up to 100 pages of logged system activities with most current date first. Use the arrow keys to navigate through the pages.
	Calibration Log	Display up to 100 pages of logged calibration activities with the most current date first. Use the arrow keys to navigate through the pages.

## 8.2 Saving the system log files

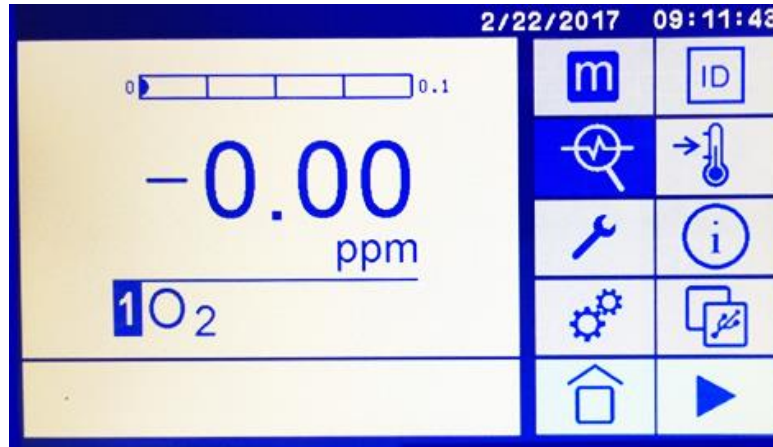



Figure 8-3: Log file save screen



A USB thumb drive must be installed into the slot located on the bottom right side of the front panel prior to accessing the Log Save icon . The text files will be written to the USB drive when this icon is touched. The analyser will beep if there is no USB in the port and the system will stop.

## 8.3 Testing the Relays

The relays are numbered to support quick testing and can be individually tested to help debug an installation.



Figure 8-4: Relay diagnostics screen

To test the function, press the relay icon to open and close it. If a relay is closed, its icon background is dark blue ; if a relay is open, its icon has a white background  (see Figure 8-4). When the Relay Diagnostics page is exited, the relays will be reset back to the state they were in prior to entering the Relay Diagnostics page.

For example, if relay #8 alarm state was triggered then relay #8 would show closed  prior to entering the Diagnostics menu. When exiting the Relay Diagnostics page, relay #8 will be set back to the closed position even if the relay had been opened on the diagnostics page.

If Auto-Cal function is purchased the last three relays on each transducer option card are pre-assigned and cannot be changed by the user (see Figure 8-5). The relay number icons are now replaced by new icons that represent each of the Auto-Cal Zero, Span and Measure functions.



Relay #6 is pre-set as the Zero or Low Span function , Relay #7 is pre-set as the High Span function , and Relay #8 is pre-set as the Sample / Measurement function  for Transducer #1. Relays #14, #15, #16 are pre-set in the same manner for Transducer #2.



Figure 8-5: Relay diagnostics screen with Auto-Cal option

## 8.4 Displaying the System or Calibration Log

The System Log or the Calibration Log can be easily accessed and displayed showing the most recent activity first on the first page. Activities on the earlier dates can be accessed via the up and down arrows.

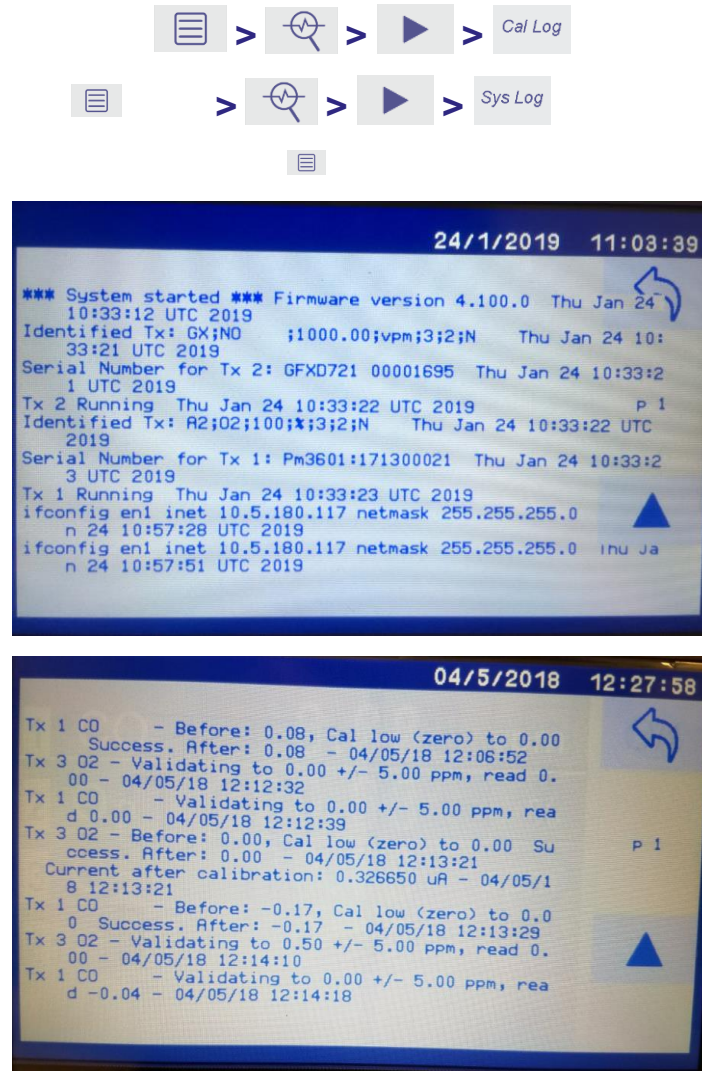

Figure 8-6: Examples of System Log and Calibration Log Reports

## 9 Maintenance branch screen



Touch the Maintenance icon to see the available icon choices to the right. The Maintenance branch menu has one page, shown in Figure 9-1.

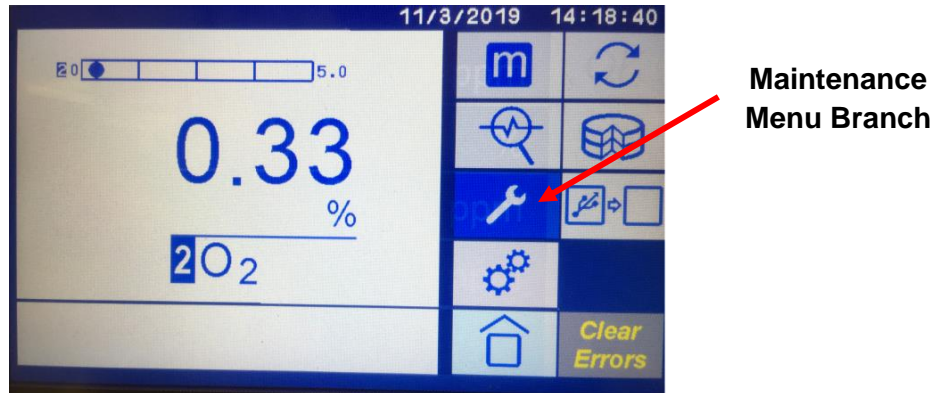





Figure 9-1: Maintenance screen

Table 9-1: Maintenance branch icons

Icon	Meaning	Function
	Update firmware	To update the firmware in the field when needed. Insert the USB thumb drive into the slot in the lower right corner of the front panel, then touch the icon to update the firmware.
	Disk Management	To copy data to a USB memory device, view capacity and delete the log files.
	Read config files from USB memory device	To upload configuration files from a USB memory device. Insert the USB thumb drive holding the configuration files into the slot in the lower right corner of the front panel, then touch the icon to upload the new configuration files.
	Clear errors	To clear any error warnings such as Failed Calibration.

## 9.1 Disk Management



This screen displays the amount of memory used, how much space is still available in kilobytes and the percent of total disk space that is used. The displayed icons allow selective freeing up of disk space and to copy the data from the disk to a USB memory device. (see Figure 9-2)

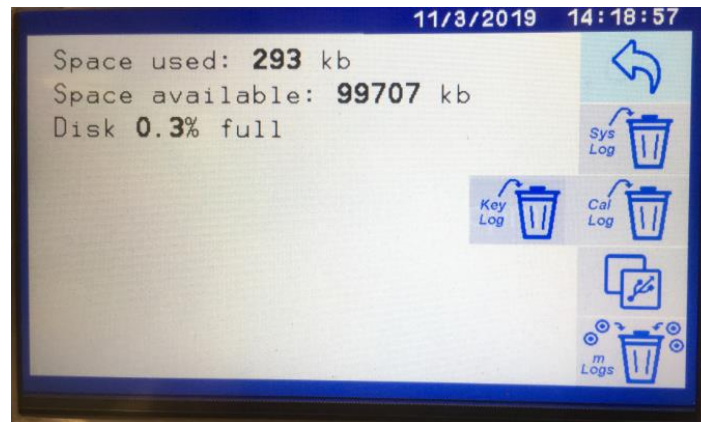







Figure 9-2: Disk Management screen

Table 9-2: Disk Management Icons

Icon	Meaning	Function
	Delete System Logs	To delete all of the System Logs from the Analyzer Memory.
	Delete Keystroke Logs	To delete all of the Keystroke Logs from the Analyzer Memory.
	Delete Calibration Logs	To delete all of the Calibration Logs from the Analyzer Memory.
	Save Data to USB	To copy the recorded data from the Analyzer Memory to a USB stick.
	Delete <b>Data Recording</b> Logs	To delete all of the Data Recording Logs from the Analyzer Memory.

## 10 Settings branch screen

Touch the Settings menu icon to see the available settings functions to the right.

The screen views for each of the three pages available within the Settings branch are shown in Figure 10-1, Figure 10-2, and Figure 10-3.

*Note: Page 1 displays first.*

*To go to the subsequent pages, press the  icon.*

*To go back to the previous page, press the  icon.*



Settings  
Menu  
Branch  
active

Figure 10-1: Settings main screen 1



Settings  
Menu:  
Next  
List  
active

Figure 10-2: Settings main screen 2



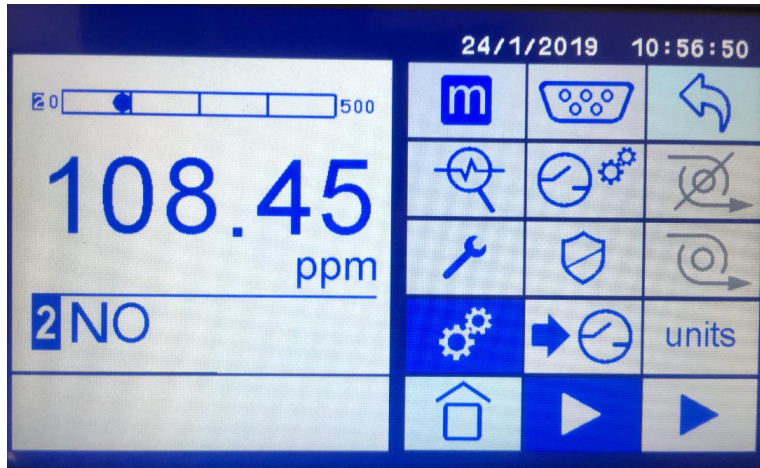

Figure 10-3: Settings main screen 3

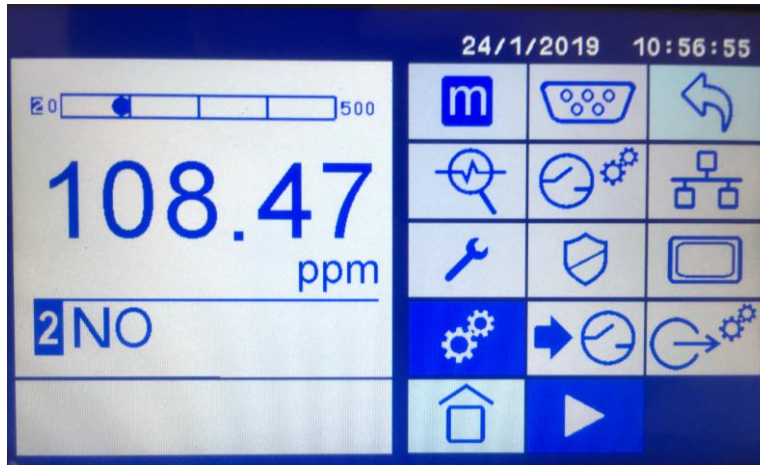















Figure 10-4: Settings main screen 4

Table 10-1: Settings Branch icons

Icon	Meaning	Function
	Serial port set up	Set up serial communications parameters.
	Relay set up	Set up the relays.
	Password set up	Access the password security icons for Master and Operator levels.

	Manual relay over-ride	Manually set the relay to a state (i.e. Off or On); when selected this will be the permanent state until the relay function is reset.
	Analyzer Date	Set the date for the analyzer system.
	Analyzer Time	Set the time for the analyzer system.
	Digital and Analog Inputs	Set up for any of the analog and/or digital inputs if purchased.
	Pump Off	Option is not available for MultiExact 4200 therefore the icons are greyed out.
	Pump On	Option is not available for MultiExact 4200 therefore the icons are greyed out.
	Data Reporting Units Selection	Change the units from ppm to mg/Nm <sup>3</sup> or the reverse.
	Modbus TCP/IP	Used to activate and select mode of the Modbus TCP/IP communications (over ethernet port)
	Screen Functions	Assign ICONS to Favorites shortcut page, switch from Single to Multiple gases displayed, adjust brightness, adjust screen “home” timer.
	Analog Output Range Settings	Used to reset the display range bar and the mA output to a user defined maximum limit (User Extended Range) and to define a lower measurement range (User High Range and User Low Range limits) on each of the transducers see Section 7.3.5 for details.
	Analog Output Settings	Used to configure the 4-20mA or the 0 – 10V output (see Section Configure the measurement mA Output7.4 for details).

## 10.1 Serial outputs overview



This section is only an overview of the screens associated with the serial output communication configurations while the details can be found in Appendix B. The serial output option operates by transmitting a data frame to the RS232 (or RS 485) output port at a user defined interval. The format of the data frame is a semi colon separated list of process variables terminated by <carriage return><line feed>. The data frame is time and date stamped.

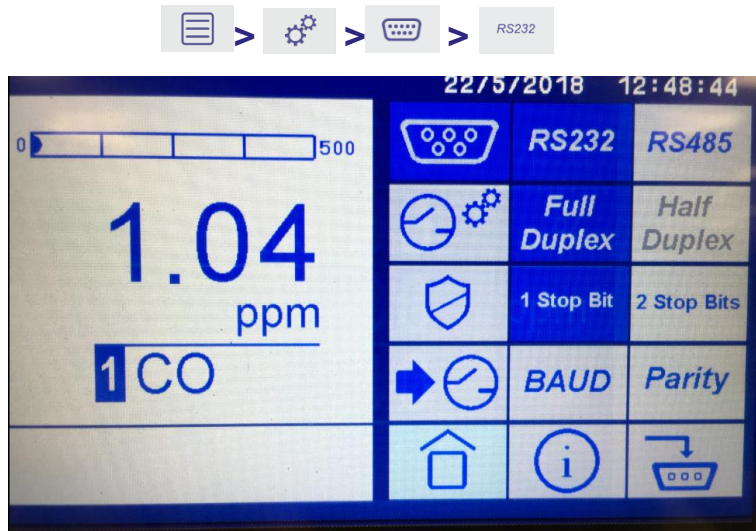

Figure 10-5. RS232 functions view.

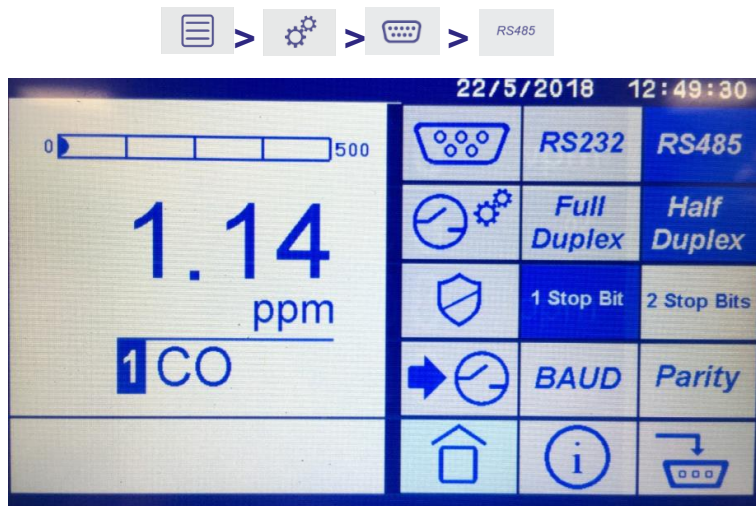

Figure 10-6. RS485 functions view.

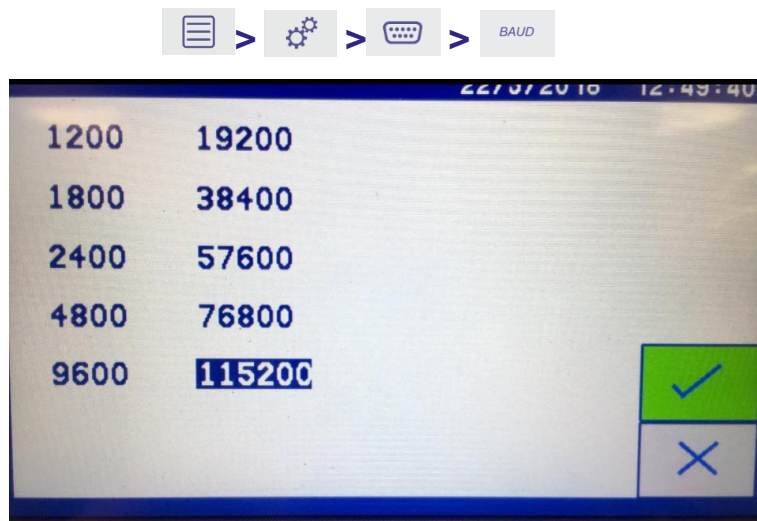

Figure 10-7. Baud Rate selection panel.

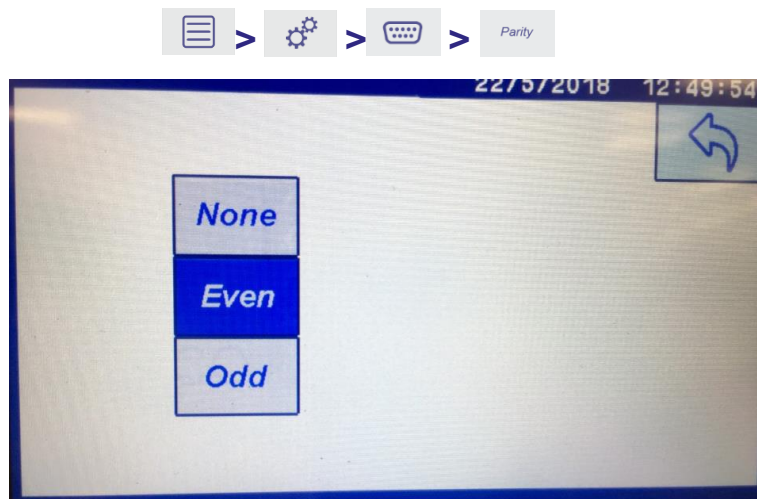

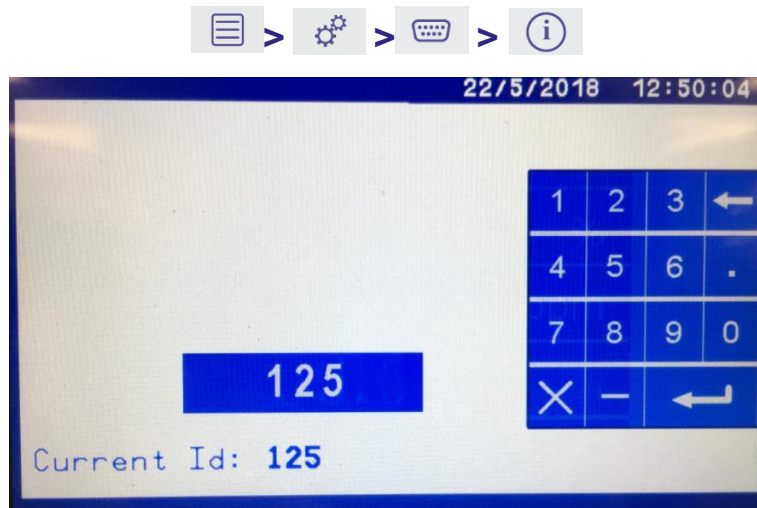

Figure 10-8. Parity selection panel.

Note: To return to the previous page, press the  icon.

To accept the changes, press the  icon.

To cancel any changes, press the  icon.

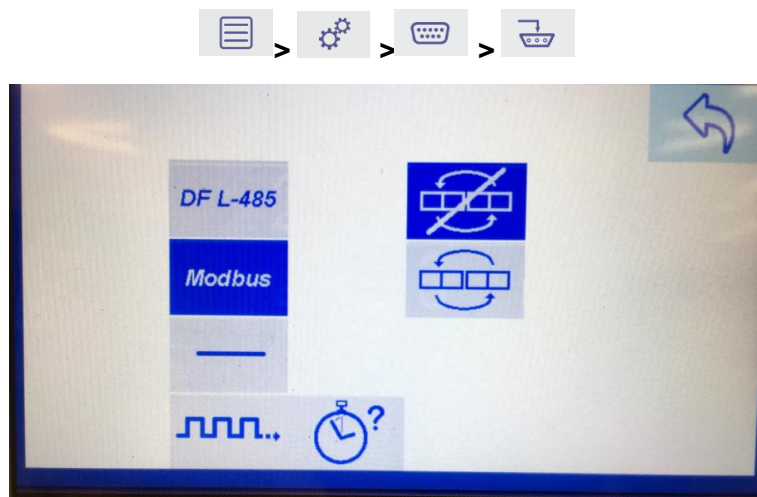

**Figure 10-9. Output ID setting screen**

*Note:* To delete the last digit typed in, press the  icon.

















To accept the changes, press the  icon.

To cancel any changes, press the  icon.



**Figure 10-10. Modbus 485 settings screen.**

**Table 10-2: Main Serial mA Analog Output icons**

<b>Icon</b>	<b>Meaning</b>	<b>Function</b>
	RS232 communications	To select RS232.
	RS485 communications	To select RS485.
	Full Duplex	To select full duplex.
	Half Duplex	To select half duplex.
	1 stop bit	To set 1 stop bit.
	2 stop bits	To set 2 stop bits.
	Baud rate	To set the baud rate.
	Parity	To set the parity.
	RS485 function	To assign RS485 functions. Functions on this section screen are shown in Figure B-3 and listed below:
	RS485 function: DF communications	To assign RS485 function to legacy Delta F (DF-485) communications.
	RS485 function: Modbus	To assign RS485 function to Modbus (Appendix C).
	RS485 function: None	No RS485 function.
	RS485 function: periodic stream	To assign a periodic stream of measurement results of all transducers.
	RS485 function: output frequency setup	To set the intervals for the output frequency (in seconds) via a numerical entry screen.
	RS485 – Modbus: Word swapping on	To switch on Modbus word swapping.
	RS485 – Modbus:	To switch off Modbus word swapping.

Icon	Meaning	Function
	Word swapping off	

## 10.2 Assigning relay activity functions



The function of the relay can be assigned using the relay configuration settings  menu and selecting the appropriate relay. Each relay is set up to respond to any function or combination of functions including Faults, Service in Progress, Any type of Alarm. Once an activity has been assigned to the relay, the icon will take on a symbol reflecting the new assigned function (see Figure 10-11).

*Note: If Auto-Cal is purchased then Relays at positions #6, #7 and #8 on each of the transducers will be pre-assigned to output as Zero, Span and Sample / Measurement modes. They cannot be reassigned (see Figure 10-11).*



**Figure 10-11: Available relays on the system with Auto-Cal pre-assigned relays.**

If there are more relays available, then use the Next  icon to access the next page (see Figure 10-11).

*Note: There can be up to eight relays per transducer giving a maximum of 32 if four transducers are purchased or extra option boards added.*

### 10.2.1 Assigning Alarms, Functions and Activities to the relays

Use the Activity Assignment Menu (Figure 10-12) to assign a function to a specific relay by touching the functions icon and activating it. Each relay can be assigned to one or more of the transducers purchased, which will be listed on the screen. Any number of links may be made between any function to any relay card present within the analyzer.

Note: To go to the other assignment pages, press the  icon.

To accept the changes, press the  icon.

To cancel any changes, press the  icon.

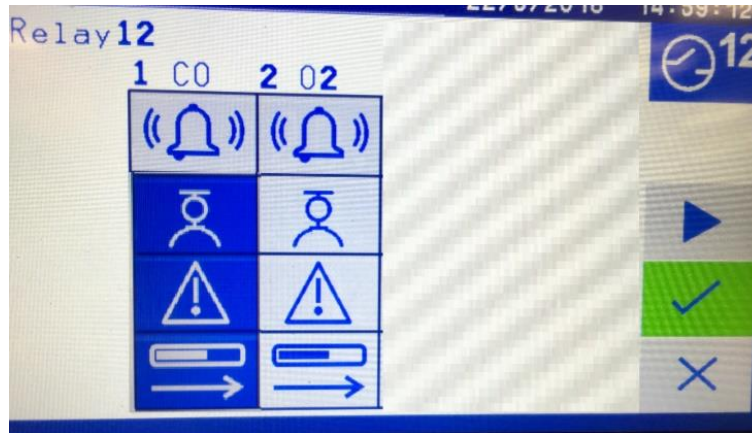

**Figure 10-12: Activity Assignment Menu for Relay #12 in an analyzer with two transducers (CO and O<sub>2</sub>).**

Multiple activities can be assigned to one relay. In Figure 10-12 the Calibration, Fault and Out of Range functions for the CO transducer are all active (so the icons show a dark blue background) and are assigned to Relay #12.

Those activities can also be linked to different transducers present in the analyzer. In Figure 10-12 Relay #12 can be assigned alarms for Transducer #1 (CO) and / or Transducer #2 (O<sub>2</sub>). To assign an alarm to Transducer #2 (in this case it is O<sub>2</sub>):



- touch the alarm icon  located below the O<sub>2</sub> symbol as shown in Figure 10-12
- touch the icon for Alarm #1  as shown in Figure 10-13 to set the alarm











Figure 10-13: Alarm assignment screen for O<sub>2</sub> (Relay #12)

Table 10-3: Relay Activity Function Assignment Icons

Icon	Meaning	Function
	Alarm	Relay is set as an alarm on a specific transducer.
	Service / Calibration in progress	Relay is set to output “Service in Progress” signal triggered when a Calibration / Validation is in progress on a specific transducer. Allows detection of this state remotely.
	Fault Alarm	Relay is set to send a signal out if the transducer incurs a Fault such as over-range of intrinsic range, communications failure, etc..
	Range Change	Relay is set to output a “Changed to Expanded Range” signal on a specific transducer when the concentration is greater than the User High Span range.



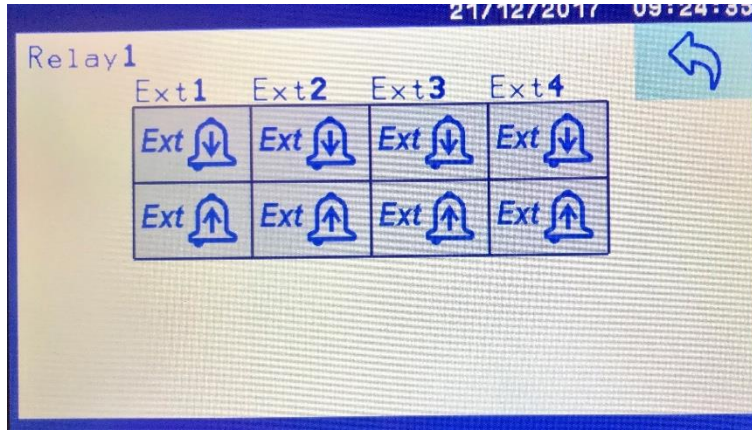

### 10.2.2 Assigning Alarms for External 4-20mA Inputs to the relays

There is one external 4-20mA Input per option board. In Figure 10-14 Relay #1  is assigned to the analog Input High and/or Low alarm. Use the Analog Input Section 10.7.1 to assign the actual limit values for the relays to alarm at.









**Figure 10-14: Relay Low / Hi alarm fault assignment screen for external mA inputs**

- Touch the  icon to set the Low Limit alarm (Figure 10-14).
- Touch the  icon to set the Hi Limit alarm (Figure 10-14).
- Touch the  icon to return to the relay assignment page (Figure 10-14).
- Touch the  icon (see Figure 10-12) to save the relay information.

### 10.3 Assigning Password Protection

There are two levels of operation under password protection: Master or Operator. The Master Password allows access to all MASTER and OPERATOR level functions while the Operator Password allows access to only the OPERATOR level functions.

Touch the Password Assignment  icon to see the Operator , Master  and Keystroke Record  icons in the column furthest right (see Figure 10-15).

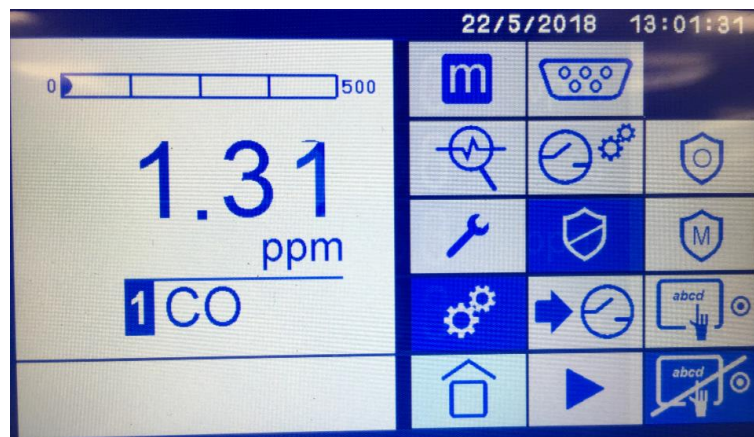



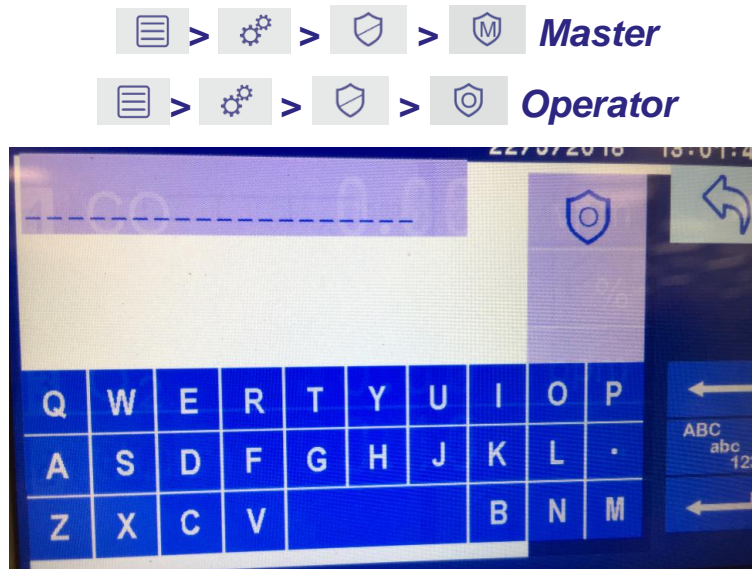

**Figure 10-15: Settings Password Protection with Record Keystroke screen**

To set a password touch the icon for the required password level then enter the new password using the keypad (see Figure 10-16).



**Figure 10-16: Settings Password Protection screen for Master or Operator**

**Table 10-4: Password Protection Assignment Icons**

Icon	Meaning	Function
	Master Password	Set the analyzer master level password.
	Operator Password	Set the analyzer operator level password.
	Keystroke Recording On	Turn keystroke recording On to capture all keystrokes used to the System Log file.
	Keystroke Recording Off	Turn keystroke recording Off.

Once a master and/or operator password are set all protected icons and operations will prompt for a password. If no passwords are set, then the protected icons and operations will not prompt to have a password entered.

To reset or deactivate the OPERATOR password enter the OPERATOR password as a blank / empty field. You will need the Master password to re-enter either the MASTER or OPERATOR password. If you have forgotten the MASTER password a remote recovery service password can be provided with a call to your local customer service center.

**Table 10-5: Master and Operator password protection operations**

<b>Function</b>	<b>Level</b>
ADAPTIVE FILTERING ON/OFF	MASTER
CALENDAR	MASTER
CLEAR ERRORS	MASTER
CLOCK	MASTER
GSF ENTRY OR SELECTION	MASTER
INSTALL CONFIG FROM USB	MASTER
KEYSTROKE RECORDING	MASTER
MILLIAMP OUTPUT	MASTER
PASSWORDS	MASTER
ANALOG OUTPUT RANGE SETTING	MASTER
RECORD CONTROLS	MASTER
SCHEDULED EVENT SETUP	MASTER
SENSOR ON/OFF	MASTER
RELAY ASSIGNMENT	MASTER
SUPPRESS NEGATIVE	MASTER
TEST RELAYS	MASTER
TRANSDUCER PRESSURE COMPENSATION	MASTER
XINT INPUT	MASTER
FIRMWARE UPGRADE	MASTER
ADJUST FILTERING	MASTER
MILLIAMP INPUT	MASTER
DIGITAL INPUT	MASTER
<hr/> <hr/>	
ALARM SELECTION FOR EDIT	OPERATOR
CALIBRATION	OPERATOR
LOCK TO SINGLE DISPLAY	OPERATOR
MANUALLY SWITCHING RELAYS	OPERATOR
SAVE DATA TO USB	OPERATOR
ANALOG-IN ALARM SELECTION FOR EDIT	OPERATOR
ADJUST SERIAL PORT SETTINGS	OPERATOR

*Note: Some functions may not be available depending upon the variant of the analyzer that was purchased.*

## 10.4 Manual relay over-ride setting

This function allows the user to manually set the relay to one of three states: normal operation, Over-ride/Forced OFF or Over-ride/Forced ON. When selected this will be the permanent state until the relay function is reset. In Figure 10-17, Relays #8 and #16 are in normal operation ON and Relay #7 is in Manual over-ride operation ON.





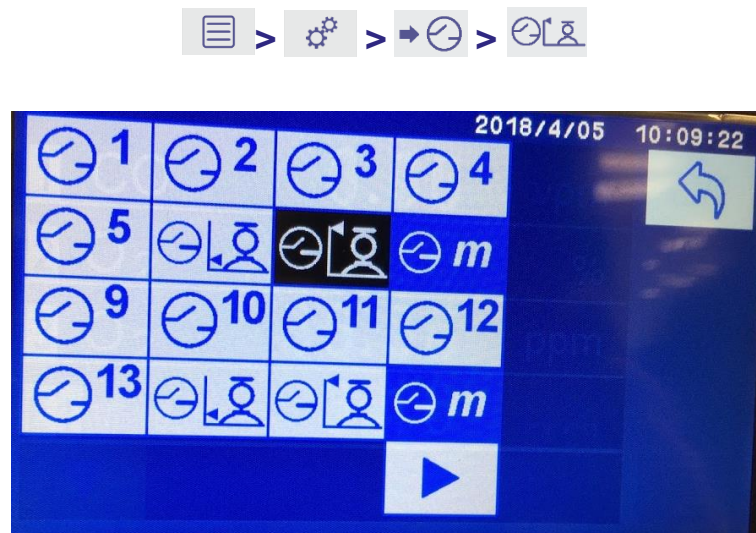

**Caution: when you leave this menu page, the relays do NOT revert back to the original settings.**





**Figure 10-17: Manual relay over-ride of Relay #7 (with Auto-Cal ON)**

The function will cycle through three states each time the relay icon is touched:







- Normal Operation (originally assigned ON  or OFF )
- Over-ride / Forced ON (now assigned ON )
- Over-ride / Forced OFF (now assigned OFF )

Relays power up in their designated state: Normal (ON  or OFF ). By repeatedly touching the relay icon the sequence will cycle continuously through each state in turn - Normal Operation, Forced ON, and Forced OFF. The relay will stay in the state it was cycled to. If this is not the Normal state then the over-ride (Forced) state will now be

the new permanent relay state. The state designations are shown by the icon color change. See the table below for details on the icons and states.

**Table 10-6: Manual Over-ride Icons**

Icon	Meaning	Function
	Normal Operation – relay is Off	Indicates the assigned condition of the relay is off. If a relay is left in this state when exiting the screen the Normal operation will now be that the relay is off – note icon color scheme is light grey background with dark blue text.
	Normal Operation – relay is On	Indicates the assigned condition of the relay is on. If a relay is left in this state when exiting the screen the Normal operation will now be that the relay is on – note icon color scheme is dark blue background with light gray text.
	Forced Off Over-ride Operation – relay is Off	Indicates a forced over-ride condition now exists that turns the relay off. If a relay is left in this state when exiting the screen the Normal operation will now be that the relay is off – note icon color scheme is light gray background with dark gray text.
	Forced On Over-ride Operation – relay is On	Indicates a forced over-ride condition now exists that turns the relay on. If a relay is left in this state when exiting the screen the Normal operation will now be that the relay is off – note icon color scheme is black background with light gray text.

*Note: There are three general functions to keep in mind that are available for relay settings and diagnostic testing that are accessed by the icon sequences below:*



This sequence is used to set and assign tasks / states to the relays described above in Section 10.2.



This sequence will over-ride the original state by forcing the relay to be On or Off. The condition is permanent until the relay is switched back to Normal Operation above in Section 10.4. When you exit the Manual Over-ride menu, any changes will be made permanent.





This sequence allows for diagnosis and testing of the relays, located in the Diagnostics Section 8. When you exit the Diagnostics menu, there are no changes made to the relays.

## 10.5 Setting the analyzer date





**Figure 10-18: Set the analyzer date screen**

1. Touch the first set of up or down arrows on the left-hand side to select how the date will be displayed (DD/MM/YY or MM/DD/YY or YY/DD/MM).
2. To set the date (Figure 10-18 shows the DD/MM/YY format):
  - a. Touch the second set of up or down arrows from the left-hand side to select the day (from 1 to 31).
  - b. Touch the third set of up or down arrows from the left-hand side to select the month (where 1 is January, and 12 is December).
  - c. Touch last set of up or down arrows from the right-hand side to select the year.
3. Touch the  icon to accept the value or the  icon to leave the screen without updating the value.

## 10.6 Setting the analyzer time



**Figure 10-19: Set the analyzer Time Screen**

1. Time is shown as HH:MM:SS (hours : minutes : seconds) and displays in 24 hour format.
2. Touch the left-hand up or down arrows to increase or decrease the hours (from 00 to 23).
3. Touch the middle up or down arrows to increase or decrease the minutes (from 00 to 59).
4. Touch the right-hand up or down arrows to increase or decrease the seconds (from 00 to 59).
5. Touch the  icon to accept the value or the  icon to leave the screen without updating the value.

## 10.7 Setting the Inputs

- There are two types of Inputs available, the mA Analog Input and the Digital Input, See Figure 10-20, (A) for mA Analog Input and (B) for Digital Input.





Figure 10-20: Settings sub-screen for mA Analog (A) and Digital (B) Inputs

### 10.7.1 Configuring the mA Analog Inputs

There is one optional mA Analog Input for each option board with a total of up to four in a fully-configured analyzer. Figure 10-21 shows three mA inputs have been purchased and their icons are shown in blue. The fourth mA input was not purchased and its icon is greyed out.



Figure 10-21: Active mA Analog Inputs that are purchased appear as blue pictures / text

The mA Analog Input is configured by touching areas on a graphic display. Figure 10-22 shows an example of the mA Analog Input #2 set up for an external Temperature Sensor

located in a plant emissions Stack or Chimney. The temperature input range is mapped to the 4-20mA from 0°C up to 200°C. The input signal will be displayed as one of the Analyzer measurement channels named “Stack” with the units or “T(C)”.

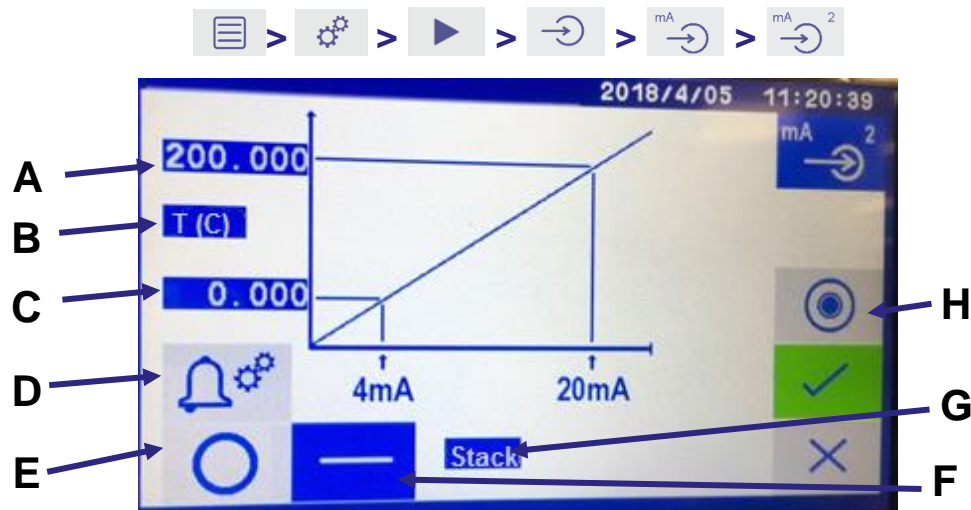

Figure 10-22: Screen for entering the mA analog input #2 example.

- |          |   |          |   |
|----------|---|----------|---|
| <b>A</b> | <b>Maximum range of analog input</b>        | <b>E</b> | <b>Turn On analog input</b>             |
| <b>B</b> | <b>Units or Description of analog input</b> | <b>F</b> | <b>Turn Off analog input (active)</b>   |
| <b>C</b> | <b>Minimum range of analog input</b>        | <b>G</b> | <b>Text Description of analog input</b> |
| <b>D</b> | <b>Set and alarm for the analog input</b>   | <b>H</b> | <b>Record analog signal</b>             |

Alarms can be assigned to the mA Input, in the same way as the standard transducer gas measurements. Figure 10-23 shows the mA Analog Input #2 with a High alarm threshold value set to “21.5” (Figure 10-23 B) however the function is currently disabled (Figure 10-23 D).



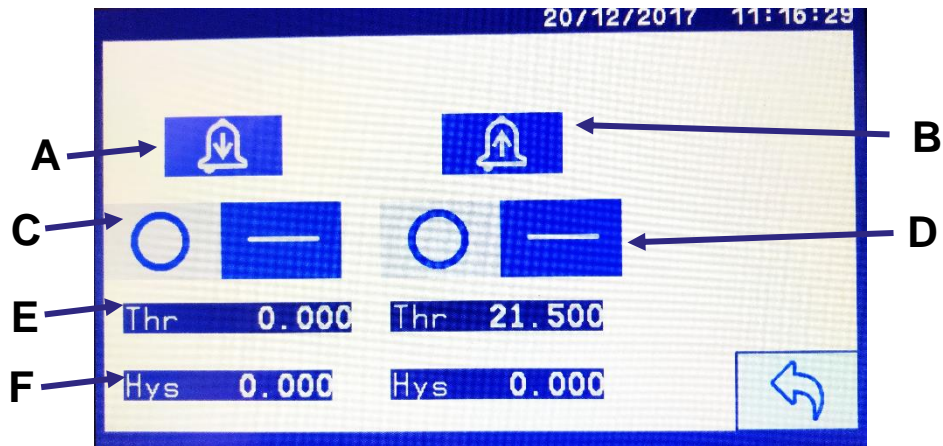

Figure 10-23: Settings Communications-Analog Input Alarm setting screen

- |          |                            |          |                                   |
|----------|----------------------------|----------|-----------------------------------|
| <b>A</b> | <i>Low alarm (active)</i>  | <b>D</b> | <i>Turn alarm Off (active)</i>    |
| <b>B</b> | <i>High alarm (active)</i> | <b>E</b> | <i>Alarm threshold set point</i>  |
| <b>C</b> | <i>Turn alarm On</i>       | <b>F</b> | <i>Alarm hysteresis set point</i> |

Table 10-7: mA Analog Input Icons

Icon	Meaning	Function
	Analog Inputs screen	Select an analog input to set up.
	Analog Input #2 set up	Set up a specific analog input, in this case #2.
	Record	Records the analog input measurement which can then be down loaded with a USB stick.
	High Alarm	Analog Input is set to High Alarm – value and threshold are set on the page.
	Low Alarm	Analog Input is set to Low Alarm – value and threshold are set on the page.
	Function is OFF	Analog Input is turned off.
	Function is ON	Analog Input is turned on.
	Threshold value	Input the threshold value that will trigger the Alarm.

Icon	Meaning	Function
	Hysteresis value	Input the hysteresis value at which the Alarm will reset.

## 10.7.2 Digital Input Settings

There are two Digital Inputs for each option board for a total of up to 8 for a fully-configured analyzer. The Digital Input can be used to control the calibration of a transducer or declare the state of an Analog Input.

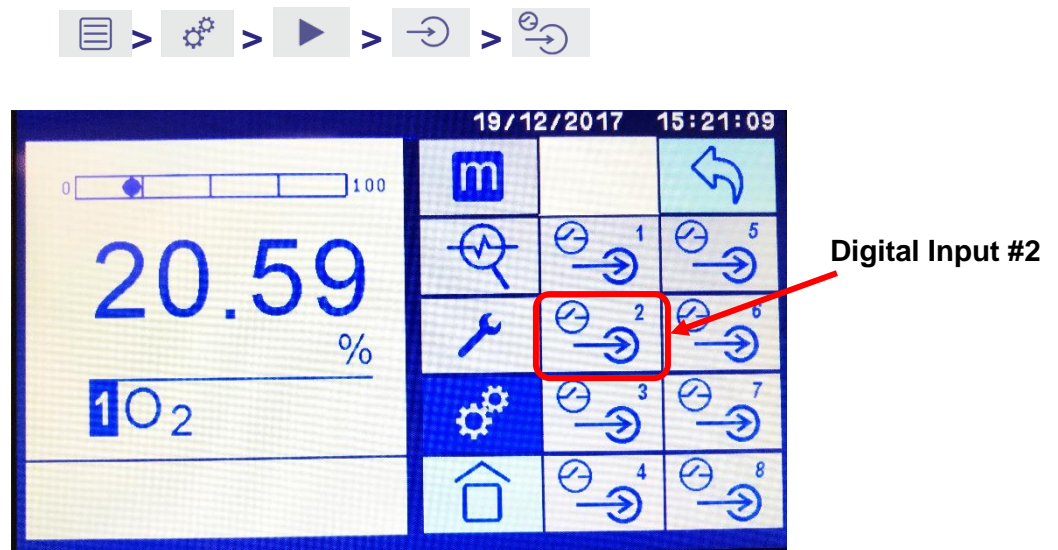

**Figure 10-24: Digital Inputs screen for setting up the digital inputs - total of 8 shown in this example)**

Figure 10-25 A shows the location of the Calibration operational icons and the Analog inputs shown in Figure 10-25 B.



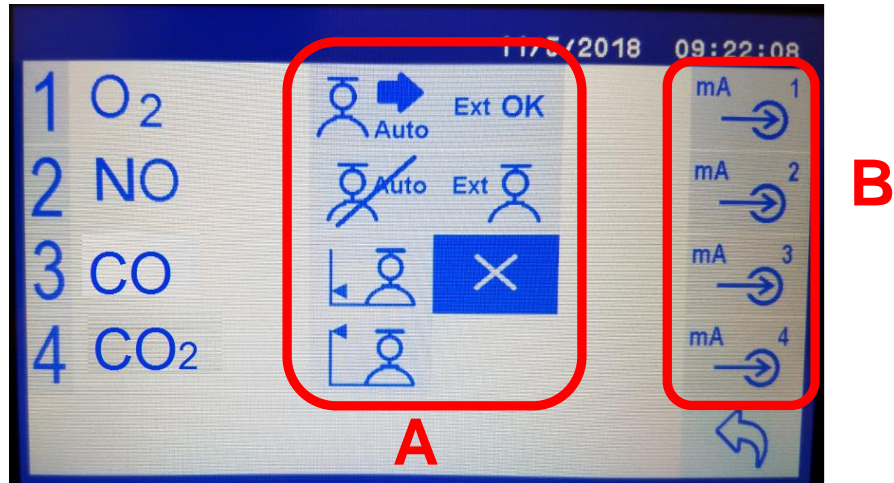







**Figure 10-25: Digital Inputs screen for Digital Input #2 showing the assignments for (A) Calibration control operational icons and (B) Analog input that can be controlled.**

A Digital Input operation is essentially a binary ON / OFF state that detects the contact closure between the labeled pins on the back-panel connectors. The Digital Input can only be assigned one action.

To configure a Digital Input operation the user must select both the operation and the target device.



Each Digital Input can be assigned as OFF or one of six possible operations. The available operations are shown in the box labelled A in Figure 10-25. From top to bottom, left to right for the transducer:

1. Start Auto-Cal  for the designated transducer  
*Note: It is important know that if more than one Auto-Cal sequence is assigned to a transducer, the Digital trigger will only launch the first sequence.*
2. Stop and disable Auto-Cal 
3. Initiate zero gas calibration 
4. Initiate span gas calibration 
5. Declare the designated Analog Input is working OK (not faulted) 
6. Declare that the designated Analog Input is in Calibration 

When a Digital Input is assigned one of the left column Transducers it will initiate the selected operation on that chosen Transducer.









When a Digital Input is assigned one of the right column functions (mA Inputs  ) it will act as a declaration of the status of the external device but otherwise has no control over the analyzer.

**For example**, to assign a Digital Input to Start the Span gas calibration for Transducer #2 (Nitric Oxide or NO) press the  Span Cal icon within the box labelled A in Figure 10-25 then the #2 on the left side of the Panel next to NO.

**As another example**, if the user were to select Ext Cal  and within the box labelled A in Figure 10-25 then mA Input #3  within the box labelled B in Figure 10-25 then it would mean a declaration that the device attached to Analog In #3 is currently in calibration.

*Note: It is important to verify that both device and operation are highlighted before leaving this page because some selections may cause the other buttons to be reset.*



**Table 10-8: Digital Input Icons**

Icon	Meaning	Function
	Digital Inputs Screen	Select a digital input to set up.
	Digital Input #8 Set Up	Set up a specific digital input, in this case #8.
	Auto-Cal	Digital input is selected to trigger the Auto-Cal routine. *
	Stop / Disable Auto-Cal*	Digital input is selected to stop and disable the Auto-Cal routine. *
	Span Calibration*	Digital input is selected to trigger the Span Calibration. *
	Zero or Low Span Calibration	Digital input is selected to trigger the Zero or Low Span Calibration. *
	External Cal	Digital input triggers a declaration that the external device is in Calibration. You select this and then select a mA Input. When the Digital input is triggered the device connected to the mA input would declare it is now in “Service in Progress”.
	External OK	Digital input triggers a declaration that the external device is functioning properly. You select

Icon	Meaning	Function
		this and then select a mA Input. When the Digital input is triggered the device connected to the mA input would declare it is OK.
	mA Analog Input #2	Digital Input is set to control the mA Analog Input #2.

\* Next action - a gas number or a mA Input must then be selected to assign the measurement gas or input to the operation.

## 10.8 Setting the Network Address (Modbus TCP/IP)

Icon	Meaning	Function
	Network Settings	To select the network settings
<b>None</b>		If selected the stored IP address and netmask are set to 0.0.0.0 (and the network stack process is stopped)
<b>IP Static</b>		If selected, you must then touch both the Address Netmask entries to enter values from the numeric keypad. Enter both values then exit this page with the Accept (checkmark) button.
<b>DHCP Active</b>		If selected, the DHCP client will run to obtain ID address and netmask.
	Return	To return to the previous page

## 10.9 Screen Settings



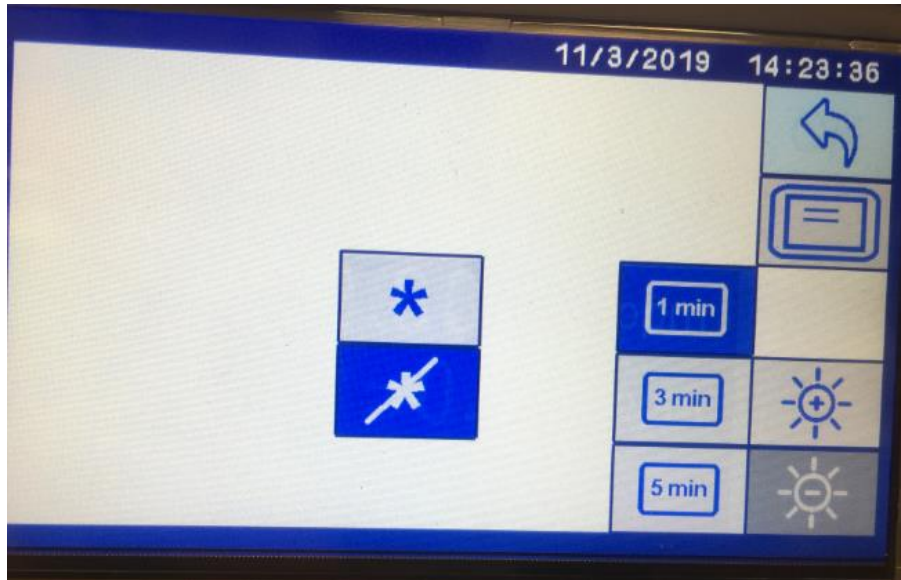



**Figure 10-26: Screen Settings menu**

**Table 10-9: Screen Setting Icons**

Icon	Meaning	Function
	Multiple Gas Display	To show two or more gases on the same screen together on the Home screen. This toggles with the Single Gas Display icon below.
	Single Gas Display	To show a single screen. This icon toggles with the Multiple Gas Display icon above.
	Assign Icons to Favorites ON	If selected User can assign most ICONs to the Favorites Page, this allows quick access from the Main Screen to the assigned ICON page. Up to 12 Favorites can be assigned.
	Hide the Favorites Page	If selected the User will not be able to see the Favorites Page or be allowed to assign any ICON to the page.
	Screen Dim 1 minute	If selected the screen will dim after 1 minute
	Screen Dim 3 minutes	If selected the screen will dim after 3 minutes.
	Screen Dim 5 minutes	If selected the screen will dim after 5 minutes.



Icon	Meaning	Function
	Increase brightness	To increase the screen brightness.
	Decrease brightness	To decrease the screen brightness.
	Return	To return to the previous page

### 10.9.1 Setting an ICON to be a FAVORITE

-  >  >  >  >  >  To Allow FAVORITES
-  >  >  >  >  >  To Hide FAVORITES

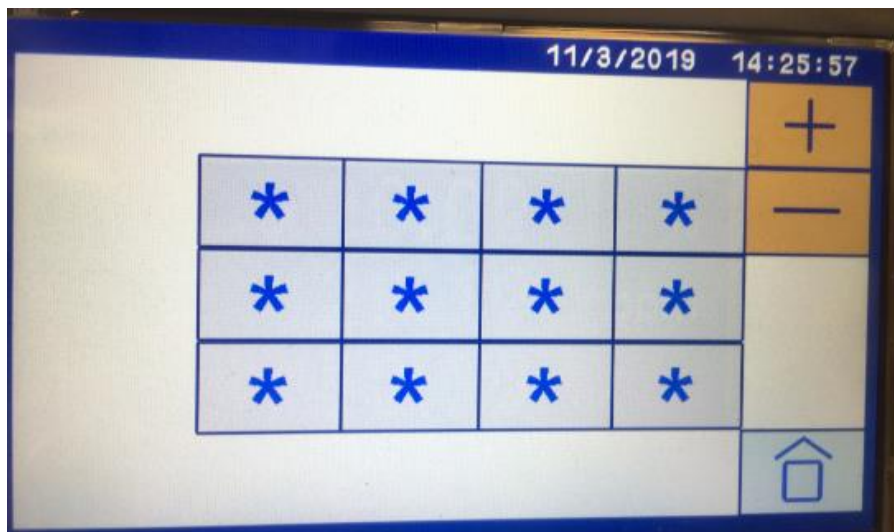









Figure 10-27: Favorites Assignment Page

Table 10-10: Favorites Assignment Icons

Icon	Meaning	Function
	Add Assignment to Favorites	Select this first to Add a new ICON to one of the unassigned slots as a Favorite / Shortcut page (Orange Background with Blue Cross).
	Remove Assignment from Favorites	Select this first to Remove an ICON from the Favorite / Shortcut page (Orange Background with Blue Minus sign).

Icon	Meaning	Function
	Open Favorite Slot	Select this after the  to assign this slot to a specific ICON to the Favorite / Shortcut List.
	Assigned Favorite Slot	Select this after the  to remove the selected ICON from the Favorite / Shortcut List
	Return to Home page	Select this to return to the Home page
	NOT available as a Favorite	When present at the bottom of the page during the process of assigning an ICON to the Favorites Page, this Icon indicates that the selection cannot be assigned (Dark Gray Background with Light Gray Asterix).
	Available as a Favorite	When present at the bottom of the page during the process of assigning an ICON to the Favorites Page, this Icon indicates that the selection can be assigned as a Favorite / Shortcut (Dark Gray Background with Light Gray Cross).

## 10.9.2 Assigning an ICON to be a FAVORITE

In this example we are assigning “Manual Calibration” to the Favorites Icon page.

Touch the  to activate the “Add Assignment” mode (top right-hand corner in Figure 10-28).

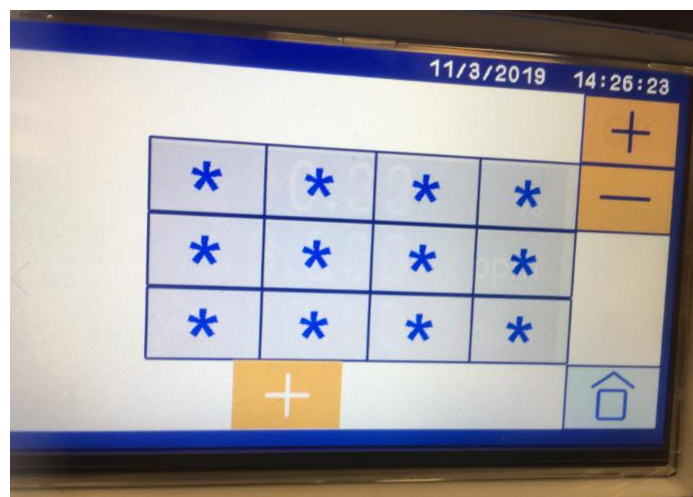





Figure 10-28: Selection of Add Assignment mode

NOTE: that if you touch the Home key at this point it will cancel the “Add Assignment” mode and go back to Home

- a) The  is now activated so touch on any of the open slots  which will bring you to the Main Menu. See Figure 10-29.
- b) Since no Icon is selected at this point the grayed out  “unavailable” icon is showing. See Figure 10-29. You need to select an icon and if the  “available” is present at the bottom of the page then your selection is allowed.

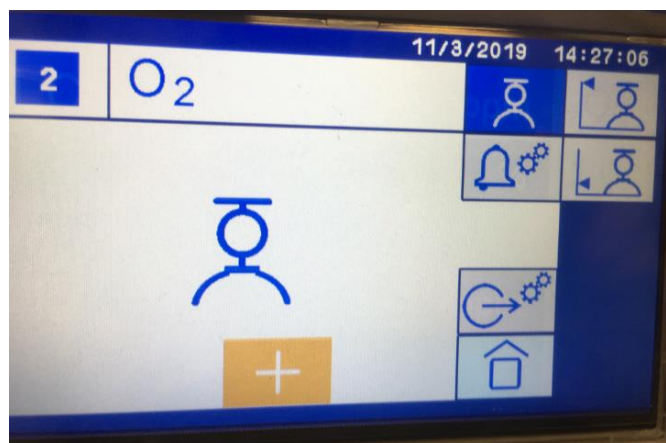

**Figure 10-29: Add Assignment mode activated, no icon selected**

- c) To assign the Manual Calibration section for the O<sub>2</sub>% Transducer (shown in Figure 10-29) to the Favorites touch the following sequence to get to the Manual Calibration Section.



The screen shown in Figure 10-30 will appear.





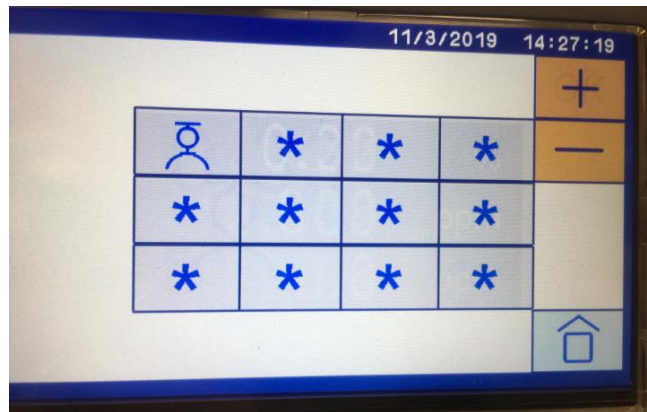

**Figure 10-30: Add Assignment mode activated, manual calibration section**

d) Touch the  icon (see Figure 10-30) to assign the Manual Calibration to the Favorites page as shown below.



**Figure 10-31: Manual calibration icon added to Favorites**

Touch the Home Icon  to return to the HOME page. The Favorites Icon Page can be accessed by touching  (see Figure 10-32). The  is located above the Main Menu icon  for a Multiple Gas screen or just to the left of this icon for a Single Gas screen.

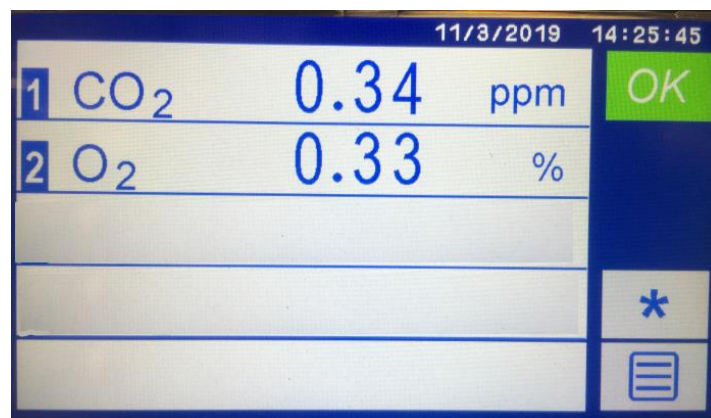

**Figure 10-32: Home Page after an Icon has been added to Favorites**

### 10.9.3 Removing an ICON from the FAVORITES List

To remove an assignment without adding a new one, touch the  key and then touch the ICON you wish to remove from the Favorites List Page.

NOTE: Some Back buttons  operations will take you back to the Favorites Page and some will not once Favorites have been set and used.

NOTE: If Password Protection is activated, you will need the operator password to access the Favorites page each time. You will need the master password to Hide or Not Hide the Favorites as well as to add or remove assignments.

## 10.10 Analog Output Adjustment

Use the Analog Output Adjustment to configure the ranges and set the parameters of the mA outputs.

The Analog Output Range Settings activate auto-ranging and set values for the Expanded, High and Low User ranges for each measurement (Tx #). To make any changes press the following sequence from the Home page.



Detailed information on these adjustments is given in Section 7.3 “Configuring the User Ranges for mA Output and Screen Display.”

The Analog Output Settings are used to adjust the mA output, set the jam mode under fault conditions and behavior during a calibration. To make any changes press the following sequence from the Home page.



Detailed information on these adjustments is given in Section 7.4 “Configure the measurement mA Output.”

## 10.11 Analog Output Assignment

By default, transducers are assigned to the analog output with the same number as the measurement, one transducer per analog output. This section describes how you can assign more than one analog output to a transducer. This can be used if you need to have a separated Low Range and High Range for the same transducer. This feature is available for firmware release 3.1.0 and later.

### 10.11.1 Assigning an Analog Output to a transducer



**Figure 10-33: Home Page showing available measurements**

The Home Page in Figure 10-33 shows each transducer is assigned to a single analog output. For our example, we touch measurement #3 to display the measurement menu.

Touch the Analog Output Settings icon  as shown in Figure 10-34 to reach the Analog Output assignments page.



**Figure 10-34: Measurement page – Analog Output Settings icon**

See Figure 10-35. The Analog Output Assignments page shows the chosen measurement #3/output #3 is highlighted. Outputs #1 and #2 are shown in gray which means they are already assigned. The icon for output #4 is displayed in blue but is not highlighted, which means it is unassigned and available to be assigned.

Touching the icon for output #4 while transducer #3 is highlighted will assign output #4 to transducer #3. The icon for output #4 will now be highlighted (see Figure 10-36). Transducer #3 now has two analog outputs assigned to it.

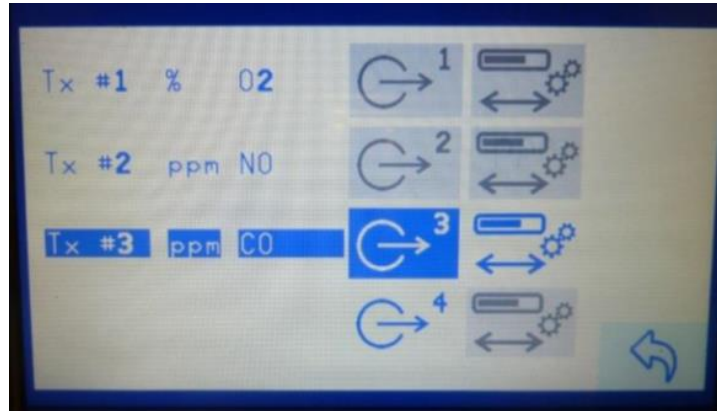

**Figure 10-35: Analog Output Assignments page**

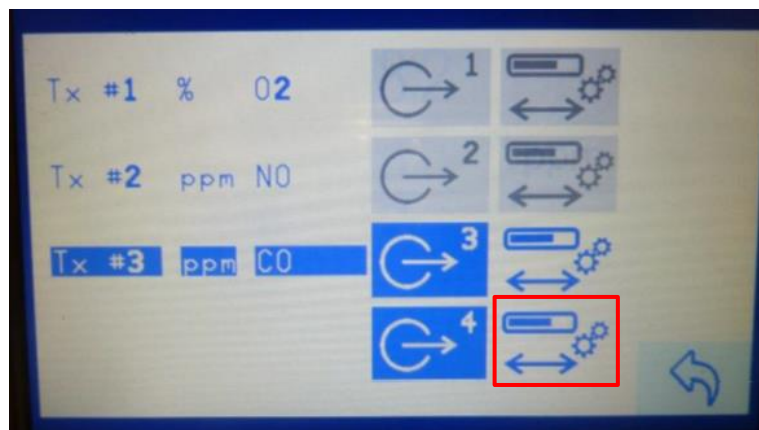

**Figure 10-36: Second Analog Output assigned to transducer**

To adjust the Range Settings for output #4, touch the Range Settings icon for output #4, (ringed in Figure 10-36). See Section 7.3.1 for a description of how to adjust the Range Settings.

The measurement page for measurement #3 will now show two scales, one for each analog output (see Figure 10-37). Compare the measurement page in Figure 10-37 with the one in Figure 10-34.

Note: You will only need to calibrate the higher of the two ranges.



Figure 10-37: Measurement screen showing two analog outputs

### 10.11.2 Unassigning an Analog Output

An analog output may be unassigned from a transducer and made available for another assignment. In Figure 10-38, measurement #1 is highlighted. Touching the highlighted icon for Analog Output #1 (ringed in red) will unassign it from measurement #1. The icon will become blue to show it is available, along with Analog Output # 4.

Note: successive touching of the Analog Output icon will assign and un-assign that output from the highlighted transducer. Touching any of the measurement text will highlight which outputs are currently assigned to the transducer.

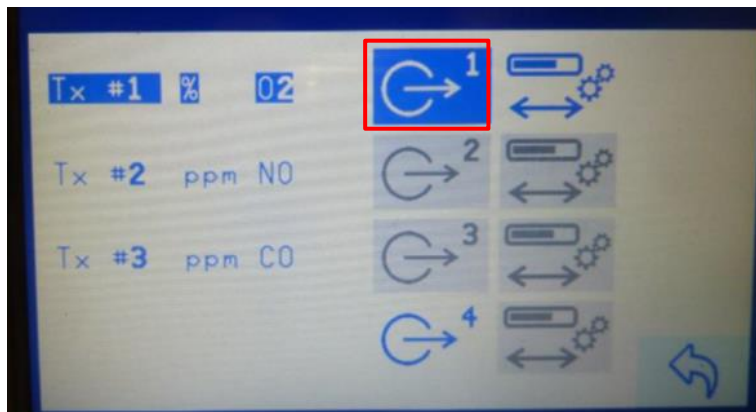



Figure 10-38: Touch marked icon to unassign the Analog Output



## 10.12 Global Block Averaging

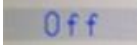

**Figure 10-39: Block Averaging Filter icon**

The block averaging filter icon  is reached through the Settings branch (see Figure 10-39). Touch the  to select the sampling interval (see Figure 10-40). The filter is inactive when  is selected.

When the block averaging filter is active the analyzer gathers up all data during a designated length time interval for each sensor. Available intervals are 1 sec, 2 secs, 5 secs, 10 secs, 20 secs, 30 secs, 60 secs, 90 secs, and 120 secs. When the time interval is up it reports a single average for that time and begins gathering the next interval's data. For example, if the interval is set for 5 sec, new measurements are reported only every 5 seconds and the value is the average from the preceding 5 seconds up to that report.

The block averaging is a global setting that applies to all the transducers. The block averaging takes place after any sensor-specific filtering has been applied.

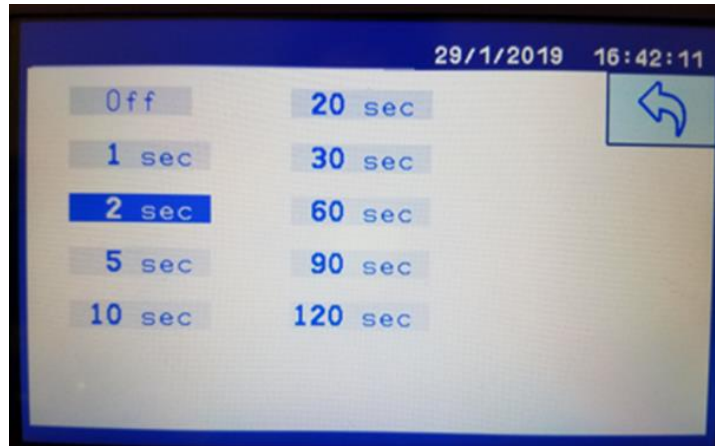

Figure 10-40: Block Averaging Filter menu

# 11 Manual Calibration and Auto-Cal Sequences

---

## 11.1 Definition of Terms Used

Calibration means that the transducer calibration curve will be changed. Validation means that the analyzer will measure the gas concentration and then check the value against a user input certified value. The user input certified value for the High Span calibration point value will be from the tag value (certified concentration value) of a gas bottle while the Low Span point is generally set to "0". Each transducer calibration (or validation) process must be set up individually and then can be accessed manually or automatically.

If the Auto-Cal feature is purchased, more than one transducer can be calibrated automatically at the same time using a mixed gas blend containing all required gases at the Span concentration values. The timing sequence for all of the transducers in this case will need to be set to the same time and date and the Zero, Span and Sample Measure times must be the same as well.

This section steps through the process of setting up a manual calibration and the Auto-Cal sequences.

## 11.2 Introduction to Calibration

The calibration of the transducers in the analyzer may be checked or adjusted either manually or automatically (requires the Auto-Cal option) and the activity will be logged as an entry in the calibration history log. The Auto-Cal feature allows the user to set up to three automatic timing sequences on each of the transducers. These sequences can be any combination of calibration or validation processes (described in Section 11.6).

External valves or a single multiport switching valve will need to be installed by the customer to enable the use of the various Span and Zero gases as well as the Sample gas stream. These valves can then be assigned to the relays associated with each transducer for controlling Zero, Span and Sample gas. For the Auto-Cal option three relays per transducer will be pre-assigned as Zero, Span and Sample mode automatically.

If the analyzer is still warming up a (  ) symbol will appear in the corner for each of the gas icons. If a calibration is attempted, a warning message will appear with an option to proceed. As each gas transducer warms up this symbol will disappear and at this time a calibration or validation can be performed on that transducer.

*Note: For optimal performance, allow the analyzer to run and stabilize for at least 24 hours from a cold start at 20°C (68°F). For the higher sensitivity measurements, this time may be longer.*

The operator is guided through the setup sequence choices by a series of menus, icons, and editable text. Each gas sensor / transducer parameter including output concentration units, triggers and ranges, must be setup individually.

If the Auto-Cal feature is purchased, then the relevant menus and icons will be activated on the touchscreen. The Auto-Cal can be setup so that the transducers are calibrated or validated serially (one after another) or timed so that they run simultaneously.

The Auto-Cal process can be initiated by setting up an internal timer, using an external contact closure or manually through the user interface or triggered via a digital input signal. In all cases if any of these events occur when the Auto-Cal cycle is in process it will ignore the request.

The instrument will only respond to a request for an Auto-Cal from the internal timer or external input if there are no faults indicated. However, the operator can use the analyzer interface to initiate the Auto-Cal sequence even if there is still a fault displayed.

*Note: If the Auto-Cal option has been purchased, the pre-assigned relays will be activated when performing a manual span calibration and zero calibration, and at their completion, the sample gas relay will be activated.*



**Whenever you are calibrating the instrument, flush analyzer with inert gas to prevent user exposure to a toxic or flammable gas.**

### 11.3 Calibration Gas Standard Requirements

Zero and Span gas standards are required to perform the calibration of each of the transducers fitted into the analyzer. Tolerances and Span bottle certified concentration values must be inputted for each transducer individually and updated when a cylinder bottle is replaced.

The quality of the gas standards used will greatly impact the results of the measurement. Servomex recommends the use of certified gravimetric gas blends and mixtures for the calibration of the MultiExact 4200 analyzer. For highest accuracy use gases from a supplier that participates in a rigorous regulatory oversight program such as the US EPA Protocol Gas Verification Program or equivalent programs provided by the European and Asian National Metrology Institutes. While calibration standards of  $\pm 2\%$  accuracy are acceptable, standards of  $\pm 1\%$  accuracy afford the highest accuracy.

Gas standards can be either simple binary mixtures of a span gas and a standard carrier gas such as N<sub>2</sub> or Air, or more complicated mixtures provided the mixture is stable and will not change over time. If unsure, follow the regulatory guidelines for the region or country.

See Appendix G for a listing of all of the transducers and their full-scale range values, and Appendix G, Appendix H and Appendix I for details including suggested SPAN values for the purchased transducer concentration range for the Single Beam Single Wavelength (SBSW) non-dispersive infrared (NDIR), Paramagnetic oxygen and the NDIR Gas Filter Correlation (GFX) transducers respectively.

## 11.4 Recommended calibration periods

It is recommended that the calibration of the gas sensors be checked on a regular basis and recalibrated, if required, for best performance. The table below shows the recommended periods based upon transducer type. Use Appendix G (SBSW CO% and CO<sub>2</sub>%), Appendix H (O<sub>2</sub>%), and Appendix I (GFX) to determine which transducer type is in the analyser.

*Note: More frequent calibration or validation periods may be required by the regional regulatory body if the analyzers are used in regulatory monitoring such as continuous emissions monitoring (CEM) systems.*

Gas transducer module	Low / Zero calibration	High / Span calibration
SBSW NDIR transducer	Weekly	Daily
Paramagnetic O <sub>2</sub> transducer	Weekly	Weekly
GFX NDIR transducer	Weekly	Monthly

**Hint:** *The required calibration interval depends on the reliance that you place upon the accuracy and consistency of the measurements made by the analyzer. Adjust the calibration interval according to your requirements and the drift characteristics of your analyzer.*

## 11.5 Manual calibration

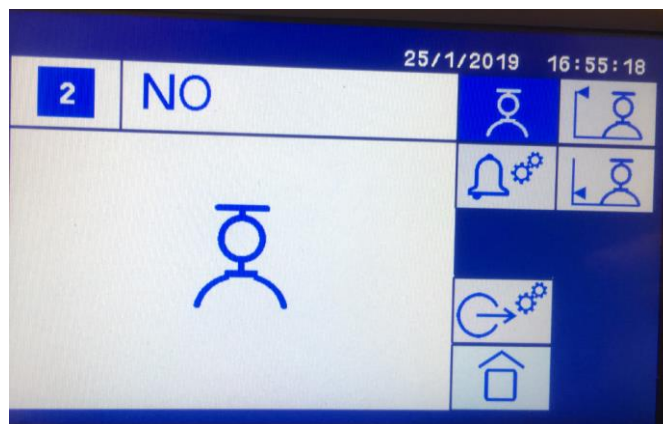







Figure 11-1: Calibration screen (manual calibration activated)





The Manual calibration mode requires the user to manually trigger the transducer calibration when a Span gas is flowing for the High Span value and when a Zero or Low concentration gas is flowing for the Low Span / Zero value.

**Table 11-1: Manual Calibration Icons**

Icon	Meaning	Function
	High Span	To set the High Span calibration value based upon the bottle certified concentration.
	Zero or Low Span	To set the Low Span calibration point, generally set to "0" using a zeroing gas like Nitrogen.
	Measurement Alarm Settings	Touch this icon to set the measurement alarm values for the transducer.
	Analog Output Adjustment	Touch this icon to set the parameters for the analog output
	Home	Return back to the system Home screen.

### 11.5.1 Manual calibration of High Span

Make sure that your equipment is configured to correctly route your high span calibration gas supply to the analyzer sample gas inlet.

1. Run the High Span calibration gas through the analyzer and wait 15 minutes.
  - a. Allow the span value to stabilize for one minute.
  - b. Touch the high span measurement  icon shown on the screen (see Figure 11-1).
2. The new screen (see Figure 11-2) will display the target value along the top bar.
  - a. The target value will be the last span value that was used to calibrate that transducer.
  - b. If the target value is not correct for the calibration gas you are using, change the target value to the certified gas bottle concentration value using the numeric keypad (see Figure 11-2).
  - c.  accepts the new entry,  deletes the last typed value and  cancels the entry.



**Figure 11-2: Span value entry keypad with Target Value on the top bar**

3. Press  to accept the new entry and launch the manual calibration run screen shown in Figure 11-3.

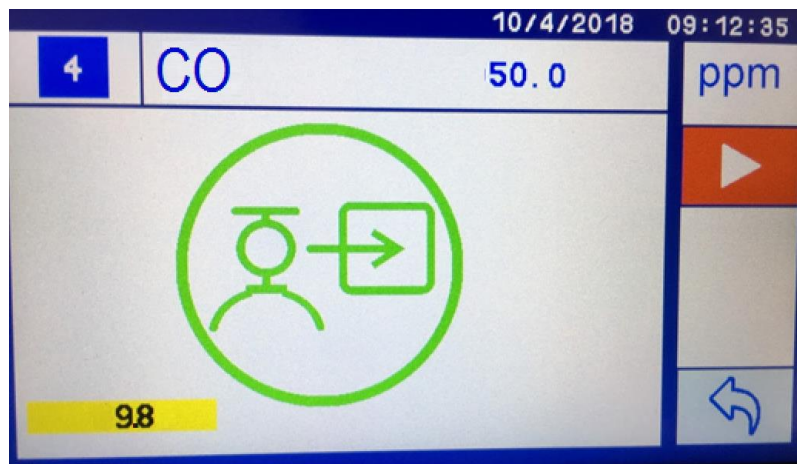





**Figure 11-3: Start calibration – gas filling state**

- a. A “Service in Progress” signal is triggered, the gas is flowing through the transducer and the sequence of the calibration step is displayed at the bottom of the screen in Yellow.
- b. The Run  icon will stay red (see Figure 11-3) while the gas measured value is:
  - For High Span: less than 80% of the High Span target value (in the example above this would be  $\geq 40$  ppm).
  - For Zero / Low Span: greater than 20% of the High Span target value (in the example above this would be  $\leq 10$  ppm).





**Figure 11-4: Start calibration – READY State**

- c. When the gas measured value is near to the target value the Run  icon will turn from RED to GREEN (Figure 11-4).
    - For High Span: >80% of the High Span target value (in the example above this would be  $\geq 40$  ppm).
    - For Zero / Low Span: < 20% of the High Span target value (in the example above this would be  $\leq 10$  ppm).
  - d. Calibration is started by pressing the Run  icon
  - e. When the calibration is finished it reverts back to the screen displaying the gas reading (see Figure 11-2) to show the post-calibration reading.
4. To repeat the calibration, touch the Run  icon again.
  5. When the calibration procedure is finished touch the Back  icon to terminate “Service In Progress” and bring up the measurement screen (Figure 11-1).









*Note: The User can over-ride the warning given by the Run  icon by touching the icon. The Calibration sequence will continue even though the measured gas value is not near the target value. This is not recommended as the red icon may be flagging there is something wrong with the sampling system, the calibration gas or the transducer.*



## 11.5.2 Manual calibration of Zero or Low Span

1. Run the Low Span or Zero calibration gas through the analyzer and wait 15 minutes.
  - a. Allow the displayed value to stabilize for one minute.
  - b. Touch the Low Span or Zero measurement  icon shown on the screen in Figure 11-1.
2. Repeat steps 2 through 5 in Section 11.5.1 to calibrate the Zero / Low Span measurement .

**Table 11-2: Manual High Span and Zero Icons**

Icon	Meaning	Function
	High Span	Set the High Span calibration value based upon the bottle certified concentration.
	Zero or Low Span	Set the Low Span calibration point, generally set to "0" using a zeroing gas like Nitrogen.
	Run Calibration with measured value <20% away from target.	Start the Manual Calibration run. The icon turns green when the measured value is within 20% of the Target value.
	Run Calibration with measured value >20% away from target.	Start the Manual Calibration run but note that the measured value is not close to the target value. The icon stays red until the measured value is within 20% of the Target value.
	Terminate Service in Progress	Stop the calibration or validation process.
	Delete Last	Delete the last digit typed in.
	Return	Accept the value entered in the keypad. Typing in "0" on the keypad will stop the data recording if the Return key is pressed.
	Cancel	Cancel the value entered in the keypad.

## 11.6 Auto-Cal validation and calibration sequences



The optional Auto-Cal feature provides validation and calibration sequences that can be triggered automatically. The validation sequences allow the user to validate the reading against preset Zero and Span gas value and tolerance. The calibration sequences allow validation followed by calibration to update the transducer calibration equation.

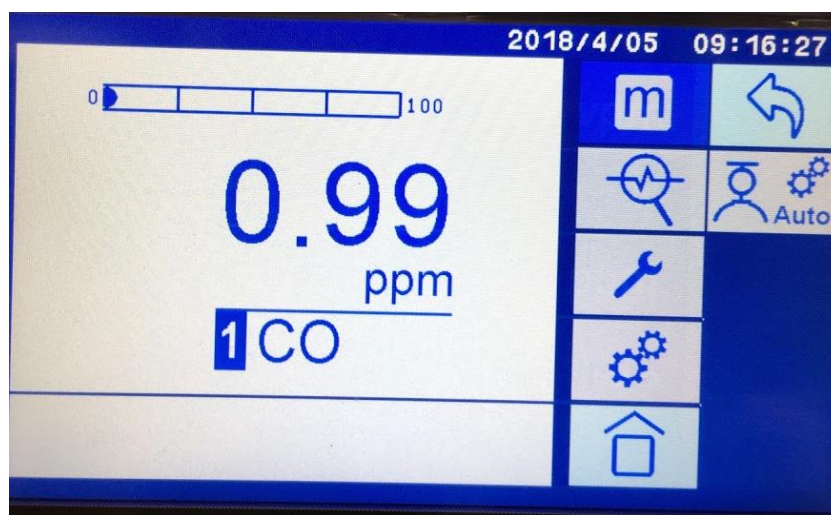

Figure 11-5: Auto-Cal main screen

Any of the sequences can be set to run at user chosen times and dates automatically. To validate or calibrate multiple transducers at the same time using a gas blend then each transducer date, time and repeats must be set up to be the same. The Span value for the Calibration or Validation must then be added for each gas transducer based upon the certified value of that gas constituent in the blended cylinder.

External valves or a single multipoint switching valve will need to be installed and connected to the transducer relays by the customer to enable the “Service in Progress” signal and the Auto-Cal routine to trigger the Zero, Span and Sample modes on each transducer.

If more than one transducer is present in the analyzer then all of the transducers will turn Yellow indicating they are no longer producing “good” sample gas readings and are in the “Service in Progress” mode (see Figure 11-6). Transducers that are in the Auto-Cal or Auto-Val sequence will show up as black text on the screen while those that are not in progress are in grey text. In Figure 11-6 the NO and SO<sub>2</sub> gas transducer sequence timings were configured to be the same and they are undergoing Auto-Cal simultaneously as indicated by the BLACK text.



**Figure 11-6: Calibration or Validation “Service In Progress” screen**

When Auto-Cal is purchased a manual validation check or calibration adjustment can still be made, using the same transducer relays and valves established in the Auto-Cal configuration.

The auto-validation and auto-calibration processes can be initiated by four methods:

1. by an internal timer;
2. by an external contact closure;
3. by operator manual request using the analyzer front panel user interface;
4. by an external Modbus or PROFIBUS command

The instrument will only respond to a request for Auto-Cal from the internal timer or external input if there are no faults indicated. Auto-Cal can be initiated from the user interface when there is a fault condition.

If any one of these events occurs while the Auto-Cal cycle is in progress the request will be ignored. Touching the keypad during Auto-Cal will initiate the abort sequence.

The Auto-Cal feature offers custom configurations for automatic Validation and Calibration operations. The general sequence uses three gas streams (Zero, Span and Sample) and the Zero gas or the Span gas can be skipped by setting the timing (t1, t2..) to zero, skipping that step.

Up to three sequences can be assigned to each transducer (see Figure 11-7). They can be of any form of auto-calibration or auto-validation as needed.

For example, if you need to perform a daily Zero and Span check / validation then you could assign this to sequence #1 using the auto-validation function. In sequence #2 you might assign a weekly auto-calibration sequence.

*Note: The internal analyzer timer will trigger all the Auto-Cal sequences without any external input required. However, if an external input is used to trigger the Auto-Cal then only the first sequence will commence.*

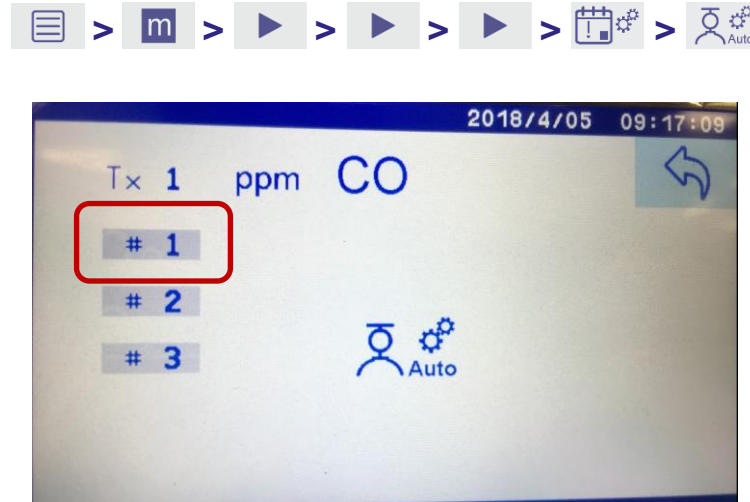

**Figure 11-7: Sequence setup screen - #1 is shown in the box**

An overview of how the Auto-Cal validation sequences are handled is given in Section 11.7 and an overview of how the Auto-Cal calibration sequences are handled is given in Section 11.8.

## 11.7 Auto-validation sequence steps

### 11.7.1 Auto-validation flow diagram

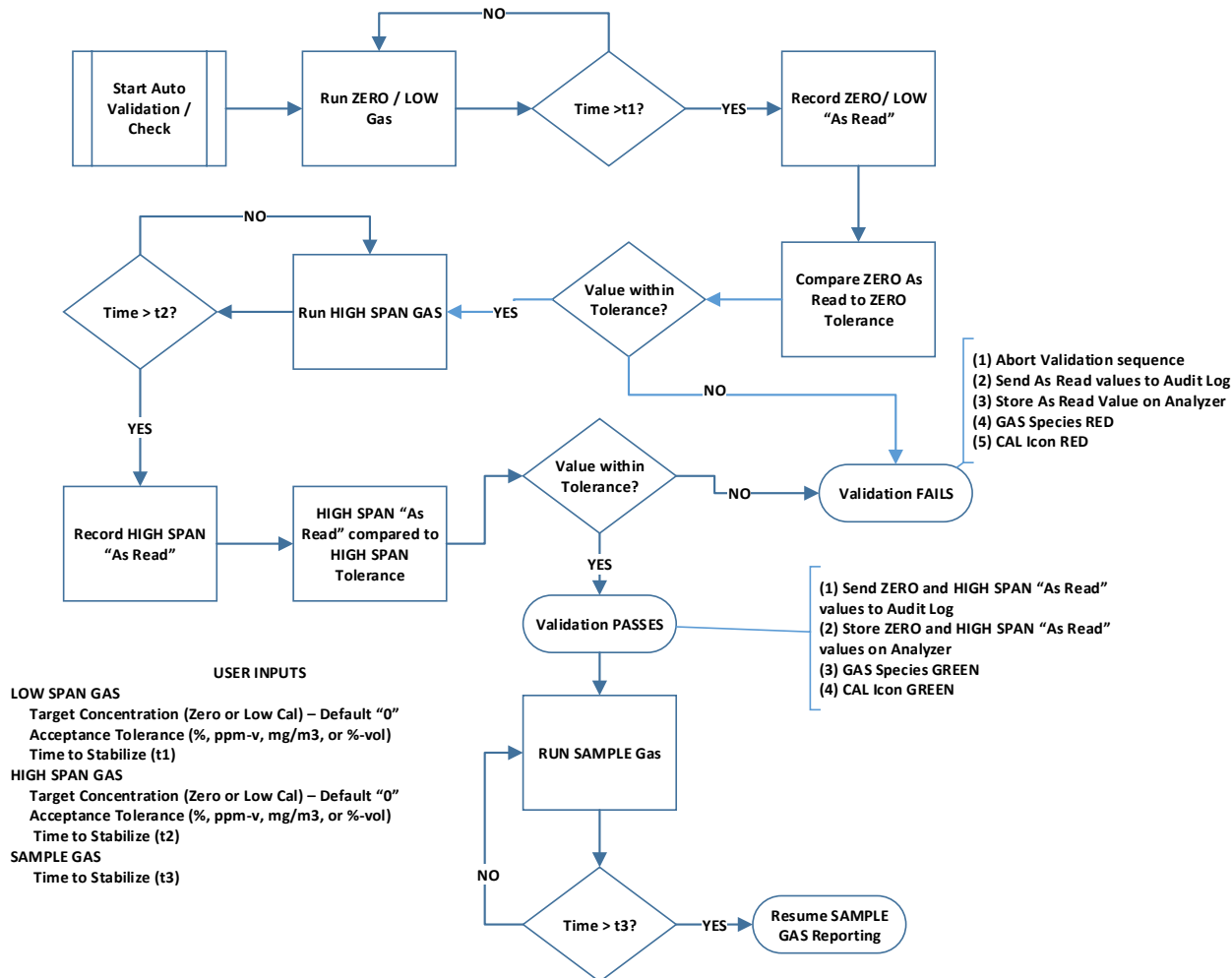

Figure 11-8: Flow diagram of the Auto-Validation steps

### 11.7.2 Auto-validation full sequence example

The full sequence for auto-validation is shown in Figure 11-9 providing a simple Pass or Fail result. Even if the sequence fails, the gas sample measurements can continue to report values. Figure 11-9 and Table 11-3 describe how the auto-validation sequence works. Each transducer must be set up separately to perform an auto-validation.

If you want two or more of the transducers to run auto-validation simultaneously then the sequence timing as well as the Date and Time settings need to be the same.

Note: If the Zero or Span Validation step fails the Transducer gas icon will remain RED until the user corrects the problem, gas measurement reporting will continue however.

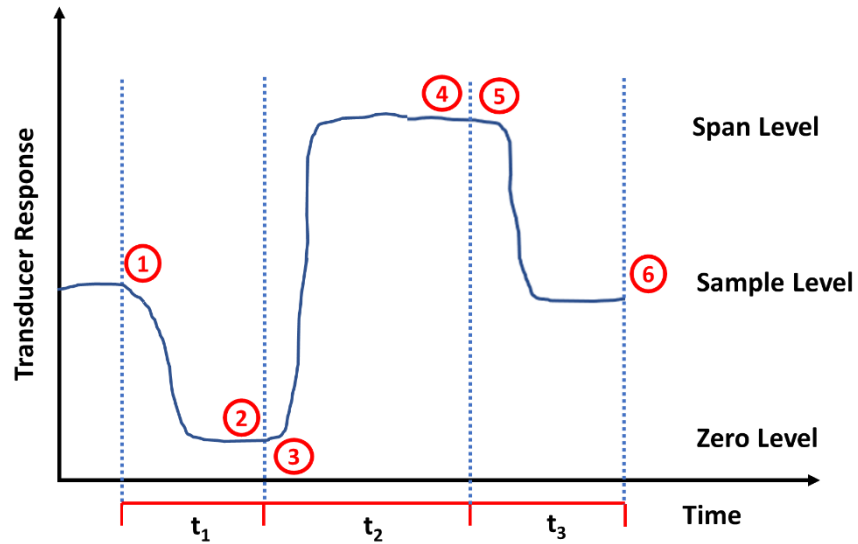

Figure 11-9: Full auto-validation sequence

Table 11-3: Typical auto-validation sequence on a transducer

Point	Function
1	Zero gas routed to transducer and set <b>Service In Progress</b> flag and turn on any <b>Service In Progress</b> relays.
t1	Time required for Zero gas readings to stabilize.
2	Zero gas "As Found" value recorded and compared to "0" $\pm$ tolerance. If Zero gas "As Found" value Passes - Skip to Point 3. If Zero gas "As Found" value Fails – Log Failure and turn Gas icon and Auto-Cal icon RED.
3	Span gas routed to transducer.
t2	Time required for Span gas readings to stabilize.
4	Span gas "As Found" value recorded and compared to High Span value $\pm$ tolerance. If Span gas "As Found" value Passes - Skip to Point 5. If Span gas "As Found" value Fails – Log Failure and turn Gas icon and Auto-Cal icon RED.
5	Sample gas routed to analyzer.

Point	Function
<b>t3</b>	Time required for Sample gas readings to stabilize and begin reporting gas measurements. This cannot be set to "0" and is defaulted to 1 sec before restoring the measurement values.
<b>6</b>	Clear <b>Service In Progress</b> and turn off any <b>Service In Progress</b> relays and begin reporting Sample gas measurements.
<b>Final output will be Pass or Fail flag</b>	

### 11.7.3 Auto-validation truncated sequence example

The next sequence below describes how to skip the Zero portion of the auto-validation sequence, performing only a Span Check in the auto-validation (see Figure 11-10 and Table 11-4).

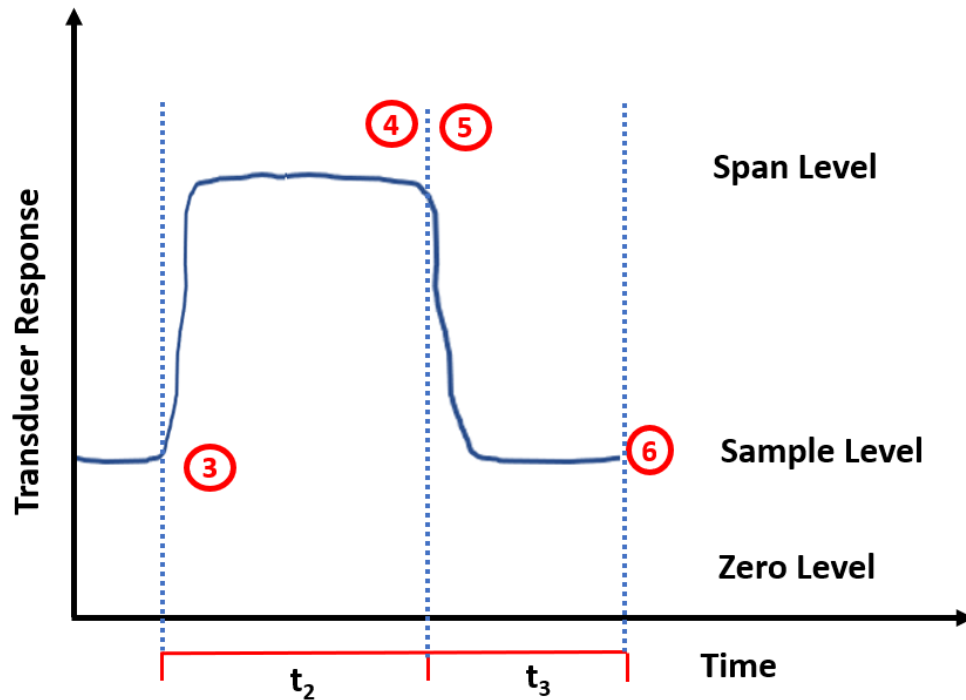

Figure 11-10: Auto-Validation Span Check only sequence

Table 11-4: Auto-validation Span only sequence on a transducer

Point	Function
<b>1</b>	Zero gas switch to analyzer skipped as $t_1$ set to "0"
<b>t1</b>	Zero gas Time set to "0"
<b>2</b>	Zero gas "As Found" read and comparison skipped as $t_1$ set to "0"

<b>Point</b>	<b>Function</b>
<b>3</b>	Span gas routed to transducer and set <b>Service In Progress</b> flag and turn on any <b>Service In Progress</b> relays.
<b>t2</b>	Time required for Span gas readings to stabilize.
<b>4</b>	Span gas "As Found" value recorded and compared to High Span value $\pm$ tolerance.  If Span gas "As Found" value Passes - Skip to Point 5.  If Span gas "As Found" value Fails – Log Failure and turn Gas icon and Auto-Cal icon RED.
<b>5</b>	Sample gas routed to analyzer.
<b>t3</b>	Time required for Sample gas readings to stabilize and begin reporting gas measurements. This cannot be set to "0" and is defaulted to 1 sec before restoring the measurement values.
<b>6</b>	Clear <b>Service In Progress</b> and turn off any <b>Service In Progress</b> relays and begin reporting Sample gas measurements.
<b>Final output will be Pass or Fail flag</b>	



## 11.7.4 Auto-validation setup screen

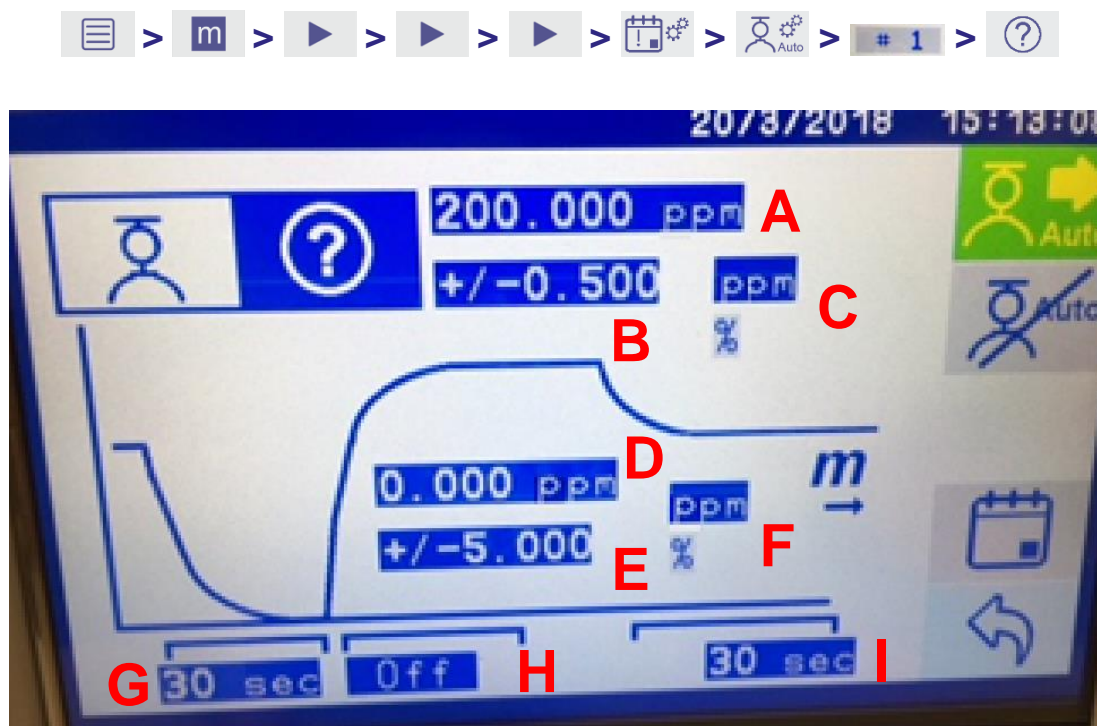





Figure 11-11: Auto-validation setup screen is active (t2 is skipped)

Table 11-5: Auto-Validation setup screen input function labels for Figure 11-11



Symbol	Function
A	Touch this text box to enter High Span concentration bottle tag / certified value (shown as 200.000 ppm tag value).
B	Touch this text box to enter High Span concentration tolerance value as a percentage of the High Span value or a fixed value (shown as $\pm 0.500$ ppm fixed concentration value).
C	Touch this text box to enter High Span concentration tolerance units as concentration (ppm, mg/m <sup>3</sup> or %-v) or a percent of the span value (shown as ppm).
D	Touch this text box to enter Zero or Low Span concentration bottle tag / certified value. Default is 0.000 (shown as 0.000 ppm value).
E	Touch this text box to enter Zero or Low Span concentration tolerance value as a percentage of the High Span value or a fixed value (shown as $\pm 5.000$ ppm fixed value).



Symbol	Function
<b>F</b>	Touch this text box to enter Zero or Low Span concentration tolerance units as concentration (ppm, mg/m <sup>3</sup> or %-v) or a percent of the span value (shown as units as ppm).
<b>G</b>	Touch this text box to enter Time required for Zero gas readings to stabilize, then take an “As Found” reading (see Section 11.7.2 for location of #1,t1,#2). Shows t1 as 30 seconds.
<b>H</b>	Touch this text box to enter Time required for High Span gas readings to stabilize, then take an “As Found” reading (see Section 11.7.2 for location of #3,t2,#4). Shows t2 as Off indicating the High Span Validation check section will be skipped.
<b>I</b>	Touch this text box to enter Time required for Sample gas readings to stabilize before measurement reporting begins reading (see Section 11.7.2 for location of #5, t3, #6). Shows t3 as 30 seconds.
	Symbol showing where Measurement of Sample begins. Has no function.

Touch the Start Auto-Cal icon  to run the auto-calibration/validation sequence straight away or touch the Calendar icon  to set a time for the auto-calibration/validation sequence to start.

*Note: To abort the auto-calibration/validation set-up sequence touch . It will also cancel any future events so have care when using this function.*

**Table 11-6: Auto-Validation setup screen icons**

Icon	Meaning	Function
	Auto-calibration settings	Selects the auto-calibration sequence setup screen.
	Auto-validation settings	Selects the auto-validation sequence setup screen. Blue background indicates active function.
	Auto-Cal Timing	Sets up the timing for the auto-calibration and auto-validation sequences. Up to 3 sequences can be set for each transducer.

Icon	Meaning	Function
	Start Auto-Cal	Forces the current auto-calibration or auto-validation sequence on the screen to be executed.
	Stop Auto-Cal	Disables or cancels the auto-validation or auto-calibration sequence that is in progress. Be careful with this function as it also cancels any future timed events.
	Return	Returns the screen to the main Maintenance Menu.

## 11.8 Auto-Calibration Sequence Steps

### 11.8.1 Auto-Calibration Sequence Flow Diagram

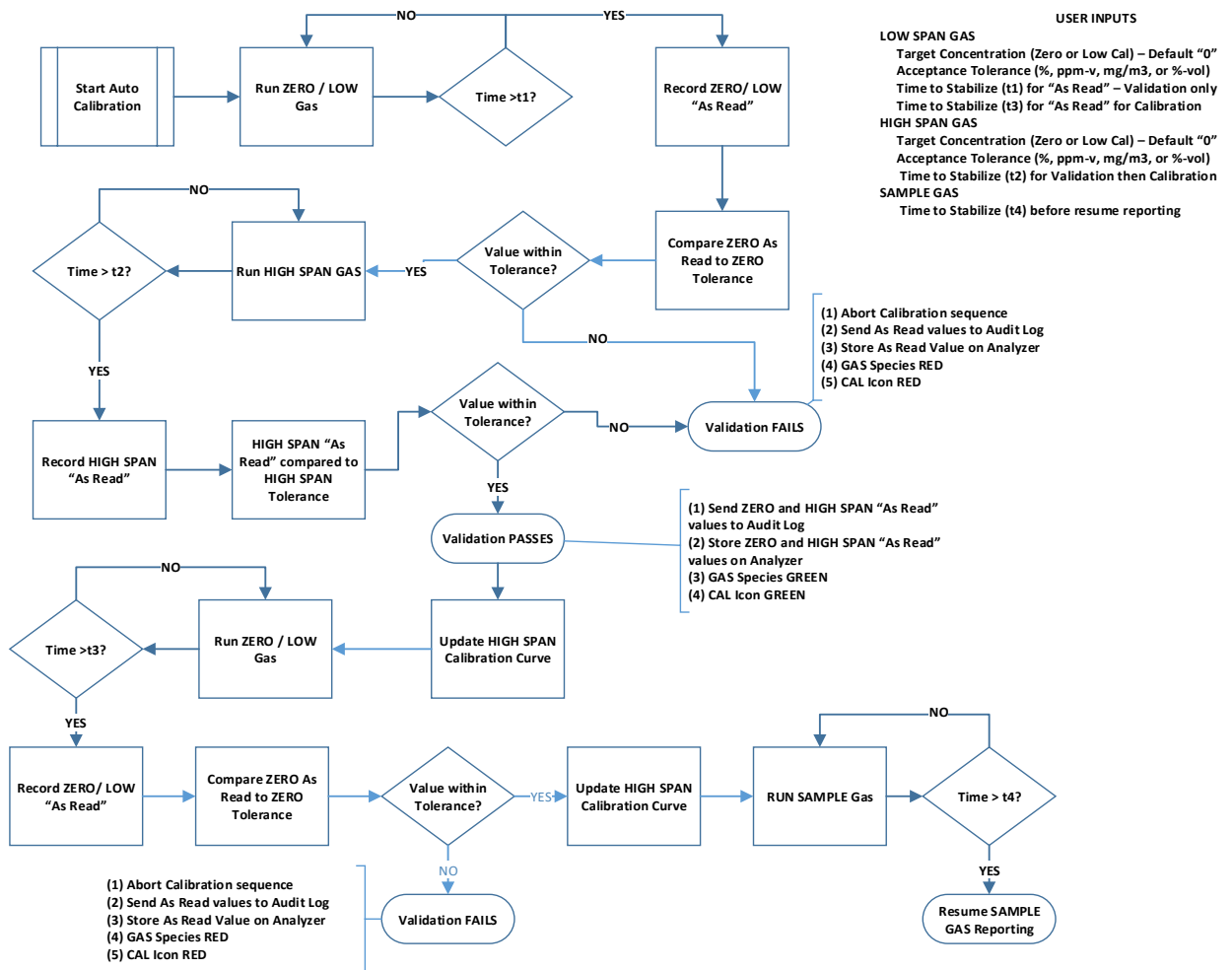

Figure 11-12: Flow diagram of the Auto-Calibration Steps

### 11.8.2 Auto-Calibration full sequence example

The full sequence for Auto-Calibration is shown in Figure 11-13 providing a new calibration curve for the transducer if the validation step passed otherwise the calibration step will not be performed. Even if the sequence fails, the gas sample measurements can continue to report values, but a manual calibration must be done if the validation sequence fails. The user should check to ensure the gas sampling system is working properly and the calibration gas standards are accurate before attempting another calibration after a failure.

The full sequence Auto-Calibration process reads the Zero gas “As Found” value then switches to the Span gas to read the “As Found” value, both performed before any

calibration curve changes. The second Zero gas “As Found” process is used to set the Zero calibration point.

Figure 11-13 and Table 11-7 describe how the full Auto-Calibration sequences works and Section show how to set timing, concentration and threshold limit values. Each transducer must be set up separately in order to perform an Auto-Calibration.

*Note: If the Zero or Span Validation step fails the Transducer gas icon will remain RED until the user corrects the problem, gas measurement reporting will continue however.*

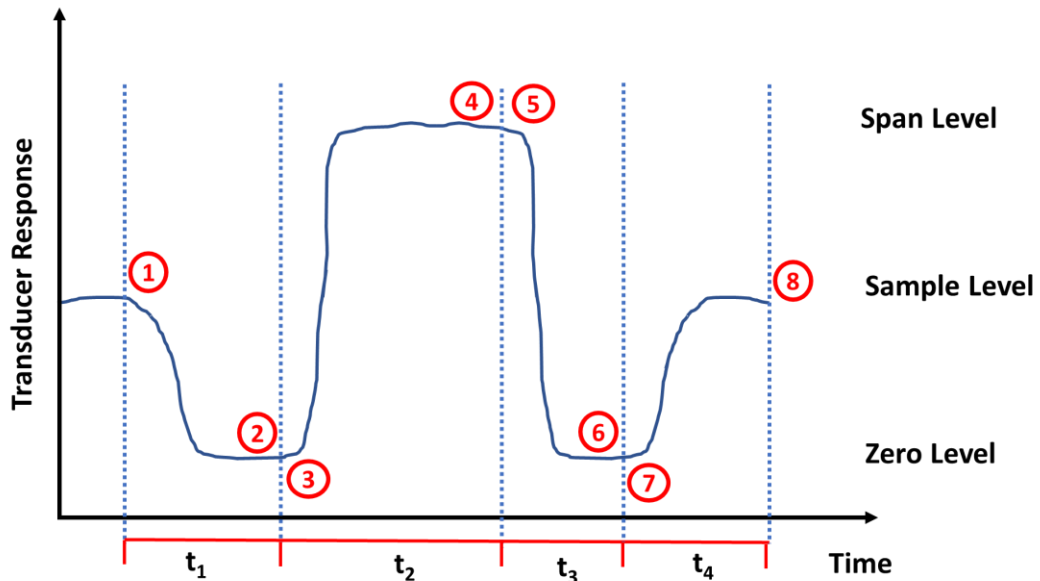

**Figure 11-13: Full Auto-Calibration sequence**

**Table 11-7: Typical Auto-calibration processes on a transducer**

Symbol	Function
1	Zero gas routed to transducer and set <b>Service In Progress</b> flag and turn on any <b>Service In Progress</b> relays.
t1	Time required for Zero gas readings to stabilize.
2	Zero gas “As Found” value recorded and compared to “0” ± tolerance. If Zero gas “As Found” value Fails – then Auto-Calibration sequence is terminated, Validation Failure is issued.
3	Span gas routed to transducer.
t2	Time required for Span gas readings to stabilize.

Symbol	Function
4	Span gas "As Found" value recorded and compared to High Span value $\pm$ tolerance.  If Span gas "As Found" value Passes - Calibrate to High Span value. Skip to Point 5.  If Span gas "As Found" value Fails – then Auto-Calibration sequence is terminated, Validation Failure flag is issued, and the Gas Component and Auto-Cal icon turn RED. Skip to Point 7 and switch gas to sample stream.
5	Zero gas routed to analyzer.
t3	Time required for Zero gas readings to stabilize.  If Zero gas "As Found" value Passes Calibrate to Low Span value which is generally "0". Skip to Point 7.  If Zero gas "As Found" value Fails – then Auto-Calibration sequence is terminated, Validation Failure flag is issued, and the Gas Component and Auto-Cal icon turn RED. Skip to Point 7 and switch gas to sample stream.
7	Sample gas routed to analyzer.
t4	Time required for Sample gas readings to stabilize and begin reporting gas measurements.
8	Clear <b>Service In Progress</b> and turn off any <b>Service In Progress</b> relays and begin reporting Sample gas measurements.
<b>Final output will be Pass (Recalibration) or Fail (No Calibration, Failure Flag set, Switch to Sample gas)</b>	

### 11.8.3 Auto-calibration truncated sequence example

Figure 11-14 and Table 11-8 describe how the auto-calibration sequences can be configured to skip the first Zero "As Found" validation section and only use the second Zero "As Found" validation test followed by a calibration. In Figure 11-14 the Span "As Found" value is obtained prior to performing any calibration curve changes, while the Zero "As Found" value is obtained after the Span High Calibration point has been changed.

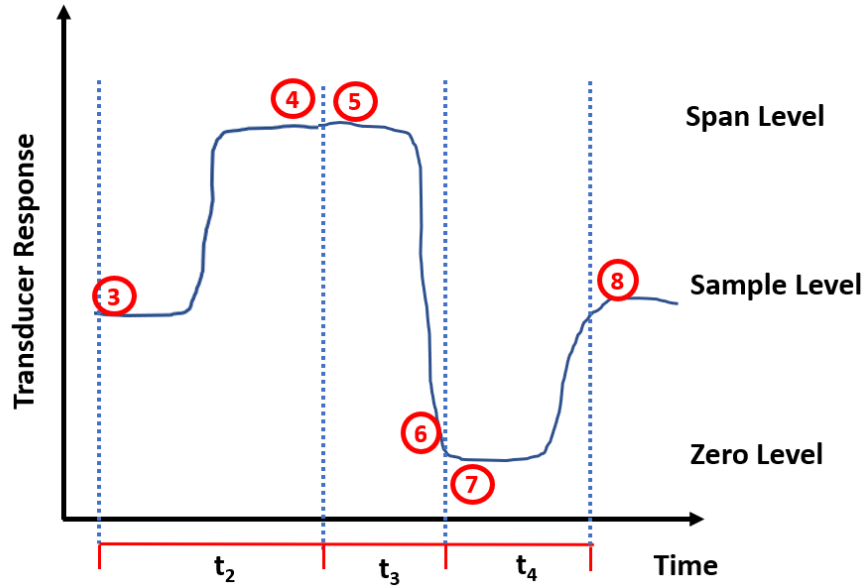

Figure 11-14: Auto-calibration without Initial Zero “As Found” read.

Table 11-8: Auto-calibration without Initial Zero “As Found”

Symbol	Function
1	Zero gas switch to analyzer skipped as t1 set to “0”
t1	Zero gas Time set to “0”
2	Zero gas “As Found” read and comparison skipped as t1 set to “0”
3	Span gas routed to transducer and set <b>Service In Progress</b> flag and turn on any <b>Service In Progress</b> relays.
t2	Time required for Span gas readings to stabilize.
4	Span gas “As Found” value recorded and compared to High Span value $\pm$ tolerance.  If Span gas “As Found” value Passes - Calibrate to High Span value. Skip to Point 5.  If Span gas “As Found” value Fails – then auto-calibration sequence is terminated, Validation Failure flag is issued, and the Gas Component and Auto-Cal icon turn RED. Skip to Point 7 and switch gas to sample stream.
5	Zero gas routed to analyzer.
t3	Time required for Zero gas readings to stabilize.

Symbol	Function
6	<p>Zero gas “As Found” value recorded and compared to Low Span “0” value <math>\pm</math> tolerance.</p> <p>If Zero gas “As Found” value Passes Calibrate to Low Span value which is generally “0”. Skip to Point 7.</p> <p>If Zero gas “As Found” value Fails – then auto-calibration sequence is terminated, Validation Failure flag is issued, and the Gas Component and Auto-Cal icon turn RED. Skip to Point 7 and switch gas to sample stream.</p>
7	Sample gas routed to analyzer.
t4	Time required for Sample gas readings to stabilize and begin reporting gas measurements. This cannot be set to “0” and is defaulted to 1 sec before restoring the measurement values.
8	Clear <b>Service In Progress</b> and turn off any <b>Service In Progress</b> relays and begin reporting Sample gas measurements.
<b>Final output will be Pass (Recalibration) or Fail (No Calibration, Failure Flag set, Switch to Sample gas)</b>	

**Hint:** *The key difference between the sequences shown in Figure 11-13 and Figure 11-14 is that there is no initial Zero “As Found” value recorded in the sequence shown in Figure 11-14. The sequence in Figure 11-13 will support regulatory compliance where both the Zero gas and the Span gas “As Found” readings need to be recorded prior to any calibration curve changes from the High Span or the Low / Zero Span calibrations.*



## 11.8.4 Auto-calibration screen setup

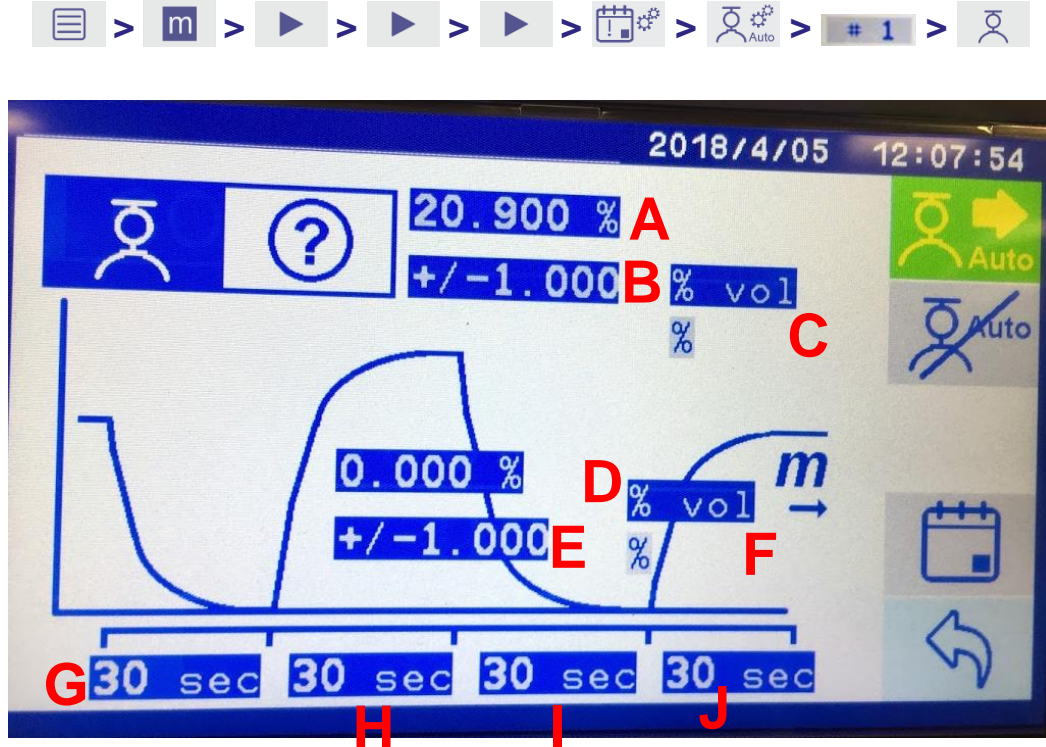



Figure 11-15: Auto-calibration setup screen is active



Up to 3 sequences can be set up on each transducer as a mixture of auto-calibration and auto-validation sequences (see Section 11.6). These sequences are initiated by the internal timer and do not require an external trigger for execution.

*Note: If the User Interface, digital input, or Modbus/PROFIBUS command is used to START or STOP Auto-Cal on a transducer, only the first sequence will be triggered.*

Table 11-9: Auto-Calibration setup screen icons for Figure 11-15







Symbol	Function
A	Touch this text box to enter High Span concentration bottle tag / certified value. Figure 11-15 shows 20.900% tag value.
B	Touch this text box to enter High Span concentration tolerance value as a percentage of the High Span value or a fixed value. Figure 11-15 shows $\pm 1.000$ %-vol fixed value.
C	Touch this text box to enter High Span concentration tolerance units as concentration (ppm, mg/m <sup>3</sup> or %-vol) or a percent of the span value (%). Figure 11-15 shows units as %-vol.

Symbol	Function
<b>D</b>	Touch this text box to enter Zero or Low Span concentration bottle tag / certified value. Default is 0.000. Figure 11-15 shows 0.000% value.
<b>E</b>	Touch this text box to enter Zero or Low Span concentration tolerance value as a percentage of the High Span value or a fixed value. Figure 11-15 shows $\pm 1.000$ %-vol fixed value.
<b>F</b>	Touch this text box to enter Zero or Low Span concentration tolerance units as concentration (ppm, mg/m <sup>3</sup> or %-v) or a percent of the span value. Figure 11-15 shows units as %-vol.
<b>G</b>	Touch this text box to enter Time required for Zero gas readings to stabilize, then take an "As Found" reading (see Section 11.8.2 for location of #1, t1, #2). Figure 11-15 shows t1 as 30 seconds.
<b>H</b>	Touch this text box to enter Time required for High Span gas readings to stabilize, then take an "As Found" reading, and Calibrate if reading outside of tolerance (see Section 11.8.2 for location of #3, t2, #4). Figure 11-15 shows t2 as 30 seconds.
<b>I</b>	Touch this text box to enter Time required for Zero gas readings to stabilize, then take an "As Found" reading, and Calibrate if reading outside of tolerance (see Section 11.8.2 for location of #5, t3, #6). Figure 11-15 shows t3 as 30 seconds.
<b>J</b>	Touch this text box to enter Time required for Sample gas readings to stabilize before measurement reporting begins (see Section 11.8.2 for location of #7, t4, #8). Figure 11-15 shows t4 as 30 seconds.
	Symbol where Measurement of Sample begins. Has no function.

Either touch  to run the auto-calibration/validation sequence straight away, or touch  to set a time for the auto-calibration/validation sequence to start.

*Note:* Touch  to abort the auto-calibration/validation set-up sequence. It will also cancel any future events so be careful when using this function.

**Table 11-10: Auto-Calibration setup screen icons for Figure 11-15**

Icon	Meaning	Function
	Calibration settings	Selects the auto-calibration setup screen. Blue background indicates active function as shown in Figure 11-15.
	Validation settings	Selects the auto-validation setup screen.
	Auto-Calibration/ Validation enabled	Forces the current auto-calibration or auto-validation sequence on the screen to be executed.
	Auto-Calibration/ Validation disabled	Disables or cancels the auto-validation or auto-calibration sequence that is in progress. Be careful with this function at it also cancels any future timed events!
	Auto-Calibration/ Validation Timing	Sets up the timing sequences for the auto-calibration and auto-validation. Up to 3 sequences can be set for each.
	Return	Returns the screen to the main Maintenance Menu.

## 11.9 Auto-Cal Thresholds settings per sequence

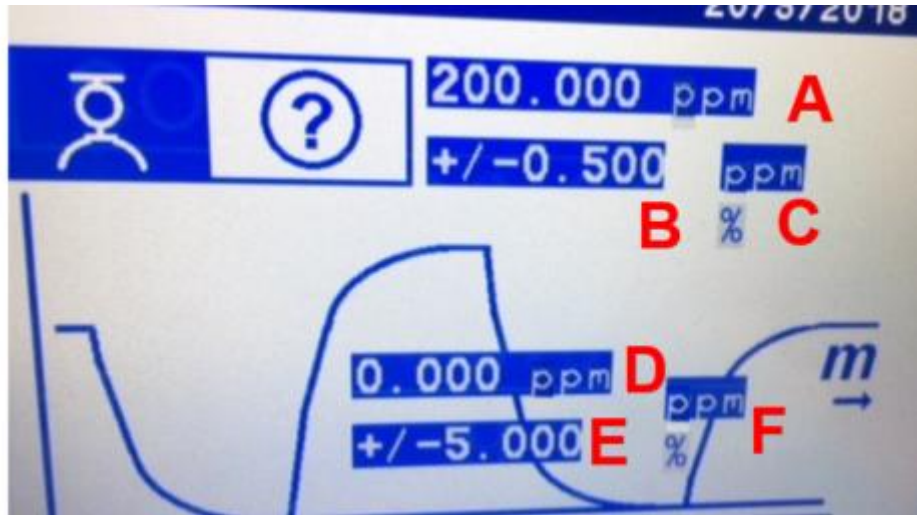
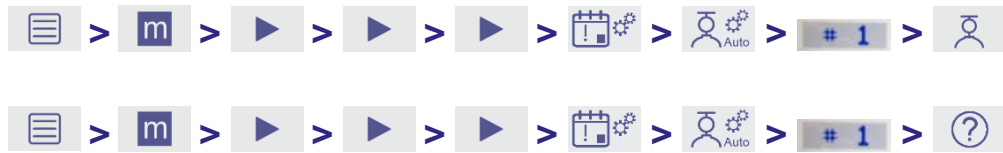

Figure 11-16: Auto-Cal thresholds setup (auto-calibration is active)

Table 11-11: Auto-Cal Threshold settings descriptions (applies to auto-calibration and auto-validation) see Figure 11-16

Symbol	Description
<b>A, D</b>	<p>High Span and Zero Span Bottle Concentration value. The units here can be set at any time from the Measurement Branch but are based upon the intrinsic transducer value.</p> <p>If the Concentration value Units are (%-v) this is the representation of percent concentrations by volume.</p> <p>If the Concentration value Unit is (ppm) this is the representation of part per million by volume concentrations.</p> <p>If the Concentration value Unit is (mg/m<sup>3</sup>) this is the representation of mass concentrations based upon the specific gas component.</p> <p>If the transducer intrinsic value is (%-vol) concentration, then the units will be displayed as %-vol and cannot be changed to any other unit.</p> <p>If the transducer intrinsic value is (ppm) concentration, then the units will be displayed as ppm and can be changed to mg/m<sup>3</sup>.</p>

Symbol	Description
<b>B, E</b>	<p data-bbox="518 275 1398 338">High Span and Zero Span Tolerance Value. The units are set in this screen.</p> <p data-bbox="518 373 1455 468">If the Span or Zero gas value “As Read” is outside of this tolerance, then the auto-validation or auto-calibration will fail and no changes will be made to the transducer calibration.</p> <p data-bbox="518 504 1463 604">If the Span or Zero gas value “As Read” is inside of this tolerance, then the auto-validation passes and auto-calibration recalibrate the transducer equation using the new value.</p>
<b>C, F</b>	<p data-bbox="518 640 1419 703">High Span and Zero Span Tolerance Value Units. The units are set in this screen.</p> <p data-bbox="518 739 1455 802">If the Threshold Value Unit selected is (<b>%-vol</b>) then the value represents a concentration value.</p> <p data-bbox="518 837 1438 932">If the Threshold Value Unit selected is (%) then the value represents a percentage calculation of the concentration value entered regardless of the unit type (<b>%-vol</b>, <b>ppm</b>).</p> <p data-bbox="518 968 1455 1066">If the Threshold Value Units are (<b>ppm</b>) then the value represents a fixed concentration value above and below the Span or Zero concentration in <b>ppm</b>.</p>

## 11.10 Auto-Cal sequence timing setup

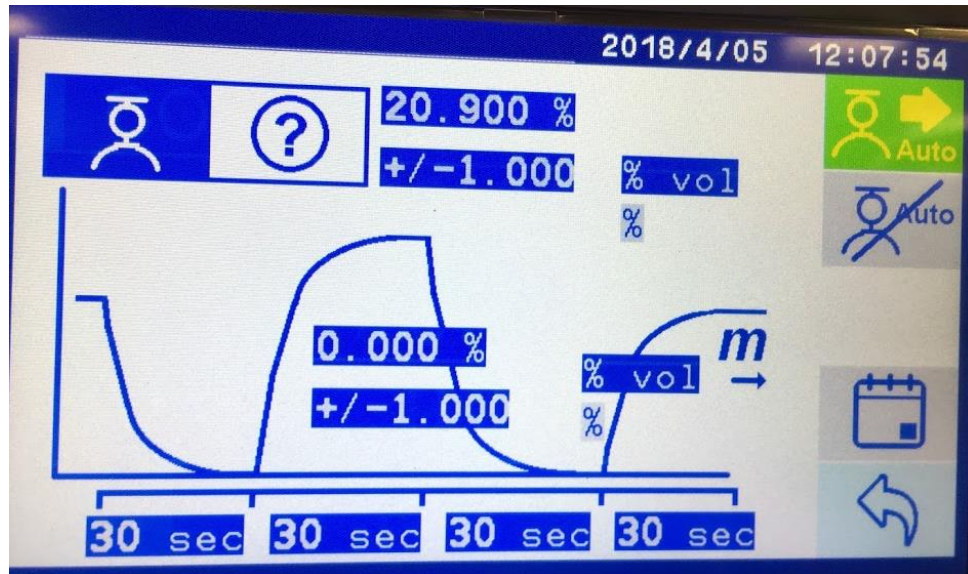
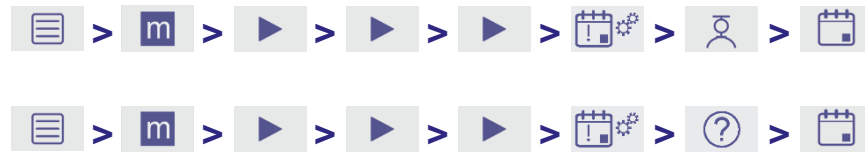





Figure 11-17: Auto-calibration setup screen is active

This section applies to both the auto-calibration and the auto-validation sequences and is used to set up the date, time and repeats for the automatic runs.

### 11.10.1 Auto-Cal sequence general timing



Touch the  icon in Figure 11-17 to get to the Date screen to set the Day/Month/Year for the first auto-calibration / auto-validation event. The first set of arrows allows you to choose to display the values in MM/DD/YY, DD/MM/YY, or YY/MM/DD.

- Touch  to accept entry and move to Time Set screen
- Touch  to cancel the changes and go back to Sequence Setup initial screen



**Figure 11-18: Auto-calibration Date setup screen**

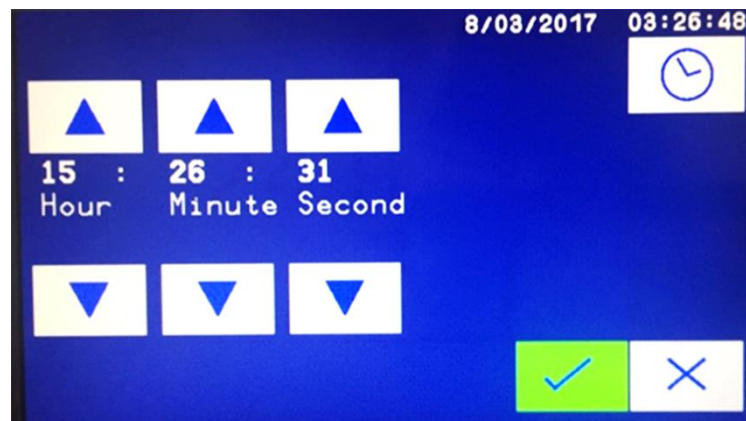

Touch the  icon in Figure 11-18 to accept the Date and take you to the Time screen to set the Hour/Minute/Second for the auto-calibration / auto-validation event.

- Touch  to accept entry and move to Time Set screen
- Touch  to cancel the changes and go back to Sequence Setup initial screen





**Figure 11-19: Auto-calibration Time of Day setup screen**

Touch the  icon in Figure 11-19 to accept the Time and take you to the Repeat Timing screen. This is used to repeat the auto-validation / calibration sequence on a regular basis, every XX Days or every YY Hours.

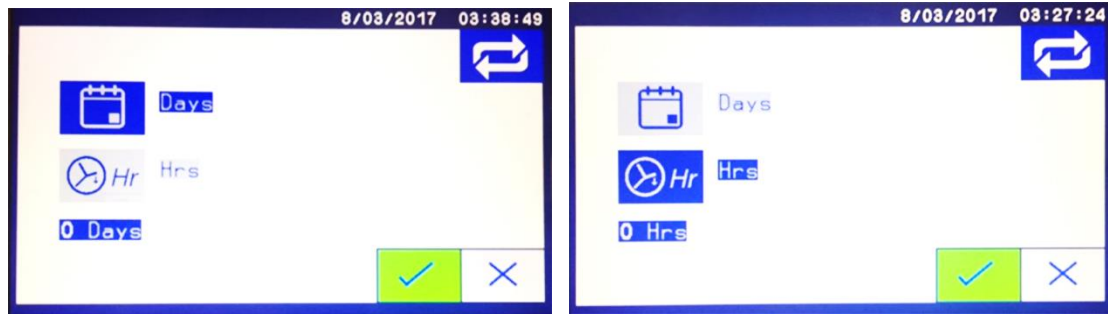
- Touch  to accept entry and move to Repeat Timing screen
- Touch  to cancel the changes and go back to Sequence Setup initial screen



**Figure 11-20: Auto-calibration Repeat Timing setup screen: Left shows repeat Day, Right shows Hour set**

- Touch  to accept entry and move to back to Auto-Cal Main screen
- Touch  to cancel the changes and go back to Sequence Setup initial screen
- Touch  to repeat the auto-calibration.

### 11.10.2 Auto-Cal sequence timing setup for multiple transducers

If you want to run multiple transducers using the same calibration and zero gases, each transducer in the group must use the same settings for the following items:

- For auto-validation  $t_1$ ,  $t_2$ ,  $t_3$  must be the same for all transducers that are to be run at the same time (see Figure 11-11: G, H, I).
- For auto-calibration  $t_1$ ,  $t_2$ ,  $t_3$ ,  $t_4$  must be the same for all transducers that are to be run at the same time (see Figure 11-17: G, H, I, J).
- For auto-validation or auto-calibration all transducer settings for Date (see Figure 11-18), Time (see Figure 11-19), and Repeat Timing (see Figure 11-20) must be the same.

*Note: The  $t_1$ ,  $t_2$ ,  $t_3$ ,  $t_4$  timing should be based upon the gas component that takes the longest time to come to a steady reading.*

## 11.11 Auto-calibration valve installation

The auto-calibration and auto-validation function uses relays to control user provided external valves or single multiport valve, or to send a signal out indicating which gas stream is being used at the time of the trigger. If the auto-calibration option is ordered the analyzer will be equipped with eight relays for each transducer in the analyzer. Relays 6, 7 and 8 for each transducer will be permanently assigned to Zero, Span and Sample respectively. See Section 10.2 for more details.

*Note: It is up to the customer to supply and connect externally powered valves to supply the correct zero and span gas for each transducer. The analyzer switches*



*automatically according to the auto-calibration or auto-validation sequence timing and set up.*

## 11.12 External inputs for Auto-Cal

To activate the Auto-Cal feature (if purchased), connect the Digital Input (DIN) pins DIN 2B and DIN 2C (see Figure 11-21 or Figure 1-2) on Jumper 17 (J17).



**Figure 11-21. Jumper 17 used for Auto-Cal configurations.**

The voltage input is activated by applying (+) 5 – 24 VDC to DIN 1A and (–) 5 – 24 VDC to DIN 1B. The contact closure input is activated by a contact closure created between DIN 1B and DIN 1C.

Details on setting up the various input signals are found in Section 10.7.

## 11.13 Relays used for auto-calibration / validation

- |               |  |
|---------------|--|
| Transducer 1: | <ul style="list-style-type: none"><li>• Zero or Low Gas Relay #6</li><li>• Span (high conc. Calibration gas) Relay #7</li><li>• Sample Gas Relay #8</li></ul>    |
| Transducer 2: | <ul style="list-style-type: none"><li>• Zero or Low Gas Relay #14</li><li>• Span (high conc. Calibration gas) Relay #15</li><li>• Sample Gas Relay #16</li></ul> |
| Transducer 3: | <ul style="list-style-type: none"><li>• Zero or Low Gas Relay #22</li><li>• Span (high conc. Calibration gas) Relay #23</li><li>• Sample Gas Relay #24</li></ul> |
| Transducer 4: | <ul style="list-style-type: none"><li>• Zero or Low Gas Relay #30</li><li>• Span (high conc. Calibration gas) Relay #31</li><li>• Sample Gas Relay #32</li></ul> |

## 11.14 Calibration log file



The analyzer calibration history is saved in the config\_files directory in the CalibrationRecord.txt file. The file can be written to a USB drive inserted into the analyzer using the button sequence shown above. This file can be opened with a program like Microsoft® Excel.

The example in Figure 11-22 shows an auto-calibration and auto-validation entry. The measured process result is reported as the 'Before' or "As Found" value. The entered span value is 25ppm and after calibration the validation result is also 25ppm.

<b>Tx 1 - Before: 25.100000, Cal high (span) to 25.000000 Success. After: 25.000000 - 07/08/17 10:08:20</b>			
<b>DTH current after calibration: 6.635808 uA - 07/08/17 10:08:20</b>			
<b>Tx 1 - Validating to 25.000000 10.000000% - 07/08/17 10:08:31</b>			

Figure 11-22: Example calibration log file

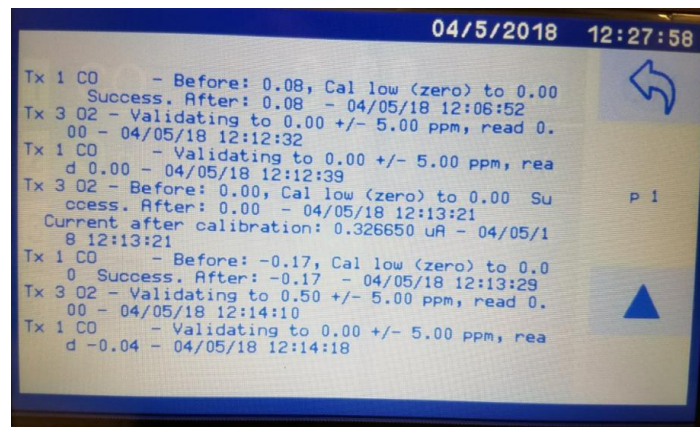

Figure 11-23: Cal log file displayed on screen

Figure 11-23 shows an example of a Calibration Log File as viewed on the analyzer screen. Use the ▲ and ▼ arrow to scroll up or down for more text information on the Auto-Cal operations and results. The information presented here is the same as in the output text log from above.

## 12 Technical specification

---



The protection, accuracy, operation and condition of the equipment may be impaired if the analyzer is not installed in accordance with the requirements of this and other sections of the manual.

### 12.1 Mechanical specification

**Dimensions:**

*(Width x Height x Length)*

**Bench top:** 430 x 140.5 x 544.2 mm  
17 x 5.5 x 21.4 inches

**Rack mount:** 481.5 x 132.5 x 544.2 mm  
19 x 5.2 x 21.4 inches

**Weight:** Main unit: 14kg (30.9 lb.) approx.

### 12.2 Electrical specification

**Electrical supply:**

**Voltage:** 100 to 240 Vac, 50 to 60 Hz  
*(± 10% maximum fluctuation)*

**Supply fuse rating / type:** 6.3 AH / 250V. Size 20 x 5 mm

**Maximum power consumption:** 500 VA

**Interface signal relay ratings** 30 V (dc or ac) / 1A

*Note: The relay output signals are volt-free signals*

**mA output (active):**

Maximum load resistance: 1 kΩ

Isolation voltage (to earth): 500 V (dc or ac)

Output range:

Normal sample measurement: 4 to 20 mA

Fault condition: 0 mA, 2 mA. User selectable

**Voltage output (active):**

Minimum load resistance: 100 kΩ

Isolation voltage (to earth): 250 V (dc or ac)

Output range:

Normal sample measurement: 0 to 10 V

Fault condition: Fault condition selected as an option at the time of purchase.

Under range: Not applicable

**Signal / voltage / mA / RS485 output terminals suitable for:**

Flexible conductors: 0.5 to 1.5 mm<sup>2</sup> (20 to 16 AWG)

Solid conductors: 0.5 to 1.0 mm<sup>2</sup> (20 to 18 AWG)

## 12.3 Maximum voltage ratings

### Common mode compared to chassis ground reference:

Signals:	Maximum voltage rating:
I1+, I1-, I2+, I2-, I3+, I3-, I4+, I4- V1+, V1-, V2+, V2-, V3+, V3-, V4+, V4- IIN1+, IIN1-, IIN2+, IIN2- IIN3+, IIN3-, IIN4+, IIN4- DIN3A, DIN3B, DIN4A, DIN4B J17(ALL)	250 Vac
All relays C, NC, NO	40 Vac
J6 (ALL)	15 Vdc
J8(ALL)	
J18 (ALL)	

### Differential mode between pairs:

Signals:	Maximum voltage rating:
All relays C, NC, NO	30 Vac, dc
IIN1+, IIN- or IIN2+, IIN2- or IIN3+, IIN3- or IIN4+, IIN4-	40 Vdc wrt V1-, V2-, V3-, V4-
DIN3A, DIN3B or DIN4A, DIN4B	24 Vdc
RS485TX+, RS485TX-	15 Vdc
RS485RX+, RS485RX-	15 Vdc
RS232TX, RS232RX	15 Vdc
J17 pin to pin	9 Vdc

## 12.4 Environmental limits

The equipment is suitable for indoor use only.

### Ambient temperature range:

Operation: 5 to 40 °C

Storage: 0 to 50 °C

**Operating ambient pressure range:** 101.3 kPa  $\pm$  10% (1.013 bar  $\pm$  10%)

**Operating ambient humidity range:** 10 to 90% RH, non-condensing

**Operating altitude range:** -500 metres (below sea level) to 2000 metres (above sea level)

**Ingress protection:** IP20



**The auto-ignition temperature of each flammable gas in the sample must be greater than 135 C. The maximum pressure to the analyzer must be limited to 0.75 psig by means of a suitable release system.**

## 13 Routine maintenance

---



The MultiExact 4200 analyzer does not contain any user serviceable parts.



Do not attempt to maintain or service the MultiExact 4200 analyzer unless you are trained and know what you are doing. The analyzer must be maintained by a suitably skilled and competent person.



Do not open or attempt to remove the analyzer cover yourself. If you do, you will invalidate any warranty on the analyzer, and the analyzer may not operate safely or provide accurate measurements.



Sample and calibration gases may be toxic, flammable, or asphyxiant. Never inspect the inlet filter(s), or service or repair the analyzer while such gases are still connected to it.

If the analyzer is to be serviced or repaired, it is important that all pipework is flushed with an inert gas and the analyzer is allowed to freely vent to local atmosphere.

### 13.1 Cleaning the analyzer

When necessary, use a damp (but not wet) cloth to wipe clean the outer surfaces of the analyzer (to prevent the entry of dust or other particulates into the interior of the analyzer).

### 13.2 Routine checks

You only need to carry out simple maintenance procedures annually. Carry out the following regular checks to ensure continuous and safe operation of the monitor.

#### 13.2.1 Inspect / replace the fuse



Ensure that the electrical supply is isolated / locked-out from the analyzer. If you do not, there will be a danger of injury or death from electric shock.



**Fire Hazard: Only use the same type and rated fuse as recommended.**

If you think that an electrical supply fuse has failed, use the following procedure to inspect the fuses and replace them if necessary:

1. Open the fuse panel on the rear of the analyzer (Figure 13-1). To do this, carefully insert a small screwdriver into the gap on the right of the panel and press the clip to open the panel.

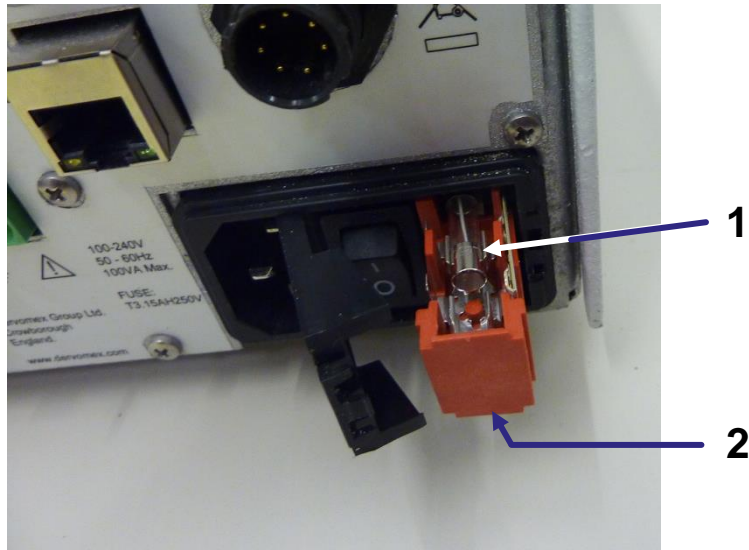

**Figure 13-1: Open the fuse panel**



**Figure 13-2: Fuse panel opened**

2. Pull the red fuse holder out of the panel (Figure 13-2).  
Both live and neutral lines have fuse protection. The neutral fuse is shown (1 in Figure 13-3); the live fuse is located in the underside of the red fuse holder (2 in Figure 13-3).



**Figure 13-3: Pull out the red fuse holder**

3. Remove the top (neutral) fuse from the holder and check the continuity across the fuse.

If there is continuity, the fuse has not failed, so refit it into the fuse holder.

If there is no continuity, fit a new fuse into the fuse holder.



**Make sure the fuses are the correct type and rating. The fuse type and rating is shown on the rear panel to the left of the mains connector.**



**Make sure you fit the fuse in the correct position in the fuse holder as shown in (Figure 13-3).**

4. Repeat step 3 for the bottom (live) fuse which is located on the underside of the red fuse holder.
5. Push the fuse holder back into the fuse panel and close the panel door. It will click into place.

### 13.3 Preventative maintenance

To minimize unscheduled analyzer downtime, ensure the proper operation of the analyzer and to comply with the guidelines of applicable regulatory bodies, we recommend that you utilize an annual preventative maintenance program for your analyzer.



**If toxic and/or flammable samples are being analyzed it is essential to check the analyzer and associated sample lines/system for leaks (every 6 months). MAX pressure that may be applied to each module is 0.75 psig, however this must be applied and removed slowly to both the inlet and outlet simultaneously to avoid damage to the measuring sensors.**



The preventative maintenance program consists of an annual inspection of the analyzer, and repair of any faults, to ensure that the analyzer meets its original factory specification.

Contact Servomex or your local Servomex agent to arrange for a preventative maintenance contract.

## 14 Troubleshooting

---

The following section will help to resolve many of the common operational situations that occur with the analyser. Try the possible remedies in the order listed.

### 14.1 Error codes

The following codes may be displayed in the event of a problem or error. The table gives a suitable remedy.

<b>Code</b>	<b>Meaning</b>	<b>Possible remedy</b>
B: Bad command	Internal Software Error	Power Cycle
C: Comms fault	Data not received from transducer	Check transducer cable
D: Data fault	Data not received from transducer	Check transducer cable
E: Out of spec	The reading exceeds the maximum range	Check plumbing
S: Calibrating	Calibrating Failed	Recalibrate, Check Bottle concentration value
T: Overtemp	Transducer temperature is over range	Reduce ambient temperature
X: Electronics fault	Critical Electrical Fault	Contact Servomex

### 14.2 Jam conditions

See section 10.1 "Configure and use the mA outputs."

# 15 Storage and disposal

---

## 15.1 Storage

Refit any protective plastic covers and place the analyzer and any associated equipment in its original packaging before storage. Alternatively, seal it inside a waterproof plastic bag, sack, or storage box.

Store the analyzer and any associated equipment in a clean, dry area. Do not subject it to excessively hot, cold, or humid conditions.

## 15.2 Disposal

Dispose of the analyzer and any associated equipment safely, and in accordance with all of your local and national safety and environmental requirements.

**Hint:** *If you send the analyzer to Servomex or your local Servomex agent for disposal, it must be accompanied by a correctly completed decontamination certificate and a Return Authorization Number (RAN) (17.1Appendix E).*

### 15.2.1 Disposal in accordance with the Waste Electrical and Electronic Equipment (WEEE) Directive

The label shown in Figure 15-1 is fitted to the analyzer.



**Figure 15-1: The WEEE label**

This label identifies that:

- The analyzer is considered to be within the scope of the Waste Electrical and Electronic Equipment (WEEE).
- The analyzer is not intended for disposal in a municipal waste stream (such as landfill sites, domestic recycling centers and so on), but must be submitted for material recovery and recycling in accordance with the local regulations which implement the WEEE Directive.

For additional information and advice on the disposal of the analyzer in accordance with the requirements of the WEEE Directive, contact Servomex or your local Servomex agent.

## 16 Spares



Do not use spares other than those specified below, and do not attempt to carry out any maintenance procedures other than those specified in this manual. If you do, you can damage the analyzer and invalidate any warranty.

The standard spares available for the analyzer are shown below. You can order these spares from Servomex or your Servomex agent.

**Table 16-1: MultiExact 4200 Spares List**

<b>Part number</b>	<b>Description</b>
<b>089000KITA</b>	<b>4900 Multigas One Year Service Kit contains: (same spare for both ME4200 and 4900MG)</b>
	Filter Element, Fan
	External Stainless-Steel Filter Kit
	Fuse Kit
	Back Panel Connector Set
	Main Fuse
<b>089000KITB</b>	<b>4900 Multigas Two Year Service Kit contains: (same spare for both ME4200 and 4900MG)</b>
	Filter Element, Fan
	External Stainless-Steel Filter Kit
	Fuse Kit
	Back Panel Connector Set
	Main Fuse
<b>S223752</b>	<b>Power supply 24V – ME4200</b>
<b>S223753</b>	<b>Power supply 12V – ME4200</b>
<b>S8200901</b>	<b>Zener Barrier PCBA – ME4200</b>

**Table 16-2: MultiExact 4200 Transducer Spares**

<b>Gas Molecule</b>	<b>Range</b>	<b>Transducer Spare PN</b>
O <sub>2</sub>	0 - 25%	05200941
CO <sub>2</sub>	0 - 100%	01520701
	0 - 50%	01520702
	0 - 25%	01520703
	0 - 10%	01520704
	0 - 5%	01520705
	0 - 2.5%	01520706
	0 - 1.0%	01520707
	0 - 5000 ppm	01520708
	0 - 2500 ppm	01520709
	0 - 5 / 0 - 100 ppm	SD1210731
CO	0 - 100%	01522701
	0 - 50%	01522702
	0 - 25%	01522703
	0 - 10%	01522704
	0 - 2.5%	01520706
	0 - 1.0%	01522707
	0 - 50 / 0 - 500 ppm	SD1210701
N <sub>2</sub> O	0 - 50 / 0 - 500 ppm	SD1210741

<b>Gas Molecule</b>	<b>Range</b>	<b>Transducer Spare PN</b>
CH <sub>4</sub>	0 – 100%	01521701
	0 – 50%	01521702
	0 – 25%	01521703
	0 – 5%	01521705
	0 - 50 / 0 - 500 ppm	SD1210751

## 17 Warranty

---

Servomex instruments are warranted to be free from defects in workmanship and materials. Liability under this warranty is limited to servicing, calibrating, and replacing any defective parts of the instrument returned to an authorized Servomex Service Center for that purpose. Fuses are specifically excluded from any liability.

This warranty is effective from the date of delivery to the original purchaser. The equipment must be determined by Servomex to have been defective for the warranty to be valid.

This warranty applies as follows:

- one year for electronics
- one year for mechanical failures to the transducer

If damage is determined to have been caused by misuse or abnormal conditions of operation, the owner will be notified, and repairs will be billed at standard rates after approval.

Servomex Group Limited warrants each instrument manufactured by them to be free from defects in material and workmanship at the F.O.B. point specified in the order, its liability under this warranty being limited to repairing or replacing, at the Seller's option, items which are returned to it prepaid within one year from delivery to the carrier and found, to the Seller's satisfaction, to have been so defective.

In no event shall the Seller be liable for consequential damages. NO PRODUCT IS WARRANTED AS BEING FIT FOR A PARTICULAR PURPOSE AND THERE IS NO WARRANTY OF MERCHANTABILITY.

Additionally, this warranty applies only if: (i) the items are used solely under the operating conditions and in the manner recommended in the Seller's instruction manual, specifications, or other literature; (ii) the items have not been misused or abused in any manner or repairs attempted thereon; (iii) written notice of the failure within the warranty period is forwarded to the Seller and the directions received for properly identifying items returned under warranty are followed; and (iv) with return, notice authorizes the Seller to examine and disassemble returned products to the extent the Seller deems necessary to ascertain the cause of failure. The warranties stated herein are exclusive. THERE ARE NO OTHER WARRANTIES, EITHER EXPRESSED OR IMPLIED, BEYOND THOSE SET FORTH HEREIN, and the Seller does not assume any other obligation or liability in connection with the sale or use of said products.

## 17.1 Maintenance policy

In cases when equipment fault is suspected, please notify your representative of the problem and provide them with model and serial numbers.

If the problem cannot be resolved, then ask for a Return Product Authorization Number (RPA in North America and RAN Rest of World) and shipping instructions. The issue of an RPA/RAN does not automatically imply that the equipment is covered by our warranty - that will be determined after we receive the equipment.

Pack the equipment in a suitable box with sufficient padding, include the RPA number on your paperwork, and send the equipment, prepaid, to the designated address. Servomex will not accept equipment returned without an RPA/RAN, or with reversed shipping or import/export charges.

If the warranty has expired, or the damage is due to improper use or exposure of the equipment, Servomex will provide an estimate and wait for approval before commencing repairs.

For your convenience a Return Product Authorization Request Form is provided in Appendix E. Fill out the form and sent it back to Servomex to obtain an RPA/RAN.



# Appendix A Compliance and standards

---

## A.1 Applicable EU Directives

Low Voltage Directive: 2014/35/EU

Electromagnetic Compatibility (EMC) Directive: 2014/30/EU

## A.2 Applicable standards

EN 61010-1:2010

EN 61326-1:2013 / IEC 61326-1:2012

EN15267-3:2007 MCERTS Performance Standards for CEMS

EN 14181: 2014 for QAL1

# Appendix B Optional RS485 / RS232

## B.1 Serial Communication introduction

The MultiExact 4200 offers the option for RS232 or RS485 serial communications. If RS232 is purchased, the connection is via the 9-pin D-type RS-232 serial connector on the back plane (Figure B-1). If RS485 is purchased, the connection is via the RS-485 connector on the back plane (Figure B-1).



**Make sure that the electrical installation of any equipment connected to the analyzer conforms with all applicable local and national electrical safety requirements.**



**The RS232 output is separated from the analyzer mains circuits by reinforced insulation. The terminals must only be connected to circuits that are themselves separated from mains voltages by at least reinforced insulation.**



**To comply with EMC requirements, you must use a shielded cable to connect to the RS232 output. The shield must also be connected to the analyzer enclosure at Earth / ground.**

## B.2 Connections

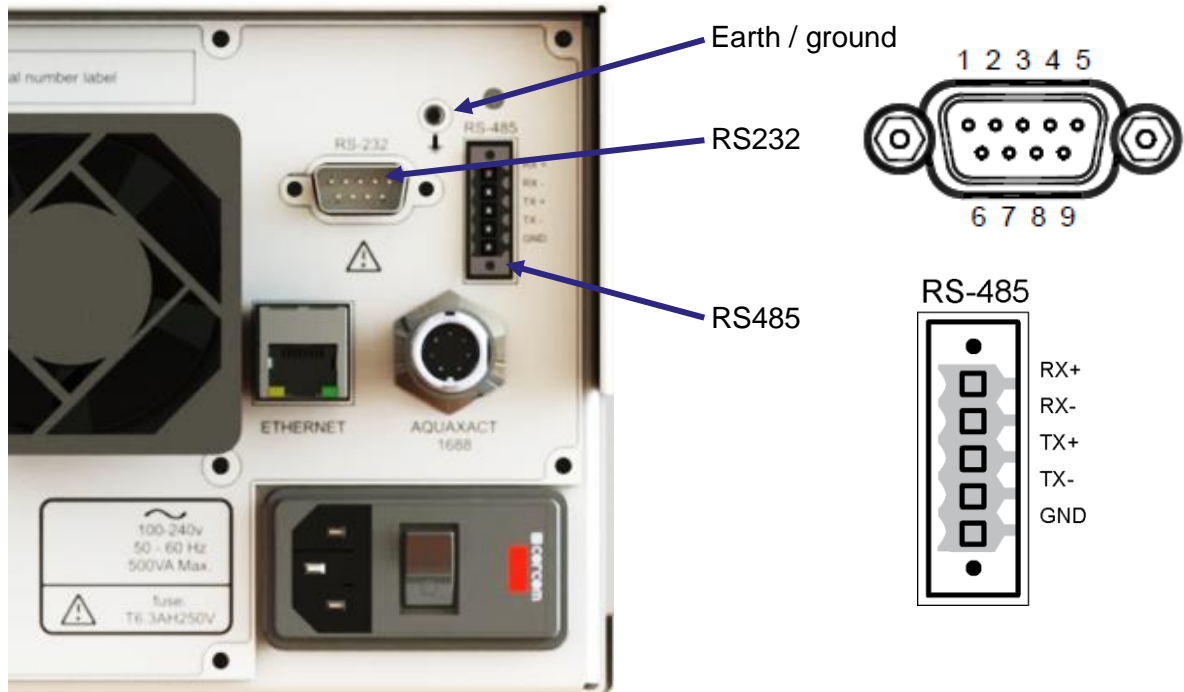

Figure B-1: Rear panel of the analyzer showing RS232 and RS485 connectors

### B.3 Serial set up parameters

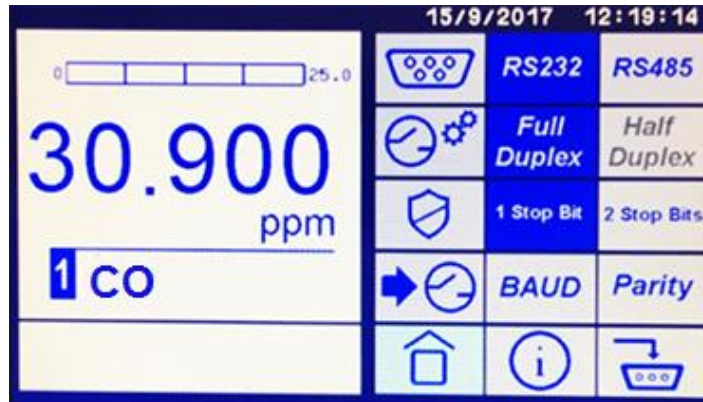

Figure B-2: Serial parameter setup page

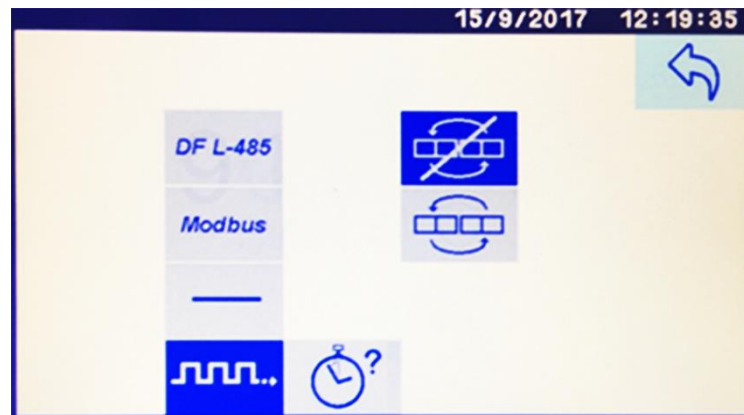

















Figure B-3: Serial parameter page 2

The Serial parameter icons are listed below:

Icon	Meaning	Function
	RS232 communications	To select RS232.
	RS485 communications	To select RS485.
	Full Duplex	To select full duplex.
	Half Duplex	To select half duplex.
	1 stop bit	To set 1 stop bit.
	2 stop bits	To set 2 stop bits.
	Baud rate	To set the baud rate.
	Parity	To set the parity.
	RS485 function	To assign RS485 function. A second screen (Figure B-3) displays the following functions:
	RS485 function: DF communications	To assign RS485 function to legacy DF communications.
	RS485 function: Modbus	To assign RS485 function to Modbus (Appendix C).
	RS485 function: None	No RS485 function.
	RS485 function: periodic stream	To assign a periodic stream of measurement results of all transducers.
	RS485 function: output frequency setup	To set the intervals for the output frequency (in seconds) via a numerical entry screen.
	RS485 – Modbus: Word swapping on	To switch on Modbus word swapping.
	RS485 – Modbus: Word swapping off	To switch off Modbus word swapping.

## B.4 Streaming RS232 output

In continuous mode, a data frame is transmitted by the serial output port at a user-defined interval. The format of the data frame is given in the following tables; however, it is a list of process variables (fields) preceded by a start character, separated by semi-colons and terminated by carriage return and line feed, i.e. A;B;C;D;E;F;.....;N;<CR><LF>

The frame frequency and generic communications parameters are configured in the analyser software. The frame frequency sets up the frequency of transmission of the data frame down the serial communications port. For example, if the value is set to 15 seconds, then the output data frame will be transmitted once every 15 seconds. The frequency is set in steps of one second from 1 to 9999 seconds. If the value is set to zero, the transmission of data down the serial port stops and will not restart until a non-zero value is entered.

**Table B-1: Serial output data frame, start, measurement and end sequences**

Field	Number of characters	Function	Entry/format
A	8	Date	<b>DD-MM-YY</b>
B	8	Time	<b>HH:MM:SS</b>
C	2	Analyzer failure and maintenance fault status	1 <sup>st</sup> character: <b>F</b> for failure 2 <sup>nd</sup> character: <b>M</b> for maintenance (Spaces = OK)
D	8	Auto-calibration flags: 2 characters for each of the 4 calibration groups	1 <sup>st</sup> character: Group 1, <b>S</b> for sample, <b>C</b> for calibration gas 2 <sup>nd</sup> character: Group 1, <b>1</b> for cal gas 1, <b>2</b> for cal gas 2 Repeat for groups 2, 3 and 4
E	2	Number of process measurements or variables	<b>03 to 07</b> . The following fields will be repeated for each transducer and any derived measurements. The last two variables will always be the two external inputs E1, E2

	<b>Field</b>	<b>Number of characters</b>	<b>Function</b>	<b>Entry/format</b>
Measurement sequences (see note below)	F	2	Measurement identity	e.g. <b>I1, D1, E1</b>
	G	6	Measurement name	e.g. <b>Oxygen</b>
	H	6	Value	e.g. <b>20.9</b>
	I	3	Units	e.g. <b>%</b>
	J	4	Alarms	One character for each alarm. <b>1, 2, 3, 4</b> raised = alarm Space = OK
	K	2	Failure and maintenance fault status	1 <sup>st</sup> character: <b>F</b> for failure 2 <sup>nd</sup> character: <b>M</b> for maintenance (Spaces = OK)
	L	1	Calibration status	<b>C</b> in calibration, or space
	M	1	Warming up status	<b>W</b> in warming up, or space
	N	4	Checksum	e.g. <b>096A</b>
	-	-	End code: <CR> and <LF>	ASCII code 13 and 10

*Note: Fields F-M are repeated for each measurement (including derived) concluding with external inputs E1 and E2, before returning to the end sequence of N and the end codes.*

# Appendix C Implementation guide for Modbus communications

---

## C.1 Introduction

This appendix details the implementation and use of the Modbus protocol in the MultiExact 4200 analyzer.

## C.2 References

Document "MODBUS over Serial Line Specification & Implementation guide V1.0 Nov 02" located on Modbus web site modbus.org.

## C.3 Modbus setup

The Modbus setup form will allow the user to configure the following parameters:

Default values are in **Bold**.

Parameter	Options	Comments
Address	1 to <b>247</b>	Slave address of unit.
Mode	ASCII or <b>RTU</b>	Select serial transmission mode.
Baud rate	2400, 4800, 9600, <b>19200</b> , 38400	
Parity	Odd, <b>Even</b> , None	

## C.4 Supported function codes

For simplicity, only the following function codes will be supported:

Function	Description	Usage
01	Read coils	Read calibration status, pump state, etc.
02	Read discrete inputs	Read faults and alarm states.
03	Read holding registers	Read settings.
04	Read input registers	Read measurements, units, etc.

Function	Description	Usage
05	Write single coil	Change modes, perform calibration etc.
06	Write single register	Change single setting.
16	Write multiple registers	Change multiple settings.

## C.5 Exception codes

If an error occurs while processing a message one of the following exception codes will be returned by the instrument:

Code	Condition	Meaning
01	Illegal function	Requested function code is not supported.
02	Illegal data address	The combination of data address and transfer length is invalid for this function.
03	Illegal data value	A value contained in the query data field is not an allowable value. This indicates a fault in the structure of the remainder of a complex request. This does NOT mean that a value to be stored in a register is incorrect as Modbus has no means of determining what is legal for any particular register.
04	Slave device failure	An unrecoverable error occurred while the unit was attempting to perform the requested action.

## C.6 Addressing

Addresses in Modbus ADU (application data unit), run from 1 – N, whereas addresses in the Modbus PDU (protocol data unit) run from 0 – N. This appendix gives addresses in the ADU model. Depending on the particular Modbus master, addresses may have to be entered as they are given or have 1 subtracted from them. For example, to read register 101 an address of 100 may be needed.

## C.7 Floating point numbers

Floating point numbers (e.g. 12.34, –1012.32, etc.), are digitally represented using the IEEE–754 format. Single precision floating point numbers are used throughout and they



require 32 bits of data. Since a Modbus register holds 16 bits it takes 2 registers to represent a floating-point number. We default to having the most significant word of the float, bits 16 – 31, in the first register, and the least significant word, bits 0 – 15, in the next register.

## C.8 System data

Base Address	Block	Base Address Offset	Parameter	Supports Function Code										
				1	2	3	4	5	6	8	16			
3001	0	0-9	Instrument Serial Number			✓								
		10-19	Analyzer Firmware			✓								
3021	1	0-9	Supervisor Password			✓								
		10-19	Operator Password			✓								
3041	2	0-9	Option Board Digital Firmware			✓								
		10-19	Option Board Analog Firmware			✓								
3061	3	0-9	Reserved			✓								
		10-19	Bootloader Firmware			✓								
3981	49	0	NumberOfInternalTransducers			✓								
		1	NumberOfExternalTransducers			✓								
		2	NumberOfTransducers			✓								
		3	NumberOfMeasurements			✓								
		4	NumberOfAins			✓								
		5	NumberOfAouts			✓								
		6	NumberOfAlarms			✓								
		7	NumberOfRelays			✓								
		8	NumberOfDins			✓								
		9	Number of legacy pressure devices			✓								
		10	Number of legacy flow alarms			✓								
11	Number of Legacy Heaters			✓										

Base Address	Block	Base Address Offset	Parameter	Supports Function Code									
				1	2	3	4	5	6	8	16		
		12	Number of Legacy Sample Heater			✓							
		13	Number of Field Buses			✓							
		14	Number Of Ovens			✓							
		15	Number Of Network Cards			✓							
		16	NumberOfResources			✓							

## C.9 System Settings

Base Address	Block	Base Address Offset	Parameter	Supports Function Code									
				1	2	3	4	5	6	8	16		
2001	0	0	Floating point order	✓				✓					
		1	User interface busy	✓									
		2	Disable user interface	✓				✓					
		3	Audible alarm	✓				✓					
		4	ResponseDelay			✓				✓			✓
		5	Language			✓				✓			✓
		6	Date format			✓				✓			✓
		7	Decimal format			✓				✓			✓
		8	Backlight Time			✓				✓			✓
		9	clock: Hrs			✓				✓			✓
		10	clock: Mins			✓				✓			✓
		11	clock: Seconds			✓				✓			✓
		12	date: Year			✓				✓			✓
		13	date: Month			✓				✓			✓

Base Address	Block	Base Address Offset	Parameter	Supports Function Code								
				1	2	3	4	5	6	8	16	
		14	date: Day			✓				✓		✓

## C.10 System Control

Base Address	Block	Base Address Offset	Parameter	Supports Function Code								
				1	2	3	4	5	6	8	16	
1	0	0	Service in Progress							✓		✓

0=Not In Service Mode, 1=Service Mode.

Instrument MUST be set to Service in Progress before any calibration or override actions are performed.

## C.11 Measurements

Base Address	Block	Base Address Offset	Parameter	Supports Function Code			
				1	2	3	4
1001	0	0	Number Of Measurements			✓	
	0	1	Repeat (safeguard)			✓	
	0-49	2(n-1) + 2	Measurement n			✓	

## C.12 Transducer calibration data

Data for transducer n are found at below address + 20 (n-1) for n=1 to n=4.

Base Address	First Block Number	Block	Base Address Offset	Parameter	Supports Function Code							
					1	2	3	4	5	6	8	16
4721	0	Tx (n)	0	AutovalState			✓					
			1	AutovalGas			✓					

Base Address	First Block Number	Block	Base Address Offset	Parameter	Supports Function Code								
					1	2	3	4	5	6	8	16	
			2	AVFinishing			✓						
			3	AVFailState			✓						
			4	Number of Cal / Val Points			✓						
			5	Select Cal/val point			✓			✓			✓
			6	LastCal/val Point n Reading			✓						
			8	LastCalPoint n Target			✓						
			10	LastCalPoint n Delta			✓						
			12	Last Cal point n Time			✓						
			13	Last Cal point n Date			✓						
			15	Cal point passed/failed			✓						

AVFinishing 0=Not Finishing, 1=Finishing

AVFailState 0=Not in Fail State, 1=In Fail State

Select Cal/val point 0=zero 1=span; This must be written to read corresponding values for last reading, target, delta. Delta is expressed as floating-point proportion ((target-last reading)/target).

### C.13 Transducer live info

Data for transducer n are located at ((below address) + 80(n-1)).

Base Address	First Block Number	Block	Base Address Offset	Parameter	Supports Function Code								
					1	2	3	4	5	6	8	16	
4161	0	Tx (4n-1)	0	Transducer Type			✓						
			1	Tag Number			✓						
			2	Name			✓						
			11	Measurement			✓						

Base Address	First Block Number	Block	Base Address Offset	Parameter	Supports Function Code											
					1	2	3	4	5	6	8	16				
			13	Pressure Compensated Measurement			✓									
			15	Filtered Measurement			✓									
			17	Transducer temperature			✓									
4181	1	Tx (4n)	0	Alarm Active	✓											
			1	Fault	✓											
			2	Service in progress	✓											
			3	Out of Specification	✓											
			4	Maintenance required	✓											
			5	Transducer maintenance fault	✓											
			6	Transducer error	✓											
			7	Transducer fatal fault	✓											
			8	WarmingOn	✓											
			9	Reserved	✓											
			10	Reserved	✓											
			11	Calibration fault	✓											
			12	Communication fail	✓											
			13	Transducer not detected	✓											
			14	Autoval / cal failed	✓											
			15	Remote calibration/val denied	✓											
4201	2	Tx (4n+1)	0	Heartbeat toggling at 1 Hz	✓											
			1	Remote service in progress	✓											

Base Address	First Block Number	Block	Base Address Offset	Parameter	Supports Function Code										
					1	2	3	4	5	6	8	16			
			2	Transducer calibration mode	✓										
			3	Auto validation/ calibration	✓										
			4	Incorrect transducer type	✓										

## C.14 Transducer settings

Data for transducer n are located at ((address below) + 20(n-1)).

Base Address	First Block Number	Block	Base Address Offset	Parameter	Supports Function Code										
					1	2	3	4	5	6	8	16			
4481	0	Tx (n)	0	Name			✓								
			9	Units			✓								
4561	4		0	Reserved			✓			✓			✓		
			2	Reserved			✓			✓			✓		
			4	Unit selection (scaling Factor)			✓			✓			✓		
			6	PMR			✓								
			8	Cross Interference correction/			✓			✓			✓		
			10	Reserved											

## C.15 Relay control

Relay n data is found at ((address below + 20(n-1)) for n=1 to n=32

Base Address	First Block Number	Block	Base Address Offset	Parameter	Supports Function Code							
					1	2	3	4	5	6	8	16
9081	0	Relay (n)	0	Active State			✓			✓		✓
			1	Override State			✓			✓		✓
			2	Override			✓			✓		✓
			3-19	Reserved								
9721	32	Relay (n)	0-19	Reserved								

## C.16 Resource live info

Base Address	First Block Number	Block	Base Address Offset	Parameter	Supports Function Code							
					1	2	3	4	5	6	8	16
8741	0	0	0	Chassis temperature	✓			✓				

## C.17 Resource settings

Data for transducer n are located at below address + 18(n-1).

Base Address	First Block Number	Block	Base Address Offset	Parameter	Supports Function Code							
					1	2	3	4	5	6	8	16
8765				Minimum measurement	✓			✓				
8773				Range change point	✓			✓				

## C.18 Transducer control

Data for transducer n are found at the below addresses + 40(n-1).

Base Address	Block	Base Address Offset	Parameter	Supports Function Code									
				1	2	3	4	5	6	8	16		
4001	0	0	Calibration mode on/off	✓					✓				
		1	Start auto val						✓				
		2	Stop auto val						✓				
		3	Capture and enable baseline subtraction	✓					✓				
4021	1	0	reserved										
		1	Summary of alarm and relay states: Reports a bit field of the alarm states in low byte and the relay states in high byte for the designated Tx						✓				
		2	Calibration gas in use: 0=Sample Gas 1, 1=Sample Gas 2, ...						✓		✓		✓



# Appendix D PROFIBUS

---

This appendix contains installation and operation instructions and data tables available with the PROFIBUS option.

## D.1 Safety



**Read the rest of this manual carefully before you use this appendix.**

## D.2 Description

The PROFIBUS option adds DPv0 synchronous and DPv1 asynchronous communication capabilities to the **MultiExact 4200** Analyzer. The PROFIBUS option board provides the following features:

- Supports DPv0/DPv1 PROFIBUS communication with RS485 transmission
- DPv1 communications with class I and class II Master devices
- Separate DPv0 modules to optimize bus load
- Profibus Address can be set from the User Interface

## D.3 Electrical installation



**Follow the PROFIBUS Installation Guidelines when connecting the PROFIBUS.**

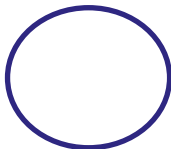

**Figure 17-1: PROFIBUS connection on rear of the analyzer**



**There are no internal termination resistors; if the device is at the end of the segment, termination resistors should be on the connector or the segment should have an active termination unit.**

1. Use recommended PROFIBUS cable, optimized for RS485 transmission.
2. Standard PROFIBUS 9-pin sub-D connector is used for PROFIBUS, the connector is labelled as “PROFIBUS” on the back of the analyzer.

PROFIBUS connector (Comms 1)		
Pin No	Signal	Definition
3	TxD-P	Data line plus (B-Line)
4	RTS	PROFIBUS Ready To Send signal
5	DGND	Data Ground
6	VP	+5V supply for terminating resistors
8	TxD-N	Data line minus (A-Line)
Case	Shield	Ground Connection

- To ensure correct operation follow the PROFIBUS Installation Guidelines. For information on the PROFIBUS installation guidelines, refer to [www.profibus.com](http://www.profibus.com).

## D.4 PROFIBUS settings

### D.4.1 Confirming PROFIBUS availability

If the analyzer was ordered with the PROFIBUS option, the PROFIBUS connector will be populated and its presence confirms the unit is configured for serial comms via PROFIBUS.

### D.4.2 Setting the PROFIBUS address

The default PROFIBUS address for the analyser is set to 126.

Press the following icon sequence to change the PROFIBUS address of the analyser.



After changing the address, turn the unit off and on again for it to respond to the new address.

### D.4.3 Monitoring Profibus line Status

The user interface provides information on the PROFIBUS line status. There are three reports available:

Wait for parameterization: There are no communications between the analyser and the PROFIBUS master device.

Wait for configuration: Initial parameterization message received, waiting for configuration data from the PROFIBUS master.

Data exchange: The analyser and the PROFIBUS master device are communicating, using DPv0 cyclic messages.

## D.5 PROFIBUS DPV0 features

### D.5.1 DPv0 modules

The synchronous messaging structure of the DPv0 network requires all variables to be repeated in every message. This means the PLC has to be programmed to parse incoming and outgoing messages to extract required data. These protocol limitations mean that only frequently required parameters, which are important to be remotely accessible, are made available for DPv0 access.

The MultiExact 4200 is capable to operate with different module configurations enabling the user to optimize network traffic. For example, if detailed status information is not required, the user can choose to omit the Measurement Status modules in the configuration.

The analyzer can support up to 8 modules, and the user can choose to include these modules in any order. The PROFIBUS master can configure the MultiExact 4200 to include the following modules:

Module name	Type	Size
Measurement 1	Input and Output	6 Input, 6 Output Bytes
Measurement 2	Input and Output	6 Input, 6 Output Bytes
Measurement 3	Input and Output	6 Input, 6 Output Bytes
Measurement 4	Input and Output	6 Input, 6 Output Bytes
Measurement 1 Status	Input	6 Input Bytes
Measurement 2 Status	Input	6 Input Bytes
Measurement 3 Status	Input	6 Input Bytes
Measurement 4 Status	Input	6 Input Bytes

Example Configuration 1:

Slot	Module	Input byte data offset	Output byte data offset
1	Measurement One	0	0

Slot	Module	Input byte data offset	Output byte data offset
2	Measurement One Status	6	6
3	Measurement Two	12	12

Example Configuration 2:

Slot	Module	Input byte data offset	Output byte data offset
1	Measurement Three	0	0
2	Measurement One	6	6
3	Measurement One Status	12	-
4	Measurement Two	18	12
5	Measurement Two Status	24	-

## D.5.2 PROFIBUS master device configuration

Refer to your PROFIBUS master device's operator manual to configure DPv0 communications with the **MultiExact 4200**.

8000F77.gsd can be used as the GSD file to configure the master device. This is available on request from your Servomex representative.

### Data format

**Endianness:** All data transfers are word aligned, and the analyzer uses Big-Endian order, as specified in PROFIBUS standards. In Big-Endian order, the Most Significant Byte (HI) comes before the Least Significant Byte (LOW). Bit order follows the same rule and bit 0, is the least significant bit.

**Floating Point Numbers:** All floating point numbers (e.g. 12.34, -1012.32, etc.), are digitally represented using the IEEE-754 format. Single precision floating point numbers are used throughout and since they require 32 bits of data, they occupy 2 words. The most significant word is transferred first.

**Low/Hi Byte:** The LOW byte of a word is the least significant byte. The Most significant Byte is called the HIGH Byte.

### Measurement module data map

Measurement modules contain measurement data related to the measurement modules. All four module mappings are the same.

PROFIBUS DPv0 inputs			
Word	# Word	R/W	Name
0	2	R	Measurement as seen on the measurement display. 32 -bit Floating point data in IEEE-754 format.
2	1	R	Status Word (See Below)

Measurement status word			
Byte	Bit	Name	Definition
LO	0	Warming State	0= Not warming, 1= Warming.
	1	Heater Fault	0=normal, 1=fault
	2	Sample Heater Fault	0=normal, 1=fault
	3	Calibration Fault	0=normal, 1=fault
	4	Communication alarm	0=normal, 1=fault
	5	Transducer not detected	0=transducer detected, 1=transducer not detected
	6	Autoval/cal failed	An autocal or autoval operation has failed to complete
	7	Remote calibration/val denied	0=normal, 1=A remote request for calibration or validation has been denied
HI	0	Alarm	0=normal, 1=alarm active
	1	Fault	0=normal, 1=fault
	2	Service in Progress	0=normal, 1=service in progress
	3	Out of Specification	0=normal, 1=out of specification
	4	Maintenance Required	0=normal, 1=maintenance required
	5	Transducer maintenance fault	0=normal, 1=transducer maintenance fault
	6	Transducer error	0=normal, 1=Transducer is indicating an error code
	7	Transducer fatal fault	0=normal, 1=Transducer has identified a condition requiring return for service

PROFIBUS DPv0 outputs				
Word	Byte	Bit	Read/Write	Name
0	LOW	0-7	Write	Reserved
	HI	0	Write	Calibration mode on/off (Tx control)
		1	Write	Start auto validation (Tx control)
		2	Write	Stop auto validation
		3	Write	Enable baseline subtraction
1			Write	Invoke calibration n
2			Write	Sample Gas Selection n

### Measurement status data map

Measurement Status modules, contains status related to measurements. All four module mappings are the same.

PROFIBUS DPv0 inputs			
Word offset	# Words	Read/Write	Name
0	1	Read	Calibration and Validation Word (see below)
1	1	Read	Bitfield of alarm states in low byte, relay states in high byte. Bit 0 - alarm or relay 1, bit 1 – alarm or relay 2, etc.)
2	1	Read	System heartbeat in bit 0, toggles at 1Hz

Calibration and validation status word			
Byte	Bit	Name	Definition
LOW	0-2	Auto Validation State	000=Idle 001=Pre-warning 010=Inerting 011=Flushing 100=Validating
	3-5	Auto Validation Gas	000=zero gas 001=span gas 011=sample gas
	6	Auto Validation finishing	0=not finishing 1=finishing
	7	Auto Validation fail state	0=normal 1=failed
HI	0	Calibration mode on/off	0= off (normal); 1= on (alarms masked, jamming etc). Write 1 to turn calibration mode on.
	1	Cal point passed/failed	0= failed 1= passed
	2	Reserved	Reserved
	3	Enable Baseline Subtraction	0=disabled 1=enabled
	4-7	Reserved	Reserved

### D.5.3 DPv1 communications

The analyser is able to communicate using DPv1 asynchronous PROFIBUS communications with Class I and Class II masters. The following table shows the available data for DPv1 communication with Index and Slot numbers.

The user module/slot configuration on the PROFIBUS master device will not affect the DPv1 slot numbers, only Slot 1 is used.

Write requests are only accepted if the specified data lengths in the requests are same as the data lengths defined in slot/index table.

Slot	Index	Read / Write	# Words	Data
1	1	Read	72	Measurement 1 Data
1	2	Read/Write	34	Measurement 1 Control
1	11	Read	72	Measurement 2 Data
1	12	Read/Write	34	Measurement 2 Control
1	21	Read	72	Measurement 3 Data
1	22	Read/Write	34	Measurement 3 Control
1	31	Read	72	Measurement 4 Data
1	32	Read/Write	34	Measurement 4 Control
1	240	Read/Write	8	Resource Control
1	241	Read	32	Relay Data
1	242	Read	21	Resource Data
1	243	Read/Write	96	Relay Settings
1	250	Read	20	System Data
1	251	Read	18	System Settings

The field definitions for these indexed data spaces follow sequentially (definitions within a table also follow as commented).



<b>Measurement Data 1 - 4</b>		
<b>Word</b>	<b>Name</b>	<b>Comments</b>
0	Tag Number	16-bit user tag for this measurement
1-9	Name	Text Name for measurement 18 bytes
10-11	Measurement	32-bit IEEE float of displayed measurement
12-13	Pressure compensated	Pressure compensated measurement
14-15	Filtered measurement	Filtered measurement
16-17	Temperature	Chassis temperature
18-19	Faults and Alarms	Defined in Faults & Alarms table immediately below
20	Auto Validation State	Defined in Calibration 1-4 table below
21	Auto Validation Gas	Defined in Calibration 1-4 table below
22	Auto Validation Finishing	Defined in Calibration 1-4 table below
23	Auto Validation Fail State	Defined in Calibration 1-4 table below
24	Number of Cal / Val Points	Defined in Calibration 1-4 table below
25	Select Cal/Val Point*	Defined in Calibration 1-4 table below
26-27	Last Cal/Val Point n reading	
28-29	Last Cal Point n Target	32-bit float
30-31	Last Cal Point n Delta	32-bit float
32	Last Cal Point n Time	16-bit integer (hhmm)
33-34	Last Cal Point n Date[2]	32-bit integer (yymmdd)
35	Cal point passed/failed	

Measurement faults and alarms				
Word	Byte	Bit	Name	Comments
0	LOW	0	Warming On	
		1	Heater fault	
		2	Sample heater fault	
		3	Calibration fault	
		4	Communication fail	
		5	Transducer not detected	
		6	Auto-Cal validation / calibration failed	
	7	Remote validation / calibration failed denied		
	HI	0	Alarm Active	
		1	Fault	
		2	Service in progress	
		3	Out of specification	
		4	Maintenance required	
		5	Transducer maintenance fault	
6		Transducer error		
7	Transducer fatal fault			
1	LOW	0-7	Reserved	
	HI	0	Clipping Active	
		1	Remote service in progress	
		2	Transducer calibration mode	
		3	Auto-Cal validation/calibration	
		4	Incorrect transducer type	
5-7	Reserved			

Measurement 1-4 control				
Word	Byte	Bit	Name	Comments
0	LOW	0-7	Reserved	
	HI	0	Calibration mode on/off	
		1	Start Auto-Cal validation	
		2	Stop Auto-Cal validation	
		3	Enable baseline subtraction	
		4-7	Reserved	
1			Invoke calibration n	
2			Calibration point n gas	
3			Sample Gas Selection	
4			Select Cal/Val point	
5-6			Cross Interference correction/ GSF	
7-16			Reserved	

Resource Control 1-4 slot 1 index 240		
Byte	Name	Comments
0	cLegacy Pressure 1[8]	Defined in <b>Legacy Pressure n</b> table below
1	cLegacy Pressure 2[8]	
2	cLegacy Pressure 3[8]	
3	cLegacy Pressure 4[8]	
4	cLegacy Flow 1[8]	Defined in <b>Legacy Flow n</b> table below
5	cLegacy Flow 2[8]	
6	cLegacy Flow 3[8]	
7	cLegacy Flow 4[8]	

Legacy pressure n		
Bit	Name	Comments
0	Calibrate pressure mode	
1	Calibrate pressure low	
2	Calibrate pressure high	

Legacy flow n		
Bit	Name	Comments
0	Calibrate flow mode	
1	Calibrate zero flow	
2	Calibrate normal flow	

Relay Data slot 1 index 241		
Bit	Name	Comments
0	iRelay 01 status[8]	State, CardNotDetected or ServiceInProgress
:	iRelay n status[8]	State, CardNotDetected or ServiceInProgress
31	iRelay 32 status[8]	State, CardNotDetected or ServiceInProgress

Relay info n		
Bit	Name	Comments
0	State	
1	Card not detected	
2	Service in progress	

<b>Resource data (Slot 1 Index 242)</b>		
<b>Byte</b>	<b>Name</b>	<b>Comments</b>
0	iAOUT 1 status[8]	
1	iAOUT 2 status[8]	
2	iAOUT 3 status[8]	
3	iAOUT 4 status[8]	
4	iAIN 1 status[8]	
5	iAIN 2 status[8]	
6	iAIN 3 status[8]	
7	iAIN 4 status[8]	
8	iDin Card Not Detected[8]	
9	iLegacy Pressure 1 status [8]	
10	iLegacy Pressure 2 status [8]	
11	iLegacy Pressure 3 status [8]	
12	iLegacy Pressure 4 status [8]	
13	iLegacy Flow Alarm 1 status[16]	
14	iLegacy Flow Alarm 2 status[16]	
15	iLegacy Flow Alarm 3 status[16]	
16	iLegacy Flow Alarm 4 status[16]	
17-20	Chassis Temperature	

<b>Relay Settings (Slot 1 Index 243)</b>		
<b>Byte</b>	<b>Name</b>	<b>Comments</b>
0	iRelay 01 Active State	Rsc settings
1	iRelay 01 Override State	
2	iRelay 01 Override	
3	iRelay 02 Active State	
4	iRelay 02 Override State	
5	iRelay 02 Override	
:	iRelay n Active State	
:	iRelay n Override State	
:	iRelay n Override	
93	iRelay 32 Active State	
94	iRelay 32 Override State	
95	iRelay 32 Override	

<b>System data (Slot 1, Index 250)</b>		
<b>Word</b>	<b>Name</b>	<b>Comments</b>
0-9	hInstrument Serial Number [10]	System Data

<b>System settings (Slot 1, Index 251)</b>		
<b>Word</b>	<b>Name</b>	<b>Comments</b>
0	hService in Progress	System Control
1	System Controls	System Settings
2	hResponse Delay	
3	hClock: Hrs	
4	hClock: Mins	
5	hClock: Seconds	
6	hDate: Year	
7	hDate: Month	
8	hDate: Day	

<b>System controls word</b>			
<b>Byte</b>	<b>Bit</b>	<b>Name</b>	<b>Definition</b>
LOW	0-7	Reserved	
HI	0	Floating point order	
	1	User Interface busy	
	2	Disable user interface	
	3-7	Reserved	

## **D.6 PROFIBUS Troubleshooting**

### **D.6.1 The analyzer is not detected by the PROFIBUS master device**

- Check that the PROFIBUS cable is connected to the analyser, and the master device.
- Check that the termination resistors on the end points of the network are active.
- Check that the analyser node address is set up correctly on the master device.
- Check that there are no other devices configured to use the same address as the analyser.

Make sure that if there is more than one master device on the system, the correct master device is configured and connected to the analyser.

On the PROFIBUS master device, make sure that the correct "gsd" file has been used to configure the analyser, and at least one module is included in the configuration. Refer to your master device's manual to make sure all steps for the configuration have been followed.

Some PROFIBUS master devices are configured to stop reporting cyclic data as soon as an extended diagnostic error message is received. In this case either these faults have to be cleared on the analyser, or the master device has to be configured to continue normal operation when diagnostic bits are reported.

Make sure that the PROFIBUS baud rate selected at the Profibus master device, is suitable for the cabling setup.

Make sure that the PROFIBUS master is running.

Using the Status menu on the analyser, make sure that there is no "PROFIBUS card not detected" fault. This fault will require servicing of the analyser - Contact Servomex or your local Servomex representative.

### **D.6.2 The communication starts, but there are frequent line drops**

Make sure that the 'PROFIBUS Cabling Guidelines' have been followed. Refer to [www.profibus.com](http://www.profibus.com) for the latest guidelines.

If possible decrease the network baud rate.



# Appendix E Return Authorization Request

---

## E.1 Return Authorization Product Number Request

Servomex must approve and then assign a Return Product Authorization (RPA) Number to any instrument prior to being returned to the factory for repair. The RPA must appear on all paperwork and packaging. The issuance of an RPA does not automatically imply that the instrument is covered by our warranty.

In order to serve you better and to protect our employees from any potentially hazardous contaminants, Servomex must return, unopened and at the sender's expense, all items that do not have an RPA and a signed and filled out Decontamination Form.

OSHA Hazard Communication Standard 29CFR 1920.1200 mandated that we take specific steps to protect our employees from exposure to potential hazards. Therefore, a letter certifying that the equipment has been decontaminated must accompany all equipment exposed to hazardous contamination.

To obtain an RPA, fill out the form in section E.2 and email it to one of the following addresses:

**North and South America:** americas\_service@servomex.com

**Asia, Australia, New Zealand:** asia\_service@servomex.com

**Europe, Middle East, Africa, India:** eaemi\_service@servomex.com

## E.2 Return Product Authorization Number (RAN) Request Form

Thank you for requesting a Return Product Authorization (RAN) Number. We will acknowledge receipt of this form and will forward the RAN number to you.

<b>Date:</b>	
--------------	--

<b>Customer information:</b>		<b>End-user information: <i>(if different)</i></b>	
<b>Company name:</b>		<b>Company name:</b>	
<b>Address:</b>		<b>Address:</b>	
<b>Contact name:</b>		<b>Contact name:</b>	
<b>Phone:</b>		<b>Phone:</b>	
<b>Email:</b>		<b>Email:</b>	

<b>Billing information:</b>		<b>Shipping information:</b>	
<b>Name:</b>		<b>Name:</b>	
<b>Address:</b>		<b>Address:</b>	
<b>Contact name:</b>		<b>Contact name:</b>	
<b>Phone:</b>		<b>Phone:</b>	
<b>Email:</b>		<b>Email:</b>	
		<b>Shipping Instructions: (UPS/FedEx Acct, P&amp;A)</b>	

<b>Analyzer information:</b>			
<b>Part or model number:</b>	MultiExact 4200	<b>Serial number:</b>	
<b>Original purchase date:</b>		<b>PO number:</b>	

<b>Service requested: (check relevant option)</b>	<b>Repair</b>		<b>Required return</b>	
	<b>Calibration</b>		<b>Warranty / failure analysis</b>	
<b>Details of problem or failure:</b>				
<b>Do you require a rental unit?</b>	<b>No</b> <input type="checkbox"/>		<b>Yes</b> <input type="checkbox"/>	
<b>Do you require specific test documentation to be returned?</b>	<b>No</b> <input type="checkbox"/>		<b>Yes</b> <input type="checkbox"/>	
	<i>Servomex provides a Certificate of Calibration with each tested analyser. Any additional test documentation requested is subject to a test report fee.</i>			
<b>Have you attached a decontamination certificate?</b>	<b>No</b> <input type="checkbox"/>		<b>Yes</b> <input type="checkbox"/>	

<b>Shipping information:</b>
Please contact the relevant Servomex Support Office (below) for your location to obtain the shipping address.

<b>Servomex Support contact information:</b>	
North and South America:	americas_service@servomex.com
Asia, Australia, New Zealand:	asia_service@servomex.com
Europe, Middle East, Africa, India:	emeai_service@servomex.com

We look forward to receiving your request. If you have any questions regarding this form, please contact your local Servomex Support office.

Thank you for choosing Servomex.

## E.2 Decontamination Certificate

It is hereby certified that the equipment being returned, as described below, has been completely decontaminated and poses no possible toxic, corrosive, irritant, flammable, radioactive or biological hazard to any personnel required to unpack, handle, examine, maintain or repair it.

<b>Equipment / model:</b>	MultiExact 4200	<b>Serial number:</b>	
<b>Application / process:</b>			
<b>Substance(s) exposed to:</b>			

<b>Authorized customer contact information:</b>			
<b>Company name:</b>			
<b>Name:</b>		<b>Title:</b>	
<b>Phone:</b>		<b>Email:</b>	
<b>Signature:</b>			
<b>Date:</b>			

### IMPORTANT NOTICE:

Servomex ensures that all products dispatched to customers have been suitably purged and cleaned prior to packaging so that no hazards from the use of factory calibration gases or liquids are present.

## Appendix F Transducer FSD values

Table F-1: Transducer FSD values

Transducer	FSD (Full Scale)
GFX1210 CO High sensitivity (D1210701)	500ppm CO
GFX1210 CO Mid sensitivity (D1210701A)	1000ppm CO
GFX1210 CO Standard sensitivity (D1210702)	3000ppm CO
GFX1210 CO High range (D1210702A)	5000ppm CO
GFX 1210 CH <sub>4</sub> (D1210751)	500ppm CH <sub>4</sub>
GFX 1210 CH <sub>4</sub> High range (D1210751A)	1000ppm CH <sub>4</sub>
GFX 1210 N <sub>2</sub> O (D1210741)	500ppm N <sub>2</sub> O
IR 1520 100% CO <sub>2</sub>	100% CO <sub>2</sub>
IR 1520 50% CO <sub>2</sub>	50% CO <sub>2</sub>
IR 1520 25% CO <sub>2</sub>	25% CO <sub>2</sub>
IR 1520 10% CO <sub>2</sub>	10% CO <sub>2</sub>
IR 1520 5% CO <sub>2</sub>	5% CO <sub>2</sub>
IR 1520 2.5% CO <sub>2</sub>	2.5% CO <sub>2</sub>
IR 1520 1% CO <sub>2</sub>	1% CO
IR 1520 0.5% CO <sub>2</sub>	0.5% CO
IR 1520 0.25% CO <sub>2</sub>	0.25% CO <sub>2</sub>
IR 1522 100% CO	100% CO
IR 1522 50% CO	50% CO
IR 1522 25% CO	25% CO
IR 1522 10% CO	10% CO
IR 1522 2.5% CO	2.5% CO
IR 1522 1% CO	1% CO

## Appendix G Single Beam Single Wavelength (SBSW) transducer information

---

### G.1 Transducer low and high calibration

Zero grade nitrogen is recommended for low calibration.

It is recommended that the high calibration gas is in the range 80 to 110% of the transducer's FSD.

**Table G-1: Recommended calibration periods for SBSW NDIR transducers**

Gas transducer module	Low calibration	High calibration
SBSW NDIR transducer	Weekly	Daily

**Table G-2: SBSW NDIR transducer performance specification**

Gases measured	1521 CO <sub>2</sub> / 1522 CO
Range	See Table F-1
Minimum recommended output range	80% of selected range
Intrinsic error Linearity error Repeatability	1% of selected range
Lower Detection Limit (LDL) (95% confidence interval)	0.21% of selected range or 0.41% of reading, whichever is the larger
Response (T90)	<30 seconds at 1.5 l/min
Zero drift / week	2% of selected range
Span drift / day	1% of selected range
Output fluctuation (peak to peak)	0.5% of selected range or 1% of reading, whichever is the larger.
Ambient pressure coefficient	0.2% of reading per mbar
Ambient temperature coefficient / 10 °C change	1% of selected range ± <2.0% of reading
Sample flow effect range over full flow range	1.5% of selected range or <3% of reading, whichever is the larger.

**Table G-3: SBSW NDIR measurement ranges**

<b>Gases measured</b>	<b>Full scale measurement range (%)</b>								
	<b>0.25</b>	<b>0.5</b>	<b>1.0</b>	<b>2.5</b>	<b>5</b>	<b>10</b>	<b>25</b>	<b>50</b>	<b>100</b>
1520 CO <sub>2</sub>	✓	✓	✓	✓	✓	✓	✓	✓	✓
1522 CO			✓	✓		✓	✓	✓	✓

## Appendix H Paramagnetic transducer information

Table H-1: Recommended calibration periods for paramagnetic transducers

Gas transducer module	Low calibration	High calibration
Paramagnetic transducer	Weekly	Weekly

Table H-2: Paramagnetic transducer FSD values

Transducer	FSD
% O <sub>2</sub> (User set to 0-25%)	25% O <sub>2</sub>

Table H-3: Paramagnetic transducer performance specification

Gases measured	% O <sub>2</sub>
Range	0 – 25%
Minimum recommended output range	0 – 5%
Intrinsic error	± 0.1% O <sub>2</sub>
Linearity error <i>Inherently linear, dependent on calibration gases</i>	< 0.05% O <sub>2</sub>
Repeatability	< 0.1% O <sub>2</sub>
Lower Detection Limit (LDL) (95% confidence interval)	0.02% O <sub>2</sub>
Response (T90) at 1500ml/min	< 15 s
Zero drift / week	< 0.05% O <sub>2</sub>
Span drift / week	< 0.1% O <sub>2</sub>
Output fluctuation (peak to peak)	± 0.05% O <sub>2</sub>
Ambient pressure coefficient	Directly proportional to analyzer vent pressure
Zero temperature coefficient / 10 °C change	± 0.1% O <sub>2</sub>
Span temperature coefficient / 10 °C change	1% of reading or ± 0.1% O <sub>2</sub> , whichever is the larger.



Gases measured	% O <sub>2</sub>
Sample flow effect range over full flow range	< 2% of reading or 0.1% O <sub>2</sub> , whichever is the larger.

## H.1 Overview of measurement errors for paramagnetic O<sub>2</sub> transducer

For an O<sub>2</sub> transducer, the composition of any typical background gas in the gas sample will have an impact on the analyzer measurement accuracy.

Table H-4 below gives 4 examples of cross-interference errors (O<sub>2</sub> measurement errors) in gases which contain 100% of a specific background gas, for an analyzer which has been 'Lo' calibrated with N<sub>2</sub> (nitrogen) and 'Hi' calibrated with O<sub>2</sub>.

**Table H-4: Example cross-interference measurement errors**

Background gas	Error
Argon	-0.22%
Carbon dioxide	-0.26%
Halothane	-1.93%
Helium	-0.29%

Note that the error is directly proportional to the concentration of the background gas in the sample being measured and, in most cases, can be ignored. A detailed listing of these measurement errors for a wide variety of background gases are listed in Section 17.1H.2 below.

XINT is a reported concentration adjustment that can be set in the Paramagnetic Measurement menus. It is a scaling factor that is used to correct the current transducer reading. The default value is 1.0. If required the operator can change this value to compensate for the background gas. For example: If you are measuring oxygen in a background of carbon dioxide -0.26 should be entered as the XINT value.



**Figure H-1: XINT icon**

If XINIT compensation is to be used, care must be taken to insure that the value used for the background gases is correct. During a calibration, no XINT compensation is applied and it is assumed that the calibration gas sample has negligible cross-interference.

## H.2 Cross interference offsets (for paramagnetic transducer)

Pure gas	Formula	Molar mag. susc $\times 10^{-6}$	Cross interference offsets	
			20 °C	50 °C
Acetaldehyde	CH <sub>2</sub> CHO	-22.70	-0.31	-0.34
Acetic acid	CH <sub>3</sub> CO <sub>2</sub> H	-31.50	-0.56	-0.62
Acetone	CH <sub>3</sub> COCH <sub>3</sub>	-33.70	-0.63	-0.69
Acetylene	HCCH	-20.80	-0.25	-0.28
Acrylonitrile	CH <sub>2</sub> =CHCN	-24.10	-0.35	-0.39
Allyl alcohol	CH <sub>2</sub> CHCH <sub>2</sub> OH	-36.70	-0.71	-0.79
Ammonia	NH <sub>3</sub>	-18.00	-0.17	-0.19
Argon	Ar	-19.60	-0.22	-0.24
Benzene	C <sub>6</sub> H <sub>6</sub>	-54.84	-1.24	-1.36
Boron chloride	BCl <sub>3</sub>	-59.90	-1.38	-1.53
Boron trifluoride	BF <sub>3</sub>	-19.00	-0.20	-0.22
Bromine	Br <sub>2</sub>	-73.50	-1.78	-1.96
1,2 Butadiene	C <sub>4</sub> H <sub>6</sub>	-35.60	-0.68	-0.75
1,3 Butadiene	C <sub>4</sub> H <sub>6</sub>	-30.60	-0.54	-0.59
N-Butane	C <sub>4</sub> H <sub>10</sub>	-50.30	-1.11	-1.22
iso-Butane	(CH <sub>3</sub> ) <sub>2</sub> CHCH <sub>2</sub>	-51.70	-1.15	-1.26
1 Butene	CH <sub>3</sub> CH <sub>2</sub> CH=CH <sub>2</sub>	-41.10	-0.84	-0.93
N-Butyl acetate	CH <sub>3</sub> COOC <sub>4</sub> H <sub>9</sub>	-77.50	-1.89	-2.09
iso-Butylene	(CH <sub>3</sub> ) <sub>2</sub> CH=CH <sub>2</sub>	-44.40	-0.94	-1.03
1 Butyne (Ethylacetylene)	CH <sub>3</sub> C <sub>3</sub> H <sub>2</sub>	-43.50	-0.91	-1.00
Carbon dioxide	CO <sub>2</sub>	-21.00	-0.26	-0.29
Carbon disulphide	CS <sub>2</sub>	-42.20	-0.87	-0.96
Carbon monoxide	CO	-9.80	0.06	0.07
Carbon tetrachloride	CCl <sub>4</sub>	-66.60	-1.58	-1.74
Carbon tetrafluoride	CF <sub>4</sub>	-31.20	-0.55	-0.61

Pure gas	Formula	Molar mag. susc x 10 <sup>-6</sup>	Cross interference offsets	
			20 °C	50 °C
Chlorine	Cl <sub>2</sub>	-40.50	-0.82	-0.91
Chloroethanol	ClCH <sub>2</sub> CH <sub>2</sub> OH	-51.40	-1.14	-1.25
Chloroform	CHCl <sub>3</sub>	-59.30	-1.37	-1.51
Cumene	(CH <sub>3</sub> ) <sub>2</sub> CHC <sub>6</sub> H <sub>5</sub>	-89.53	-2.24	-2.47
Cyclohexane	C <sub>6</sub> H <sub>12</sub>	-68.13	-1.62	-1.79
Cyclopentane	C <sub>5</sub> H <sub>10</sub>	-59.18	-1.36	-1.50
Cyclopropane	C <sub>3</sub> H <sub>6</sub>	-39.90	-0.81	-0.89
Diacetylene	C <sub>4</sub> H <sub>2</sub>	-37.50	-0.74	-0.81
Dichloroethylene	(CHCl) <sub>2</sub>	-49.20	-1.07	-1.18
Diethyl ether	(C <sub>2</sub> H <sub>5</sub> ) <sub>2</sub> O	-55.10	-1.25	-1.37
2,2 Difluoro 1 chloroethane	CClH <sub>2</sub> CHF <sub>2</sub>	-52.40	-1.17	-1.29
1,2 Difluoro 1,2 dichloroethylene	CFCl=CFCl	-60.00	-1.39	-1.53
Difluoro dichloro methane (Freon 12)	CCl <sub>2</sub> F <sub>2</sub>	-52.20	-1.16	-1.28
Dimethoxy methane	CH <sub>2</sub> (OCH <sub>3</sub> ) <sub>2</sub>	-47.30	-1.02	-1.12
Dimethylamine	(CH <sub>3</sub> ) <sub>2</sub> NH	-39.90	-0.81	-0.89
Dimethylether	CH <sub>3</sub> OCH <sub>3</sub>	-26.30	-0.41	-0.46
Dimethylethylamine	(CH <sub>3</sub> ) <sub>2</sub> NC <sub>2</sub> H <sub>5</sub>	-63.60	-1.49	-1.64
Enflurane (Ethrane)	C <sub>3</sub> H <sub>2</sub> F <sub>5</sub> ClO	-80.10	-1.97	-2.17
Ethane	C <sub>2</sub> H <sub>6</sub>	-26.80	-0.43	-0.47
Ethanol	C <sub>2</sub> H <sub>5</sub> OH	-33.60	-0.62	-0.69
Ethyl acetate	CH <sub>3</sub> COOC <sub>2</sub> H <sub>5</sub>	-54.20	-1.22	-1.34
Ethyl amine	C <sub>2</sub> H <sub>5</sub> NH <sub>2</sub>	-39.90	-0.81	-0.89
Ethyl benzene	C <sub>6</sub> H <sub>5</sub> C <sub>2</sub> H <sub>5</sub>	-77.20	-1.88	-2.08
Ethyl bromide	C <sub>2</sub> H <sub>5</sub> Br	-54.70	-1.23	-1.36
Ethyl chloride	C <sub>2</sub> H <sub>5</sub> Cl	-46.00	-0.98	-1.08

Pure gas	Formula	Molar mag. susc x 10 <sup>-6</sup>	Cross interference effects	
			20 °C	50 °C
Ethylene	C <sub>2</sub> H <sub>4</sub>	-18.80	-0.20	-0.22
Ethylene glycol	(CH <sub>2</sub> OH) <sub>2</sub>	-38.80	-0.77	-0.85
Ethylene oxide	(CH <sub>2</sub> ) <sub>2</sub> O	-30.70	-0.54	-0.60
Ethyl mercaptan	C <sub>2</sub> H <sub>5</sub> OSO <sub>3</sub> H	-47.00	-1.01	-1.11
Fluorochlorobromomethane	CFCIBr	-58.00	-1.33	-1.46
Fluorodichloromethane (Freon 21)	CHCl <sub>2</sub> F	-48.80	-1.06	-1.17
Fluroxene	CF <sub>3</sub> CH <sub>2</sub> OCHCH <sub>2</sub>	-56.70	-1.29	-1.42
Freon 114	C <sub>2</sub> Cl <sub>2</sub> F <sub>4</sub>	-77.40	-1.89	-2.08
Furan	C <sub>4</sub> H <sub>4</sub> O	-43.09	-0.90	-0.99
Germanium tetrachloride	GeCl <sub>4</sub>	-72.00	-1.73	-1.91
Halothane	C <sub>2</sub> HBrClF <sub>3</sub>	-78.80	-1.93	-2.13
Helium	He	-1.88	0.29	0.32
N-Heptane	C <sub>7</sub> H <sub>16</sub>	-85.24	-2.12	-2.33
N-Hexane	C <sub>6</sub> H <sub>14</sub>	-73.60	-1.78	-1.96
Hydrogen	H <sub>2</sub>	-3.98	0.23	0.26
Hydrogen bromide	Br	-35.30	-0.67	-0.74
Hydrogen chloride	HCl	-22.60	-0.31	-0.34
Hydrogen cyanide	HCN	-14.50	-0.07	-0.08
Hydrogen iodide	HI	-48.20	-1.05	-1.15
Hydrogen selenide	H <sub>2</sub> Se	-39.20	-0.79	-0.87
Hydrogen sulphide	H <sub>2</sub> S	-25.50	-0.39	-0.43
Isoflurane (Forane)	C <sub>3</sub> H <sub>2</sub> F <sub>5</sub> ClO	-80.10	-1.97	-2.17
Isoprene	C <sub>5</sub> H <sub>8</sub>	-44.80	-0.95	-1.04
Ketene	CH <sub>2</sub> CO	-15.70	-0.11	-0.12
Krypton	Kr	-28.80	-0.49	-0.54
Methane	CH <sub>4</sub>	-17.40	-0.16	-0.17

Pure gas	Formula	Molar mag. susc $\times 10^{-6}$	Cross interference effects	
			20 °C	50 °C
Methanol	CH <sub>3</sub> OH	-21.40	-0.27	-0.30
Methoxyfluorane	CHCl <sub>2</sub> CF <sub>2</sub> OCH <sub>3</sub>	-87.10	-2.17	-2.39
Methyl acetate	CH <sub>3</sub> COCH <sub>3</sub>	-42.60	-0.88	-0.97
Methyl cyclopentane	C <sub>6</sub> H <sub>12</sub>	-70.20	-1.68	-1.85
Methylene chloride	CH <sub>2</sub> Cl <sub>2</sub>	-46.60	-1.00	-1.10
Methylethylketone	CH <sub>3</sub> COCH <sub>2</sub> CH <sub>3</sub>	-45.50	-0.97	-1.07
Methyl fluoride	CH <sub>3</sub> F	-25.50	-0.39	-0.43
Methyl formate	HCOOCH <sub>3</sub>	-32.00	-0.58	-0.64
Methyl iodide	CH <sub>3</sub> I	-57.20	-1.31	-1.44
Methyl iso-butyl ketone (MIBK)	C <sub>4</sub> H <sub>9</sub> COCH <sub>3</sub>	-69.30	-1.66	-1.82
Methyl mercaptan	CH <sub>3</sub> SH	-35.30	-0.67	-0.74
Molybdenum hexafluoride	MoF <sub>6</sub>	-26.00	-0.40	-0.45
Monochlorobenzene	C <sub>6</sub> H <sub>5</sub> Cl	-70.00	-1.68	-1.85
Neon	Ne	-6.70	0.15	0.17
Nitric oxide	NO	1461.00	42.56	42.96
Nitrobenzene	C <sub>6</sub> H <sub>5</sub> NO <sub>2</sub>	-61.80	-1.44	-1.59
Nitrogen	N <sub>2</sub>	-12.00	0.00	0.00
Nitrogen dioxide	NO <sub>2</sub>	150.00	5.00	16.00
Ortho-Nitrotoluene	C <sub>6</sub> H <sub>4</sub> CH <sub>3</sub> NO <sub>2</sub>	-72.30	-1.74	-1.92
para-Nitrotoluene	C <sub>6</sub> H <sub>4</sub> CH <sub>3</sub> NO <sub>2</sub>	-76.90	-1.88	-2.07
Nitrous oxide	N <sub>2</sub> O	-18.90	-0.20	-0.22
N-Nonane	C <sub>9</sub> H <sub>20</sub>	-108.13	-2.78	-3.06
N-Octane	C <sub>8</sub> H <sub>18</sub>	-96.63	-2.45	-2.70
Oxygen	O <sub>2</sub>	3449.00	100.0	100.0
Ozone	O <sub>3</sub>	6.70	0.54	0.60
iso-Pentane	C <sub>5</sub> H <sub>12</sub>	-64.40	-1.51	-1.67

Pure gas	Formula	Molar mag. susc $\times 10^{-6}$	Cross interference offsets	
			20 °C	50 °C
N-Pentane	$C_5H_{12}$	-63.10	-1.48	-1.63
0.01%Phenol	$C_6H_5OH$	-60.21	-1.39	-1.54
Phosphine	$PH_3$	-26.00	-0.40	-0.45
Phosphorous oxychloride	$POCl_3$	-69.00	-1.65	-1.82
Propane	$C_3H_8$	-38.60	-0.77	-0.85
iso-Propanol	$(CH_3)_2CHOH$	-47.60	-1.03	-1.13
Propene	$CH_3CH=CH_2$	-31.50	-0.56	-0.62
N-Propyl acetate	$CH_3COOC_3H_7$	-65.90	-1.56	-1.72
Propyl amine	$C_3H_7NH_2$	-52.40	-1.17	-1.29
Propyl chloride	$C_3H_7Cl$	-56.10	-1.27	-1.40
Propylene	$C_3H_6$	-31.50	-0.56	-0.62
Propylene oxide	$OCH_2CHCH_3$	-42.50	-0.88	-0.97
iso-Propyl ether	$(CH_3)_4CHOCH$	-79.40	-1.95	-2.15
Propyl fluoride	$C_3H_7F$	-52.20	-1.16	-1.28
Pyridine	$N(CH)_5$	-49.21	-1.08	-1.19
Silane	$SiH_4$	-20.50	-0.25	-0.27
Silicon tetrachloride	$SiCl_4$	-88.30	-2.20	-2.43
Styrene	$C_6H_5CH=CH_2$	-68.20	-1.62	-1.79
Sulphur dioxide	$SO_2$	-18.20	-0.18	-0.20
Sulphur hexafluoride	$SF_6$	-44.00	-0.92	-1.02
Tetrachoroethylene	$Cl_2C=CCl_2$	-81.60	-2.01	-2.22
Tetrahydrofuran	$C_4H_8O$	-52.00	-1.16	-1.27
Toluene	$C_6H_5CH_3$	-66.11	-1.56	-1.72
1,1,2 Trichloroethane (Freon 113)	$CHCl_2CH_2Cl$	-66.20	-1.57	-1.73
Trichloroethylene	$CHCl=CCl_2$	-65.80	-1.55	-1.71
Trifluorochloroethylene	$C_2F_3Cl$	-49.10	-1.07	-1.18

Pure gas	Formula	Molar mag. susc x 10 <sup>-6</sup>	Cross interference offsets	
			20 °C	50 °C
Trimethylamine	(CH <sub>3</sub> ) <sub>3</sub> N	-51.70	-1.15	-1.26
Tungsten fluoride	WF <sub>6</sub>	-40.00	-0.81	-0.89
Urethane	CO(NH <sub>2</sub> )OC <sub>2</sub> H <sub>5</sub>	-57.00	-1.30	-1.43
Vacuum	-	0.00	0.35	0.38
Vinyl bromide	CH <sub>2</sub> =CHBr	-44.80	-0.95	-1.04
Vinyl chloride	CH <sub>2</sub> =CHCl	-35.60	-0.68	-0.75
Vinyl fluoride	CH <sub>2</sub> =CHF	-28.80	-0.49	-0.54
Water	H <sub>2</sub> O	-13.00	-0.03	-0.03
Xenon	Xe	-43.90	-0.92	-1.02
Xylene	(CH <sub>3</sub> ) <sub>2</sub> C <sub>6</sub> H <sub>4</sub>	-77.78	-1.90	-2.09

# Appendix I 1210 Gas Filter Correlation (GFX) transducer information

## I.1 GFX transducer low and high calibration

The low calibration gas for GFX gas transducer modules may be specified between -5 ppm and +5 ppm of the measured component. Zero grade nitrogen is recommended.

The high calibration gas can be in the range 6 to 110% of the transducer's Full Scale Deflection (FSD). As GFX transducers are configured as 'dual range' units, it is recommended that the high calibration gas is selected at the top end of the range used.

**Table I-1: Recommended calibration periods for GFX transducers**

Gas transducer module	Low calibration	High calibration
1210 GFX transducer	Weekly	Monthly

**Table I-2: 1210 GFX transducer FSD values for calibration**

Transducer	FSD
GFX1210 CO High sensitivity	500 ppm CO
GFX1210 CO Mid sensitivity	1000 ppm CO
GFX1210 CO Standard sensitivity	3000 ppm CO
GFX1210 CO High range	5000 ppm CO
GFX 1210 CH <sub>4</sub> Standard range	500 ppm CH <sub>4</sub>
GFX 1210 CH <sub>4</sub> High range	1000 ppm CH <sub>4</sub>
GFX 1210 N <sub>2</sub> O	500 ppm N <sub>2</sub> O



**Table I-3: 1210 GFX transducer performance specification**

<b>Gases measured</b>	<b>GFX CO high range</b>	<b>GFX CO standard sensitivity</b>	<b>GFX CO mid sensitivity</b>	<b>GFX CO high sensitivity</b>	<b>GFX N<sub>2</sub>O trace</b>
Range	0 – 5000 ppm	0 – 3000 ppm	0 - 1000 ppm	0 - 500 ppm	0 – 500 ppm
Min. recommended output range	0 – 500 ppm	0 – 200 ppm	0 - 100 ppm	0 - 50 ppm	0 – 10 ppm
Intrinsic error Linearity error Repeatability	1% of reading, or 5 ppm*	1% of reading, or 2 ppm*	1% of reading, or 1 ppm*	1% of reading, or 0.5 ppm*	1% of reading, or 0.5 ppm*
Lower Detection Limit (LDL) (95% confidence interval)	0.41% of reading or 2.1 ppm*	0.41% of reading or 0.82 ppm*	0.41% of reading or 0.41 ppm*	0.41% of reading or 0.21 ppm*	0.41% of reading or 0.21 ppm*
Response (T90)	< 30 seconds at 1500 ml/min				
Zero drift / week	10 ppm	4 ppm	2 ppm	1 ppm	1 ppm
Span drift / week	2% of reading, or 10 ppm*	2% of reading, or 4 ppm*	< 2% of reading, or 2 ppm*	< 2% of reading, or 1 ppm*	2% of reading, or 1 ppm*
Output fluctuation (peak to peak)	1% of reading, or 5 ppm*	1% of reading, or 2 ppm*	< 1% of reading, or 1 ppm*	< 1% of reading, or 0.5 ppm*	1% of reading, or 0.5 ppm*
Ambient pressure coefficient	0.25%	0.25%	0.25%	0.25%	0.5%
	Of reading per 1% change in analyser vent pressure				
Ambient temperature coefficient / 10 °C change	3% of reading, or 10 ppm CO*	3% of reading, or 4 ppm CO*	< 3% of reading, or 2 ppm CO*	< 3% of reading, or 1 ppm CO*	3% of reading, or 1 ppm N <sub>2</sub> O*
Sample flow effect range 1.5 to 2.5 l/min	< 1% of reading, or 10 ppm CO*	< 1% of reading, or 2 ppm CO*	< 1% of reading, or 2 ppm CO*	< 1% of reading, or 0.5 ppm CO*	< 1% of reading, or 0.5 ppm N <sub>2</sub> O*

\* whichever is the larger

<b>Gases measured</b>	<b>GFX CH<sub>4</sub> high range</b>	<b>GFX CH<sub>4</sub> standard range</b>
Range	0 – 1000 ppm	0 – 500 ppm
Min. recommended output range	0 – 100 ppm	0 – 10 ppm
Intrinsic error Linearity error Repeatability	1% of reading, or 1 ppm*	1% of reading, or 0.5 ppm*
Lower Detection Limit (LDL) (95% confidence interval)	0.41% of reading or 0.41 ppm*	0.41% of reading or 0.21 ppm*
Response (T90)	< 30 seconds at 1500 ml/min	
Zero drift / week	2 ppm	1 ppm
Span drift / week	2% of reading, or 2 ppm*	2% of reading, or 1 ppm*
Output fluctuation (peak to peak)	1% of reading, or 1 ppm*	1% of reading, or 0.5 ppm*
Ambient pressure coefficient	1%	1%
	Of reading per 1% change in analyser vent pressure	
Ambient temperature coefficient / 10 °C change	3% of reading, or 2 ppm CH <sub>4</sub> *	3% of reading, or 1.5 ppm CH <sub>4</sub> *
Sample flow effect range 1.5 to 2.5 l/min	< 1% of reading, or 2 ppm CH <sub>4</sub> *	< 1.5% of reading, or 0.5 ppm CH <sub>4</sub> *

\* whichever is the larger

**Table I-4: 1210 GFX transducer trace measurement cross-sensitivity information**

<b>Interferent:</b>	<b>O<sub>2</sub></b>	<b>CO<sub>2</sub></b>	<b>CO</b>	<b>H<sub>2</sub>O</b>
<b>GFX 1210 CH<sub>4</sub></b>	1% O <sub>2</sub> ~ 0.5 ppm		0.2% CO ~ 0.5 ppm	0.5% H <sub>2</sub> O < 1 ppm
<b>GFX 1210 CO</b> All except high sensitivity		20% CO <sub>2</sub> ~ 2 ppm		2% H <sub>2</sub> O ~ 0.5 ppm
<b>GFX 1210 CO</b> High sensitivity		20% CO <sub>2</sub> ~ 1 ppm		2% H <sub>2</sub> O ~ 0.5 ppm
<b>GFX 1210 N<sub>2</sub>O</b>		500 ppm CO <sub>2</sub> ~ 0.5 ppm	10 ppm CO ~ 0.5 ppm	2% H <sub>2</sub> O ~ 0.5 ppm

## Appendix J Sample wetted materials information

---

Table J-1: Sample wetted materials

Material	Transducer type		
	Paramagnetic % O <sub>2</sub>	1210 series GFX NDIR	1520 series SBSW NDIR
Stainless Steel 303	✓	✓	✓
Stainless Steel 316	✓	✓	✓
Borosilicate glass	✓		
Platinum	✓		
Platinum Iridium alloy	✓		
Electroless Nickel	✓		
Gold		✓	
Calcium Fluoride		✓	
Nickel		✓	
Sapphire			✓
Epoxy resin			✓

**Table J-2: Additional materials**

<b>Feature</b>	<b>Additional materials</b>
Stream systems	Stainless steel

# Index

---

## 1

1210 Gas Filter Correlation (GFX) transducer information .....228

## A

### alarms

activation.....73  
alarm modes.....71  
hysteresis effects.....71  
hysteresis levels.....71  
icon.....45  
threshold levels.....70  
navigation tools.....70

analog output interface connectors .....24, 25

analyzer menu branch structure .....47

diagnostics.....54  
maintenance.....54  
measurement.....47  
settings.....55  
top level.....47

applicable standards.....181

auto-cal calibration.....143

configuration.....65

auto-cal external inputs.....166

auto-cal sequence timing.....163

general.....163  
multiple transducers.....165

auto-cal threshold settings.....161

auto-cal validation.....143

auto-cal valve installation.....165

auto-calibration.....153

flow diagram.....153  
full sequence example.....153  
sequence steps.....153  
flow diagram.....153  
setup screen.....158  
truncated sequence example.....155

auto-validation.....146

flow diagram.....146  
full sequence example.....146  
icons.....151  
sequence steps.....146

flow diagram.....146  
setup screen.....150  
truncated sequence example.....148

## B

bench mounting.....22

## C

### calibration

auto-cal.....143  
manual.....138

calibration log.....97, 99

display.....97, 99

calibration log file.....167

cleaning.....171

compliance and standards.....181

### connections

relay.....28  
relay.....27  
span & sample gas relay (auto-cal).....29  
zero gas relay (auto-cal).....29

contents.....3

## D

date.....115

decontamination certificate.....216

diagnostics branch.....93

calibration log.....97, 99  
display.....97, 99

icons.....93, 94

relay testing.....95

saving system log files.....95

system log.....97, 99  
display.....97, 99

digital inputs.....120

icons.....122

disposal.....175

## E

electrical installation.....24

analog output connections.....24

electrical safety.....24

electrical supply connection.....30

relay connections .....	26
electrical specification .....	168
EMC considerations .....	18
environmental limits.....	170
error codes.....	174
EU directives .....	181

## **F**

faults	
icon .....	45
frequently used	
icons .....	44
frequently used icons	
accept .....	44
alarm settings .....	44
calibrate.....	44
cancel .....	44
diagnostics screen .....	44
exit.....	44
home screen.....	44
main menu .....	44
maintenance screen .....	44
measurement screen.....	44
next list.....	44
return .....	44
settings screen.....	44
fuse holder .....	173
fuse panel .....	172
fuse replacement.....	171

## **G**

gas connections .....	32
gas flow rate .....	32
gas inlets and outlets.....	21
gas pipeline connection .....	31
gas connections.....	32
gas flow rate.....	32
inlets and outlets.....	31
gas reporting units.....	86
configuration .....	86

## **H**

Home screen.....	42
------------------	----

## **I**

index .....	235
inputs.....	116

installation and set-up .....	20
electrical installation .....	24
analog output connections .....	24
electrical safety .....	24
electrical supply connection .....	30
relay connections.....	26
gas pipeline connection.....	31
gas connections .....	32
gas flow rate .....	32
gas inlets and outlets .....	31
mechanical installation .....	22
bench mounting.....	22
rack mounting.....	22
unpacking .....	20
introduction.....	7
automatic calibration intervals .....	12
general description .....	9
manual conventions.....	7
product identification.....	12
product overview .....	8
recommended calibration intervals .....	11
regulatory information.....	8
safety information conventions .....	7
sample requirements .....	14
scope .....	7

## **J**

jam conditions .....	174
----------------------	-----

## **M**

mA analog inputs.....	117
icons .....	119
mA output	
icons .....	76
main screen	
icons .....	43
maintenance branch.....	98
icons .....	98, 99
maintenance policy .....	180
manual calibration.....	138
configuration.....	65
high span .....	126, 127, 130, 139
icons .....	139
zero or low span.....	142
manual calibration and auto-cal sequences .....	136
auto-cal external inputs .....	166

auto-cal sequence timing .....	163	transducer diagnostics .....	87, 91
auto-cal threshold settings.....	161	measurement data filter.....	86
auto-cal validation and calibration.....	143	configuration .....	86
auto-cal valve installation .....	165	setting.....	86, 87, 89, 91
auto-calibration full sequence example .....	153	types.....	86
auto-calibration sequence steps .....	153	measurement gas reporting units .....	123, 124
flow diagram .....	153	measurement icons .....	45
auto-calibration setup screen .....	158	measurement mA output	
auto-calibration truncated sequence example .....	155	configuration	
auto-validation full sequence example .....	146	icons .....	82
auto-validation sequence steps .....	146	measurement range setting	
flow diagram .....	146	icons .....	76
auto-validation setup screen.....	150	measurement record .....	81, 83, 84
auto-validation truncated sequence example .....	148	configuration .....	81, 83, 84
calibration gas standard requirements .....	137	icons .....	85, 90
calibration log file.....	167	mechanical installation.....	22
definition of terms.....	136	bench mounting .....	22
introduction to calibration .....	136	rack mounting .....	22
manual calibration.....	138	mechanical specification .....	168
recommended calibration periods .....	138	menu screen .....	43
relays .....	166	Modbus communications .....	187
manual high span and zero icons.....	142		
manual over-ride .....	113	<b>O</b>	
icons .....	114	operation	
markings .....	19	switch on and set up .....	35
measurement alarms.....	66	operation .....	34
activated alarms .....	73	power up .....	35
alarms settings .....	66	switch off.....	34
configuration .....	66	view flow levels .....	34
hysteresis levels.....	71		
icons .....	68	<b>P</b>	
screen .....	66	paramagnetic transducer information .....	220
settings .....	66	paramagnetic transducers	
sub-branch icons .....	69	cross interference offsets.....	222
threshold levels .....	70	measurement errors .....	221
measurement branch .....	61	password protection.....	110
configuring calibration .....	65	icons .....	111
auto-cal .....	65	operations .....	111
manual .....	65	power up.....	35
configuring gas recording units .....	86	preventative maintenance .....	173
configuring measurement data filter .....	86	product identification .....	12
configuring measurement record option .....	81, 83, 84	PROFIBUS.....	197
configuring user ranges .....	74	description .....	197
icons .....	64	DPVO features.....	199
measurement alarm configuration .....	66	electrical installation .....	197
screens .....	61	safety.....	197



settings .....	198
troubleshooting .....	212

## R

rack mounting .....	22
RAN .....	175, 214
rear panel connections .....	13
relay activity functions .....	107
assigning alarms for external 4-20mA inputs .....	109
assigning alarms, functions and activities .....	107
icons .....	109
relay testing .....	95
Return Authorization Number .....	175
Return Authorization Request .....	213
Return Product Authorization Number Request Form .....	214
routine checks .....	171
fuse .....	171
routine maintenance .....	171
cleaning .....	171
routine checks .....	171
fuse replacement .....	171
RS232 .....	182
connections .....	182
streaming output .....	185
RS485 .....	182
connections .....	182
RS485 / RS232 .....	182
connections .....	182
serial set up parameters .....	183
streaming RS232 output .....	185

## S

safety .....	16
chemical warnings .....	17
electrical warnings .....	17
general warnings .....	16
markings .....	19
safety warnings .....	16
sample and calibration gas inlets and outlets .....	31
sample port fittings .....	32
sample requirements .....	14
sample wetted materials information .....	233
SBSW .....	218
screen settings .....	124, 130, 131, 134
icons .....	125, 126
serial mA outputs .....	102

icons .....	106
-------------	-----

## serial parameters

icons .....	183
serial set up parameters .....	183
set date .....	115
set inputs .....	116
set time .....	116
settings branch .....	100
assign password protection .....	110
assign relay activity functions .....	107
icons .....	101
manual relay over-ride setting .....	113
measurement gas reporting units .....	123, 124
screen settings .....	124, 130, 131, 134
serial mA outputs .....	102
setting date .....	115
setting inputs .....	116
digital inputs .....	120
mA analog inputs .....	117
setting time .....	116
Single Beam Single Wavelength (SBSW) transducer	
information .....	218
spares .....	176
storage .....	175
switch off .....	34
switch on and set up .....	35
system icons .....	45
system log .....	97, 99
display .....	97, 99
system log files .....	95

## T

technical specification .....	168
electrical .....	168
environmental limits .....	170
maximum voltage ratings .....	169
mechanical .....	168
time .....	116
touchscreen	
icons .....	44
operation .....	39
transducer diagnostics .....	87, 91
Transducer FSD and availability .....	217
transducer FSD values .....	217
troubleshooting .....	174
error codes .....	174

jam conditions .....	174
<b>U</b>	
unpacking.....	20
user interface.....	37
general techniques .....	38
measurement icons.....	45
system icons.....	45
touchscreen icons .....	44
touchscreen operation.....	39
Home screen .....	42
introduction.....	37
menu screen .....	43
overview .....	37
user ranges	
auto range .....	78
auto-range examples.....	79
configuration .....	74

custom expanded range.....	74, 77
custom user high range.....	78
custom user low range .....	78
range setting example.....	79
<b>V</b>	
validation	
auto-cal .....	143
voltage ratings .....	169
<b>W</b>	
warnings	
chemical .....	17
electrical .....	17
general .....	16
warranty .....	179
WEEE Directive .....	175