

Electromagnetic Flow Meters

M5000 Converting a Standard Mount to a Remote Mount

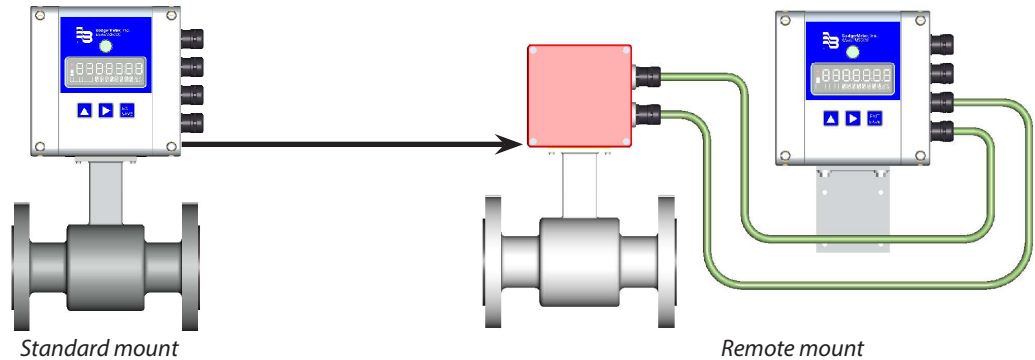

Description

These instructions explain how to convert a standard mount M5000 meter to a remote mount using the Remote Junction Box Kit, PN 63384-043. Contents of the kit are:

- Remote junction box, red aluminum, 122 × 120 × 80 mm with 2 metal cable glands and 4 copper screws, qty. 1
- Remote junction box PCB, qty. 1
- Remote mounting bracket, qty. 1
- Socket head cap screws, M5 × 16, qty. 4
- Stat-O-Seal washers M5, qty. 4
- Gasket, rectangular, 75 × 45 mm, qty.1

CAUTION

CONTAINS PARTS AND ASSEMBLIES SUSCEPTIBLE TO DAMAGE BY ELECTROSTATIC DISCHARGE (ESD). BEFORE PICKING UP AN ESD-SENSITIVE ELECTRONIC COMPONENT, DISCHARGE YOURSELF BY TOUCHING A GROUNDED BARE METAL SURFACE OR APPROVED ANTI-STATIC MAT.

WARNING

TURN OFF POWER BEFORE PERFORMING ANY WORK ON THE M5000 METER.

See "[Wiring Reference for Remote Configuration](#)" on page 4 for the wiring overview.

Tools Required

- Flathead screwdriver
- 4 mm or 5/32 in. bit
- Electric driver
- Torque screwdriver 4.7 Nm
- Torque wrench 5.2 Nm

Junction Box Assembly

1. Disconnect the electrode and coil terminal blocks in the amplifier housing.

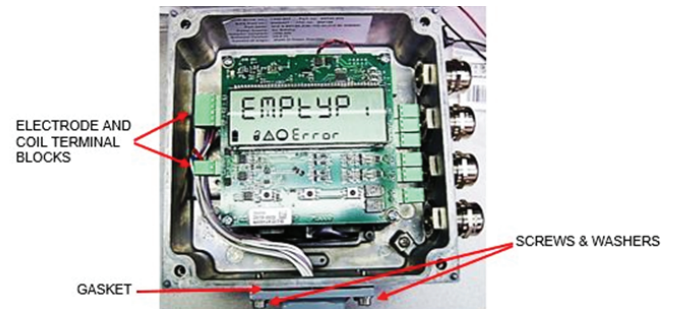

Figure 1: M5000 junction box

2. Using the 4 mm or 5/32 in. bit and electric driver, remove the bottom four bolts and washers from the amplifier and slide the detector away from the amplifier making sure the gasket is not lost. See [Figure 1](#).
3. On each cable (one black, one white), inspect each wire connection to verify that the ferrules at both cable ends do not slide off the ends of the wire by gently pulling on the ferrules. If any are lacking a proper electrical connection, replace them.

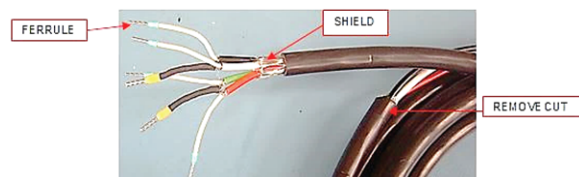

Figure 2: M5000 cables

- Attach the PCB to the inside of the junction box with four (4) copper screws. See [Figure 3](#).
- Thread two (2) metal cable glands into the junction box. Torque the cable gland nuts to 5.2 Nm. See [Figure 3](#).

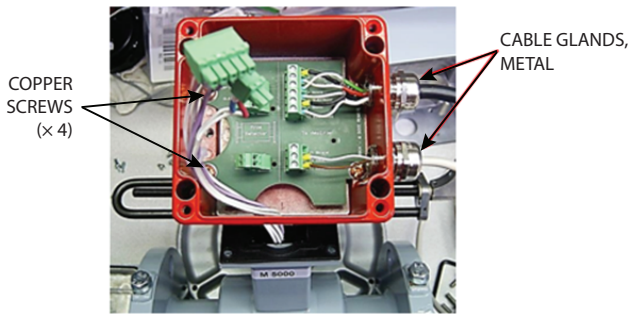

Figure 3: M5000 junction box

- Slide the white cable through the lower cable gland and pull the cable forward until the exposed shielding is covered by the grounding prongs on the gland.

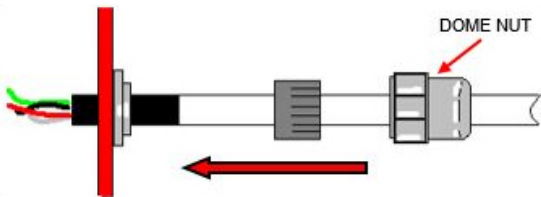

Figure 4: M5000 junction box lower cable gland

- Attach the white cable wires (the end with the shorter exposed wires) to the 3-pin connector on the junction box circuit board (see [Figure 5](#) for wiring).
- Slide the black cable through the upper cable gland and pull the cable forward until the shielding is covered by the grounding prongs on the gland (see [Figure 4](#)).
- Attach the black cable wires (the end with the shorter exposed wires) to the 6-pin connector on the junction box circuit board (see [Figure 5](#) for wiring).

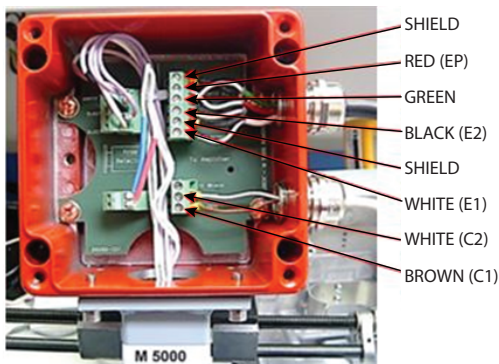

Figure 5: M5000 connector cable wires

- Slide the seal/grip and dome nut into position (see [Figure 4](#)). Visually confirm the shielding is in contact with the gland prongs, then tighten the dome nut to 5.2 Nm, securing the cable in place.
- Using the 4 mm or 5/32 in. bit and electric driver, attach the junction box to the detector with the gasket in between. Use the same bolts that were removed when

the amplifier and detector were disassembled. Torque the bolts to 4.7 Nm.

- Remove the electrode and coil terminal blocks from the junction box circuit board.
- Connect the *electrode* and *coil* connectors from the detector to the junction box PCB.
- Plug the detector's electrode and coil terminal blocks into the junction box circuit board (see [Figure 5](#)) and tuck wires neatly inside. **DO NOT ROUTE THE WIRES UNDER THE JUNCTION BOX CIRCUIT BOARD!**

Amplifier Assembly

Using the components from junction box kit:

- Place four (4) M5 Stat-O-Seal washers on four (4) M5 x 16 socket head cap screws.
- Set the *gasket* on the amplifier box. See [Figure 6](#).
- Lay the *wall bracket* on the gasket. See [Figure 6](#).
- Thread the four (4) screws with washers into the wall bracket and torque to 4.7 Nm. See [Figure 6](#).

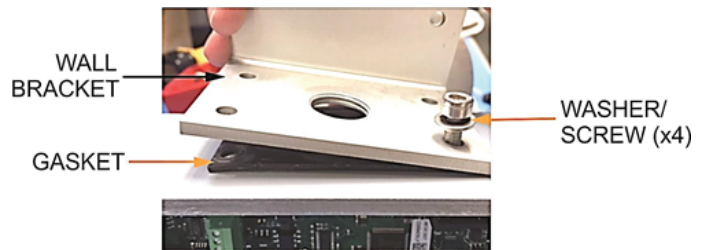

Figure 6: M5000 gasket on amplifier

- Remove the bottom two (2) cable glands on the amplifier and remove the plugs from the cable glands. See [Figure 7](#).

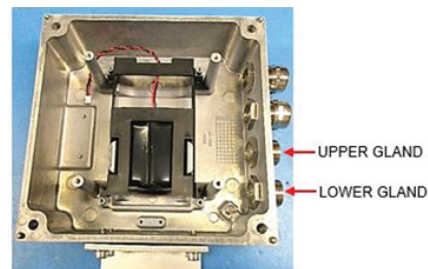

Figure 7: M5000 amplifier housing

- Replace the upper cable gland dome nut. See [Figure 7](#).
- Insert the black cable (the end with longer exposed wires) through the upper cable gland. Tighten cable gland and torque to 5.2 Nm.
- Replace the lower cable gland dome nut. See [Figure 7](#).
- Insert the white cable (the end with longer exposed wires) through the lower cable gland. Tighten cable gland and torque to 5.2 Nm.

- Using the electrode and coil terminal blocks removed from the junction box circuit boards, connect the wires per [Figure 8](#), making sure all connections are secure.

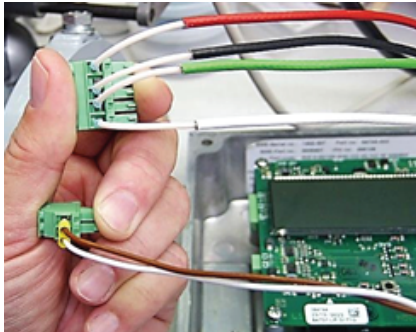

Figure 8: M5000 electrode and coil terminal blocks

- Route the wires of the electrode and coil terminal blocks around the bottom of the amplifier housing. See [Figure 9](#).

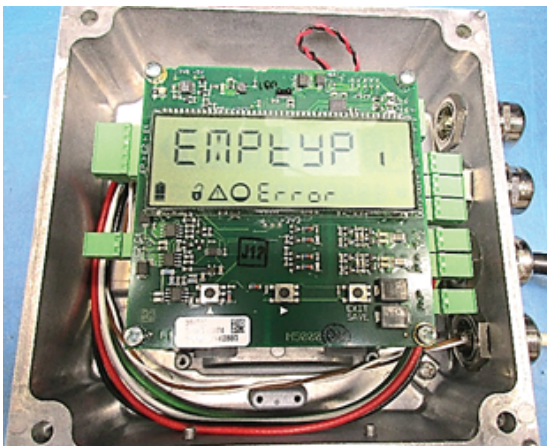

Figure 9: M5000 wires routed around bottom of housing

- Attach battery wire harness to amplifier PCB.

Wiring Reference for Remote Configuration

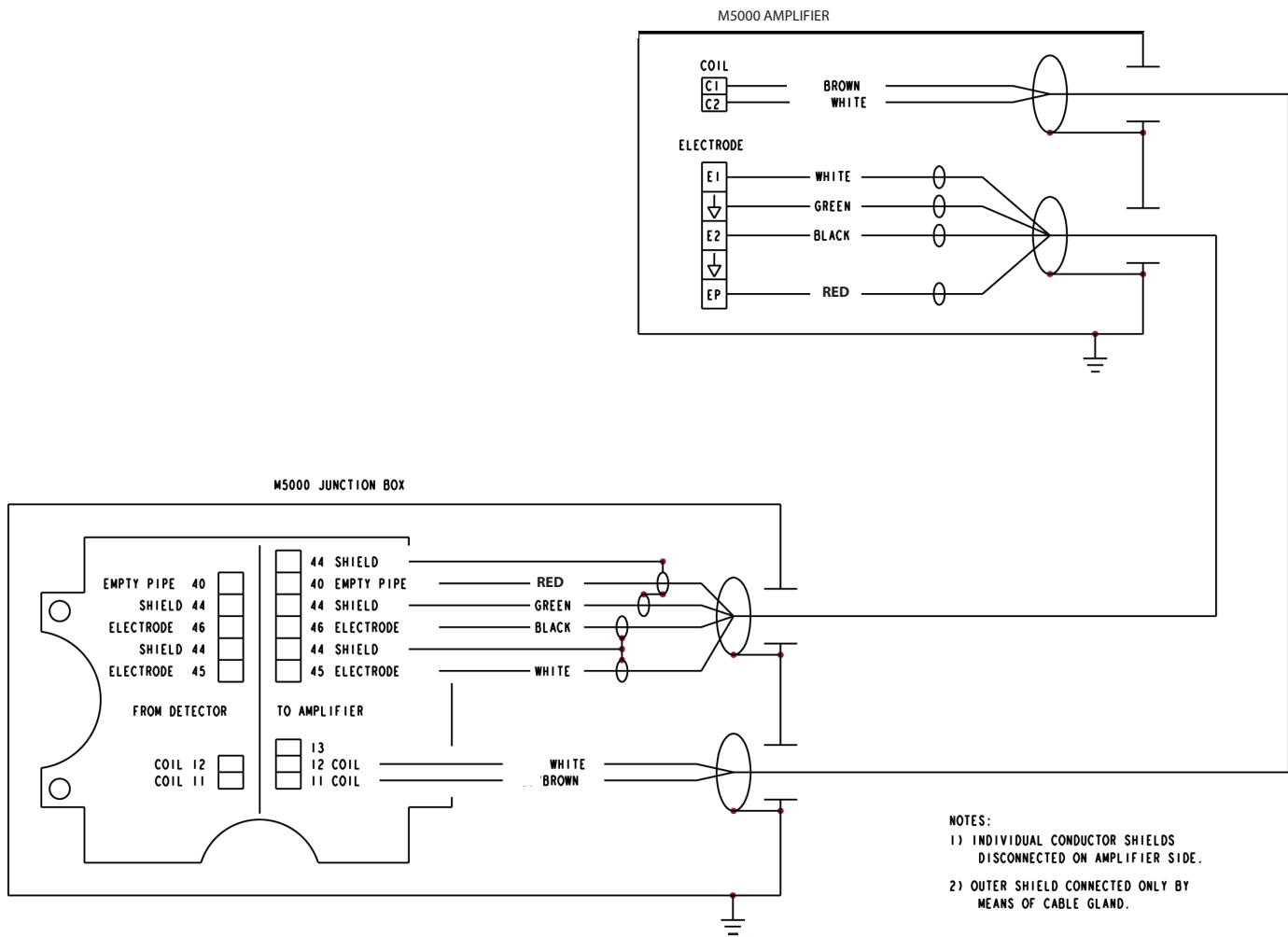

Figure 10: Wiring for remote configuration

Remote style M5000 amplifier models can be ordered with standard cables measuring 15, 30, 50, 100 and 150 feet.

Junction Box		
Connection No.	Description	Wire Color
11	Coil	Brown
12	Coil	White
13	Main Shield	Not Used
40	Empty Pipe	Red
44*	Shield	—
44*	Empty Pipe Shield	Shield Wire
45	Electrode	White
46	Electrode	Black

*Connections with the No. 44 are lying on the same potential.

Control. Manage. Optimize.

ModMAG is a registered trademarks of Badger Meter, Inc. Other trademarks appearing in this document are the property of their respective entities. Due to continuous research, product improvements and enhancements, Badger Meter reserves the right to change product or system specifications without notice, except to the extent an outstanding contractual obligation exists. © 2022 Badger Meter, Inc. All rights reserved.