

# SIEMENS

## SITRANS L

### Ultrasonic level controllers SITRANS LUT400

#### Operating Instructions

7ML5400 (SITRANS LUT400)

04/2021



A5E33329501-AG

<u>Introduction</u>	<b>1</b>
<u>Safety Notes</u>	<b>2</b>
<u>Description</u>	<b>3</b>
<u>Installing and Mounting</u>	<b>4</b>
<u>Connecting</u>	<b>5</b>
<u>Commissioning</u>	<b>6</b>
<u>General Operation</u>	<b>7</b>
<u>Remote Operation</u>	<b>8</b>
<u>Parameter reference (LUI)</u>	<b>9</b>
<u>Service and Maintenance</u>	<b>10</b>
<u>Diagnosing and Troubleshooting</u>	<b>11</b>
<u>Technical data</u>	<b>12</b>
<u>Dimension drawings</u>	<b>13</b>
<u>Technical reference</u>	<b>A</b>
<u>Product documentation and support</u>	<b>B</b>
<u>List of abbreviations</u>	<b>C</b>
<u>LCD menu structure</u>	<b>D</b>

## Legal information

### Warning notice system

This manual contains notices you have to observe in order to ensure your personal safety, as well as to prevent damage to property. The notices referring to your personal safety are highlighted in the manual by a safety alert symbol, notices referring only to property damage have no safety alert symbol. These notices shown below are graded according to the degree of danger.

 <b>DANGER</b>
indicates that death or severe personal injury <b>will</b> result if proper precautions are not taken.
 <b>WARNING</b>
indicates that death or severe personal injury <b>may</b> result if proper precautions are not taken.
 <b>CAUTION</b>
indicates that minor personal injury can result if proper precautions are not taken.
<b>NOTICE</b>
indicates that property damage can result if proper precautions are not taken.

If more than one degree of danger is present, the warning notice representing the highest degree of danger will be used. A notice warning of injury to persons with a safety alert symbol may also include a warning relating to property damage.

### Qualified Personnel

The product/system described in this documentation may be operated only by **personnel qualified** for the specific task in accordance with the relevant documentation, in particular its warning notices and safety instructions. Qualified personnel are those who, based on their training and experience, are capable of identifying risks and avoiding potential hazards when working with these products/systems.

### Proper use of Siemens products

Note the following:

 <b>WARNING</b>
Siemens products may only be used for the applications described in the catalog and in the relevant technical documentation. If products and components from other manufacturers are used, these must be recommended or approved by Siemens. Proper transport, storage, installation, assembly, commissioning, operation and maintenance are required to ensure that the products operate safely and without any problems. The permissible ambient conditions must be complied with. The information in the relevant documentation must be observed.

### Trademarks

All names identified by ® are registered trademarks of Siemens AG. The remaining trademarks in this publication may be trademarks whose use by third parties for their own purposes could violate the rights of the owner.

### Disclaimer of Liability

We have reviewed the contents of this publication to ensure consistency with the hardware and software described. Since variance cannot be precluded entirely, we cannot guarantee full consistency. However, the information in this publication is reviewed regularly and any necessary corrections are included in subsequent editions.

# Table of contents

<b>1</b>	<b>Introduction</b>	<b>13</b>
1.1	The Manual	13
1.1.1	Manual symbols	13
1.1.2	Application examples	14
1.2	Change History	14
1.2.1	Sensor node	14
1.2.2	LUI	14
1.3	Security information	15
<b>2</b>	<b>Safety Notes</b>	<b>16</b>
2.1	Safety marking symbols	16
2.2	FCC Conformity	17
2.2.1	CE Electromagnetic Compatibility (EMC) Conformity	17
<b>3</b>	<b>Description</b>	<b>19</b>
3.1	Features	19
3.2	Models	20
3.3	Applications	20
3.4	Approvals and Certificates	20
<b>4</b>	<b>Installing and Mounting</b>	<b>21</b>
4.1	Mounting locations	21
4.2	Mounting instructions	22
4.2.1	Wall or panel mount	22
4.2.1.1	Remote mounted lid	24
4.2.1.2	Mounting the remote lid	25
4.2.2	Pipe mount	26
4.2.2.1	Mounting the enclosure	27
4.2.3	DIN-rail mount	28
4.2.3.1	Mounting the enclosure	29
4.2.3.2	Removing the enclosure	29
4.2.4	Preparation for cable entry	29
4.2.4.1	Cable routed through conduit	29
4.2.4.2	Cable exposed and entering through the cable glands	30
4.3	SITRANS LUT400 wiring compartment	31
4.4	The Battery	31
<b>5</b>	<b>Connecting</b>	<b>32</b>
5.1	Connecting SITRANS LUT400	34
5.1.1	Wiring compartment	35
5.1.2	Power	35

5.1.3	Cables .....	38
5.1.4	Transducers .....	38
5.1.5	Temperature sensor .....	39
5.1.6	Relays .....	40
5.1.7	Communications .....	41
5.1.7.1	Connecting via USB .....	41
5.1.7.2	Connecting HART .....	43
5.1.8	Level system synchronization .....	44
5.1.9	Discrete inputs .....	45
5.1.10	Remote mounted lid with extension cable .....	46
5.1.11	Extension cable .....	48
5.2	Connecting in hazardous area installations .....	49
<b>6</b>	<b>Commissioning .....</b>	<b>50</b>
6.1	Local Commissioning .....	50
6.2	Activating SITRANS LUT400 .....	51
6.2.1	The LCD Display .....	52
6.2.1.1	Measurement mode display: Normal operation .....	52
6.2.1.2	PROGRAM mode display .....	53
6.2.1.3	Key functions in Measurement mode .....	54
6.2.2	Programming SITRANS LUT400 .....	54
6.3	Quick Start Wizards .....	58
6.3.1	Quick Start Wizards via LUI .....	59
6.3.1.1	Quick Start .....	59
6.3.1.2	QS Volume .....	63
6.3.1.3	QS Flow .....	68
6.3.1.4	Pump Control .....	75
6.4	Accuracy .....	78
6.5	Requesting an Echo Profile .....	78
6.6	Device Address .....	79
6.7	Testing the configuration .....	79
6.8	Application examples .....	79
6.8.1	Level Application Example .....	79
6.8.2	Flow application example .....	80
6.8.2.1	Parshall Flume .....	80
<b>7</b>	<b>General Operation .....</b>	<b>83</b>
7.1	Starting measurement .....	83
7.1.1	Measurement conditions .....	83
7.1.1.1	Response Rate .....	83
7.1.1.2	Dimensions .....	84
7.1.1.3	Fail-safe .....	84
7.2	Relays .....	84
7.2.1	General introduction .....	85
7.2.2	Relay function .....	86
7.2.2.1	Alarm .....	86
7.2.2.2	Pump .....	87
7.2.2.3	Miscellaneous .....	87

7.2.3	Relay behaviour under fail-safe conditions.....	87
7.2.3.1	Alarm relays.....	87
7.2.3.2	Pump relays.....	88
7.2.3.3	Miscellaneous relays.....	88
7.2.4	Relay states.....	89
7.2.4.1	Relay output logic.....	89
7.2.4.2	Relay related parameters.....	89
7.2.5	Relays controlled by HART Communications.....	91
7.3	Discrete Inputs.....	91
7.3.1	Backup Level Override.....	91
7.3.1.1	Basic operation.....	92
7.3.1.2	Backup Level Override parameters.....	92
7.3.1.3	Level Override conditions.....	92
7.3.1.4	Effect of Backup Level Override.....	93
7.3.1.5	Additional considerations.....	93
7.3.2	Pump Interlocks.....	93
7.3.3	Switch (DI) Alarm.....	93
7.3.4	Discrete Input Logic.....	93
7.4	mA Control.....	94
7.4.1	mA output.....	94
7.4.2	Verifying the mA range.....	95
7.5	Volume.....	95
7.5.1	Readings.....	95
7.5.2	Vessel Shape and Dimensions.....	95
7.5.3	Characterization chart.....	97
7.5.3.1	Example chart (with 15 of possible 32 Level and Volume breakpoints defined):.....	97
7.6	Alarms.....	99
7.6.1	Set the common parameters.....	99
7.6.2	Level.....	100
7.6.3	In-bounds/ Out-of-bounds Range.....	100
7.6.3.1	Example: Setting an In-bounds Level Alarm.....	100
7.6.3.2	Example: Setting an Out-of-bounds Level Alarm.....	101
7.6.4	Temperature.....	101
7.6.5	Switch (Discrete Input) Alarm.....	102
7.6.6	Fail-safe Fault Alarm.....	102
7.6.7	Flowrate.....	102
7.7	Pump Control.....	103
7.7.1	Pump Control options.....	103
7.7.1.1	Pump Control algorithms.....	103
7.7.2	Setting a pump down (wet well) group.....	104
7.7.2.1	Set the common parameters.....	105
7.7.2.2	Set Relays to ALTERNATE DUTY ASSIST (ADA).....	105
7.7.2.3	Set the ON Setpoints.....	105
7.7.2.4	Set the OFF Setpoints.....	106
7.7.3	Other Pump Control algorithms.....	106
7.7.3.1	Set Relays to ALTERNATE DUTY BACKUP (ADB).....	106
7.7.3.2	Set Relays to FIXED DUTY ASSIST (FDA).....	107
7.7.3.3	Set Relays to FIXED DUTY BACKUP (FDB).....	107
7.7.3.4	Set Relays to SERVICE RATIO DUTY ASSIST (SRA).....	108
7.7.3.5	Set Relays to SERVICE RATIO DUTY BACKUP (SRB).....	109

7.7.4	Setting a pump up (reservoir) group .....	111
7.7.4.1	Set the common parameters .....	111
7.7.4.2	Set Relays to ALTERNATE DUTY ASSIST (ADA) .....	112
7.7.4.3	Set the ON Setpoints.....	112
7.7.4.4	Set the OFF Setpoints .....	112
7.7.5	Pump Control Interlocks.....	113
7.7.6	Other Pump Controls .....	114
7.7.6.1	Totalizing pumped volume.....	114
7.7.6.2	Setting a pump to run-on.....	115
7.7.6.3	Setting the pump start delays.....	115
7.7.6.4	Reducing wall cling .....	115
7.7.6.5	Saving energy.....	116
7.7.6.6	Tracking pump usage.....	117
7.8	Other controls .....	118
7.8.1	Relays controlled by time .....	118
7.9	Flow .....	119
7.9.1	Flow calculation .....	119
7.9.2	Totalizing flow.....	119
7.10	External Totalizers and Flow Samplers.....	120
7.10.1	Relay contacts.....	120
7.10.2	Totalizer .....	121
7.10.3	Flow Sampler.....	122
7.11	Open Channel Monitoring (OCM).....	123
7.11.1	Method of Flow Calculation .....	124
7.11.2	Common parameters .....	124
7.11.3	Setting Zero Head.....	125
7.11.4	PMDs with Exponential Flow to Head function .....	126
7.11.4.1	Standard Weirs .....	126
7.11.4.2	Applicable weir profiles.....	126
7.11.4.3	Parshall Flume .....	128
7.11.4.4	Leopold Lagco Flume .....	129
7.11.4.5	Cut Throat Flume.....	130
7.11.4.6	Khafagi Venturi.....	131
7.11.4.7	Universal calculation support .....	149
7.11.4.8	Typical flow characterization.....	150
7.11.4.9	Example flumes .....	151
7.11.4.10	Example weirs .....	152
7.12	Trends.....	153
7.13	Data logging.....	154
7.13.1	Viewing the Data Log.....	154
7.14	Simulation .....	155
7.14.1	Pump relay behaviour during simulation .....	156
7.14.2	Fail-safe and Simulation.....	157
7.14.3	HART status .....	157
7.14.4	Simulation process .....	157
7.14.4.1	Simulating a fixed level.....	158
7.14.4.2	Simulating a changing level .....	158
7.14.4.3	Simulating Discrete Inputs .....	158
7.14.4.4	Simulation timeout.....	159

7.14.5	Application test.....	159
7.15	SITRANS LUT400 Communication Systems .....	160
7.15.1	LUT400 Communications (HART) .....	160
7.15.1.1	HART Version.....	160
7.15.1.2	Burst mode.....	160
7.15.1.3	HART multi-drop mode.....	161
7.15.1.4	SIMATIC PDM.....	161
7.15.1.5	HART Electronic Device Description (EDD) .....	161
7.15.1.6	HART Status.....	161
7.15.2	LUT400 Communication connections .....	161
7.15.3	Configuring communication ports.....	162
7.15.3.1	HART modem .....	162
7.15.3.2	USB cable .....	162
7.15.4	Communication troubleshooting.....	163
<b>8</b>	<b>Remote Operation .....</b>	<b>164</b>
8.1	Operation via SIMATIC PDM 6 (HART) .....	164
8.1.1	Startup and Configuration.....	165
8.1.1.1	SIMATIC PDM version.....	165
8.1.1.2	Electronic Device Description (EDD) .....	165
8.2	Operation via Web Browser (USB).....	166
8.2.1	Features and Functions.....	166
8.2.2	Startup and Configuration.....	166
8.3	Operation via AMS Device Manager (HART) .....	167
8.3.1	Features and Functions.....	167
8.3.2	Startup and Configuration.....	167
8.3.2.1	Electronic Device Description (EDD) .....	168
8.4	Operation via Field Communicator 375/475 (FC375/ .....	168
8.4.1	Features and Functions.....	168
8.4.2	Startup and Configuration.....	168
8.5	Operation via FDT (Field Device Tool) .....	169
8.5.1	Features and Functions.....	169
8.5.2	Startup and Configuration.....	169
8.5.2.1	Device Type Manager (DTM) .....	169
8.5.2.2	SITRANS DTM version 3.1 .....	169
8.5.2.3	Electronic Device Description (EDD) .....	170
<b>9</b>	<b>Parameter reference (LUI) .....</b>	<b>171</b>
9.1	Wizards (1.) .....	172
9.2	Setup (2.) .....	172
9.2.1	Sensor (2.1).....	172
9.2.1.1	Units (2.1.1.) .....	172
9.2.1.2	Sensor Mode (2.1.2.) .....	173
9.2.1.3	Sensor Mode (2.1.3.) .....	173
9.2.1.4	Sensor Mode Secondary (2.1.4.) .....	174
9.2.1.5	Sensor Mode Secondary (2.1.5.) .....	174
9.2.1.6	Transducer (2.1.6.) .....	174
9.2.1.7	Frequency (2.1.7.) .....	175
9.2.1.8	Long Shot Duration (2.1.8.) .....	175

9.2.1.9	Short Shot Duration (2.1.9.).....	175
9.2.2	Calibration (2.2.) .....	176
9.2.2.1	Low Calibration Point (2.2.1.) .....	176
9.2.2.2	High Calibration Point (2.2.2.).....	176
9.2.2.3	Sensor Offset (2.2.3.) .....	176
9.2.2.4	Near Range (2.2.4.) .....	176
9.2.2.5	Far Range (2.2.5.).....	177
9.2.2.6	Auto Sensor Offset (2.2.6.) .....	177
9.2.3	Rate (2.3.) .....	178
9.2.3.1	Fill Rate per Minute (2.3.1.) .....	178
9.2.3.2	Empty Rate per Minute (2.3.2.) .....	178
9.2.3.3	Damping Filter (2.3.3.) .....	178
9.2.4	Fail-Safe (2.4.).....	179
9.2.4.1	Material Level (2.4.1.).....	179
9.2.4.2	LOE Timer (2.4.2.) .....	179
9.2.4.3	Fail-Safe mA Value (2.4.3.) .....	179
9.2.5	Current Output (2.5.).....	180
9.2.5.1	Current Output Function (2.5.1.) .....	180
9.2.5.2	Current Output Function (2.5.2.) .....	180
9.2.5.3	4 mA Setpoint (2.5.3.) .....	182
9.2.5.4	20 mA Setpoint (2.5.4.) .....	182
9.2.5.5	Minimum mA Limit (2.5.5.).....	183
9.2.5.6	Maximum mA Limit (2.5.6.).....	183
9.2.5.7	Manual Value (2.5.7.) .....	183
9.2.5.8	Current Output Value (2.5.8.) .....	183
9.2.6	Volume (2.6.) .....	184
9.2.6.1	Vessel Shape (2.6.1.) .....	184
9.2.6.2	Volume Units (2.6.2.) .....	186
9.2.6.3	Maximum Volume (2.6.3.).....	186
9.2.6.4	Dimension A (2.6.4.).....	186
9.2.6.5	Dimension L (2.6.5.) .....	186
9.2.6.6	User Defined Unit (2.6.6.).....	187
9.2.6.7	Table 1-8 (2.6.7.).....	187
9.2.6.8	Table 9-32 .....	188
9.2.7	Pumps (2.7.).....	189
9.2.7.1	Basic Setup (2.7.1.).....	189
9.2.7.2	Modifiers (2.7.2.).....	192
9.2.7.3	Totalizers (2.7.3.) .....	198
9.2.8	Alarms (2.8.) .....	200
9.2.8.1	High Level Alarm (2.8.1.) .....	200
9.2.8.2	Low Level Alarms (2.8.2.) .....	201
9.2.8.3	Switch (Discrete Input) Alarm (2.8.3.) .....	202
9.2.8.4	In-bounds Level Alarm (2.8.4.) .....	203
9.2.8.5	Out-of-bounds Level Alarm (2.8.5.).....	204
9.2.8.6	Low Temperature Alarm (2.8.6.) .....	205
9.2.8.7	High Temperature Alarm (2.8.7.) .....	206
9.2.8.8	Fail-safe Fault Alarm (2.8.8.).....	207
9.2.8.9	High Flowrate Alarm (2.8.9.).....	208
9.2.8.10	Low Flowrate Alarm (2.8.10.) .....	209
9.2.8.11	Relay Logic (2.8.11.) .....	210
9.2.8.12	Time To Spill (2.8.12.).....	211
9.2.9	Discrete Inputs (2.9.) .....	211



9.2.9.1	Backup Level Override (2.9.1) .....	211
9.2.9.2	Discrete Input Logic (2.9.2) .....	212
9.2.9.3	Pump Interlock (2.9.3) .....	213
9.2.10	Data Logging (2.10.) .....	214
9.2.10.1	Logging Mode (2.10.1.) .....	214
9.2.10.2	Process Value Log (2.10.2.) .....	214
9.2.10.3	Alarm Log (2.10.3.) .....	215
9.2.10.4	Flow Log (2.10.4.) .....	215
9.2.10.5	Delete Logs (2.10.5.) .....	216
9.2.11	Other Control (2.11.) .....	216
9.2.11.1	Elapsed Time Relay (2.11.1.) .....	216
9.2.11.2	Time of Day Relay (2.11.2.) .....	218
9.2.11.3	External Totalizer (2.11.3.) .....	219
9.2.11.4	External Sampler (2.11.4.) .....	220
9.2.12	Signal Processing (2.12.) .....	222
9.2.12.1	Temperature and Velocity (2.12.1.) .....	222
9.2.12.2	Echo Select (2.12.2.) .....	224
9.2.12.3	TVT Setup (2.12.3.) .....	227
9.2.12.4	TVT Shaper (2.12.4.) .....	229
9.2.12.5	Measured Values (2.12.5.) .....	230
9.2.13	Display (2.13.) .....	231
9.2.13.1	Local Display Backlight (2.13.1.) .....	231
9.2.13.2	LCD Contrast (2.13.2.) .....	231
9.2.14	Date and Time (2.14.) .....	232
9.2.14.1	Date (2.14.1.) .....	232
9.2.14.2	Time (2.14.2.) .....	233
9.2.14.3	Daylight Saving (2.14.3.) .....	233
9.2.15	Flow (2.15.) .....	234
9.2.15.1	Primary Measuring Device (PMD) (2.15.1.) .....	234
9.2.15.2	Auto Zero Head (2.15.2.) .....	235
9.2.15.3	Basic Setup (2.15.3.) .....	235
9.2.15.4	PMD Dimensions (2.15.4.) .....	239
9.2.15.5	Universal Head versus Flow (2.15.5.) .....	241
9.2.16	Totalizers (2.16.) .....	242
9.2.16.1	Daily Totalizer (2.16.1.) .....	242
9.2.16.2	Running Totalizer (2.16.2.) .....	242
9.2.16.3	Totalizer Decimal Position (2.16.3.) .....	243
9.2.16.4	Totalizer Multiplier (2.16.4.) .....	243
9.2.16.5	Reset Daily Totalizer (2.16.5.) .....	243
9.2.16.6	Reset Running Totalizer (2.16.6.) .....	243
9.3	Maintenance and Diagnostics (3.) .....	244
9.3.1	Identification (3.1.) .....	244
9.3.1.1	TAG (3.1.1.) .....	244
9.3.1.2	Long TAG (3.1.2.) .....	244
9.3.1.3	Descriptor (3.1.3.) .....	244
9.3.1.4	Message (3.1.4.) .....	244
9.3.1.5	Installation Date (3.1.5.) .....	244
9.3.1.6	Product (3.1.6.) .....	245
9.3.1.7	Order No. (Order Number in PDM) (3.1.7.) .....	245
9.3.1.8	Serial Number (3.1.8.) .....	245
9.3.1.9	Final Assembly Number (3.1.9.) .....	245
9.3.1.10	Hardware Revision (3.1.10.) .....	245

9.3.1.11	Firmware Revision (3.1.11.)	245
9.3.1.12	Loader Revision (3.1.12.)	245
9.3.1.13	Manufacture Date (Date of Manufacturing in PDM) (3.1.13.)	245
9.3.1.14	Order Option (3.1.14.)	245
9.3.2	Diagnostics (3.2.)	246
9.3.2.1	Echo Profile (3.2.1.)	246
9.3.2.2	Trend (3.2.2.)	246
9.3.2.3	Master Reset (3.2.3.)	247
9.3.2.4	Power-on Resets (3.2.4.)	247
9.3.2.5	Power-on Time (3.2.5.)	247
9.3.2.6	View Logs (3.2.6.)	247
9.3.2.7	Pump Records (3.2.7.)	248
9.3.2.8	Temperature Peak Values (3.2.8.)	249
9.3.2.9	Echo Quality (3.2.9.)	249
9.3.3	Maintenance (3.3.)	250
9.3.3.1	Transducer Enable (3.3.1.)	250
9.3.3.2	Backup Control (3.3.2.)	251
9.3.3.3	Remaining Device Life (3.3.3.)	251
9.3.3.4	Remaining Sensor Life (3.3.4.)	254
9.3.3.5	Service Schedule (3.3.5.)	257
9.3.3.6	Schedule (3.3.6.)	260
9.3.4	Simulation (3.4.)	262
9.3.4.1	Level (3.4.1.)	263
9.3.4.2	Discrete Inputs (3.4.2.)	263
9.3.4.3	Pump Activations (3.4.3.)	264
9.4	Communication (4.)	264
9.4.1	Device Address (4.1.)	264
9.5	Security (5.)	265
9.5.1	Write Protection (5.1.)	265
9.5.2	User PIN (5.2.)	266
9.6	Language (6.)	266
<b>10</b>	<b>Service and Maintenance</b>	<b>267</b>
10.1	Firmware updates	267
10.2	Transferring parameters using LUT400 display lid	267
10.3	Replacing the Battery	268
10.4	Disposal	269
10.5	Return of products with lithium batteries	269
10.6	Return procedure	269
<b>11</b>	<b>Diagnosing and Troubleshooting</b>	<b>271</b>
11.1	Communication Troubleshooting	271
11.1.1	Generally	271
11.1.2	Specifically	271
11.2	Device Status Icons	272
11.3	General Fault Codes	273
11.4	Common Problems Chart	276

11.5	Noise Problems .....	280
11.5.1	Determine the Noise Source.....	280
11.5.1.1	Acoustical Noise .....	281
11.5.2	Non-Transducer Noise Sources.....	281
11.5.3	Common Wiring Problems.....	282
11.5.4	Reducing Electrical Noise .....	282
11.5.5	Reducing Acoustical Noise .....	282
11.6	Measurement Difficulties .....	282
11.6.1	Loss of Echo (LOE) .....	283
11.6.1.1	LOE occurs when: .....	283
11.6.1.2	If 2.4.3. Fail-Safe mA Value is displayed, check the following:.....	283
11.6.2	Adjust Transducer Aiming .....	283
11.6.3	Increase Fail-safe Timer Value .....	283
11.6.4	Install a Transducer with a Narrower Beam.....	284
11.7	Fixed Reading .....	284
11.7.1	Obstructions in the Sound Beam .....	284
11.7.2	Nozzle Mountings.....	284
11.7.3	Set the SITRANS LUT400 to Ignore the Bad Echo.....	285
11.7.3.1	If the Echo is Close to the Transducer .....	285
11.7.3.2	Adjust the TVT to Ignore the Echo .....	285
11.8	Wrong Reading .....	285
11.8.1	Types of Wrong Readings .....	285
11.8.2	Liquid Splashing .....	285
11.8.3	Adjust the Echo Algorithm .....	286
11.9	Transducer Ringing .....	286
11.9.1	Normal Ring Down.....	286
11.9.2	Poor Ring Down .....	287
11.10	Echo Profile Display.....	287
11.11	Trend Display.....	287
<b>12</b>	<b>Technical data.....</b>	<b>288</b>
12.1	Power.....	288
12.2	Performance.....	288
12.3	Interface.....	289
12.4	Mechanical .....	290
12.5	Environmental.....	291
12.6	Approvals .....	291
<b>13</b>	<b>Dimension drawings.....</b>	<b>292</b>
13.1	SITRANS LUT400 Dimensions .....	292
13.2	Cutout Dimensions (for Remote Panel Mount).....	293
<b>A</b>	<b>Technical reference .....</b>	<b>294</b>
A.1	Principles of Operation.....	294
A.1.1	Process Variables .....	294
A.1.2	Transmit Pulse .....	294

A.2	Echo Processing .....	295
A.2.1	Echo Selection .....	295
A.2.1.1	Time Varying Threshold (TVT) .....	295
A.2.1.2	Algorithm .....	296
A.2.1.3	Confidence .....	297
A.2.1.4	Echo Threshold .....	297
A.2.1.5	Figure of Merit.....	297
A.2.2	Measurement Range .....	299
A.2.3	Measurement Response .....	300
A.2.3.1	Damping .....	300
A.3	Analog Output.....	301
A.3.1	Current Output Function (2.5.1.) .....	301
A.3.2	Loss of Echo (LOE) .....	302
A.3.2.1	Fail-safe Mode .....	302
A.4	Distance Calculation .....	302
A.4.1	Sound Velocity.....	303
A.5	Volume Calculation.....	303
A.6	Pump Totalizers .....	305
A.6.1	Inflow/Discharge Adjust .....	305
A.7	Flow Calculation .....	306
A.7.1	Method of Flow Calculation .....	306
A.7.2	Data Logging .....	307
<b>B</b>	<b>Product documentation and support .....</b>	<b>309</b>
B.1	Product documentation .....	309
B.2	Technical support .....	310
<b>C</b>	<b>List of abbreviations .....</b>	<b>311</b>
<b>D</b>	<b>LCD menu structure .....</b>	<b>313</b>
	<b>Glossary .....</b>	<b>324</b>
	<b>Index.....</b>	<b>328</b>

# Introduction

## 1.1 The Manual

This manual will help you set up your SITRANS LUT400 for optimum performance. For other Siemens level measurement manuals, go to: [www.siemens.com/level](http://www.siemens.com/level) ([www.siemens.com/level](http://www.siemens.com/level)), and look under Level Measurement.







---

### Note

- This product is intended for use in industrial areas. Operation of this equipment in a residential area may cause interference to several frequency-based communications.
  - Please follow the installation and operating procedures for a quick, trouble-free installation and to ensure the maximum accuracy and reliability of your SITRANS LUT400.
  - This manual applies to the SITRANS LUT400 series only.
- 

### 1.1.1 Manual symbols

Please note their use carefully.

	Alternating Current
	Direct Current
	Earth (ground) Terminal
	Protective Conductor Terminal
	Caution (refer to instructions)
	No co-axial cable connections

### 1.1.2 Application examples

The application examples used in this manual illustrate typical installations using SITRANS LUT400. As there is often a range of ways to approach an application, other configurations may also apply.

In all examples, substitute your own application details. If the examples do not apply to your application, check the applicable parameter reference for the available options.

## 1.2 Change History

### 1.2.1 Sensor node

Firmware Rev.	PDM EDD Rev.	Date	Changes
1.00.00	1.00.00	August 3, 2012	<ul style="list-style-type: none"> <li>Initial release.</li> </ul>
1.00.01	1.00.01	October 1, 2012	<ul style="list-style-type: none"> <li>Totalizers values are maintained over a power loss.</li> <li>Alarms now trip at or beyond setpoints, instead of just beyond.</li> <li>Alarm log files now contain values in user-selected units. Those units are also logged into files.</li> <li>OCM Totalizer values that appear in data log files now in flow units.</li> </ul>
1.01.00	1.01.00	June 1, 2013	<ul style="list-style-type: none"> <li>Added 'mega-gallons per day' flow unit.</li> </ul>
1.01.01	1.01.01	February 1, 2014	Added Russian, Portuguese and Italian language support.
1.02.00	1.02.00	December 1, 2014	<ul style="list-style-type: none"> <li>Added user changeable password and First In, First Out datalog option.</li> </ul>

### 1.2.2 LUI

Firmware Rev.	Date	Changes
1.00.00	August 3, 2012	Initial release
1.01.00	June 1, 2013	<ul style="list-style-type: none"> <li>Level value or level units are now recorded for an in-bounds level alarm in the alarm log.</li> <li>Correction of flow rate on exponential devices using absolute calculation.</li> </ul>
1.01.01	February 1, 2014	Added Russian, Portuguese and Italian language support.
1.02.00	December 1, 2014	Added user changeable password and First In, First Out datalog option.

## 1.3 Security information

Siemens provides products and solutions with industrial security functions that support the secure operation of plants, systems, machines, and networks.

In order to protect plants, systems, machines and networks against cyber threats, it is necessary to implement – and continuously maintain – a holistic, state-of-the-art industrial security concept. Siemens' products and solutions form one element of such a concept.

Customers are responsible for preventing unauthorized access to their plants, systems, machines and networks. These systems, machines and components should only be connected to the enterprise network or the Internet if and only to the extent necessary and with appropriate security measures (firewalls and/or network segmentation) in place.

You can find more information on protective measures in the area of industrial security by visiting:

<https://www.siemens.com/industrialsecurity>.



Siemens' products and solutions undergo continuous development to make them more secure. Siemens strongly recommends performing product updates as soon as they are available and using only the latest product versions. Use of product versions that are no longer supported, and failure to apply latest updates may increase customer's exposure to cyber threats.

To stay informed about product updates, subscribe to the Siemens Industrial Security RSS Feed under

<https://www.siemens.com/industrialsecurity>.









## Safety Notes

Special attention must be paid to warnings and notes highlighted from the rest of the text by grey boxes.

	<b>WARNING:</b> relates to a caution symbol on the product, and means that failure to observe the necessary precautions can result in death, serious injury, and/or considerable material damage.
	<b>WARNING<sup>1</sup>:</b> means that failure to observe the necessary precautions can result in death, serious injury, and/or considerable material damage.
<b>Note:</b>	Means important information about the product or that part of the operating manual.

<sup>1)</sup>This symbol is used when there is no corresponding caution symbol on the product.

### 2.1 Safety marking symbols

In manual	On product	Description
		Earth (ground) Terminal (shield)
		Protective Conductor Terminal
		Dispose of in an environmentally safe manner, and according to local regulations.
		<b>WARNING:</b> refer to accompanying documents (manual) for details.
		<b>CAUTION:</b> Observe electrostatic discharge precautions prior to handling electronic components within the wiring compartment.



## 2.2 FCC Conformity

### US Installations only: Federal Communications Commission (FCC) rules

---

#### Note

##### Void user authority

Changes or modifications not expressly approved by Siemens could void the user's authority to operate the equipment.

---

#### Note

This equipment has been tested and found to comply with the limits for a Class A digital device, pursuant to Part 15 of the FCC Rules. These limits are designed to provide reasonable protection against harmful interference when the equipment is operated in a commercial environment.

This equipment generates, uses, and can radiate radio frequency energy and, if not installed and used in accordance with the instruction manual, may cause harmful interference to radio communications. Operation of this equipment in a residential area is likely to cause harmful interference to radio communications, in which case the user will be required to correct the interference at his own expense.

---

### 2.2.1 CE Electromagnetic Compatibility (EMC) Conformity

This equipment has been tested and found to comply with the following EMC Standards:

EMC Standard	Title
CISPR 11:2004/EN 55011:2009, CLASS A	Limits and methods of measurements of radio disturbance characteristics of industrial, scientific, and medical (ISM) radio-frequency equipment.
EN 61326-1: 2006 IEC 61326-1: 2005	Electrical Equipment for Measurement, Control and Laboratory Use – Electromagnetic Compatibility.
EN61000-3-2: 2006	Electromagnetic Compatibility (EMC) Part 3-2: Limits for harmonic current emissions (equipment input current $\leq 16A$ per phase).
EN61000-3-3: 2008 A1: 2001 + A2: 2005	Electromagnetic Compatibility (EMC) Part 3-3: Limitation of voltage changes, voltage fluctuations, and flicker in public low voltage supply systems, for equipment with rated current $\leq 16A$ per phase and not subject to conditional connection.
EN61000-4-2:2009	Electromagnetic Compatibility (EMC) Part 4-2: Testing and measurement techniques – Electrostatic discharge immunity test.
EN61000-4-3:2006	Electromagnetic Compatibility (EMC) Part 4-3: Testing and measurement techniques – Radiated, radio-frequency, electromagnetic field immunity test.
EN61000-4-4:2004	Electromagnetic Compatibility (EMC) Part 4-4: Testing and measurement techniques – Electrical fast transient/burst immunity test.
EN61000-4-5:2006	Electromagnetic Compatibility (EMC) Part 4-5: Testing and measurement techniques – Surge immunity test.

EMC Standard	Title
EN61000-4-6:2009	Electromagnetic Compatibility (EMC) Part 4-6: Testing and measurement techniques – Immunity to conducted disturbances, induced by radio-frequency fields.
EN61000-4-8:2010	Electromagnetic Compatibility (EMC) Part 4-8: Testing and measurement techniques – Power frequency magnetic field immunity test.
EN61000-4-11: 2004	Electromagnetic Compatibility (EMC) Part 4-11: Testing and measurement techniques - voltage clips, short interruptions and voltage variations immunity tests.

---

**Note****Operation under special atmospheric conditions**

Ultrasonic measurement requires that the sound wave travel through the atmosphere in a consistent manner. Applications with atmospheric conditions different from air (including, but not limited to gas layer stratification, very high methane or CO<sub>2</sub> concentrations), should be properly assessed to ensure safe reliable use in the event of measurement errors due to sound wave velocity changes. Please contact your local Siemens representative for assistance.

---

## Description

The Siemens SITRANS LUT400 series controllers are compact, single point, long-range ultrasonic controllers for continuous level measurement of liquids, slurries, and solids, and high accuracy monitoring of open channel flow.

The series is compatible with Siemens full line of EchoMax® Transducers, allowing an operating range of 0.3 to 60 meters (dependent on transducer). The SITRANS LUT400 has been coupled with a backlit Local User Interface (LUI) display featuring menu driven programming and a host of wizards for plug and play performance. The LUT400 also features our next generation of Sonic Intelligence®, further strengthening our industry leading measurement performance while improving ease of use. With a number of advanced pump, alarm, and flow control features, plus a real time clock and an integrated datalogger, the LUT400 is a powerful and comprehensive solution for your Ultrasonic applications.

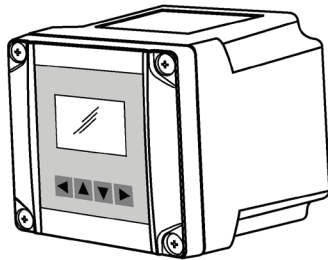

### 3.1 Features

- Small 1/2 DIN enclosure footprint with standard universal mounting bracket for wall, pipe, and DIN rail, plus an optional panel mount
- Easy to use LUI display with local four-button programming, menu-driven parameters, and Wizard support for key applications
- Level, Volume, High Accuracy OCM Flow monitoring
- Three relays combined with a suite of pump, alarm, and relay control features
- HART Communications
- EDDs for SIMATIC PDM, AMS Device Manager, and Field Communicator 375/475, plus DTMs for FDTs (Field Device Tools)
- Integrated web browser for local programming from an intuitive web-based interface
- Two discrete inputs for backup level override and pump interlock functions
- Echo profile and trend views from the local display
- Patented digital receiver for improved performance in electrically noisy applications (close proximity to VSDs)

- Real time clock with daylight savings time supporting an integrated datalogger and energy saving algorithms for minimizing pump operation during high cost energy periods
- Removable terminal blocks for ease of wiring.

## 3.2 Models

The SITRANS LUT400 comes in three different models, depending on the application, level of performance and functionality required:

- SITRANS LUT420 Level Controller - Level or volume measurement, basic pump control functions, and basic data logging capability
- SITRANS LUT430 Pump and Flow Controller - Full suite of advanced control functionality, open channel flow monitoring, and basic data logging capability
- SITRANS LUT440 High Accuracy OCM - Best performance (rated at 1 mm accuracy up to 3 meters), full suite of advanced control functionality, and enhanced data logging capability.

## 3.3 Applications

- Liquids, solids and slurry monitoring in small to large process and storage vessels or outdoor applications (open air)
- Environmental, Mining/Aggregates/Cement, Food & Beverage, and Chemical market applications primarily
- Key sample applications include: wet wells, reservoirs, flumes/weirs, chemical storage, liquid storage, hoppers, crusher bins, dry solids storage.

## 3.4 Approvals and Certificates

The SITRANS LUT400 is available with General Purpose and Hazardous Area approvals. It also has a number of approvals for specialized applications. For details, see chart below.

### Note

The device nameplate lists the approvals that apply to your device.

Application Type	Approval Rating	Valid for:
Non-hazardous	General Purpose	CSA <sup>US/IC</sup> , CE, FM, UL listed, C-TICK
Hazardous	Non-incendive	CSA Class I, Div. 2, Groups A, B, C, D; Class II, Div 2, Groups F, G; Class III <sup>1</sup>

<sup>1</sup>) Not available for devices with remote display.

# Installing and Mounting

---

**Note**

- Installation must only be performed by qualified personnel, and in accordance with local governing regulations.
- This product is susceptible to electrostatic shock. Follow proper grounding procedures.

---

** CAUTION**

- **All field wiring must have insulation suitable for at least 250V.**
- **Hazardous voltages present on transducer terminals during operation.**
- **DC input terminals shall be supplied from a source providing electrical isolation between the input and output, in order to meet applicable safety requirements of IEC 61010-1.**

---

**Note**

- Relay contact terminals are for use with equipment that has no accessible live parts and wiring that has insulation suitable for at least 250 V. The maximum allowable working voltage between adjacent relay contacts shall be 250 V.
  - The non-metallic enclosure does not provide grounding between conduit connections. Use grounding type bushings and jumpers.
- 

## 4.1 Mounting locations

- Device display window is at shoulder level, unless most interaction is through a SCADA system.
- Easy access to local push buttons is provided.
- Cable length requirements are minimized.
- Mounting surface is free from vibration.
- Sufficient room to swing device lid open and have clear access.
- A place for a laptop computer is provided for on-site configuration (optional, as laptop not required for configuration).
- Exposure to direct sunlight. (Provide a sun shield to avoid direct sunlight.).
- Proximity to high voltage/current runs, contactors, SCR or variable frequency motor speed controllers.

## 4.2 Mounting instructions

Mounting instructions differ for wall, pipe, DIN-rail, and remote display panel mount devices. Please follow the specific instructions for your device.

---

### Note

Some electrical codes require use of metal conduit. When routing cable through a conduit, please follow the Cable Routing instructions (Page 29) before mounting the SITRANS LUT400.

---

### 4.2.1 Wall or panel mount

All configurations of the SITRANS LUT400 are shipped with a mounting back plate. SITRANS LUT400 has the option of a lid with a Local User Interface (LUI) display, a remote display for panel mount configuration, or a blank lid. The panel mount model comes with both a LUI display and a blank lid.

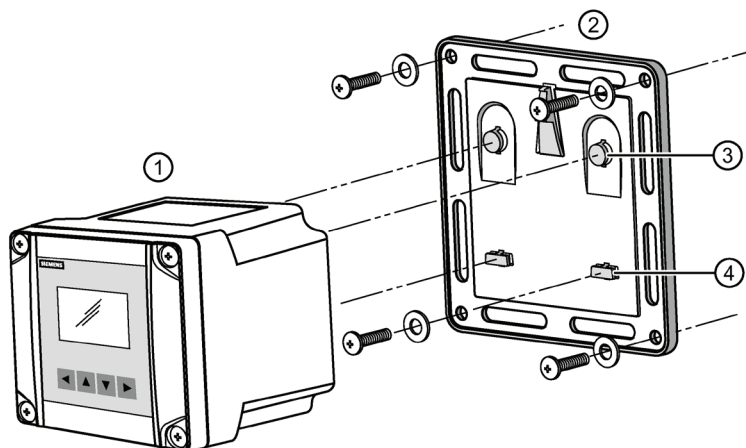

- ① Enclosure with optional display lid
- ② Mounting back plate
- ③ Fasteners
- ④ Clips (2 places)

---

### Note

Wall mount fasteners not included.

---

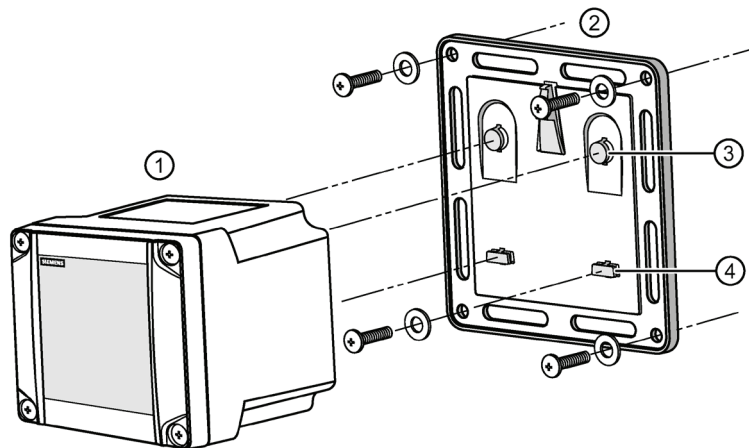

- ① Enclosure with blank lid
- ② Mounting back plate
- ③ Fasteners
- ④ Clips (2 places)

**Note**

Wall mount fasteners not included.

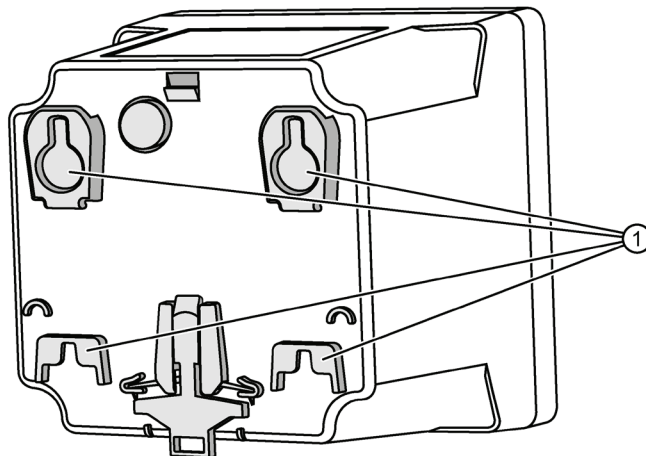

- ① Slotted features

For a more detailed dimension drawing, see SITRANS LUT400 Dimensions (Page 292).

1. Mark and drill four holes in the mounting surface for the four screws (customer supplied).
2. Fasten with a screwdriver.
3. Line up slotted features on back of device with clips on mounting back plate. Press the LUT400 flush against the back plate and slide downward to fasten in place.

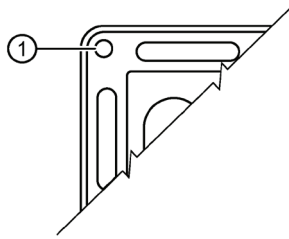

- ① Mounting screw holes on the back plate

**Note**

- Recommended fastener size: M8 or 5/16 " screw with washer of maximum 17 mm or 5/8 " outside diameter.
- Recommended mounting: mount directly to wall. If alternate mounting surface is used, it MUST be able to support four times the weight of the device.

**4.2.1.1 Remote mounted lid**

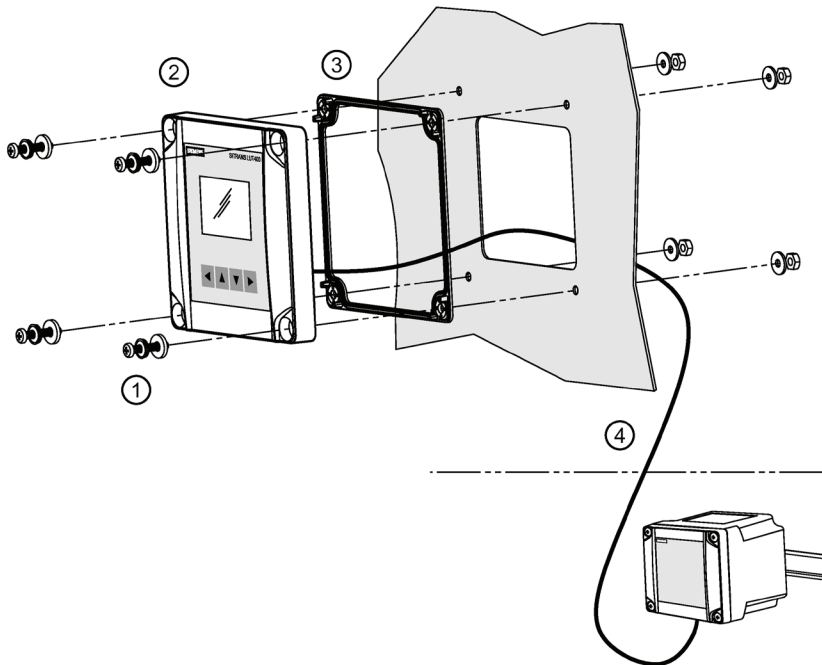

- ① Four panel mount fasteners provided
- ② Remote display lid
- ③ Gasket
- ④ Extension cable

For a more detailed dimension drawing, see SITRANS LUT400 Dimensions (Page 292) and Cutout Dimensions (for Remote Panel Mount) (Page 293).



#### 4.2.1.2 Mounting the remote lid

---

**Note**

Remote mounted lid can be mounted up to 5 m from the device using two optional cable extensions (each 2.5 m in length). For instructions on how to connect an extension cable, see Remote mounted lid with extension cable (Page 46).

---

1. Using the template provided, cut out the necessary hole for the remote LUI display lid. Place the gasket inside the lid, aligning the mounting holes. Align the back of the remote display lid with the panel hole cut-out. Mark and drill four holes in the mounting surface for the four screws (provided).
2. Fasten with a screwdriver and wrench.

---

**Note**

Recommended torque on fastening screws for good seal:

- 1.1 N m
  - 10 in-lbs
- 

---

**Note**

- Recommended mounting: mount to panel, up to 5 m from the device. If alternate mounting surface is used, it MUST be able to support four times the weight of the device.
  - Fasteners included: M5 screw, seal washer, M5 flat washer and nut. These fasteners are required to maintain IP65 rating on remote lid.
-

### 4.2.2 Pipe mount

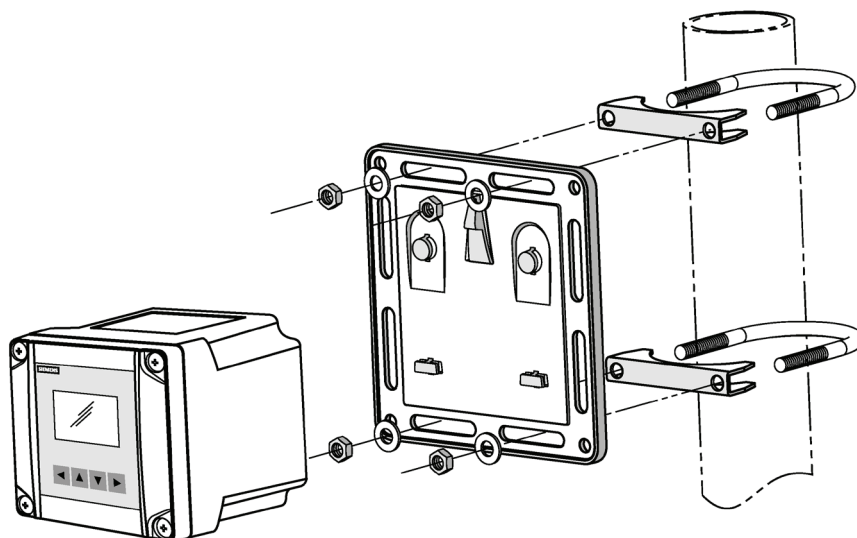

- ① Enclosure with optional display lid
- ② Mounting back plate
- ③ Saddle clamp
- ④ U-bolt
- ⑤ Pipe

---

#### Note

Pipe mount fasteners not included.

---

For a more detailed dimension drawing, see SITRANS LUT400 Dimensions (Page 292) and Cutout Dimensions (for Remote Panel Mount) (Page 293).

#### 4.2.2.1 Mounting the enclosure

1. Fasten the mounting back plate to the pipe using u-bolts, saddle clamps, (customer supplied) suitable to pipe diameter.
2. Fasten bolts with a wrench. Do not over-tighten so that plate becomes twisted or bent. This may hinder ability to clip the LUT400 to the back plate.
3. Fasten device to mounting back plate (as described in step 3 of Wall or panel mount (Page 22)).

---

#### **Note**

- Recommended mounting: directly to horizontal or vertical pipe. If alternate mounting surface is used, it **MUST** be able to support four times the weight of the device.
  - Recommended pipe dimensions: maximum: 3" pipe, minimum: 3/4" pipe.
  - Recommended fastener sizes:
    - U-Bolts:  
Maximum : 3" pipe size with M8 or 3/8" thread.  
Minimum: 3/4" pipe size with M6 or 1/4" thread.
    - Hex Nuts:  
M6 or 1/4" to M8 or 3/8".
    - Washer:  
Maximum: 16 mm or 13/16" outside diameter.
-

### 4.2.3 DIN-rail mount

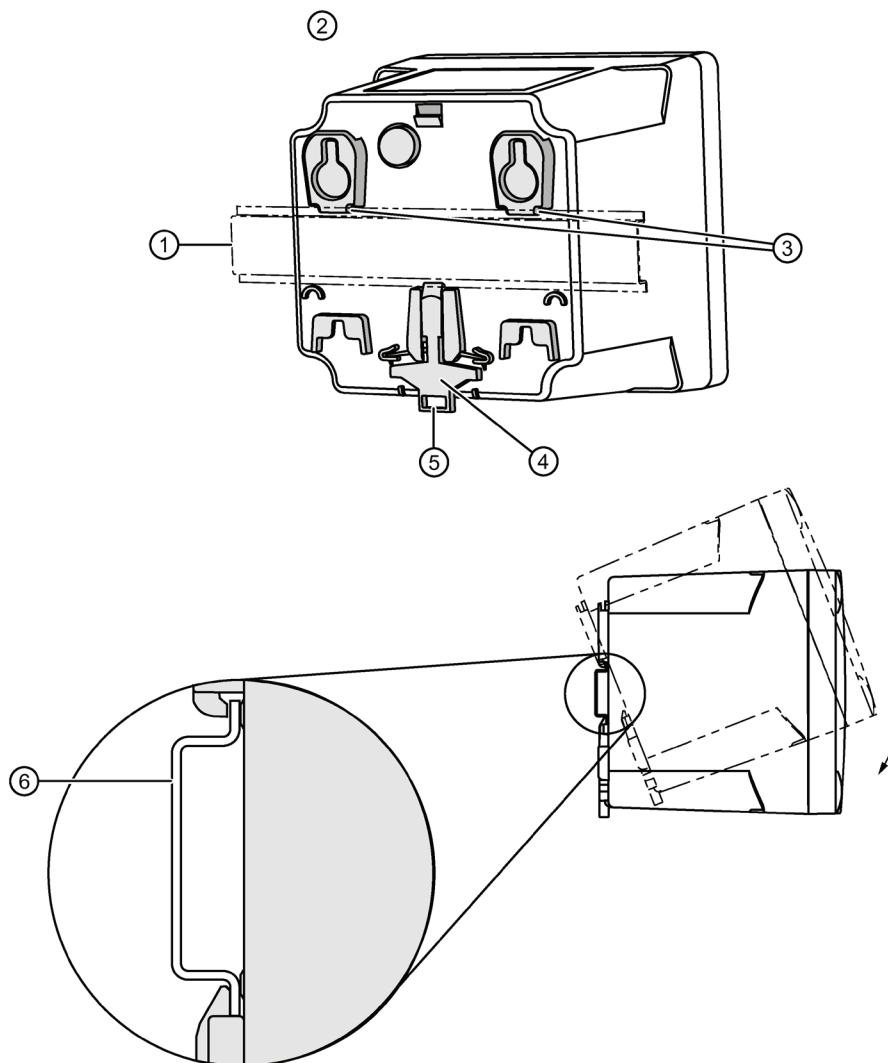

- ① DIN-rail
- ② Back of enclosure
- ③ Clips (2)
- ④ DIN-rail slide
- ⑤ Slot

For a more detailed dimension drawing, see SITRANS LUT400 Dimensions (Page 292).

#### 4.2.3.1 Mounting the enclosure

1. Angle top of enclosure toward DIN-rail, and position slightly above top of rail.
2. Move enclosure downward against DIN-rail to hook clips on back of enclosure to top of DIN-rail.
3. Press device flush against DIN-rail to engage DIN-rail slide, which will fasten enclosure securely to DIN-rail.

---

#### **Note**

Recommended mounting: directly to horizontal DIN-rail.

Required DIN-rail dimensions: TH 35-7.5 or TH 35-15 per standard IEC 60715.

The DIN-rail **MUST** be able to support four times the weight of the SITRANS LUT400.

---

#### 4.2.3.2 Removing the enclosure

1. From the front of the device, place screwdriver in slot at bottom of DIN-rail slide and pry downward. This will unclip slide from bottom of DIN-rail.
2. While holding slide down, push upward on enclosure to release clips from top of DIN-rail.

#### 4.2.4 Preparation for cable entry

Cables can be routed through conduit or enter the enclosure through cable glands. Follow steps 1 to 5 below to first uncover cable entry holes, then complete steps for use with conduit, or with cable glands.

1. Ensure enclosure lid is closed and fastener screws are locked.
2. Place tip of screwdriver into groove on the outer diameter of the knock-out tab (see illustration that follows).
3. Hit the end of the screwdriver with palm of hand to knock out entry hole.
4. Loosen screws and remove enclosure lid.
5. Remove plastic piece(s) that covered entry holes from enclosure. Be careful not to damage the electronics with static electricity, or the tools used to knock out entry holes.

#### 4.2.4.1 Cable routed through conduit

6. After preparing for cable entry in steps 1 to 5 above, attach the conduit to the enclosure using only suitable size fittings approved for water-tight applications. (Conduit size is 1/2" NPT.)
7. Replace enclosure lid and tighten screws.

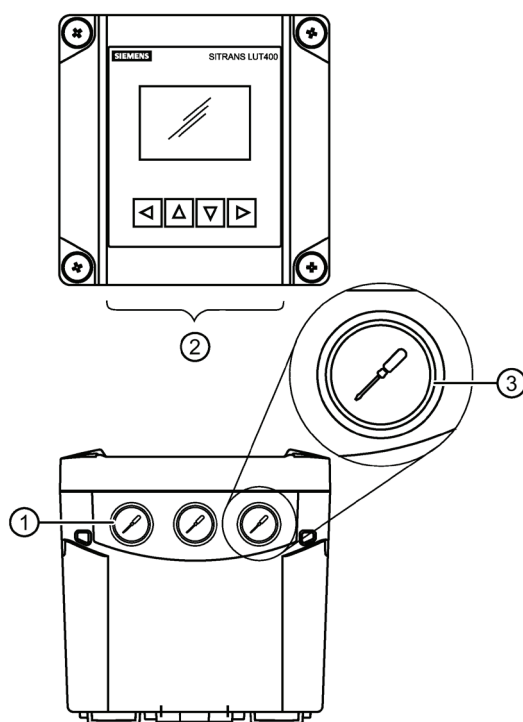

- ① Knock-out tab (3 places)
- ② Cable entry holes
- ③ Groove for screwdriver (3 places)

For a more detailed dimension drawing, see SITRANS LUT400 Dimensions (Page 292).

#### 4.2.4.2 Cable exposed and entering through the cable glands

6. After preparing for cable entry in steps 1 to 5 above, unscrew the glands and attach them firmly to the enclosure.
7. Thread the cables through the glands. Ensure the power cable is kept separated from the signal cables and then wire the cables to the terminal blocks.
8. Tighten the glands to form a good seal.
9. Replace enclosure lid and tighten screws.

---

#### Note

- When cable entry hole knock-out tabs have been removed, the entry hole is 21.4 mm to 21.6 mm in diameter.
  - M20 cable glands (20 mm in diameter), and 1/2" NPT conduit (21.3 mm in diameter) fit this entry hole.
  - Caution should be taken when selecting appropriate seal for entry holes. Flat gasket is recommended (instead of O-ring). If alternate cable glands are used, it is the customer's responsibility to maintain IP65 rating of entry holes.
-

## 4.3 SITRANS LUT400 wiring compartment

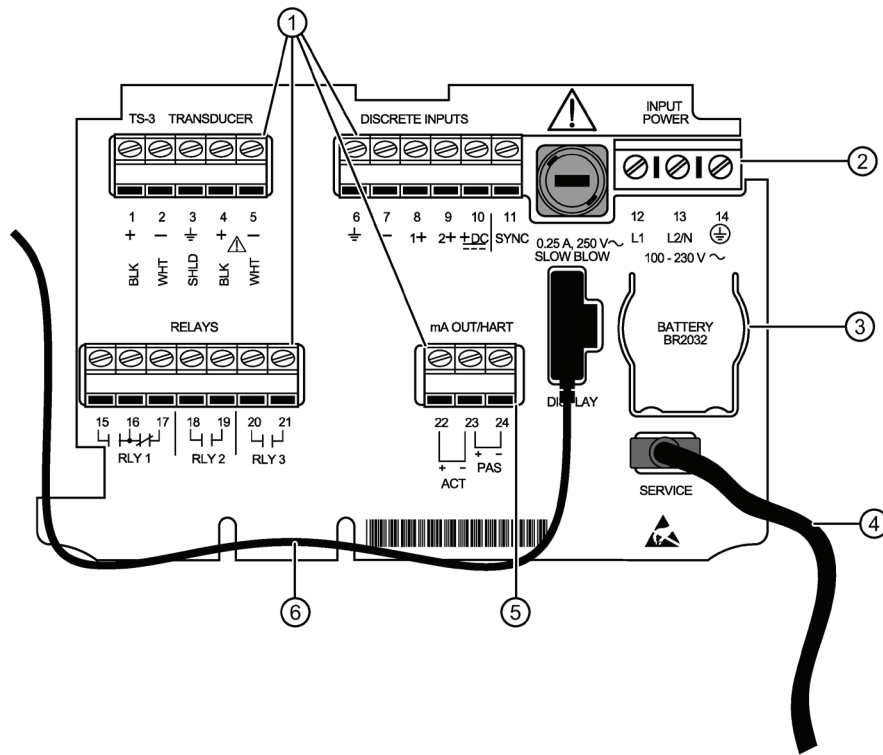

- ① Terminal blocks
- ② Power supply
- ③ Battery
- ④ USB connection
- ⑤ mA HART connection
- ⑥ Display cable

## 4.4 The Battery

The SITRANS LUT400 is supplied with one battery installed. The battery (BR2032) has a life expectancy of ten years, and is affected by ambient temperature. If the LUT400 loses input power, the battery will maintain operation of the device's real time clock until power has been restored.

When the battery reaches its end of life, refer to Replacing the Battery (Page 268).

<p><b>⚠ CAUTION</b></p> <p><b>Disconnect power before replacing the battery.</b></p>
--

## Connecting

- Verify that all system components are installed in accordance with instructions.
- Connect all cable shields to the LUT400 shield terminals (denoted on device with symbol  $\perp$ ). To avoid differential ground potentials ensure cable shields are properly connected to ground.
- Keep exposed conductors on shielded cables as short as possible to reduce noise on the line caused by stray transmissions and noise pickup.



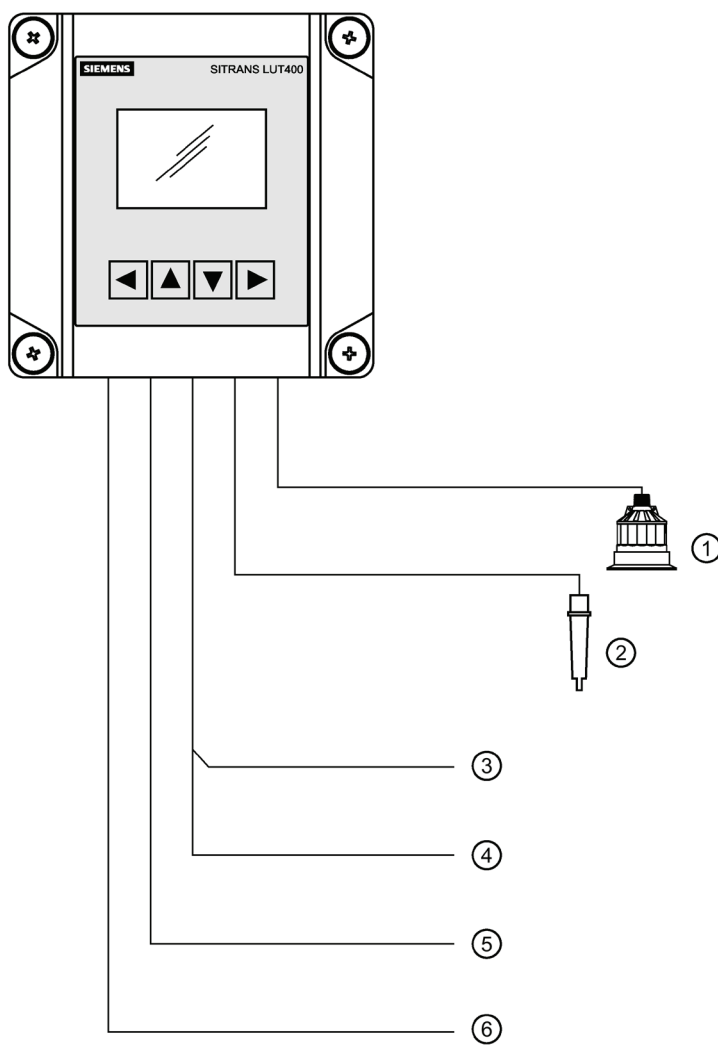

- ① Siemens Transducer
- ② Siemens TS-3 Temperature Sensor
- ③ HART FC375/475 or a computer running SIMATIC PDM, AMS Device Manager, FDT, or a web browser
- ④ Customer Alarm, Pump, or Control Device
- ⑤ Customer Device with Digital Output
- ⑥ Display, PLC, Chart recorder, or other Control Device

## 5.1 Connecting SITRANS LUT400

**⚠ CAUTION**

- Check the device label on your instrument, to verify the approval rating.
- Use appropriate conduit seals to maintain IP or NEMA rating.

**Note**

Separate cables and conduits may be required to conform to standard instrumentation wiring practices or electrical codes.

To access the wiring compartment:

1. Loosen 1/4 turn locking screws.
2. Lift lid up and to the left on its hinges.
3. The lid can remain open connected by hinges, or it can be unclipped from the hinges and set to one side, to access wiring compartment.

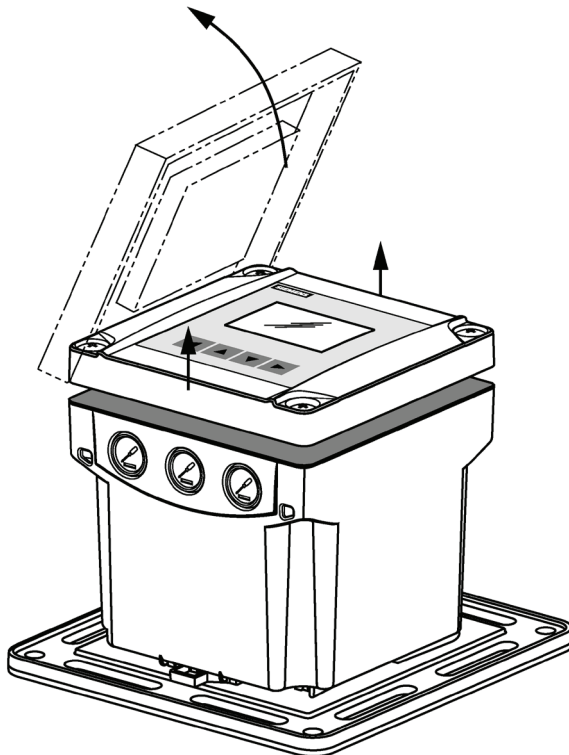

4. Make all connections as per instructions that follow.
5. When wiring complete, replace device lid.
6. Tighten locking screws.

### 5.1.1 Wiring compartment

The terminal board on the LUT400 allows all inputs and outputs to be connected simultaneously. Terminal strips can be removed to improve ease of wiring.

 **CAUTION**

Ensure the terminal strips are terminated to the correct location during re-installation. Failure to do so may result in damage to the device, or external equipment that is attached.

**Note**

Recommended torque on terminal clamping screws.

- 0.56 - 0.79 N m
- 5 - 7 in-lbs

Please do not overtighten the screws.

### 5.1.2 Power

 **WARNING**

**Connection notes**

- The DC input terminals shall be supplied from a source providing electrical isolation between the input and output, in order to meet the applicable safety requirements of IEC 61010-1.
- All field wiring must have insulation ratings suitable for the application.
- Before applying power to the SITRANS LUT400 for the first time, ensure any connected alarm/control equipment is disabled until satisfactory system operation and performance is verified.

5.1 Connecting SITRANS LUT400

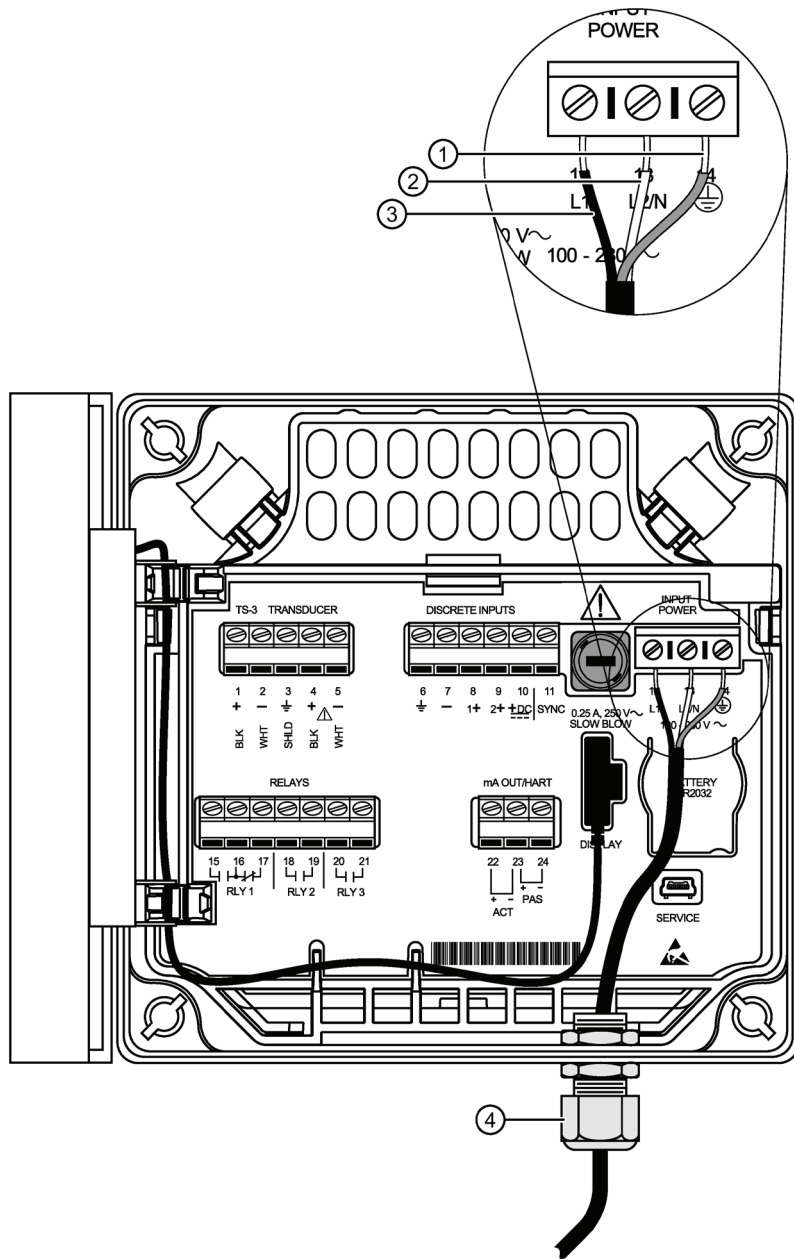

- ① Ground
- ② L2/N
- ③ L1
- ④ Cable gland (or NPT cable entry)

The SITRANS LUT400 is available in AC or DC power models.

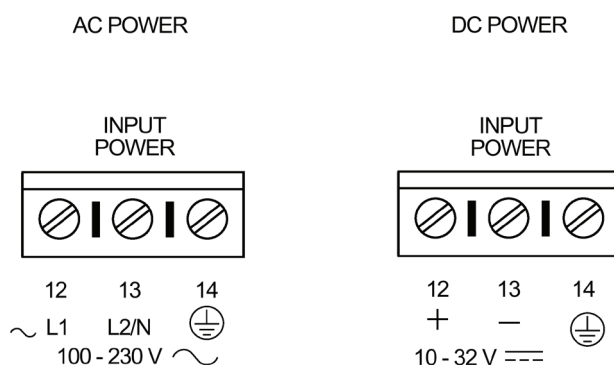

AC: 100-230 V AC 15%, 50/60 Hz, 36 VA (10W) DC: 10-32 V DC, 10W

---

### Note

Make sure device is connected to a reliable ground.

---

1. To wire for power, strip the cable jacket for approximately 70 mm (2.75") from the end of the cable, and thread the wires through the gland<sup>1</sup>
2. Connect the wires to the terminals as shown: the polarity is identified below the terminal block.
3. Ground the device according to local regulations.

<sup>1)</sup> If cable is routed through conduit, use only approved suitable-size hubs for waterproof applications.

---



### Note

#### For AC power connections:

- The equipment must be protected by a 15 A fuse, or circuit breaker on all current-carrying conductors in the building installation.
  - A circuit breaker or switch in the building installation, marked as the disconnect switch, must be in close proximity to the equipment and within easy reach of the operator, and must disconnect all current-carrying conductors.
-

### 5.1.3 Cables

The SITRANS LUT400 is designed to work with two conductor shielded transducer cables.

Connection	Cable Type
mA output, sync, Temperature sensor, discrete input	2 copper conductors, twisted, with shield <sup>1)</sup> /drain wire, 300V 0.324 -0.823 mm <sup>2</sup> (22 - 18 AWG). <b>Maximum length: 365 m</b>
Transducer	Shielded two-wire. Maximum length: 365 m
	
Relay output AC input	Copper conductors per local requirements.

1) Preferred shielding is braided shield.

#### WARNING

##### Coaxial transducer cable extension

Do not use a coaxial transducer cable extension with the SITRANS LUT400. High voltage transmitted on shield of coaxial cable could result in personal injury, damage to equipment, or poor device performance.

### 5.1.4 Transducers

#### WARNING

##### Hazardous voltage

Hazardous voltage present on transducer terminals during operation.

#### Note

- Do not connect coaxial cable directly to SITRANS LUT400 due to high voltage transmitted on shield of coaxial cable.
- Do not connect the LUT400 shield and white transducer wires together; wire to separate terminals.
- Disregard older transducer manuals that recommend these practices.

**Note**

The SITRANS LUT400 supports several different transducers. Some, like the XPS-30, are driven by a low power level, while others, like the XPS-15, are driven by a high power level. It may be possible to damage a lower power transducer like the XPS-30 if the transducer selection is currently set to one of the high power transducers. Follow the steps below to avoid this possibility:

1. Set the transducer selection to No Transducer before powering down the LUT400.
2. Connect the new transducer.
3. Power up the LUT400 and select the correct transducer. This way, the transducer will not be driven with the wrong power level, even for the short period of time until the correct selection is made.

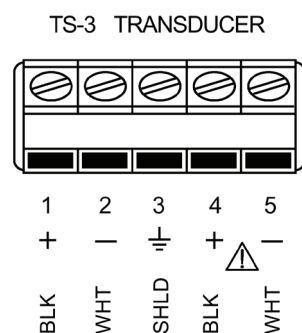

### 5.1.5 Temperature sensor

The speed of sound changes as temperature changes. To ensure accurate level measurement, the SITRANS LUT400 compensates via an external temperature input. All Siemens EchoMax transducers have an internal temperature sensor for this purpose, and for the fastest temperature response, Siemens also offers a dedicated temperature sensor, the TS-3.

If the following conditions apply, a separate TS-3 temperature sensor will ensure optimum accuracy:

- The transducer is exposed to direct sunlight (or other radiant heat source).
- The temperature of the atmosphere between the transducer face and monitored surface differs from the temperature of the transducer.
- Faster response to temperature changes is required.

To achieve the best performance of temperature measurement in a typical open channel flow application, the temperature sensor should be shielded from direct sunlight and mounted half way between the ultrasonic transducer face and the maximum head achievable in the application. Care should be taken to not obstruct the direct sound path of the ultrasonic transducer.

**Note**

Use a TS-3 Temperature Sensor only. Leave terminals open (unused) if TS-3 is not deployed.

**5.1.6 Relays**

Relay contacts are shown in the de-energized position. All relays can be configured as positive or negative logic (see 2.8.11. Relay Logic (Page 210)).

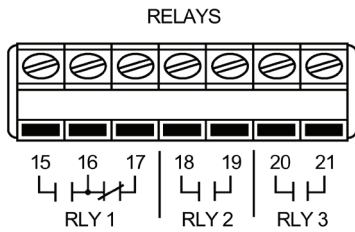

**Power Failure**

Relays 2, 3 are normally open.

Relay 1 can be wired either normally open or normally closed. In the event of loss of input power, relays will revert to their normal states.

**Relay Ratings**

- One Form C (NO or NC) relay (relay 1), 1A at 250 V AC, non-inductive, 3A at 30 V DC.
- Two Form A (NO) relays (relays 2,3), 5A at 250 V AC, non-inductive, 3A at 30 V DC.



## 5.1.7 Communications

The USB port and the 4 to 20 mA HART terminal block (terminal numbers 22, 23, and 24) are located inside the enclosure of the device.

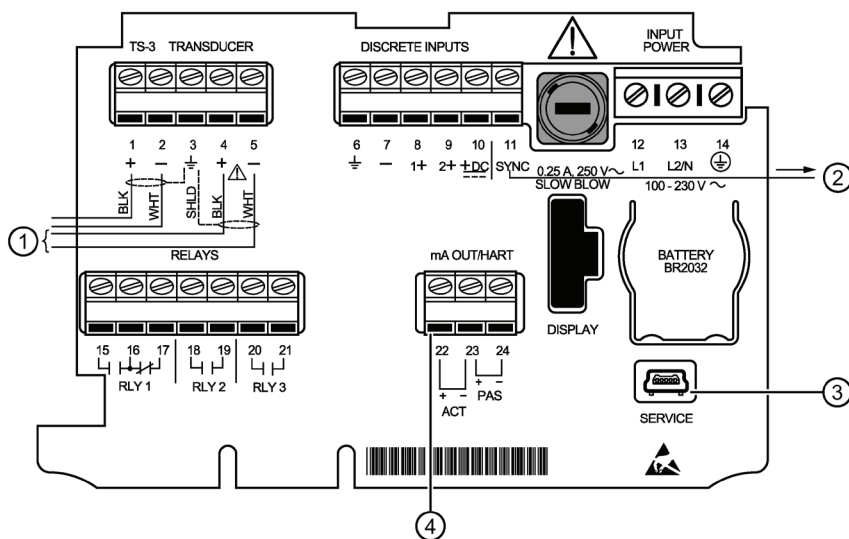

- ① To Transducer
- ② To other SIEMENS unit
- ③ USB cable connection
- ④ 4 to 20 mA Hart connection

### 5.1.7.1 Connecting via USB

#### Typical USB configuration

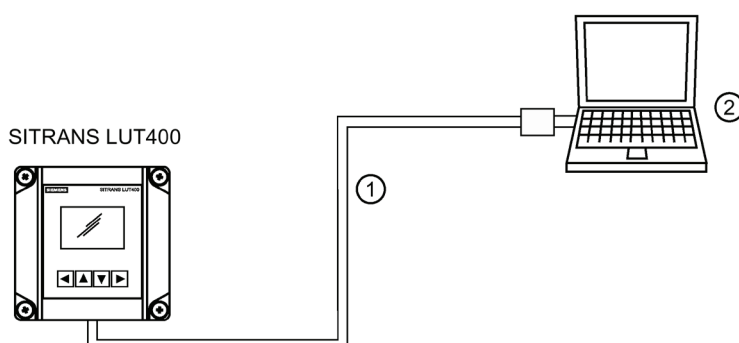

- ① USB cable
- ② Computer system

USB connection

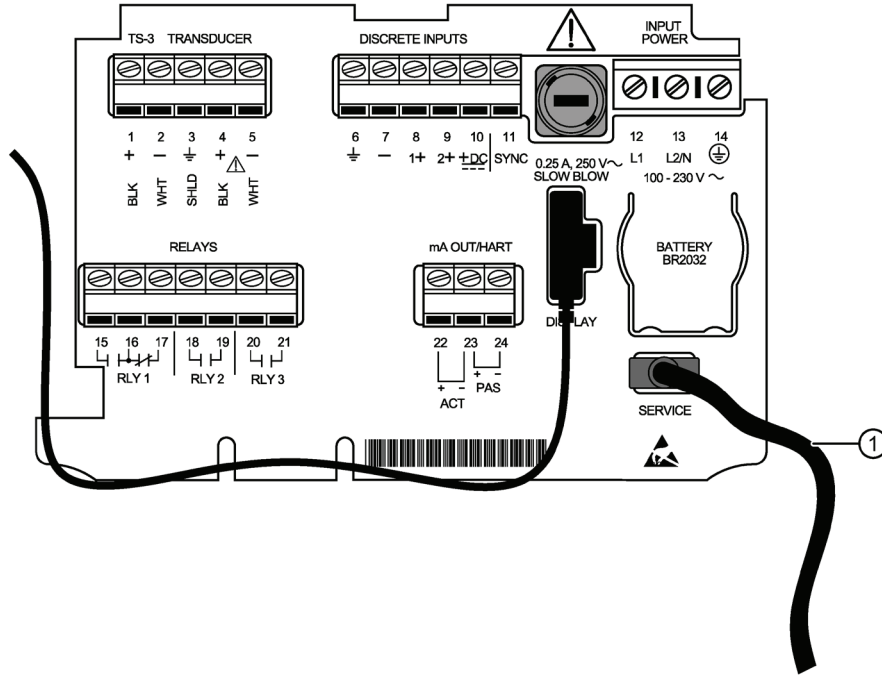

- ① USB cable  
Use 5-pin USB Mini-B cable. The cable should not exceed 3 m (9.8 ft.).

**Note**

Do not use a USB extension cable with the LUT400. Data Logging may not occur, even after extension cable has been disconnected. (If a USB extension cable has been used in error, a power reset of the device is required to restart Data Logging.)

### 5.1.7.2 Connecting HART

Typical PLC/mA configuration with Passive HART connection

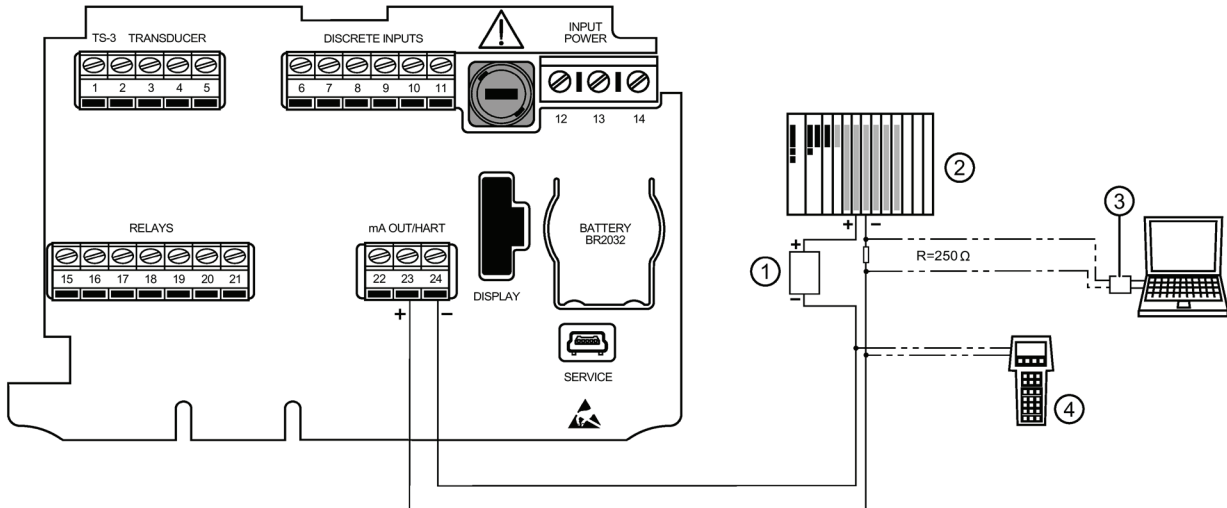

- ① DC power supply (18-30V)
- ② PLC<sup>1</sup>
- ③ HART modem
- ④ HART communicator

Typical PLC/mA configuration with Active HART connection

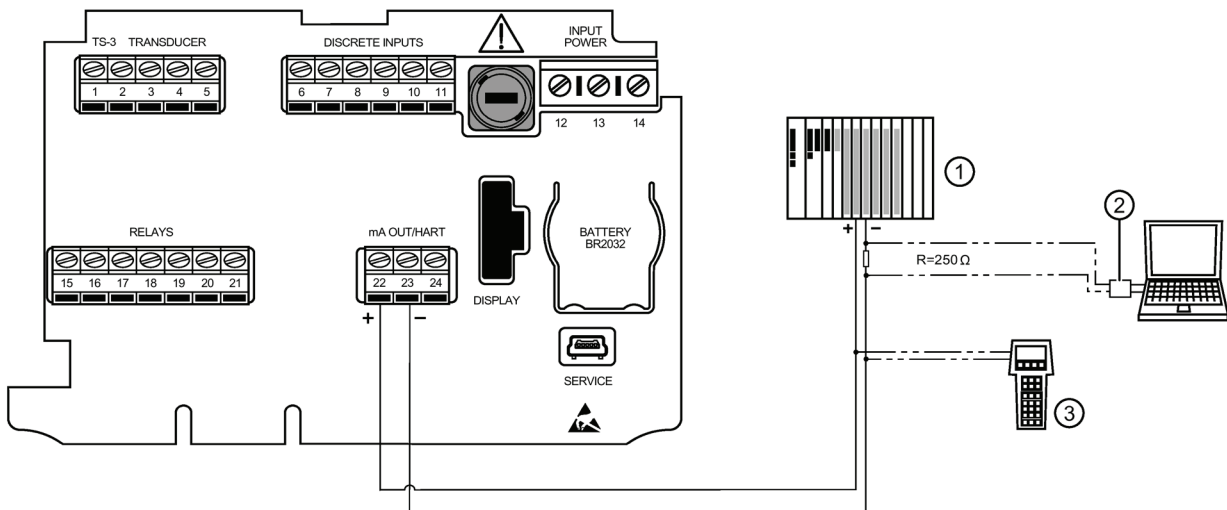

- ① PLC<sup>1</sup>
- ② HART modem
- ③ HART communicator

mA Output (HART)

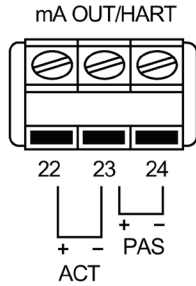

For ACTIVE HART connection (using LUT400 integral power supply), connect terminals 22 and 23.

For PASSIVE HART connection (using external power supply), connect terminals 23 and 24.

For more information, consult the mA output parameters (2.5. Current Output) in the parameter reference section.

1) Depending on the system design, the power supply may be separate from the PLC, or integral to it.

2) The nominal value for the HART resistor is 250 Ohm. For more information see application guide Working with HART, which can be downloaded from the product page of our website. Go to: [www.siemens.com/sitransLUT400](http://www.siemens.com/sitransLUT400) ([www.siemens.com/sitransLUT400](http://www.siemens.com/sitransLUT400)) under Support and click on Application Guides.

### 5.1.8 Level system synchronization

**Note**

The SITRANS LUT400 CANNOT be synchronized with the MultiRanger Plus, the original HydroRanger, or the OCMIII.

When transducer cables are run parallel with each other, synchronize the level monitors so that no device transmits while another is waiting for echo reception. If more than one ultrasonic device is being installed in the same application, the devices must be synchronized to prevent cross-talk. Optionally, the transducer cables can be run in separate grounded metal conduits.

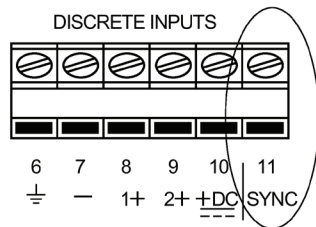

Other Siemens Transceiver

### Synchronizing with another SITRANS LUT400, or other Siemens devices

Other Siemens devices that can be synchronized with the SITRANS LUT400:

DPL+, SPL, XPL+, LU01, LU02, LU10, LUC500, DPS300, HydroRanger 200, HydroRanger Plus, EnviroRanger, MiniRanger, MultiRanger 100/200

- Mount the level monitors together in one cabinet.
- Use a common power (mains) supply and ground (earth) for all devices.
- Interconnect the SYNC terminals of all level monitors.
- Up to 16 Siemens devices can be synchronized together.

For more information or assistance, contact Siemens or your local distributor. Go to: [www.siemens.com/processautomation](http://www.siemens.com/processautomation) ([www.siemens.com/processautomation](http://www.siemens.com/processautomation)).

## 5.1.9 Discrete inputs

The SITRANS LUT400 has a 24V power bias (terminal 10) for use with the discrete inputs, or the discrete inputs can be wired using external power.

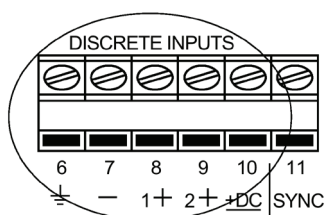

- ① Common Neg. for DIs
- ② Pos. Input for DI1
- ③ Pos. Input for DI2
- ④ Bias supply for Pos. DIs  
(ground to terminal 6)

### Discrete Inputs used with internal bias supply

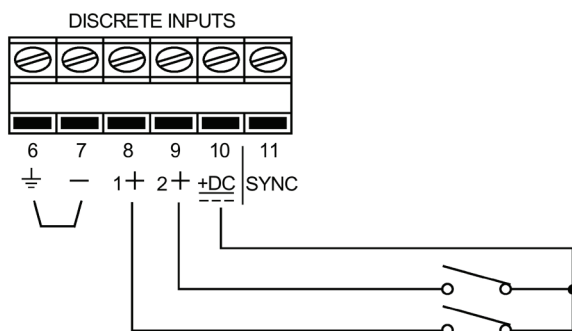

#### Note

Terminals 6 and 7 must be connected together.

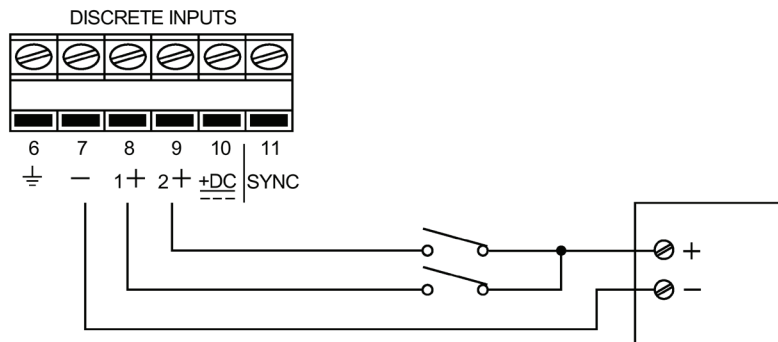
**Discrete Inputs used with external bias voltage****5.1.10 Remote mounted lid with extension cable**

The optional display lid can be mounted remotely up to 5 m from the device. The optional extension cable can be used for such an installation.

1. Remove display lid from the enclosure.
2. Carefully disconnect the existing display cable from the terminal board.

3. Separate from the device, knock out cable entry tab on blank lid:
  - a. With gasket in place, use snips to cut into lid on both sides of the cable entry knockout. Use cutting guideline to cut from bottom of lid, up to bottom of groove (as shown below).
  - b. Once both sides of knockout have been cut through all layers of the lid (including the gasket), pry upward with pliers on knockout to snap off plastic and uncover cable entry hole.

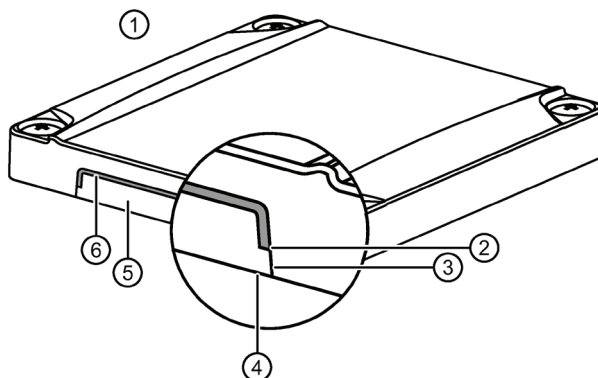

- ① Blank lid
- ② Bottom of groove
- ③ Cutting guideline
- ④ Bottom of lid
- ⑤ Cable entry knockout
- ⑥ Groove

- c. Use sand paper if necessary to smooth any sharp edges.
- d. Replace the blank lid on the enclosure.

**! WARNING**

**Ingress protection**

Ingress protection of the enclosure is reduced to IP20, and Type 4X / NEMA 4X rating is void when cable entry knock-out in the blank lid is removed.

**Note**

**Installation location**

An enclosure reduced to an IP20 rating and intended for use in nonhazardous locations must be installed in an indoor location free of dust and moisture, or be installed in a suitably rated field enclosure IP54 or better.

4. Connect the extension cable to the display connector on the terminal board. (If desired, attach second extension cable to the other end of the first extension cable.)
5. Feed the free end of the extension cable through cable entry hole on blank lid.

5.1 Connecting SITRANS LUT400

- 6. Connect extension cable to display cable on remote lid.
- 7. Secure blank lid on device and mount display lid remotely. See Remote mounted lid (Page 24).

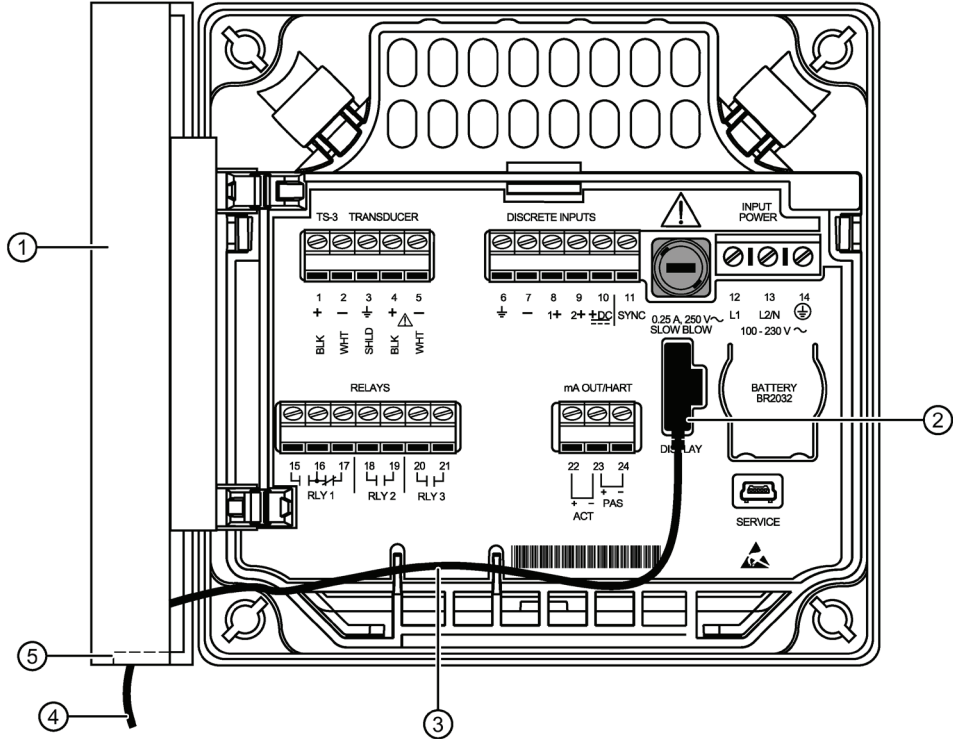

- ① Blank lid
- ② Display cable connector
- ③ Extension cable
- ④ Extension cable (2.5 or 5 m in length), to be connected to remote display lid
- ⑤ Cable entry knockout

5.1.11 Extension cable

Optional extension cables (2.5 m cables) are available to be used with remote mounted lid. Two cables can be connected together for an extension of up to 5 meters.

**Note**

It is recommended that the exposed extension cable be secured along a wall, or run through conduit to prevent damage to device, should cable be accidentally subjected to stress.



## 5.2 Connecting in hazardous area installations













### Wiring setups for hazardous area installations

The following wiring options are available for hazardous area installations:

- Non-incendive wiring (Canada)

In all cases, check the device label on your instrument, and confirm the approval rating.

#### 1. Non-incendive wiring (Canada)

<p align="center"><b>SIEMENS</b></p> <p>SITRANS LUT420 7MLxxxx-xxxx-xxxx Serial No.: GYZ / B1034567 Power Rating: 100 – 230V ~ ± 15% 50/60 Hz, 36 VA (10 W) Contact Rating: 1A/5A @ 250V ~, Non-Inductive Operating Temperature: – 20°C to 50°C Enclosure: IP65 / TYPE 4X / NEMA 4X</p> <p> Class I, Div.2, Gr. A, B, C &amp; D T3C Class II, Div. 2, Gr. F &amp; G Class III 199134 Per Drawing A5E03936871 </p> <p align="center">Siemens Milltronics Process Instruments, Peterborough Assembled in Canada with domestic and imported parts</p>	<p align="center"><b>SIEMENS</b></p> <p>SITRANS LUT430 7MLxxxx-xxxx-xxxx Serial No.: GYZ / B1034567 Power Rating: 100 – 230V ~ ± 15% 50/60 Hz, 36 VA (10 W) Contact Rating: 1A/5A @ 250V ~, Non-Inductive Operating Temperature: – 20°C to 50°C Enclosure: IP65 / TYPE 4X / NEMA 4X</p> <p> Class I, Div.2, Gr. A, B, C &amp; D T3C Class II, Div. 2, Gr. F &amp; G Class III 199134 Per Drawing A5E03936871 </p> <p align="center">Siemens Milltronics Process Instruments, Peterborough Assembled in Canada with domestic and imported parts</p>	<p align="center"><b>SIEMENS</b></p> <p>SITRANS LUT440 7MLxxxx-xxxx-xxxx Serial No.: GYZ / B1034567 Power Rating: 100 – 230V ~ ± 15% 50/60 Hz, 36 VA (10 W) Contact Rating: 1A/5A @ 250V ~, Non-Inductive Operating Temperature: – 20°C to 50°C Enclosure: IP65 / TYPE 4X / NEMA 4X</p> <p> Class I, Div.2, Gr. A, B, C &amp; D T3C Class II, Div. 2, Gr. F &amp; G Class III 199134 Per Drawing A5E03936871 </p> <p align="center">Siemens Milltronics Process Instruments, Peterborough Assembled in Canada with domestic and imported parts</p>
<p align="center"><b>SIEMENS</b></p> <p>SITRANS LUT420 7MLxxxx-xxxx-xxxx Serial No.: GYZ / B1034567 Power Rating: 10 – 32V ~, 10W Contact Rating: 1A/5A @ 250V ~, Non-Inductive Operating Temperature: – 20°C to 50°C Enclosure: IP65 / TYPE 4X / NEMA 4X</p> <p> Class I, Div.2, Gr. A, B, C &amp; D T3C Class II, Div. 2, Gr. F &amp; G Class III 199134 Per DWG. A5E03936871 </p> <p align="center">Siemens Milltronics process instruments, Peterborough Assembled in Canada with domestic and imported parts</p>	<p align="center"><b>SIEMENS</b></p> <p>SITRANS LUT430 7MLxxxx-xxxx-xxxx Serial No.: GYZ / B1034567 Power Rating: 10 – 32V ~, 10W Contact Rating: 1A/5A @ 250V ~, Non-Inductive Operating Temperature: – 20°C to 50°C Enclosure: IP65 / TYPE 4X / NEMA 4X</p> <p> Class I, Div.2, Gr. A, B, C &amp; D T3C Class II, Div. 2, Gr. F &amp; G Class III 199134 Per DWG. A5E03936871 </p> <p align="center">Siemens Milltronics process instruments, Peterborough Assembled in Canada with domestic and imported parts</p>	<p align="center"><b>SIEMENS</b></p> <p>SITRANS LUT430 7MLxxxx-xxxx-xxxx Serial No.: GYZ / B1034567 Power Rating: 10 – 32V ~, 10W Contact Rating: 1A/5A @ 250V ~, Non-Inductive Operating Temperature: – 20°C to 50°C Enclosure: IP65 / TYPE 4X / NEMA 4X</p> <p> Class I, Div.2, Gr. A, B, C &amp; D T3C Class II, Div. 2, Gr. F &amp; G Class III 199134 Per DWG. A5E03936871 </p> <p align="center">Siemens Milltronics process instruments, Peterborough Assembled in Canada with domestic and imported parts</p>

CSA Class I, Div 2 connection drawing number A5E03936871 can be downloaded from the product page of our website at [www.siemens.com/sitransLUT400](http://www.siemens.com/sitransLUT400) ([www.siemens.com/sitransLUT400](http://www.siemens.com/sitransLUT400)).

# Commissioning

## 6.1 Local Commissioning

### Local Commissioning

SITRANS LUT400 is an easy to use, and quick to commission device, with its numerous wizards, and menu driven parameters. The parameters can be modified locally using the LCD and the local push buttons, also known as the Local User Interface (LUI).

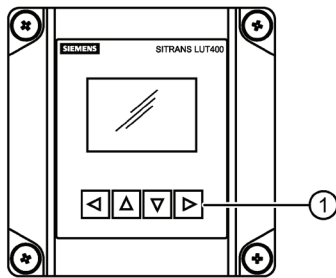

① Local push buttons

A Quick Start Wizard provides an easy step-by-step procedure to help you configure the device for a simple application. We recommend that you configure your application in the following order:

- First, run the appropriate Quick Start Wizard for your application (Level, Volume, Flow).
- Next, set up pumps via the Pump Control Wizard (if applicable).
- Lastly, configure alarms, or other controls, totalizers and samplers, referencing the respective parameters [see Parameter reference (LUI) (Page 171)]. It is important that alarms, and other controls are configured last to avoid pump relay assignments being overridden by the Quick Start Wizard.

There are two ways to access the Quick Start wizards:

- Locally (see Quick Start Wizards via LUI (Page 59))
- From a remote location (see Other Quick Start Wizards (QSW) (Page 58)).

See Level Application Example (Page 79), or Flow application example (Page 80) example for illustrations, and for the complete range of parameters, see Parameter reference (LUI) (Page 171).

## 6.2 Activating SITRANS LUT400

---

### Note

- Program Mode and Measurement mode refer to the display only. While the device is in Program mode, the output remains active and continues to respond to changes in the device.
  - To enter Program mode using the device local push buttons, press ► . Press ◀ to return to Measurement mode.
  - The display will return to Measurement mode after ten minutes of inactivity (from last button press), when in Program Mode and from within a Wizard. Pressing ► will then take you to the main navigation menu. (It will not return to the screen from which the timeout occurred.).
- 

1. Power up the device. SITRANS LUT400 automatically starts up in Measurement mode. A transition screen showing first the Siemens logo and then the current firmware revision of the LUI is displayed while the first measurement is being processed.
2. The first time the device is configured, you will be prompted to select a language (English, German, French, Spanish, Chinese, Italian, Portuguese, or Russian). To change the language again (after initial setup), see Language (6.) (Page 266).
3. Device time is set to Eastern Standard Time (EST) at the factory. To modify, see Date and Time (Page 232). The correct date and time should be set prior to configuring the device.

## 6.2.1 The LCD Display

### 6.2.1.1 Measurement mode display: Normal operation

#### Level

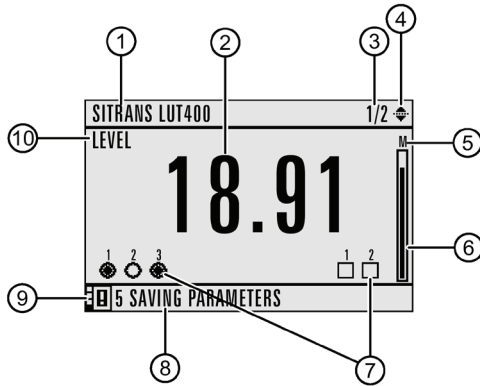

- ① Tag
- ② Measured value (level, space, distance, volume, flow, or head)
- ③ Value being displayed [Primary Variable (PV)=1 of 2, Secondary Variable (SV)=2 of 2]
- ④ Toggle indicator1 for PV or SV
- ⑤ Units
- ⑥ Bar graph indicates level
- ⑦ Secondary region indicates configured relays (left) and discrete inputs (right)
- ⑧ Text area displays status messages
- ⑨ Device status indicator
- ⑩ Selected (primary) sensor mode: level, space, distance, volume, head, or flow

#### Flow

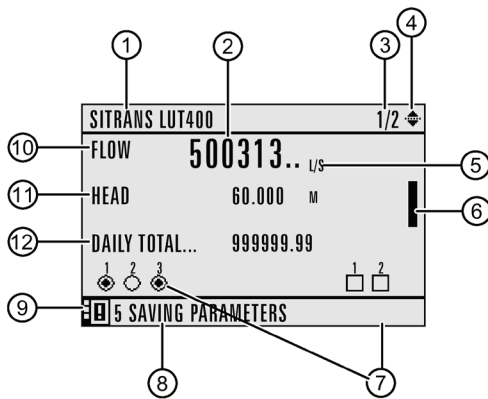

- ①-⑩ Refer to previous image.
- ⑪ Secondary sensor mode = head when primary sensor mode = flow
- ⑫ Totalizer values: display alternates between daily totalizer and running totalizer

**Fault present**



- ⑧ Text area displays a fault code and an error message
- ⑨ Service required icon appears

**6.2.1.2 PROGRAM mode display**

- A visible menu bar indicates the menu list is too long to display all items.
- The depth of the item band on the menu bar indicates the length of the menu list: a deeper band indicates fewer items.
- The position of the item band indicates the approximate position of the current item in the list. A band filled halfway down the menu bar indicates the current item is halfway down the list.

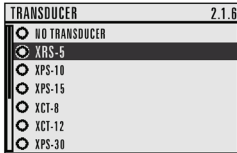

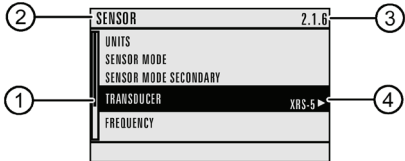

- ① Menu bar
- ② Item band
- ③ Current menu/ parameter name
- ④ Parameter number
- ⑤ Current item

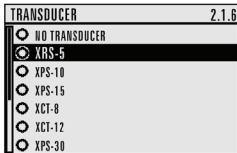

- ① Parameter name
- ② Menu in which parameter is located
- ③ Parameter number
- ④ Parameter value/selection





### 6.2.1.3 Key functions in Measurement mode

Key	Function	Result
	RIGHT arrow opens PROGRAM mode.	Opens the top level menu.
 	UP or DOWN arrow toggles between PV and SV.	LCD displays primary or secondary value.

## 6.2.2 Programming SITRANS LUT400

### Note

- To enter Program mode using the device local push buttons, press . Press  to return to Measurement mode.
- While the device is in Program mode, the output remains active and continues to respond to changes in the device.

Change parameter settings and set operating conditions to suit your specific application. (For remote operation, see Operation via SIMATIC PDM 6 (HART) (Page 164) or Operation via AMS Device Manager (HART) (Page 167).)

### Parameter menus

### Note

For the complete list of parameters with instructions, see Parameter reference (LUI) (Page 171).

Parameters are identified by name and organized into function groups, then arranged in a 5-level menu structure, as in the example below. (For full menu see LCD menu structure (Page 313).)

1. WIZARDS
2. SETUP
  - 2.1 SENSOR
  - .....
  - 2.7 PUMPS
    - 2.7.1 BASIC SETUP
    - 2.7.2 MODIFIERS
      - 2.7.2.1.1 ENABLE



## PROGRAM

### Enter PROGRAM mode

Using local push buttons:





- RIGHT arrow ► activates PROGRAM mode and opens menu level 1.

Navigating: key functions in Navigation view

---

#### Note

- In Navigation view, ARROW keys move to the next menu item in the direction of the arrow.
  - Press and hold any arrow key to scroll through a list of options or menus (in the direction of the arrow).
-

Key	Name	Menu Level	Function
 	UP or DOWN arrow	Menu or Parameter	Scroll to previous or next menu or parameter.
	RIGHT arrow	Menu Parameter	Go to first parameter in the selected menu, or open next menu. Open <b>Edit Mode</b> .
	LEFT arrow	Menu or Parameter	Open parent menu.

### Editing in PROGRAM mode

#### Selecting a listed option

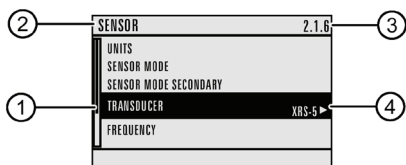

- ① Parameter name
- ② Menu name
- ③ Parameter number
- ④ Current value

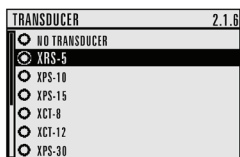

1. Navigate to the desired parameter.
2. Press RIGHT arrow ► to open Edit mode. The current selection is highlighted.
3. Scroll to a new selection.
4. Press RIGHT arrow ► to accept it. The LCD returns to parameter view and displays the new selection.



### Changing a numeric value

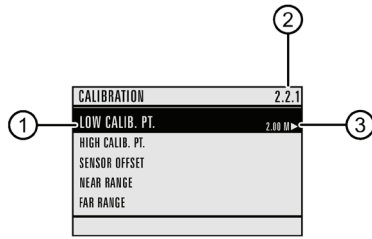



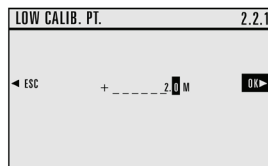

- ① Parameter name
- ② Parameter number
- ③ Current value



1. Navigate to the desired parameter.
2. When selected, the current value is displayed.
3. Press **RIGHT arrow** ► to open **Edit** mode. The cursor position is highlighted.
4. Use **LEFT** ◀ and **RIGHT arrow** ► to move cursor to digit position you wish to change.
5. As each digit is highlighted (selected), use the **▲ UP** and **Down arrow ▼** to increase or decrease the digit respectively.
6. While decimal point is selected, use **UP ▲** and **Down arrow ▼** to shift decimal position.
7. To escape without saving your changes, press **LEFT arrow** ◀ continually until **ESC** is highlighted. Press **LEFT arrow** ◀ again to escape without saving changes.  
Otherwise, when new parameter value is correct, press **RIGHT arrow** ► continually until **OK** is highlighted.
8. Press **RIGHT arrow** ► to accept the new value. The LCD returns to parameter view and displays the new selection. Review for accuracy.

## Key functions in Edit mode

Key	Name	Function	
	UP or DOWN arrow	Selecting options	Scrolls to item.
		Alphanumeric editing	- Increments or decrements digits. - Toggles plus and minus sign.
	RIGHT arrow	Selecting options	- Accepts the data (writes the parameter). - Changes from <b>Edit</b> to <b>Navigation</b> mode.
		Numeric editing	- Moves cursor one space to the right. - or with selection highlighted, accepts the data and changes from <b>Edit</b> to <b>Navigation</b> mode.
	LEFT arrow	Selecting options	Cancels <b>Edit</b> mode without changing the parameter.
		Numeric editing	- Moves cursor to plus/minus sign if this is the first key pressed. - or moves cursor one space to the left. - or with cursor on Enter sign, cancels the entry.

## 6.3 Quick Start Wizards

A Wizard provides an easy step-by-step Quick Start (QS) procedure that configures the device for a simple application. To configure the SITRANS LUT400 for applications of level, volume (standard vessel shapes), or flow, use the Quick Start Wizards via LUI (Page 59) of this chapter.

Wizards for applications employing more complex vessel shapes are available via SIMATIC PDM. See Quick Start (Volume - Linearization) in the LUT400 Communications manual.

### Other Quick Start Wizards (QSW):

Other Quick Start Wizards using various software packages are also available:

- SIMATIC PDM (HART) (Page 164)
- AMS (HART) (Page 167)
- FC375/475 (HART) (Page 168)
- FDTs (HART) (Page 169)

Before initiating a Quick Start Wizard to configure the device, you may wish to gather the necessary parameter values. Parameter Configuration Charts that list all parameters and available options for each application type are available on our website. Go to [www.siemens.com/sitransLUT400](http://www.siemens.com/sitransLUT400) ([www.siemens.com/sitransLUT400](http://www.siemens.com/sitransLUT400)) > Support > Application Guides. You can record data and select from options on the chart that apply to your application, then with this data on hand, complete the Quick Start Wizards via LUI (Page 59) below, or via another Quick Start Wizard, as referenced above.

### 6.3.1 Quick Start Wizards via LUI

1. Press ► to enter Program mode.

---

#### Note

Device continues to measure while in Program Mode. If you wish to disable the device while it is configured, see Transducer Enable (3.3.1.) (Page 250).

---

2. Choose Wizards (1.) (Page 172), Quick Start (Page 59), and then the appropriate quick start: QS Volume (Page 63), QS Flow (Page 68), or Pump Control (Page 75). [The QS Flow wizard will display on LUI for LUT430 (Pump and Flow), and LUT440 (OCM) configured models only.]
3. Follow the steps then choose **Finish** to save Quick Start parameter changes and return to Program menu, then press ◀ three times to return to Measurement mode.

---

#### Note

- The Quick Start Wizard settings are inter-related and changes apply only after you choose Finish in the final step.
  - Perform customization for your application only after the Quick Start has been completed.
- 

#### 6.3.1.1 Quick Start

##### 1.1.1. QS Level

Use this wizard to configure simple level applications.

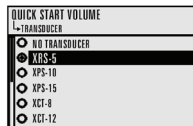
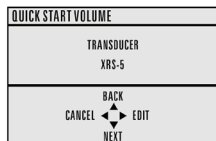

1. Press RIGHT arrow ► to activate PROGRAM mode and open menu level 1: MAIN MENU.
2. Press RIGHT arrow ► two times to navigate to menu item 1.1.1.
3. Press RIGHT arrow ► to open QS Level.
4. At each step, press DOWN arrow ▼ to accept default values and move directly to the next item, or RIGHT arrow ► to open Edit mode: the current selection is highlighted.

5. Scroll to desired item and press RIGHT arrow ► to store the change, then press DOWN arrow ▼ to continue.
6. At any time, you can press UP arrow ▲ to go back, or LEFT arrow ◀ to cancel the wizard.

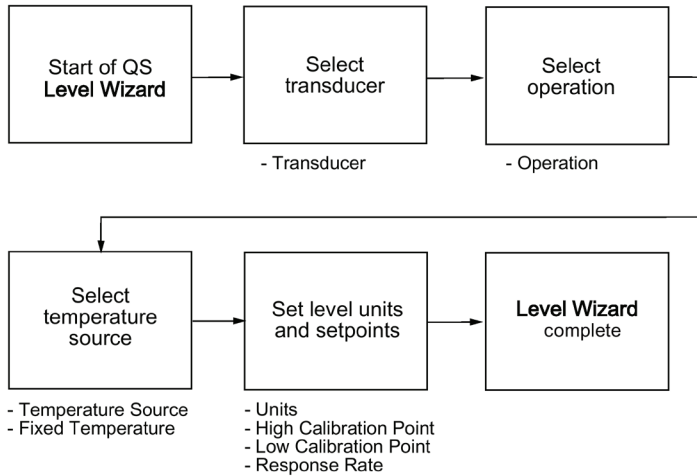

**Start of QS Level Wizard**

**Note**

The introduction screen is displayed only on the device when using the local push buttons. This screen is not part of the Quick Start when using SIMATIC PDM.

Shows the type of Wizard to be executed.

<b>Options</b>	CANCEL, START
----------------	---------------

**Transducer**

Specifies the Siemens transducer connected to the device.

<b>Options</b>	NO TRANSDUCER, XRS-5, XPS-10, XPS-15, XCT-8, XCT-12, XPS-30, XPS-40, XLT-30, XLT-60, STH
	Default: NO TRANSDUCER

**Operation**

Sets the type of measurement (and the corresponding mA output) required for the application.

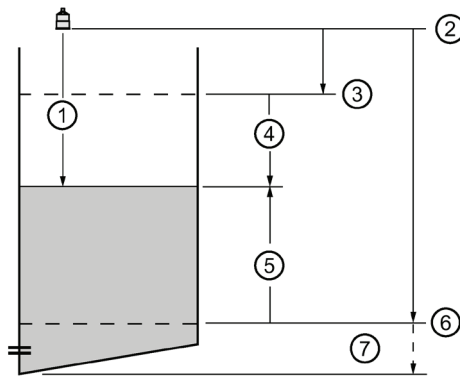

- ① Distance
- ② Sensor reference point
- ③ High calibration point
- ④ Space
- ⑤ Level
- ⑥ Low calibration point
- ⑦ Far range

Mode		Description	Reference point
LEVEL	*	Height of material	Low Calibration Point (process empty level)
SPACE		Distance to material surface	High Calibration Point (process full level)
DISTANCE			
OTHER		Do NOT select. If Operation value displays as OTHER, the device is configured as a level controller, but has been set previously to a mode other than LEVEL, SPACE, or DISTANCE. The operation mode must be set to LEVEL, SPACE, or DISTANCE to proceed with the QS Level Wizard.	

### Temperature Source

Source of the temperature reading used to adjust the speed of sound.

Options	TRANSDUCER, FIXED TEMPERATURE, EXTERNAL TS-3, AVERAGE OF SENSORS
	Default: TRANSDUCER

See Temperature Source (2.12.1.3.) (Page 222) Temperature Source for more details.

### Fixed Temperature

Use this feature if a temperature sensing device is not used.

Value	Range: -100.0 to +150.0 °C
	Default: +20.0 °C

This parameter is only displayed if FIXED TEMPERATURE selected for Temperature Source.

**Units**

Sensor measurement units.

<b>Options</b>	m, cm, mm, ft, in
	Default: m

**Note**

For the purpose of this example, all values are assumed to be in meters (m).

---

**High Calibration Point**

Distance from Sensor Reference Point to High Calibration Point: usually process full level.

<b>Value</b>	Range: 0.000 to 60.000
	Default: 0.000

**Low Calibration Point**

Distance from Sensor Reference Point to Low Calibration Point: usually process empty level.

<b>Value</b>	Range: 0.000 to 60.000
	Default: 60.000

**Response Rate**

Sets the reaction speed of the device to measurement changes in the target range.

---

**Note**

- Response Rate can only be set through the Quick Start Wizard, and any changes made to Fill Rate per Minute (2.3.1.) (Page 178), Empty Rate per Minute (2.3.2.) (Page 178), or Damping Filter (2.3.3.) (Page 178) parameters following the completion of the wizard will supersede the Response Rate setting.
  - Response Rate always displays in m/minute.
- 

<b>Options</b>	SLOW (0.1 m/min)
	MEDIUM (1.0 m/min)
	FAST (10 m/min)
	Default: SLOW (0.1 m/min)

Use a setting just faster than the maximum filling or emptying rate (whichever is greater). Slower settings provide higher accuracy, faster settings allow for more rapid level fluctuations.

### End of QS Level Wizard

For QS to be successful, all changes must be applied.

<b>Options</b>	BACK, CANCEL, FINISH (Display returns to 1.1 Quick Start menu when Quick Start is successfully completed or cancelled. If CANCEL is selected, no changes are written to the device.)
----------------	---

To transfer Quick Start values to the device and return to Program menu, press DOWN arrow ▼ (Finish). Then press LEFT arrow ◀ three times to return to Measurement mode.

### 6.3.1.2 QS Volume

Use this wizard to configure volume applications employing standard vessel shapes.

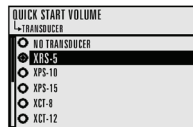
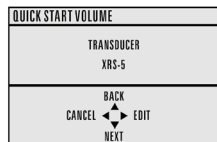

1. Press RIGHT arrow ► to activate PROGRAM mode and open menu level 1: MAIN MENU.
2. Press RIGHT arrow ► two times to navigate to menu item 1.1.1.
3. Press RIGHT arrow ► to open QS Volume.
4. At each step, press DOWN arrow ▼ to accept default values and move directly to the next item, or RIGHT arrow ► to open Edit mode: the current selection is highlighted.
5. Scroll to desired item and press RIGHT arrow ► to store the change, then press DOWN arrow ▼ to continue.
6. At any time, you can press UP arrow ▲ to go back, or LEFT arrow ◀ to cancel the wizard.

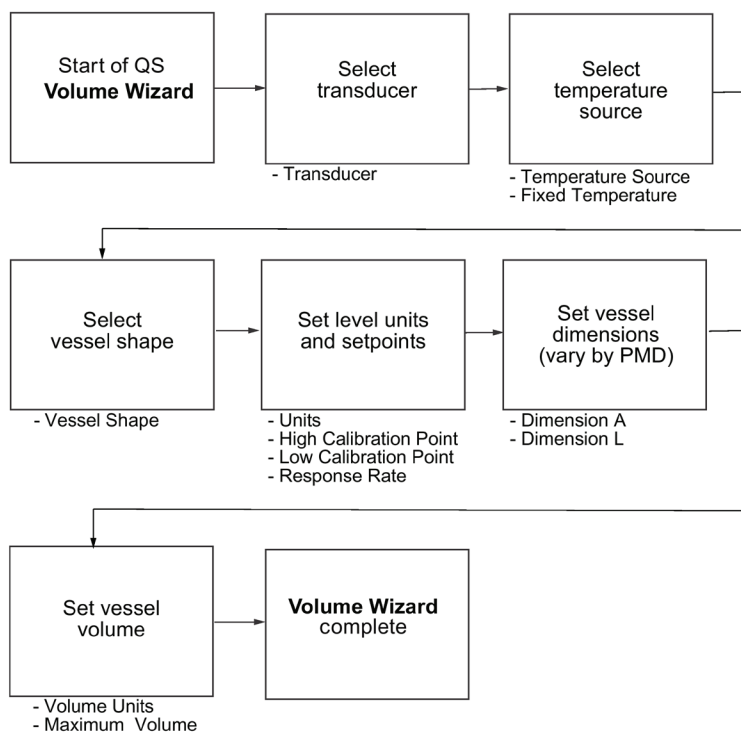

### Start of QS Volume Wizard

#### Note

The introduction screen is displayed only on the device when using the local push buttons. This screen is not part of the Quick Start when using SIMATIC PDM.

Shows the type of Wizard to be executed.

Options	CANCEL, START
---------	---------------

#### Transducer

Specifies the Siemens transducer connected to the device.

Options	NO TRANSDUCER, XRS-5, XPS-10, XPS-15, XCT-8, XCT-12, XPS-30, XPS-40, XLT-30, XLT-60, STH
	Default: NO TRANSDUCER



### Temperature Source

Source of the temperature reading used to adjust the speed of sound.

<b>Options</b>	TRANSDUCER, FIXED TEMPERATURE, EXTERNAL TS-3, AVERAGE OF SENSORS
	Default: TRANSDUCER

See Temperature Source (2.12.1.3.) (Page 222) Temperature Source for more details.

### Fixed Temperature

Use this feature if a temperature sensing device is not used.

<b>Value</b>	Range: -100.0 to +150.0 °C
	Default: +20.0 °C

This parameter is only displayed if FIXED TEMPERATURE selected for Temperature Source.

### Vessel Shape

Defines the vessel shape and allows the SITRANS LUT400 to calculate volume instead of level. If NONE is selected, no volume conversion is performed. Select the vessel shape matching the monitored vessel or reservoir.

<b>Options</b>	NONE, LINEAR, CYLINDER, PARABOLIC BOTTOM, HALF SPHERE BOTTOM, FLAT SLOPED BOTTOM, PARABOLIC ENDS, SPHERE, CONICAL BOTTOM, CURVE TABLE, LINEAR TABLE
	Default: LINEAR

See Vessel Shape (2.6.1.) (Page 184) for illustration. If CURVE TABLE or LINEAR TABLE selected, enter values for level and volume breakpoints after completing the wizard (see Table 1-8 (2.6.7.) (Page 187)).

### Units

Sensor measurement units.

<b>Options</b>	m, cm, mm, ft, in
	Default: m

---

### Note

For the purpose of this example, all values are assumed to be in meters (m).

---

**High Calibration Point**

Distance from Sensor Reference Point to High Calibration Point: usually process full level.

<b>Value</b>	Range: 0.000 to 60.000
	Default: 0.000

**Low Calibration Point**

Distance from Sensor Reference Point to Low Calibration Point: usually process empty level.

<b>Value</b>	Range: 0.000 to 60.000
	Default: 60.000

**Response Rate**

Sets the reaction speed of the device to measurement changes in the target range.

**Note**

- Response Rate can only be set through the Quick Start Wizard, and any changes made to Fill Rate per Minute (2.3.1.) (Page 178), Empty Rate per Minute (2.3.2.) (Page 178), or Damping Filter (2.3.3.) (Page 178) parameters following the completion of the wizard will supersede the Response Rate setting.
- Response Rate always displays in m/minute.

<b>Options</b>	SLOW (0.1 m/min)
	MEDIUM (1.0 m/min)
	FAST (10 m/min)
	Default: SLOW (0.1 m/min)

Use a setting just faster than the maximum filling or emptying rate (whichever is greater). Slower settings provide higher accuracy, faster settings allow for more rapid level fluctuations.

**Dimension A**

The height of the vessel bottom when the bottom is conical, pyramidal, parabolic, spherical, or flat -sloped.

<b>Value</b>	Range: 0.000 to 99.999
	Default: 0.000

**Dimension L**

Length of the cylindrical section of a horizontal parabolic end vessel.

<b>Value</b>	Range: 0.000 to 99.999
	Default: 0.000

**Volume Units**

Determines volume measurement units.

<b>Value</b>	L, USGAL, IMPGAL, CUM, USER DEFINED *
	Default: L

\* If USER DEFINED option selected, the value must be set after completing the wizard. See User Defined Unit (2.6.6.) (Page 187).

**Maximum Volume**

The maximum volume of the vessel. Enter the vessel volume corresponding to the High Calibration Point. For example, if your maximum vessel volume is 8000 L, enter a value of 8000.

<b>Value</b>	Range: 0.0 to 9999999
	Default: 100.0

**End of QS Volume Wizard**

For QS to be successful, all changes must be applied.

<b>Options</b>	BACK, CANCEL, FINISH (Display returns to 1.1 Quick Start menu when Quick Start is successfully completed or cancelled. If CANCEL is selected, no changes are written to the device.)
----------------	---

To transfer Quick Start values to the device and return to Program menu, press DOWN arrow ▼ (Finish). Then press LEFT arrow ◀ three times to return to Measurement mode.

### 6.3.1.3 QS Flow

Use this wizard to configure simple flow applications.

(Visible on LUT430 (Pump and Flow), and LUT440 (OCM) configured models only.)

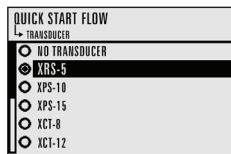
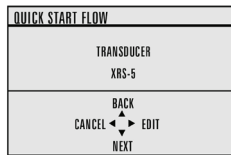

1. Press RIGHT arrow ► to activate PROGRAM mode and open menu level 1: MAIN MENU.
2. Press RIGHT arrow ► two times to navigate to menu item 1.1.1.
3. Press RIGHT arrow ► to open QS Flow.
4. At each step, press DOWN arrow ▼ to accept default values and move directly to the next item, or RIGHT arrow ► to open Edit mode: the current selection is highlighted.
5. Scroll to desired item and press RIGHT arrow ► to store the change, then press DOWN arrow ▼ to continue.
6. At any time, you can press UP arrow ▲ to go back, or LEFT arrow ◀ to cancel the wizard.

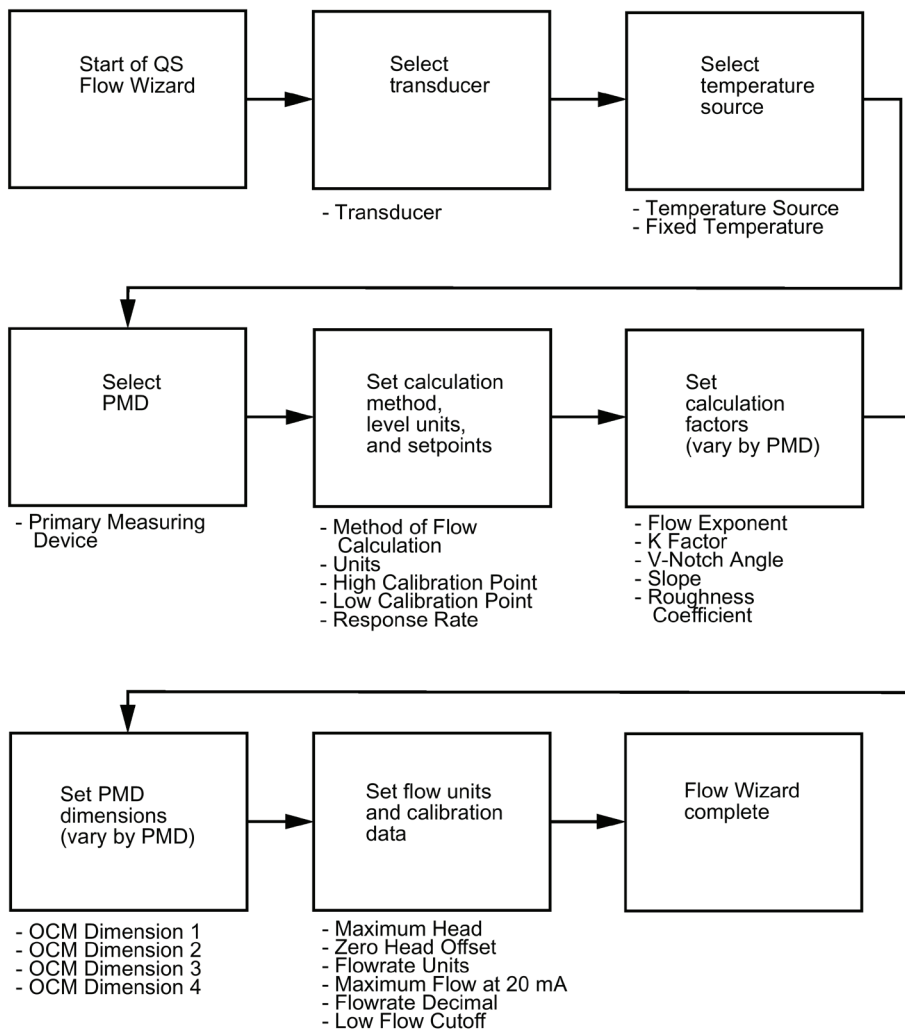

### Start of QS Flow Wizard

#### Note

The introduction screen is displayed only on the device when using the local push buttons. This screen is not part of the Quick Start when using SIMATIC PDM.

Shows the type of Wizard to be executed.

Options	CANCEL, START
---------	---------------

#### Transducer

Specifies the Siemens transducer connected to the device.

Options	NO TRANSDUCER, XRS-5, XPS-10, XPS-15, XCT-8, XCT-12, XPS-30, XPS-40, XLT-30, XLT-60, STH
	Default: NO TRANSDUCER

**Temperature Source**

Source of the temperature reading used to adjust the speed of sound.

<b>Options</b>	TRANSDUCER, FIXED TEMPERATURE, EXTERNAL TS-3, AVERAGE OF SENSORS
	Default: TRANSDUCER

See Temperature Source (2.12.1.3.) (Page 222) Temperature Source for more details.

**Fixed Temperature**

Use this feature if a temperature sensing device is not used.

<b>Value</b>	Range: -100.0 to +150.0 °C
	Default: +20.0 °C

This parameter is only displayed if FIXED TEMPERATURE selected for Temperature Source.

**Primary Measuring Device**

Defines the primary measuring device (PMD) to be used in the application.

<b>Options</b>	EXPONENTIAL DEVICES, RECTANGULAR FLUME BS-3680, ROUND NOSE HORIZONTAL CR. BS-3680, TRAPEZOIDAL FLUME BS-3680, U-FLUME BS- 3680, FINITE CREST WEIR BS-3680, THIN PLATE RECT. WEIR BS-3680, THIN PLATE V-NOTCH WEIR BS-3680, RECT. WEIR CONTRACTED, ROUND PIPE, PALMER BOWLUS FLUME, H-FLUME, OTHER*
	Default: EXPONENTIAL DEVICES

\* Option will be set to OTHER if the wizard was run previously via HART software tool (such as SIMATIC PDM), and the device was set to OFF or UNIVERSAL HEAD VS. FLOW. If this is initial configuration, the PMD can only be set for no calculation (OFF), or for linearization (UNIVERSAL HEAD VS. FLOW) via HART software tools (SIMATIC PDM, AMS, FC375/475).

**Method of Flow Calculation**

Sets the method of flow calculation.

<b>Options</b>	ABSOLUTE, RATIOMETRIC
	Default: ABSOLUTE

**Units**

Sensor measurement units.

<b>Options</b>	m, cm, mm, ft, in
	Default: m

**Note**

For the purpose of this example, all values are assumed to be in meters (m).

### High Calibration Point

Distance from Sensor Reference Point to High Calibration Point: usually process full level.

<b>Value</b>	Range: 0.000 to 60.000
	Default: 0.000

### Low Calibration Point

Distance from Sensor Reference Point to Low Calibration Point: usually process empty level.

<b>Value</b>	Range: 0.000 to 60.000
	Default: 60.000

### Response Rate

Sets the reaction speed of the device to measurement changes in the target range.

#### Note

- Response Rate can only be set through the Quick Start Wizard, and any changes made to Fill Rate per Minute (2.3.1.) (Page 178), Empty Rate per Minute (2.3.2.) (Page 178), or Damping Filter (2.3.3.) (Page 178) parameters following the completion of the wizard will supersede the Response Rate setting.
- Response Rate always displays in m/minute.

<b>Options</b>	SLOW (0.1 m/min)
	MEDIUM (1.0 m/min)
	FAST (10 m/min)
	Default: SLOW (0.1 m/min)

Use a setting just faster than the maximum filling or emptying rate (whichever is greater). Slower settings provide higher accuracy, faster settings allow for more rapid level fluctuations.

### Calculation Factors

#### Note

- The following five parameters will display in the wizard based on the PMD selected above.
- These parameters are used in the flow calculation formula (see Method of Flow Calculation (Page 306)).

### Flow Exponent

(PMD = EXPONENTIAL DEVICES)

The exponent for the flow calculation formula. (See Method of Flow Calculation (Page 306))

<b>Value</b>	Range: -999.000 to 9999.000
	Default: 1.550

**K Factor**

(PMD = EXPONENTIAL DEVICES)

The constant used in the flow calculation formula for absolute calculation of an exponential device only.

<b>Value</b>	Range: -999.000 to 9999.000
	Default: 1.000

**V Notch Angle**

(PMD = THIN PLATE V-NOTCH WEIR)

The V-Notch angle used in the flow calculation formula.

<b>Value</b>	Range: 25.000 to 95.000
	Default: 25.000

**Slope**

(PMD = TRAPEZOIDAL FLUME or ROUND PIPE)

The Flow Slope used in the flow calculation formula.

<b>Value</b>	Range: -999.000 to 9999.000
	Default: 0.000

**Roughness Coefficient**

(PMD = ROUND PIPE)

The Flow Roughness Coefficient used in the flow calculation formula.

<b>Value</b>	Range: -999.000 to 9999.000
	Default: 0.000

**PMD Dimensions****Note**

- For each PMD excluding Exponential Devices, and Other, you must enter up to four dimensions.
- In the wizard, you will be prompted for each dimension required for the PMD selected, and the respective PMD dimension name will be displayed.

PMD selected	Wizard dimension name (parameter menu reference)
<b>Rectangular Flume BS-3680</b>	
	APPROACH WIDTH B
	THROAT WIDTH B
	HUMP HEIGHT P
	THROAT LENGTH L



PMD selected	Wizard dimension name (parameter menu reference)
<b>Round Nose Horizontal Crest Weir BS-3680</b>	
	CREST WIDTH B
	CREST HEIGHT P
	CREST LENGTH L
<b>Trapezoidal Flume BS-3680</b>	
	APPROACH WIDTH B
	THROAT WIDTH B
	HUMP HEIGHT P
	THROAT LENGTH L
<b>U-Flume BS-3680</b>	
	APPROACH DIAMETER DA
	THROAT DIAMETER D
	HUMP HEIGHT P
	THROAT LENGTH L
<b>Finite Crest Weir BS-3680</b>	
	CREST WIDTH B
	CREST HEIGHT P
	CREST LENGTH L
<b>Thin Plate Rectangular Weir BS-3680</b>	
	APPROACH WIDTH B
	CREST WIDTH B
	CREST HEIGHT P
<b>Rectangular Weir Contracted</b>	
	CREST WIDTH B
<b>Round Pipe</b>	
	PIPE INSIDE DIAMETER D
<b>Palmer Bowlus Flume</b>	
	MAXIMUM FLUME WIDTH HMAX
<b>H-Flume</b>	
	MAXIMUM LISTED HEAD HMAX

### Maximum Head

The maximum level value associated with the PMD.

<b>Value</b>	Range: 0.000 to 60.000
	Default: 60.000

### Zero Head Offset

The difference (positive or negative) between Low Calibration Point and zero head (level at zero flow).

<b>Value</b>	Range: -60.000 to 60.000
	Default: 0.000

**Flowrate Units**

The volume units used to display total flow.

<b>Options</b>	L/S, L/MIN, CUFT/S, CUFT/D, GAL/MIN, GAL/D, IMPGAL/MIN, IMPGAL/D, CUM/H, CUM/D, MMGAL/D, USER DEFINED *
	Default: L/S

\* If USER DEFINED option selected, the value must be set after completing the wizard. See User Defined Unit (2.15.3.8.) (Page 239).

**Maximum Flow at 20 mA**

The maximum flowrate.

<b>Value</b>	Range: -999 to 9999999
	Default: 100

**Flowrate Decimal**

The maximum number of decimal units to be displayed.

<b>Options</b>	NO DIGITS, 1 DIGIT, 2 DIGITS, 3 DIGITS
	Default: NO DIGITS

**Low Flow Cutoff**

Eliminates totalizer activity for head levels at or below the cutoff value.

<b>Value</b>	Range: 0.000 to 60.000
	Default: 0.000

**End of QS Volume Wizard**

For QS to be successful, all changes must be applied.

<b>Options</b>	BACK, CANCEL, FINISH (Display returns to 1.1 Quick Start menu when Quick Start is successfully completed or cancelled. If CANCEL is selected, no changes are written to the device.)
----------------	---

To transfer Quick Start values to the device and return to Program menu, press DOWN arrow ▼ (Finish). Then press LEFT arrow ◀ three times to return to Measurement mode.

**Note**

It is strongly recommended that an Auto Zero Head be performed after completion of the wizard to ensure best accuracy. See Auto Zero Head (2.15.2.) (Page 235).

---

### 6.3.1.4 Pump Control

Use this wizard to configure pumps if they will be used in your application. Be sure to first complete the applicable Quick Start Wizard.

1. Press RIGHT arrow ► to activate PROGRAM mode and open menu level 1: MAIN MENU.
2. Press RIGHT arrow ► two times to navigate to menu item 1.1.
3. Press RIGHT arrow ► to open QS Level.
4. At each step, press DOWN arrow ▼ to accept default values and move directly to the next item, or RIGHT arrow ► to open Edit mode: the current selection is highlighted.
5. Scroll to desired item and press RIGHT arrow ► to store the change, then press DOWN arrow ▼ to continue.
6. At any time, you can press UP arrow ▲ to go back, or LEFT arrow ◀ to cancel the wizard.

#### Start of Wizard - Pump Control

##### Note

The introduction screen is displayed only on the device when using the local push buttons. This screen is not part of the Quick Start when using SIMATIC PDM.

*Shows the type of Wizard to be executed.*

<b>Options</b>	CANCEL, START
----------------	---------------

##### Number of Pumps

*Select the number of pumps to be used with pump control.*

<b>Options</b>	NONE, 2
	Default: NONE

If set to NONE, pump control is disabled.

<b>Options</b>	NONE, 2
	Default: NONE

If set to NONE, pump control is disabled.

##### Relay Pump 1

*Selects the relay assigned to Pump 1.*

<b>Options</b>	RELAY 2, RELAY 3
	Default: RELAY 2

**Relay Pump 2 View only.**

Automatically sets the relay assigned to Pump 2 based on relay selected for Pump 1 in previous step.

<b>Options</b>	If Relay Pump 1 = RELAY 2, then Relay Pump 2 = RELAY 3
<b>(View Only)</b>	If Relay Pump 1 = RELAY 3, then Relay Pump 2 = RELAY 2

**Pump Control Mode**

Sets the control algorithm used to trip the relay.

<b>Options supported per model</b>	<b>LUT420 Level Controller:</b> ALTERNATE DUTY ASSIST, ALTERNATE DUTY BACKUP
	<b>LUT430 Pump and Flow Controller:</b> ALTERNATE DUTY ASSIST, ALTERNATE DUTY BACKUP, SERVICE RATIO DUTY ASSIST, SERVICE RATIO DUTY BACKUP, FIXED DUTY ASSIST, FIXED DUTY BACKUP
	<b>LUT440 High Accuracy OCM:</b> ALTERNATE DUTY ASSIST, ALTERNATE DUTY BACKUP, SERVICE RATIO DUTY ASSIST, SERVICE RATIO DUTY BACKUP, FIXED DUTY ASSIST, FIXED DUTY BACKUP
	Default (all models): ALTERNATE DUTY ASSIST

See Pump Control Mode (Page 189) 2.7.1.4. for descriptions of each.

**Service Ratio Pump 1**

Selects pump usage based on the RUN time ratio rather than last used.

<b>Value</b>	Range: 0 to 255
	Default: 1

This parameter displays only if a Service Ratio algorithm is selected for **Pump Control Mode**.

**Service Ratio Pump 2**

Selects pump usage based on the RUN time ratio rather than last used.

<b>Value</b>	Range: 0 to 255
	Default: 1

This parameter displays only if a Service Ratio algorithm is selected for **Pump Control Mode**.

**Run Time Relay 2**

Set the amount of time that pump Relay 2 has run, defined in hours.

<b>Value</b>	Range: 0 to 999999
	Default: 0

Use the default value for new pumps, or set this value for existing pumps with accumulated run time.

(This parameter displays only if a Service Ratio algorithm is selected for **Pump Control Mode**.)

### Run Time Relay 3

*Set the amount of time that pump Relay 3 has run, defined in hours.*

<b>Value</b>	Range: 0 to 999999
	Default: 0

Use the default value for new pumps, or set this value for existing pumps with accumulated run time.

(This parameter displays only if a Service Ratio algorithm is selected for **Pump Control Mode**.)

### ON Setpoint Pump 1

*The level at which Pump 1 turns ON, defined in Units (2.1.1.) (Page 172)*

<b>Value</b>	Range: 0.000 to 99999.000
	Default: 0.000

### ON Setpoint Pump 2

*The level at which Pump 2 turns ON, defined in Units (2.1.1.) (Page 172)*

<b>Value</b>	Range: 0.000 to 99999.000
	Default: 0.000

### OFF Setpoint Pump 1

The level at which Pump 1 turns OFF, defined in 2.1.1. Units (Page 172)

<b>Value</b>	Range: 0.000 to 99999.000
	Default: 0.000

### OFF Setpoint Pump 2

The level at which Pump 2 turns OFF, defined in Units (2.1.1.) (Page 172).

<b>Value</b>	Range: 0.000 to 99999.000
	Default: 0.000

### End of Wizard - Pump Control

*For Wizard to be successful, all changes must be applied.*

<b>Options</b>	BACK, CANCEL, FINISH (Display returns to Pump Control menu when Wizard is successfully completed or cancelled. If CANCEL is selected, no changes are written to the device.)
----------------	--

To transfer values to the device and return to Program menu, press **DOWN arrow ▼** (Finish).

Then press **LEFT arrow ◀** two times to return to Measurement mode.

### 6.4 Accuracy

To obtain optimum accuracy, follow the steps below:

1. Perform an auto sensor offset (Auto Sensor Offset (2.2.6.) (Page 177))
2. Then perform an auto sound velocity (Auto Sound Velocity (2.12.1.6.) (Page 223))

**Note**

The order is important - the auto sensor offset must be done before the auto sound velocity.

### 6.5 Requesting an Echo Profile

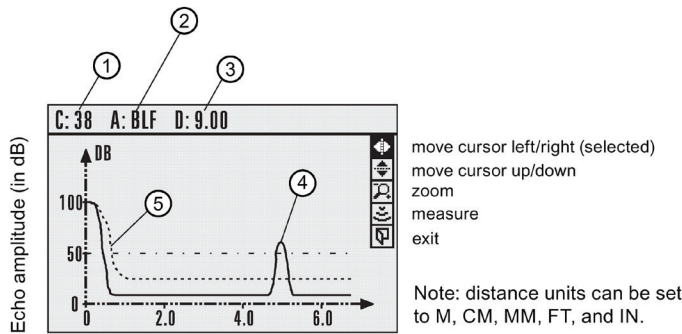

- ① Confidence<sup>1</sup>
- ② Algorithm<sup>2</sup>  
BLF (Best of First or Largest Echo)
- ③ Distance from transducer face to target
- ④ Echo
- ⑤ TVT

<sup>1</sup> See Confidence (3.2.9.2.) (Page 249)

<sup>2</sup> See Algorithm (2.12.2.1.) (Page 224)

- In PROGRAM mode, navigate to: Main Menu > Diagnostics (3.2.) > Echo Profile (3.2.1.).
- Press RIGHT arrow ► to request a profile.
- Use UP ▲ or DOWN ▼ arrow to scroll to an icon. When an icon is highlighted, that feature becomes active.
- To move a cross-hair, press RIGHT ► arrow to increase the value, LEFT ◀ arrow to decrease.
- To Zoom into an area, position the intersection of the cross-hairs at the center of that area, select Zoom, and press RIGHT arrow . Press LEFT arrow to Zoom out.
- To update the profile, select Measure and press RIGHT ► arrow .
- To return to the previous menu, select Exit then press RIGHT ► arrow .

## 6.6 Device Address

Setting a device address is not necessary for local operation, but must be set if configuring the SITRANS LUT400 for use on a HART network. See Device Address (4.1.) (Page 264).

## 6.7 Testing the configuration

After programming the device, it is recommended that you test the device to ensure that it performs to your specifications. This test can be run in simulation mode or by varying the actual level in the application. The latter is preferred as it more accurately represents running conditions. However, if it is not possible to do a physical test, a simulation will ensure that control programming is correct. For further details, see Pump relay behaviour during simulation (Page 156), and Application test (Page 159).

## 6.8 Application examples

In the examples that follow, substitute your own application details. If the examples do not apply to your application, check the applicable parameter reference for the available options.

### 6.8.1 Level Application Example

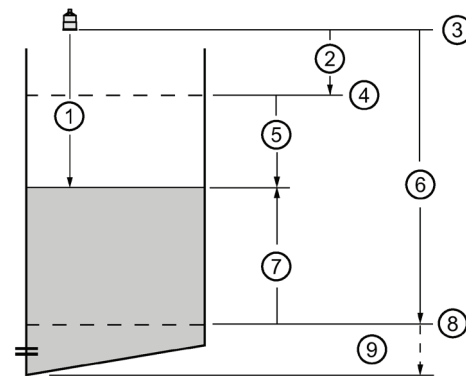

- ① Distance 8.5 m
- ② 1.0 m
- ③ Sensor reference point
- ④ High calibration point
- ⑤ Space 7.5 m
- ⑥ 15.0 m
- ⑦ Level 6.5 m
- ⑧ Low calibration point
- ⑨ Far range

Quick Start Parameter	Setting	Description
Transducer	XPS-15	Transducer to be used with the LUT400.
Operation	LEVEL	Material level referenced from Low Cal. Point.
Temperature Source	TS-3	Temperature source.
Units	M	Sensor measurement units.
High Calibration Point	1.0	Process full level.
Low Calibration Point	15.0	Process empty level.
Response Rate	SLOW	Sets Fill Rate <sup>1)</sup> / Empty Rate to 0.1 m/minute.

<sup>1)</sup> see Fill Rate per Minute (2.3.1.) (Page 178)

The application is a vessel that takes an average 3 hours (180 minutes) to fill and 3 weeks to empty.

Fill rate = (Low calibration point – High calibration point ) / fastest of fill or empty time

= (15.5 m – 1 m) / 180 min.

= 14.5 m /180 min. = 0.08 m/min.

## 6.8.2 Flow application example

### 6.8.2.1 Parshall Flume

In this example, a 12 inch (0.305 m) Parshall Flume has been installed in an open channel.

As per the supplier's data sheet, the device has been rated for a maximum flow of 1143 m<sup>3</sup>per hour at a maximum head of 0.6 m.

The Parshall Flume is considered an exponential device, therefore the supplier's data sheet includes a flow exponent value of 1.522.

The SITRANS LUT400, and the XRS-5 transducer have been installed 1.6 m above the channel beside the TS-3 external temperature sensor.

During intermittent peak flow times, the head level can be expected to rise at a rate of approximately 0.12 m/minute. The application also calls for a flow sampler to be activated every 1000 m<sup>3</sup>, or 24 hours (whichever comes first), and for a fail-safe alarm to activate in the event of a loss of echo or cable fault.



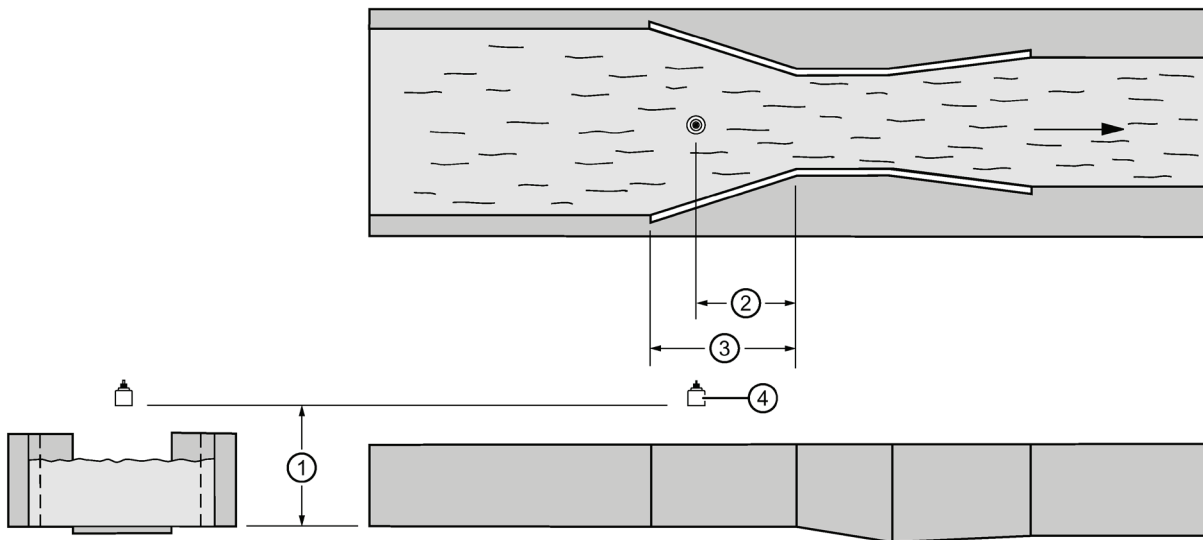

- ① Zero head
- ② 2/3 Converging dimension
- ③ Converging dimension
- ④ Transducer

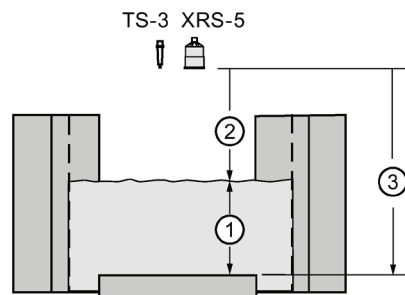

- ① Head 0.6 m
- ② High calibration 1.0 m
- ③ Low Calibration 1.6 m

### Initial Device Setup

Quick Start Parameter	Setting/ Value	Description
Transducer	XRS-5	For best accuracy, an XRS-5 transducer should be used in conjunction with the High Accuracy SITRANS LUT440.
Temperature Source	TS-3	For best accuracy, a TS-3 external temperature sensor is required.
Primary Measuring Device (PMD)	Exponential	Parshall Flumes are a type of exponential device.
Flow Exponent	1.522	Available from the PMD supplier data sheet.
Units	m	Units corresponding to the head measurement.
Low Calibration Point	1.6	The distance to the empty point or bottom of the flume. This sets the 4 mA setpoint.

Quick Start Parameter	Setting/ Value	Description
High Calibration Point	1.0	The distance to the Max. Head. This sets the 20 mA setpoint.
Response Rate	Medium(1.0 m/min)	Response rate is set to be faster than the fastest rise in material level under typical operating conditions. In this example, the rate is faster than the Peak Time rate provided by the end user.
Method of Flow Calculation	Ratiometric	Used when the Max. Head and Max. Flow values are provided.
Maximum Head	0.6 m	Available from the PMD supplier data sheet.
Flowrate Units	Cum/hr	Set per end user requirements.
Maximum Flow at 20 mA	1143	Available from the PMD supplier data sheet.
Flowrate Decimal	No Digits	For the purpose of this example, decimals are not required.
Low Flow Cutoff	0.00	This parameter stops the LUT440 from totalizing if the head value corresponding to low flow is reached. This prevents flow from being totalized when the head level reaches the ineffective point of the PMD. Refer to the PMD data sheets for ratings.

Continue with alarm setup below.

#### Fail-safe Alarm setup

Parameter	Setting/ Value	Description
Enable (Enable (2.8.8.1.) (Page 207))	Enabled	By selecting Enabled, the fail-safe alarm is now activated.
Assigned Relay (Assigned Relay (2.8.8.2.) (Page 208))	Relay 1	Select relay to be used for fail-safe alarm. Relay 1 is the dedicated alarm relay for the LUT400.

Continue with sampler setup.

#### Sampler Setup

Parameter	Setting/ Value	Description
Enable (2.11.4.1.) (Page 220)	Enabled	By selecting Enabled, the external sampler is now activated.
Multiplier (2.11.4.2.) (Page 221)	1000	In this example, the LUT440 will activate the external sampler every 1000 flow units (Flowrate Units defined above during initial application setup).
Interval (2.11.4.3.) (Page 221)	24	In low flow conditions where the sampler may not activate for extended periods of time, a relay interval can be programmed to allow for sampler activation after a defined number of hours. In this example, activation should occur every 24 hours.
Relay Duration (2.11.4.4.) (Page 221)	0.2	Duration of time in seconds that the relay will energize or "tick".
Assigned Relay (2.11.4.5.) (Page 221)	Relay 2	Relay 2 has been selected for control in this example as relay 1 has been allocated to the Fail-safe alarm.
Relay Logic (2.11.4.6.) (Page 221)	Normally Open	Default for control relay functions is Normally Open. In this example, relay 2's coil will be Normally Open, and will close for 0.2 seconds.

## General Operation

This chapter provides details on the general operation and functionality of the SITRANS LUT400. For instructions on the use of the device LCD and local push buttons, refer to Local Commissioning (Page 50).

### 7.1 Starting measurement

The SITRANS LUT400 is a single point device. The device starts in LEVEL mode with a preset of no transducer and a low calibration point of 60 meters. Change the following common parameters to reflect your application.

Parameter	Sample Value
Sensor Mode (2.1.2.) (Page 173)	LEVEL
Response Rate (set via Quick Start (Page 59))	MEDIUM
Transducer (2.1.6.) (Page 174)	XPS-15
Units (2.1.1.) (Page 172)	M
Low Calibration Point (2.2.1.) (Page 176)	12
High Calibration Point (2.2.2.) (Page 176)	2

#### 7.1.1 Measurement conditions

The following information will help you configure your SITRANS LUT400 for optimal performance and reliability.

##### 7.1.1.1 Response Rate

The response rate of the device influences the measurement reliability. Use the slowest rate possible with the application requirements.

---

#### Note

Changes to fill and empty rate parameters can override Response Rate setting. See Response Rate in Quick Start Wizards (Page 58).

---

### 7.1.1.2 Dimensions

Dimensions of the vessel, wet well, or reservoir (other than low and high calibration points) are only important if you require volume readings. In this case, all dimensions are used to calculate the volume value in terms of level. They are also used to calculate pumped volume.

### 7.1.1.3 Fail-safe

The fail-safe parameters ensure that the devices controlled by the SITRANS LUT400 default to an appropriate state when a valid level reading is not available. (See list of faults that result in fail-safe in General Fault Codes (Page 273).)

- 2.4.2. LOE Timer LOE Timer (2.4.2.) (Page 179) activates if an error condition is detected. Upon expiration of the timer, the mA output value and the relay status default to values based on Material Level (2.4.1.) (Page 179).
- The fail-safe Material Level (2.4.1.) (Page 179) determines the mA output if the LOE Timer (2.4.2.) (Page 179) expires and the device is still in an error condition.

If fail-safe operation activates frequently, see Diagnosing and Troubleshooting (Page 271).

## 7.2 Relays

Relays are the primary controls of external devices such as pumps or alarms. The SITRANS LUT400 comes with extensive control and alarm functions described below.

### 7.2.1 General introduction

Three relays are provided on the SITRANS LUT400. Each relay may be independently assigned to one function (one or more functions for alarms), and has a corresponding status icon on the LCD.

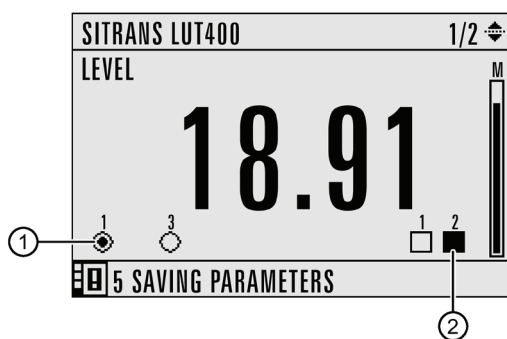

- ① Relay icons:  
 Relay 1, 3 programmed  
 Relay 2 not programmed\*  
 Relay 1 active  
 Relay 3 inactive  
 \* Icon will not display for relay or DI that is not programmed.
- ② Discrete Input icons:  
 DI 1, 2 programmed  
 DI 1 off  
 DI 2 on

Mode	Function (in normal state)
alarm	alarm ON = LCD icon ON = relay coil de-energized
pump	pump ON = LCD icon ON = relay coil energized
miscellaneous	contact closed = LCD icon ON = relay coil energized

Relay contact operation is NORMALLY CLOSED for alarms and NORMALLY OPEN for controls.

Options	Default	Alarm Contact	Pump or Control Contact
	*	Normally Closed	Normally Open
		Normally Open	Normally Closed

\* Icon will not display for relay or DI that is not programmed.

In software, all relays are programmed the same way, with ON setpoints indicating when to change the relay contact state (open or closed). Some parameters allow the reversal of the operation so that relay contacts can be NORMALLY CLOSED or NORMALLY OPEN (for example, when assigned to an alarm).

## 7.2.2 Relay function

### 7.2.2.1 Alarm

#### Level

In high alarm, the alarm state becomes active when the level rises to High Level Value ON and inactive when it falls below High Level Value OFF. In low alarm, the alarm state becomes active when the level falls to Low Level Value ON and inactive when the level rises above Low Level Value OFF.

#### In-bounds

The relay alarm becomes active if the level is inside a user-defined range.

#### Out-of-bounds

The relay alarm becomes active if the level is outside a user-defined range.

#### Temperature

In high alarm, the alarm state becomes active when the temperature rises to High Temperature Value ON and inactive when the temperature falls below High Temperature Value OFF. In low alarm, the alarm state becomes active when the temperature falls to Low Temperature Value ON and inactive when the temperature rises above Low Temperature Value OFF.

#### Switch (Discrete Input)

The relay alarm state associated with the discrete input becomes active when the discrete input is in a user-defined state.

#### Fail-safe fault

The relay alarm state becomes active when a fault that has caused a fail-safe condition is present. The relay alarm state becomes inactive when no faults that cause fail-safe are present.

## Flowrate

Available for LUT440 (OCM) model only.

In high alarm, the alarm state becomes active when the flowrate exceeds High Flowrate Value ON and inactive when the flowrate falls below High Flowrate Value OFF. In low alarm, the alarm state becomes active when the flowrate falls below Low Flowrate Value ON and inactive when the flowrate rises above Low Flowrate Value OFF.

### 7.2.2.2 Pump

#### Setpoint - ON / OFF

If the ON setpoint is higher than the OFF setpoint, the relay operates as:

- pump down control

If the ON setpoint is lower than the OFF setpoint, the relay operates as:

- pump up control

### 7.2.2.3 Miscellaneous

#### Totalizer and samplers

Refer to Other Pump Controls (Page 114). Relays are normally de-energized, contact closure is approximately 200 ms duration.

## 7.2.3 Relay behaviour under fail-safe conditions

A fail-safe condition generally indicates that the level reading is not reliable or is unknown. In such a situation, pumps will not run and alarms (that are based on level or a derivative reading) will not activate. The following describes this behaviour in detail, by relay function.

### 7.2.3.1 Alarm relays

Any alarm that is based on level, or a reading derived from level such as flow rate, will not activate if there is a fail-safe condition. If the fail-safe condition occurs and the alarm is already active, the alarm will de-activate.

The following alarm types will de-activate during a fail-safe condition:

- High Level
- Low Level
- In-bounds Level
- Out-of-bounds Level

## 7.2 Relays

- High Flow Rate
- Low Flow Rate.

---

### Note

A dedicated alarm exists for fail-safe condition as described above. See Fail-safe Fault Alarm (Page 102).

---

### 7.2.3.2 Pump relays

If a pump cycle is in progress at the time the fail-safe condition occurs, then the pump cycle will end prematurely (as if the 'off' setpoints were reached). This has the effect of turning off all pumps immediately. If a pump run-on occurrence was scheduled for the pump cycle, it will not occur. However, if a pump run-on occurrence has already begun at the time the fail-safe condition occurs, then the run-on will complete.

If no pump cycle is in progress at the time the fail-safe condition occurs, then subsequent pump cycles will not occur (the fail-safe condition will prevent pumps from starting), until the fail-safe condition is cleared.

### 7.2.3.3 Miscellaneous relays

#### External Totalizer relay

If the external totalizer is in the process of recording volume (i.e. the relay is clicking) when a fail-safe condition occurs, then the current series of clicks will be allowed to complete.

#### When totalizing volume:

Since pumps do not run when in fail-safe, then the external totalizer will in general not operate either. If a fail-safe condition occurs during a pump cycle then the volume pumped for that cycle will not be totalized.

---

### Note

A dedicated alarm exists for fail-safe condition as described above. See Fail-safe Fault Alarm (Page 102).

---

#### When totalizing OCM flow:

The flow totalizers continue to operate during a fail-safe condition, thus the external totalizer relay will also continue to operate.

#### External Sampler relay

The External Sampler relay operates the same as the External Totalizer relay described above. The periodic timeout-click will also continue to occur in fail-safe.



## Communications relays

Relays controlled by communications (HART) are not affected by a fail-safe condition.

### 7.2.4 Relay states

The relays on the SITRANS LUT400 are programmable, allowing for many control schemes.

Relay types	
	Relay 1 – NO / NC (Form C)
	Relay 2,3 – NO (Form A)

#### 7.2.4.1 Relay output logic

Affects relay reaction. Reverses the logic (normally-open to normally-closed or vice versa). Relay logic can be modified separately for alarms, and controls. (Logic for pumps cannot be reversed.)

Function		Parameter
Relay Logic (2.8.11.) (Page 210) for Alarms (2.8.) (Page 200)		Relay 1 Logic (2.8.11.1.) (Page 210) Relay 2 Logic (2.8.11.2.) (Page 210) Relay 3 Logic (2.8.11.3.) (Page 210)
Other Control (2.11.) (Page 216)	Elapsed Time Relay (2.11.1.) (Page 216)	Relay Logic (2.11.1.5.) (Page 217)
	Time of Day Relay (2.11.2) (Page 218)	Relay Logic (2.11.2.5.) (Page 219)
	External Totalizer (2.11.3) (Page 219)	Relay Logic (2.11.3.5.) (Page 220)
	External Sampler (2.11.4.) (Page 220)	Relay Logic (2.11.4.6.) (Page 221)

#### 7.2.4.2 Relay related parameters

Some parameters affect how relays react during normal conditions:

## Setpoints

When a setpoint is reached, the corresponding action is taken. The setpoint can be an ON or OFF setpoint related to a process variable, or a timed setpoint based on interval and duration.

**On and Off Setpoints**

Sets the process point at which the relay is activated (ON setpoint) then reset (OFF setpoint). These setpoints are set separately for each pump within each pump control, and for each alarm type:

Function		Parameter
Pumps (2.7.) (Page 189)	Basic Setup (2.7.1.) (Page 189)	ON Setpoint Pump 1 (2.7.1.6.) (Page 190) OFF Setpoint Pump 1 (2.7.1.7.) (Page 190) ON Setpoint Pump 2 (2.7.1.8.) (Page 190) OFF Setpoint Pump 2 (2.7.1.9.) (Page 191)
Modifiers (2.7.2.) (Page 192) (for Pumps (2.7.) (Page 189))	Energy Savings (2.7.2.2.) (Page 193)	Peak ON Setpoint Pump 1 (2.7.2.2.13.) (Page 196) Peak OFF Setpoint Pump 1 (2.7.2.2.14.) (Page 196) Peak ON Setpoint Pump 2 (2.7.2.2.15.) (Page 196) Peak OFF Setpoint Pump 2 (2.7.2.2.16.) (Page 196)
Alarms (2.8.) (Page 200)	High Level Alarm (2.8.1.) (Page 200)	High Level Value ON (2.8.1.2) (Page 200) High Level Value OFF (2.8.1.3) (Page 201)
	Low Level Alarms (2.8.2.) (Page 201)	Low Level Value ON (2.8.2.2.) (Page 201) Low Level Value OFF (2.8.2.3.) (Page 202)
	In-bounds Level Alarm (2.8.4.) (Page 203)	High Level Value (2.8.4.2.) (Page 204) Low Level Value (2.8.4.3.) (Page 204)
	Out-of-bounds Level Alarm (2.8.5.) (Page 204)	High Level Value (2.8.5.2.) (Page 205) Low Level Value (2.8.5.3.) (Page 205)
	Low Temperature Alarm (2.8.6.) (Page 205)	Low Temperature Value ON (2.8.6.2.) (Page 206) Low Temperature Value OFF (2.8.6.3.) (Page 206)
	High Temperature Alarm (2.8.7.) (Page 206)	High Temperature Value ON (2.8.7.2.) (Page 207) High Temperature Value OFF (2.8.7.3.) (Page 207)
	High Flowrate Alarm (2.8.9.) (Page 208)	High Flowrate Value ON (2.8.9.2.) (Page 208) High Flowrate Value OFF (2.8.9.3.) (Page 208)
	Low Flowrate Alarm (2.8.10.) (Page 209)	Low Flowrate Value ON (2.8.10.2.) (Page 209) Low Flowrate Value OFF (2.8.10.3.) (Page 209)

**Timed Setpoints**

Timed setpoints are based on interval, duration, or time of day. These setpoints are set separately for each pump within each pump control, and for each non-pump control function:

Function		Parameter
Modifiers (2.7.2.) (Page 192) (for Pumps (2.7.) (Page 189))	Pump Run-On (Page 197)	Run-On Interval (2.7.2.3.2.) (Page 197) Run-On Duration Pump 1 (2.7.2.3.3.) (Page 197) Run-On Duration Pump 2 (2.7.2.3.4.) (Page 197)
	Pump Start Delays (Page 197)	Delay Between Starts (2.7.2.4.1.) (Page 198) Power Resumption Delay (2.7.2.4.2.) (Page 198)
Other Control (2.11.) (Page 216)	Elapsed Time Relay (2.11.1.) (Page 216)	Interval (2.11.1.2.) (Page 217) Relay Duration (2.11.1.3.) (Page 217)
	Time of Day Relay (2.11.2) (Page 218)	Activation Time (2.11.2.2.) (Page 218) Relay Duration (2.11.2.3.) (Page 218)
	External Totalizer (2.11.3) (Page 219)	Relay Duration (2.11.3.3.) (Page 220)
	External Sampler (2.11.4.) (Page 220)	Interval (2.11.4.3.) (Page 221) Relay Duration (2.11.4.4.) (Page 221)

### 7.2.5 Relays controlled by HART Communications

A relay can be controlled directly by a remote system through communications. HART commands can be used for this purpose. An expert knowledge of HART, and the use of HART commands is recommended. For further details on configuring relays controlled by HART, contact your Siemens representative.

## 7.3 Discrete Inputs

SITRANS LUT400 has two discrete inputs to trigger or alter the way SITRANS LUT400 controls devices. A Backup Level Override, Pump Interlock, or a Switch (DI) Alarm can be configured using discrete inputs, and discrete input logic can be reversed if necessary for the application.

### 7.3.1 Backup Level Override

Backup level override provides the option of overriding the ultrasonic input (signal from a transducer) with another contacting point level device, such as the Pointek CLS200, to determine the level output.

The material reading is fixed at the programmed switch level until the discrete input is released. The LUT400 makes its decisions based on the override value.

---

#### Note

A backup level override will prevent a fail-safe condition from occurring.

---

Backup Level Override functionality is particularly useful in wet-wells and reservoirs that use pumps:

- place a backup level switch high in a vessel to indicate when it is about to overflow
- place a backup level switch low in a vessel, to indicate when it is almost empty.

### 7.3.1.1 Basic operation

Configuring Backup Level Override involves three steps (see Backup Level Override (2.9.1) (Page 211) ).

1. Select a level override value. This will be the Level output produced by the instrument when the backup level override condition is present.
2. Select the discrete input that is connected to the point-level device.
3. Enable the Backup Level Override function.

It may also be necessary to invert the logic of the discrete input, which is possible through the LUT400 discrete input logic parameters (see Discrete Input Logic (2.9.2) (Page 212) ).

### 7.3.1.2 Backup Level Override parameters

**Example:**

SITRANS LUT400 is configured for a level measurement. In the same application, Discrete Input 2 is connected to a Hi Level Backup switch at a level value of 4.3 m.

Parameter	Sample Value
Level Override Value (2.9.1.2) (Page 212)	4.3
Discrete Input Number (2.9.1.3) (Page 212)	DISCRETE INPUT 2
Enable (2.9.1.1) (Page 212)	ENABLED

When the level rises to 4.3 m and the switch is activated, the reading is forced to 4.3 m where it stays until the switch is de-activated.

### 7.3.1.3 Level Override conditions

When the discrete input activates, the level output will immediately take on the value chosen in step 1 above. The LUT400 LCD will indicate that the discrete input has been activated. When a Backup Level Override condition clears (the discrete input is deactivated), the level will return to the value determined from the ultrasonic transducer or, if no echo is available, the device will enter the fail-safe condition.

#### 7.3.1.4 Effect of Backup Level Override

The level produced by a Backup Level Override condition completely replaces the level that would otherwise be produced by normal echo processing algorithms.

This means that the Backup Level will:

- drive all readings that depend on Level (for example: space, distance, and flow)
- drive level alarms
- appear in system logs
- affect pump control
- affect totalizers (OCM and Pumped Volume)

#### 7.3.1.5 Additional considerations

When a backup level override condition is present, a fail-safe response will never occur. This allows pumps and other controls such as level alarms to be active even during the backup level override condition.

### 7.3.2 Pump Interlocks

Discrete inputs can be used to supply pump information to the SITRANS LUT400 to set actions that will occur when a pump is determined to be in a failed state.

For an example of how to configure a pump interlock, see Pump Control Interlocks (Page 113).

### 7.3.3 Switch (DI) Alarm

An alarm can be set to activate based on the state of a discrete input. See Switch (Discrete Input) Alarm (Page 102) for an example.

### 7.3.4 Discrete Input Logic

Discrete input logic affects the reaction of the discrete input. Normal state is standard operation, with the SITRANS LUT400 sensing the material level and controlling the pumps.

The contacts of the signalling device connected to the discrete inputs may be **normally open** or **normally closed**.

**Example:**

Normal state for a backup high level switch is **open**, and the contacts on the discrete input are wired as **normally open**.

This logic can also be reversed (NORMALLY OPEN to NORMALLY CLOSED or vice versa).

Use the Discrete Input logic parameters to set the state of each discrete input.

Function		Parameter
Discrete Inputs (2.9.) (Page 211)	Discrete Input Logic (2.9.2) (Page 212)	Discrete Input 1 Logic (2.9.2.1) (Page 212)
		Discrete Input 2 Logic (2.9.2.3) (Page 213)

Read the current state of discrete input 1 in Discrete Input 1 Scaled State (2.9.2.2) (Page 213) and the current state of discrete input 2 in Discrete Input 2 Scaled State (2.9.2.4) (Page 213).

See Discrete inputs (Page 45) for complete details on wiring the discrete inputs. To override a level using a discrete input, see Backup Level Override (2.9.1) (Page 211).

## 7.4 mA Control

### 7.4.1 mA output

The SITRANS LUT400 has one mA output, used for communications with other devices.

**Example:**

Configuring the mA output to send a 4 to 20 mA signal corresponding to a scaled value of 10% to 90% of maximum process level on a 60 m transducer:

Parameter	Sample Value	Description
Current Output Function (2.5.1.) (Page 180) or Current Output Function (2.5.2.) (Page 180)	LEVEL	send mA proportional to level reading
4 mA Setpoint (2.5.3.) (Page 182)	6	set 4 mA at process level equal to 10% of maximum (Low Cal minus High Cal) <sup>1</sup>
20 mA Setpoint (2.5.4.) (Page 182)	54	set 20 mA at process level equal to 90% of maximum (Low Cal minus High Cal) <sup>2</sup>
Minimum mA Limit (2.5.5.) (Page 183)	3.5	set minimum mA level below 4 mA
Maximum mA Limit (2.5.6.) (Page 183)	22.8	set maximum mA level above 20 mA

1) If the level reading drops below 6 m, the mA output drops below 4 mA.

2) If the level reading rises above 54 m, the mA output rises above 20 mA.

**Note**

If default values (4 and 20 mA) are used for the minimum and maximum mA limits, the mA output (shown in Current Output Value (2.5.8.) (Page 183)) will remain at the set mA limit, even if the level reading falls below/rises above the mA setpoints.

---

## 7.4.2 Verifying the mA range

Checks that the external device can track the entire 4 to 20 mA range sent by the SITRANS LUT400. Follow the steps below if actual mA readings differ between the LUT400 (shown in Current Output Value (2.5.8.) (Page 183)) and an external device (such as a PLC).

1. To test the loop current, set Current Output Function (2.5.2.) (Page 180) to Manual, then set the value to use in Manual Value (2.5.7.) (Page 183).
2. Check that the external device displays the same mA reading as the mA value set above.
3. If external device reading differs from the set manual value on the LUT400, adjust the reading on the external device to match the reading on the LUT400.

## 7.5 Volume

Volume is used in two situations:

1. Calculate and display volume instead of level.
2. Calculate pumped volume to accomplish the following:
  - Totalize the volume of material that is pumped out of the wet well.

### 7.5.1 Readings

When using volume, readings are given in units specified in Volume Units (2.6.2.) (Page 186).

### 7.5.2 Vessel Shape and Dimensions

There are many common vessel shapes to select from. (See Vessel Shape (2.6.1.) (Page 184). If possible, use one of these.) Each vessel shape uses the Low Calibration Point (2.2.1.) (Page 176) in its calculations of volume.

Some vessel shapes also require extra dimensions to calculate the volume. Do not estimate these values. They must be correct to ensure the accuracy of your volume calculations.

**Example:**

To configure volume for a vessel with a half-sphere bottom, set the following:

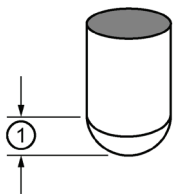

① Dimension A

Parameter	Sample Value	Description
Vessel Shape (2.6.1.) (Page 184)	HALF SPHERE BOTTOM	selects the correct vessel shape
Maximum Volume (2.6.3.) (Page 186)	100	sets maximum volume at 100 (defined in Volume Units (2.6.2.) (Page 186))
Dimension A (2.6.4.) (Page 186)	1.3	sets dimension A to 1.3 m

**Note**

- The default reading changes to a range from 0 to 100
- The process empty value is still measured to the bottom of the vessel (Low Calibration Point (2.2.1.) (Page 176) plus any Far Range (2.2.5.) (Page 177)), not the top of **Dimension A**.



### 7.5.3 Characterization chart

If you cannot use a pre-defined vessel, then use one of the universal vessel shapes and program the characterization curve.

1. Plot a volume to height chart. Usually a vessel supplier will provide this chart. However, if you have a custom-built vessel, then you will need access to complete drawings of the well or accurate measurements.
2. Enter the curve values from this chart into level and volume breakpoint tables (see Table 1-8 (2.6.7.) (Page 187)).

---

#### Note

If breakpoints are entered via LUI, then an upload is performed via PDM, a second upload through PDM may be necessary to transfer the breakpoint values.

---

3. Ensure extra points are added around sharp transitions in the vessel volume (for example: steps in a well wall).

---

#### Note

The end points in the curve are 0,0 (fixed) and the point defined by Maximum Level and Maximum Volume.

---

#### 7.5.3.1 Example chart (with 15 of possible 32 Level and Volume breakpoints defined):

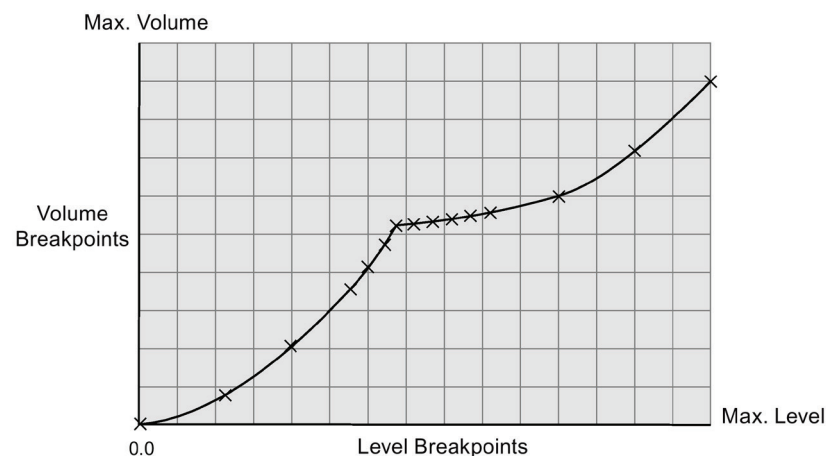

Parameter	Value	Description
Level 1	0.0	Determines the Level breakpoints at which the volumes are known.
Level 2	0.8	
Level 3	2.0	
Level 4	3.5	
Level 5	4.1	
Level 6	4.7	
Level 7	5.1	
Level 8	5.2	
Level 9	5.3	
Level 10	5.4	
Level 11	5.5	
Level 12	5.6	
Level 13	6.0	
Level 14	7.2	
Level 15	9.0	

Parameter	Value	Description	
Volume 1	0.0	Determines the volumes which correspond to the level breakpoints. The universal calculations interpret between the breakpoints to produce an accurate model of the volume at all level readings.	
Volume 2	2.1		
Volume 3	4.0		
Volume 4	5.6		
Volume 5	5.9		
Volume 6	6.3		<b>Settings</b>
Volume 7	6.7		Vessel Shape (2.6.1.) (Page 184) = LINEAR TABLE for linear approximation
Volume 8	7.1		Vessel Shape (2.6.1.) (Page 184) = CURVE TABLE for curved approximation
Volume 9	7.8		Linear approximation uses a linear algorithm; curved approximation uses a cubic spline algorithm.
Volume 10	8.2		
Volume 11	8.8		
Volume 12	9.2		
Volume 13	10.9		
Volume 14	13.0		
Volume 15	15.0		

**See also**

Level 1 (2.6.7.1.) (Page 188)

Volume 1 (2.6.7.2.) (Page 188)

## 7.6 Alarms

### 7.6.1 Set the common parameters

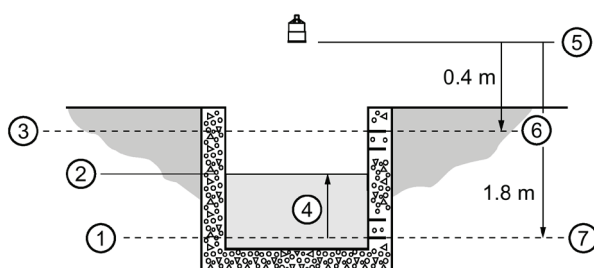

- ① Low level value
- ② Material level reading
- ④ High level value
- ⑤ Level
- ⑥ Sensor reference point
- ⑦ High calibration point

**Prerequisite:** You must know the details of your application and substitute the values for the sample values provided. If you are bench testing the device, then set your test values to be the same as the sample values.

Parameter	Description
Sensor Mode (2.1.2.) (Page 173) or Sensor Mode (2.1.3.) (Page 173)	LEVEL FLOW
Response Rate in Quick Start (Page 59)	MEDIUM
Transducer (2.1.6.) (Page 174)	XPS-10
Units (2.1.1.) (Page 172)	M
Flowrate Units (2.15.3.7.) (Page 238)	L/S
Low Calibration Point (2.2.1.) (Page 176)	1.8
High Calibration Point (2.2.2.) (Page 176)	0.4

#### Note

When configuring alarms, more than one alarm can be assigned to the same relay.

## 7.6.2 Level

The level alarm is the most common. Use this alarm to warn you when your process is in danger of being upset due to high or low levels.

High level and low level alarms can be set to activate when the material level rises above or falls below a set level. (See High Level Alarm (2.8.1.) (Page 200), Low Level Alarms (2.8.2.) (Page 201).)

### Example: Setting a High Level Alarm

To assign **Relay 3** to a high level alarm that activates when the level rises above 10 m:

1. Enable the High Level Alarm (set Enable (2.8.1.1) (Page 200) = **Enabled**)
2. Set High Level Value ON (2.8.1.2) (Page 200) = 10 m
3. Set High Level Value OFF (2.8.1.3) (Page 201) = 9 m
4. Set Assigned Relay (2.8.1.4) (Page 201) to **Relay 3**.

Use the High Level alarm in conjunction with Time To Spill (2.8.12.) (Page 211) feature.

### Example: Setting a Low Level Alarm

To assign **Relay 3** to a low level alarm that activates when the level falls below 2 m:

1. Enable the Low Level Alarm (set Enable (2.8.2.1.) (Page 201) = **Enabled**)
2. Set Low Level Value ON (2.8.2.2.) (Page 201) = 10 m
3. Set Low Level Value OFF (2.8.2.3.) (Page 202) = 9 m
4. Set Assigned Relay (2.8.2.4.) (Page 202) to **Relay 3**.

## 7.6.3 In-bounds/ Out-of-bounds Range

Use the bounded range alarms to detect when the level is inside or outside of the range.

### 7.6.3.1 Example: Setting an In-bounds Level Alarm

To assign Relay 3 to an in-bounds level alarm do the following:

1. Enable the In-bounds Level Alarm (set Enable (2.8.4.1.) (Page 203) = **Enabled**)
2. Set High Level Value (2.8.4.2.) (Page 204) = 1.30 m
3. Set Low Level Value (2.8.4.3.) (Page 204) = 0.30 m
4. Set Assigned Relay (2.8.4.4.) (Page 204) to **Relay 3**.

#### Results:

- Activates alarm assigned to relay 3 when level is within range 0.3 to 1.3 m
- Resets alarm above 1.3 m or below 0.3 m

Use Alarm State (2.8.4.5.) (Page 204) to view the current state of the In-bounds Level Alarm.

### 7.6.3.2 Example: Setting an Out-of-bounds Level Alarm

To assign Relay 3 to an out-of-bounds level alarm do the following:

1. Enable the Out-of-bounds Level Alarm (set Enable (2.8.5.1.) (Page 204) = **Enabled**)
2. Set High Level Value (2.8.5.2.) (Page 205) = 1.30 m
3. Set Low Level Value (2.8.5.3.) (Page 205) = 0.30 m
4. Set Assigned Relay (2.8.5.4.) (Page 205) to **Relay 3**.

#### Results:

- Activates alarm assigned to relay 3 when level is outside range 0.3 to 1.3 m
- Resets alarm below 1.3 m or below 0.3 m

Use Alarm State (2.8.5.5.) (Page 205) to view the current state of the Out-of-bounds Level Alarm.

## 7.6.4 Temperature

Activates an alarm when the process temperature reaches a certain value (Low Temperature Value ON for Low Temperature Alarm or High Temperature Value ON for a High Temperature Alarm).

The temperature source can be the temperature sensor built into the transducer or an external TS-3, as set by Temperature Source. (Temperature Source is set in the Quick Start (Page 59).)

### Example: Setting a High Temperature Alarm

To assign Relay 3 to a high temperature alarm that activates when the temperature goes above 30 °C do the following:

1. Enable the High Temperature Alarm (set Enable (2.8.7.1.) (Page 206) = **Enabled**)
2. Set High Temperature Value ON (2.8.7.2.) (Page 207) = **30**
3. Set High Temperature Value OFF (2.8.7.3.) (Page 207) = **28**
4. Set Assigned Relay (2.8.7.4.) (Page 207) to **Relay 3**.

The high temperature alarm will not de-activate until the temperature falls to 28 °C.

Use Alarm State (2.8.7.5.) (Page 207) to view the current state of the High Temperature Alarm.

**Example: Setting a Low Temperature Alarm**

To assign Relay 3 to a low level alarm that activates when the temperature falls below -10 °C do the following:

1. Enable the Low Temperature Alarm (set Enable (2.8.6.1.) (Page 205) = **Enabled**)
2. Set Low Temperature Value ON (2.8.6.2.) (Page 206) = **-10**
3. Set Low Temperature Value OFF (2.8.6.3.) (Page 206) = **-8**
4. Set Assigned Relay (2.8.6.4.) (Page 206) to **Relay 3**.

Use Alarm State (2.8.6.5.) (Page 206) to view the current state of the Low Temperature Alarm.

**7.6.5 Switch (Discrete Input) Alarm**

Activates an alarm when a discrete input is in a pre-defined state.

**Example: Setting a Switch Alarm**

To assign Relay 3 to a switch alarm that is activated when DI 1 turns ON do the following:

1. Enable the Switch (Discrete Input) Alarm (set Enable (2.8.3.1.) (Page 202) = **Enabled**)
2. Set the Discrete Input Number (2.8.3.2.) (Page 202) = **1**
3. Set Discrete Input State (2.8.3.3.) (Page 203) to **ON**.
4. Set Assigned Relay (2.8.3.4.) (Page 203) to **Relay 3**.

Use Alarm State (2.8.3.5.) (Page 203) to view the current state of the Switch Alarm.

**7.6.6 Fail-safe Fault Alarm**

Activates an alarm when a fault that has caused a fail-safe condition is present.

**Example: Setting a Fail-safe Fault Alarm**

To assign a fail-safe fault alarm to Relay 3 do the following:

1. Enable the Fail-safe Fault Alarm (set Enable (2.8.8.1.) (Page 207) = **Enabled**)
2. Set Assigned Relay (2.8.8.2.) (Page 208) to **Relay 3**.

Use Alarm State (2.8.8.3.) (Page 208) to view the current state of the Fail-safe Alarm.

**7.6.7 Flowrate**

Flowrate alarms are available on LUT440 (OCM) model only. They can activate an alarm if the OCM flowrate is above or below a given setpoint.

**Example: Setting a High Flowrate Alarm**

To assign Relay 3 to a high flowrate alarm that activates when the flowrate rises above 10 l/s:

1. Enable the High Flowrate Alarm (set Enable (2.8.9.1.) (Page 208) = **Enabled**).
2. Set High Flowrate Value ON (2.8.9.2.) (Page 208) = **10**
3. Set High Flowrate Value OFF (2.8.9.3.) (Page 208) = **8**
4. Set Assigned Relay (2.8.9.4.) (Page 209) to **Relay 3**

**Example: Setting a Low Flowrate**

Alarm To assign Relay 3 to a low level alarm that activates when the flowrate falls below 2 l/s:

1. Enable the Low Flowrate Alarm (set Enable (2.8.10.1.) (Page 209) = **Enabled**)
2. Set Low Flowrate Value ON (2.8.10.2.) (Page 209) = **2**
3. Set Low Flowrate Value OFF (2.8.10.3.) (Page 209) = **4**
4. Set Assigned Relay (2.8.10.4.) (Page 210) to **Relay 3**

## 7.7 Pump Control

The SITRANS LUT400 has the pump control functionality to solve nearly any water/waste water application. To set up pump control for simple applications, see *Pump Control Wizard* in LUT400 Communications manual<sup>1</sup>.

<sup>1</sup>) Communications for SITRANS LUT400 (HART) Manual (7ML19985NE01)

### 7.7.1 Pump Control options

Methods of pump control are dependent on two variables:

*Pump start method* indicates in what sequence pumps are started; using Fixed, Alternate, or Service Ratio setpoints.

*Pump duty* indicates whether new pumps start and run with any currently running pumps (most common) or whether new pumps start and shut off currently running pumps; using Assist or Backup duty.

#### 7.7.1.1 Pump Control algorithms

Algorithms are used to provide six modes of pump control. They can be used to start multiple pumps (assist) or one pump at a time (backup). These six modes can be grouped into three main methods of pump control used by the SITRANS LUT400: Fixed, Alternate, and Service Ratio. The LUT420 (Level) model operates with Alternate pump control only.

**Fixed**

Starts pumps based on individual setpoints and always starts the same pumps in the same sequence [Fixed Duty Assist (FDA), and Fixed Duty Backup (FDB)].

**Alternate**

Starts pumps based on the duty schedule and always leads with a new pump [Alternate Duty Assist (ADA), and Alternate Duty Backup (ADB)].

**Service Ratio**

Starts pumps based on user-defined ratio of running time [Service Ratio Duty Assist (SRA), and Service Ratio Duty Backup (SRB)].

Alternate Duty Assist (ADA) is set as the default.

**7.7.2 Setting a pump down (wet well) group**

Setting a group of two pumps to pump down a wet well.

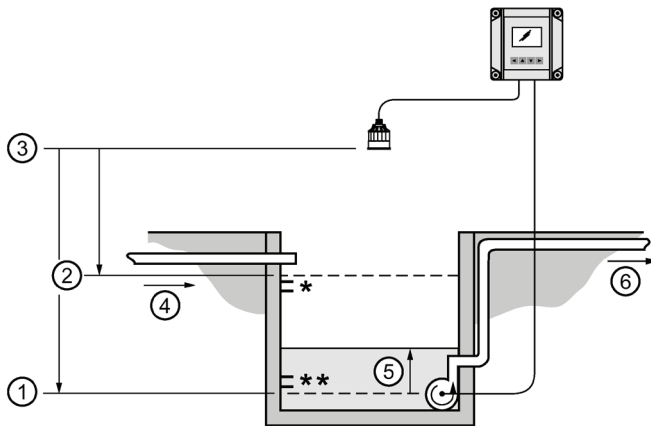

- ① Low calibration point
  - ② High calibration point
  - ③ Sensor reference point
  - ④ Inflow
  - ⑤ Level
  - ⑥ Outflow
- \* ON Setpoint Pump 1 / Pump 2
- \*\* OFF Setpoint Pump 1 / Pump 2



### 7.7.2.1 Set the common parameters

**Prerequisite:** Substitute the details of your application in place of the sample values provided. If you are bench testing the device, set your test values to be the same as the sample values.

Parameter	Sample Value
Sensor Mode (2.1.2.) (Page 173)	Level
Response Rate in Quick Start (Page 59)	Medium
Transducer (2.1.6.) (Page 174)	XPS-10
Units (2.1.1.) (Page 172)	M
Low Calibration Point (2.2.1.) (Page 176)	1.8
High Calibration Point (2.2.2.) (Page 176)	0.4

### 7.7.2.2 Set Relays to ALTERNATE DUTY ASSIST (ADA)

Parameter	Value	Description
Pump Control Mode (2.7.1.4.) (Page 189) or Pump Control Mode (2.7.1.5.) (Page 189)	ADA	Sets the control algorithm used to trip the pump relay to ALTERNATE DUTY ASSIST. Multiple pumps can run simultaneously.

### 7.7.2.3 Set the ON Setpoints

Parameter	Sample Value <sup>1</sup>	Description
ON Setpoint Pump 1 (2.7.1.6.) (Page 190)	1.0 m*	Sets the level at which pump 1 turns on. The first cycle will use this setpoint. Subsequent cycles rotate the setpoint among the pumps. For example: In cycle 1, pump 1 turns on at 1 m. In the next cycle, pump 2 will turn on at 1 m.
ON Setpoint Pump 2 (2.7.1.8.) (Page 190)	1.1 m*	Sets the level at which pump 2 turns on.

<sup>1)</sup> Sample values denoted by asterisks in illustration on Setting a pump down (wet well) group (Page 104).

### 7.7.2.4 Set the OFF Setpoints

Parameter	Sample Value <sup>1</sup>	Description
OFF Setpoint Pump 1 (2.7.1.7.) (Page 190)	0.5 m**	Sets the level at which pump 1 turns off. The first cycle will use this setpoint. Subsequent cycles rotate the setpoint among the pumps. For example: In cycle 1, pump 1 turns off at 0.5 m. In the next cycle, pump 2 will turn off at 0.5 m.
OFF Setpoint Pump 2 (2.7.1.9.) (Page 191)	0.6 m**	Sets the level at which pump 2 turns off.

<sup>1</sup>) Sample values denoted by asterisks in illustration on Setting a pump down (wet well) group (Page 104).

### 7.7.3 Other Pump Control algorithms

#### 7.7.3.1 Set Relays to ALTERNATE DUTY BACKUP (ADB)

Parameter	Value	Description
Pump Control Mode (2.7.1.4.) (Page 189) or Pump Control Mode (2.7.1.5.) (Page 189)	ADB	Sets the control algorithm used to trip the pump relay to ALTERNATE DUTY BACKUP. Only one pump can run at a time.

### Set the ON Setpoints

Parameter	Sample Value	Description
ON Setpoint Pump 1 (2.7.1.6.) (Page 190)	1.3 m*	Sets the level at which pump 1 turns on. The first cycle will use this setpoint. Subsequent cycles rotate the setpoint among the pumps.
ON Setpoint Pump 2 (2.7.1.8.) (Page 190)	1.2 m*	Sets the level at which pump 2 turns on.

## Set the OFF Setpoints

Parameter	Sample Value	Description
OFF Setpoint Pump 1 (2.7.1.7.) (Page 190)	0.4 m**	Sets the level at which pump 1 turns off. The first cycle will use this setpoint. Subsequent cycles rotate the setpoint among the pumps.
OFF Setpoint Pump 2 (2.7.1.9.) (Page 191)	0.3 m**	Sets the level at which pump 2 turns off.

### 7.7.3.2 Set Relays to FIXED DUTY ASSIST (FDA)

Parameter	Value	Description
Pump Control Mode (2.7.1.5.) (Page 189)	FDA	Sets the control algorithm used to trip the pump relay to <b>FIXED DUTY ASSIST</b> . Only one pump can run at a time.

## Set the ON Setpoints

Parameter	Sample Value	Description
ON Setpoint Pump 1 (2.7.1.6.) (Page 190)	1.3 m	Sets the level at which pump 1 turns on.
ON Setpoint Pump 2 (2.7.1.8.) (Page 190)	1.2 m	Sets the level at which pump 2 turns on.

## Set the OFF Setpoints

Parameter	Sample Value	Description
OFF Setpoint Pump 1 (2.7.1.7.) (Page 190)	0.4 m	Sets the level at which pump 1 turns off.
OFF Setpoint Pump 2 (2.7.1.9.) (Page 191)	0.3 m	Sets the level at which pump 2 turns off.

### 7.7.3.3 Set Relays to FIXED DUTY BACKUP (FDB)

Parameter	Value	Description
Pump Control Mode (2.7.1.5.) (Page 189)	FDB	Sets the control algorithm used to trip the pump relay to <b>FIXED DUTY BACKUP</b> . Only one pump can run at a time.

### Set the ON Setpoints

Parameter	Sample Value	Description
ON Setpoint Pump 1 (2.7.1.6.) (Page 190)	1.3 m	Sets the level at which pump 1 turns on.
ON Setpoint Pump 2 (2.7.1.8.) (Page 190)	1.2 m	Sets the level at which pump 2 turns on.

### Set the OFF Setpoints

Parameter	Sample Value	Description
OFF Setpoint Pump 1 (2.7.1.7.) (Page 190)	0.4 m	Sets the level at which pump 1 turns off.
OFF Setpoint Pump 2 (2.7.1.9.) (Page 191)	0.3 m	Sets the level at which pump 2 turns off.

#### 7.7.3.4 Set Relays to SERVICE RATIO DUTY ASSIST (SRA)

Parameter	Value	Description
Pump Control Mode (2.7.1.5.) (Page 189)	SRA	Sets the control algorithm used to trip the pump relay to <b>SERVICE RATIO DUTY ASSIST</b> . Multiple pumps can run simultaneously. Pump usage is based on RUN time rather than last used.
Service Ratio Pump 1 (2.7.1.10.) (Page 191)	25	Sets the ratio to: 25% for pump 1, i.e. pump 1 will run 25% of the time.
Service Ratio Pump 2 (2.7.1.11.) (Page 191)	75	Sets the ratio to: 75% for pump 2, i.e. pump 2 will run 75% of the time

### Set the ON Setpoints

Parameter	Sample Value	Description
ON Setpoint Pump 1 (2.7.1.6.) (Page 190)	1.3 m	Sets the level at which pump 1 turns on.
ON Setpoint Pump 2 (2.7.1.8.) (Page 190)	1.2 m	Sets the level at which pump 2 turns on setpoints

## Set the OFF Setpoints

Parameter	Sample Value	Description
OFF Setpoint Pump 1 (2.7.1.7.) (Page 190)	0.4 m	Sets the level at which pump 1 turns off.
OFF Setpoint Pump 2 (2.7.1.9.) (Page 191)	0.3 m	Sets the level at which pump 2 turns off.

### 7.7.3.5 Set Relays to SERVICE RATIO DUTY BACKUP (SRB)

Parameter	Value	Description
Pump Control Mode (2.7.1.5.) (Page 189)	SRB	Sets the control algorithm used to trip the pump relay to <b>SERVICE RATIO DUTY BACKUP</b> . Only one pump can run at a time. Pump usage is based on RUN time rather than last used.

## Set the Service Ratio for each pump

Parameter	Value	Description
Service Ratio Pump 1 (2.7.1.10.) (Page 191)	25	Sets the ratio to: 25% for pump 1, i.e. pump 1 will run 25% of the time.
Service Ratio Pump 2 (2.7.1.11.) (Page 191)	75	Sets the ratio to: 75% for pump 2, i.e. pump 2 will run 75% of the time.

## Set the ON Setpoints

Parameter	Sample Value	Description
ON Setpoint Pump 1 (2.7.1.6.) (Page 190)	1.3 m	Sets the level at which pump 1 turns on.
ON Setpoint Pump 2 (2.7.1.8.) (Page 190)	1.2 m	Sets the level at which pump 2 turns on.

**Set the OFF Setpoints**

Parameter	Sample Value	Description
OFF Setpoint Pump 1 (2.7.1.7.) (Page 190)	0.4 m	Sets the level at which pump 1 turns off.
OFF Setpoint Pump 2 (2.7.1.9.) (Page 191)	0.3 m	Sets the level at which pump 2 turns off.

---

**Note**

- The SITRANS LUT400 will not sacrifice other pumping strategies to ensure that the service ratio is held true.
  - If the pump ratios are set to the same value, then the ratio equals 1:1 and all pumps are used equally (default).
- 

When a pump start is required (ON Setpoint), the pump with the fewest running hours (with respect to the assigned ratio values) starts.

Conversely, when a pump stop is required (OFF Setpoint), if multiple pumps are running simultaneously, the pump with the most running hours (as compared to the assigned ratio values) stops.

### 7.7.4 Setting a pump up (reservoir) group

Sets a group of two pumps to pump up a reservoir.

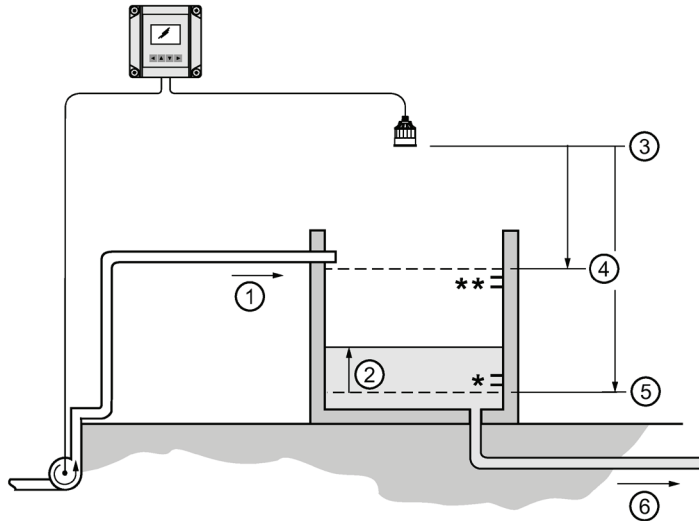

- ① Inflow
- ② Level
- ③ Sensor reference point
- ④ High calibration point
- ⑤ Low calibration point
- ⑥ Outflow

\* ON Setpoint Pump 1 / Pump 2

\*\* OFF Setpoint Pump 1 / Pump 2

#### 7.7.4.1 Set the common parameters

**Prerequisite:** Substitute the details of your application in place of the sample values provided. If you are bench testing the device, set your test values to be the same as the sample values.

Parameter	Sample Value
Sensor Mode (2.1.2.) (Page 173) or Sensor Mode (2.1.3.) (Page 173)	Level
Response rate in Quick Start (Page 59)	Medium
Transducer (2.1.6.) (Page 174)	XPS-10
Units (2.1.1.) (Page 172)	M
Low Calibration Point (2.2.1.) (Page 176)	1.8
High Calibration Point (2.2.2.) (Page 176)	0.4

### 7.7.4.2 Set Relays to ALTERNATE DUTY ASSIST (ADA)

Parameter	Value	Description
Pump Control Mode (2.7.1.4.) (Page 189) or Pump Control Mode (2.7.1.5.) (Page 189)	ADA	Sets the control algorithm used to trip the pump relay to <b>ALTERNATE DUTY ASSIST</b> .

### 7.7.4.3 Set the ON Setpoints

Parameter	Sample Value <sup>1</sup>	Description
ON Setpoint Pump 1 (2.7.1.6.) (Page 190)	0.4 m*	Sets the level at which pump 1 turns on. The first cycle will use this setpoint. Subsequent cycles rotate the setpoint among the pumps. For example: In cycle 1, pump 1 turns on at 0.4 m. In the next cycle, pump 2 will turn on at 0.4 m.
ON Setpoint Pump 2 (2.7.1.8.) (Page 190)	0.3 m*	Sets the level at which pump 2 turns on.

<sup>1)</sup> Sample values denoted by asterisks in illustration on Setting a pump up (reservoir) group (Page 111)

### 7.7.4.4 Set the OFF Setpoints

Parameter	Sample Value <sup>1</sup>	Description
OFF Setpoint Pump 1 (2.7.1.7.) (Page 190)	1.3 m**	Sets the level at which pump 1 turns off. The first cycle will use this setpoint. Subsequent cycles rotate the setpoint among the pumps. For example: In cycle 1, pump 1 turns off at 1.3 m. In the next cycle, pump 2 will turn off at 1.3 m.
OFF Setpoint Pump 2 (2.7.1.9.) (Page 191)	1.2 m**	Sets the level at which pump 2 turns off.

<sup>1)</sup> Sample values denoted by asterisks in illustration on Setting a pump up (reservoir) group (Page 111).



## 7.7.5 Pump Control Interlocks

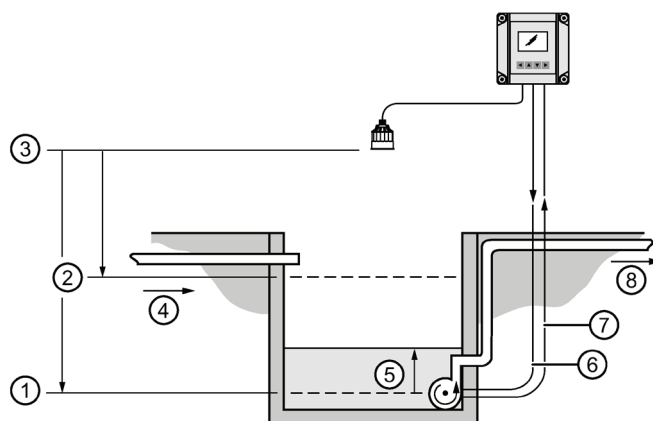

- ① Low calibration point
- ② High calibration point
- ③ Sensor reference point
- ④ Inflow
- ⑤ Level
- ⑥ Relay output
- ⑦ Discrete input
- ⑧ Outflow

Parameter	Sample Value	Description
Pump Control Mode (2.7.1.4.) (Page 189) or Pump Control Mode (2.7.1.5.) (Page 189)	ADA	Sets the control algorithm used to trip the pump relay to <b>ALTERNATE DUTY ASSIST</b> .
Enable Pump 1 (2.9.3.1) (Page 213)	ON	Enables pump start interlock for Pump 1.
Pump 1 Discrete Input (2.9.3.2) (Page 213)	Discrete Input 1	Sets the discrete input to use for pump start interlock on Pump 1.
Enable Pump 2 (2.9.3.3) (Page 214)	ON	Enables pump start interlock for Pump 2.
Pump 2 Discrete Input (2.9.3.4) (Page 214)	Discrete Input 2	Sets the discrete input to use for pump start interlock on Pump 2.
Discrete Input 1 Logic (2.9.2.1) (Page 212)	Normally Closed	Use if necessary to reverse logic for Discrete Input 1.
Discrete Input 2 Logic (2.9.2.3) (Page 213)	Normally Closed	Use if necessary to reverse logic for Discrete Input 2.

These values will ensure that any pump reporting a failure is removed from the pumping rotation. For more information on pump interlocks and discrete inputs, see Discrete Inputs (Page 91).

## 7.7.6 Other Pump Controls

**Prerequisite:** Common parameters must first be set for each pump control below:

Parameter	Description
Sensor Mode (2.1.2.) (Page 173) or Sensor Mode (2.1.3.) (Page 173)	Volume
Response rate in Quick Start (Page 59)	Medium
Transducer (2.1.6.) (Page 174)	XPS-10
Units (2.1.1.) (Page 172)	M
Low Calibration Point (2.2.1.) (Page 176)	1.8
High Calibration Point (2.2.2.) (Page 176)	0.4

### 7.7.6.1 Totalizing pumped volume

Available only on LUT430 (Pump and Flow model), and LUT440 (OCM model).

**Prerequisite:** The volume of the vessel must be known.

Parameter	Sample Value	Description
Vessel Shape (2.6.1.) (Page 184)	LINEAR	Vessel shape is linear (flat bottom)
Maximum Volume (2.6.3.) (Page 186)	17.6	Max volume is 17.6m <sup>3</sup> or 17,600 liters.
Pump Control Mode (2.7.1.4.) (Page 189) or Pump Control Mode (2.7.1.5.) (Page 189)	ADA	Sets the control algorithm used to trip the pump relay to <b>ALTERNATE DUTY ASSIST</b> .
ON Setpoint Pump 1 (2.7.1.6.) (Page 190)	1.0 m	Sets the level at which pump 1 turns on. The first cycle will use this setpoint. Subsequent cycles rotate the setpoint among the pumps.
ON Setpoint Pump 2 (2.7.1.8.) (Page 190)	1.2 m	Sets the level at which pump 2 turns on.
OFF Setpoint Pump 1 (2.7.1.7.) (Page 190)	0.2 m	Sets the level at which pump 1 turns off. The first cycle will use this setpoint. Subsequent cycles rotate the setpoint among the pumps.
OFF Setpoint Pump 2 (2.7.1.9.) (Page 191)	0.3 m	Sets the level at which pump 2 turns off.
Totalizer Decimal Position (2.7.3.2.) (Page 199)	2 DIGITS	Sets the totalizer display to 2 digits.
Totalizer Multiplier (2.7.3.3.) (Page 199)	1000	Actual volume is divided by 1000, prior to display on LCD.
Inflow/Discharge Adjust (2.7.3.4.) (Page 199)	RATE ESTIMATE	The inflow rate measured just prior to the start of the pump cycle is used to estimate the inflow for the duration of the cycle.

1. Display vessel volume on the LCD (set parameter Sensor Mode (2.1.2.) (Page 173) to VOLUME).
2. Toggle to SV on LCD to display current level (set parameter Sensor Mode Secondary (2.1.4.) (Page 174) to LEVEL).
3. See Running Totalizer (2.7.3.1.) (Page 198) to view pumped volume.

### 7.7.6.2 Setting a pump to run-on

This functionality is used to reduce sludge and sediment from building up at the bottom of a wet well, thereby reducing maintenance. This is achieved by running the pumps below the normal OFF setpoint and requires you to set a run-on duration and interval to control this event.

#### Example:

Pump 1 is set to pump for an extra 60 seconds every 5 hours, pump 2 should not run-on.

Parameter	Sample Value	Description
Run-On Interval (2.7.2.3.2.) (Page 197)	5	Five hours between pump run-on occurrences.
Run-On Duration Pump 1 (2.7.2.3.3.) (Page 197)	60	The pump will run-on for 60 seconds.
Run-On Duration Pump 2 (2.7.2.3.4.) (Page 197)	0	Pump 2 will never run-on.

### 7.7.6.3 Setting the pump start delays

In the event that power to the SITRANS LUT400 has been lost, the pump start delay ensures that all of the pumps do not start at once to avoid power surges. There are two parameters used here: Pump Start Delay and Power Resumption Delay.

#### Example:

The delay between pumps is set to 20 seconds and the delay of the first pump is set to 60 seconds.

Parameter	Sample Value	Description
Delay Between Starts (2.7.2.4.1.) (Page 198)	20	Wait at least 20 seconds between pump starts.
Power Resumption Delay (2.7.2.4.2.) (Page 198)	60	Wait for 60 seconds when power is restored for the first pump to activate.

### 7.7.6.4 Reducing wall cling

Use the Wall Cling Reduction function to randomly alter the ON and OFF setpoints over a range. This eliminates the ridge of material that builds up at the setpoint that can give false echoes.

This setting may increase the number of days between trips to clean the wet well.

Enable Wall Cling Reduction by setting Enable (2.7.2.1.1) (Page 192) = Enabled. Then set the range in Level Setpoint Variation (2.7.2.1.2) (Page 192). The pump ON and OFF setpoints are randomly varied inside this range so the material level does not stop at the same point each time.

**Example:**

A range of 0.5 meters is used to vary the setpoint. The randomly-selected setpoints are always inside the ON and OFF setpoints.

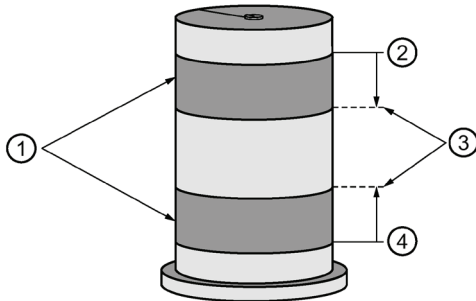

- ① Random setpoint range
- ② ON setpoint
- ③ Level setpoint variation
- ④ OFF setpoint

**7.7.6.5 Saving energy**

Pumps can use different setpoints at different times of the day to account for variable energy costs.

The following example illustrates high energy cost usage reduction and/or elimination by using the SITRANS LUT400 Energy Savings function on a wet well (pump down application) using pump 1.

**Pre-requisite:** enable Energy Savings function (set Enable (2.7.2.2.1.) (Page 193) = Enabled)

<p>15:30 (3:30 pm)</p>	<p><b>Normal Operation</b> Uses the standard ON and OFF setpoints (ON Setpoint Pump 1 (2.7.1.6.) (Page 190)/ OFF Setpoint Pump 1 (2.7.1.7.) (Page 190)). Energy cost is at minimum.</p>
<p>16:30 (4:30 pm)</p>	<p><b>Peak Lead Time (2.7.2.2.2.) (Page 193) = 60 minutes.</b> Pumps down the wet well regardless of the pump ON Setpoints. This ensures that the wet well starts the high cost period at the OFF Setpoint Pump 1 (2.7.1.7.) (Page 190). Energy cost is at minimum.</p>
<p>17:30 (5:30 pm)</p>	<p><b>Peak 1 Start Time (2.7.2.2.3.) (Page 193) = 17:30.</b> Starts using the energy savings setpoints (Peak ON Setpoint Pump 1 (2.7.2.2.13.) (Page 196) and Peak OFF Setpoint Pump 1 (2.7.2.2.14.) (Page 196)).</p>
<p>21:30</p>	<p>Energy cost is at maximum.</p>

1. 8 m (ON setpoint)	Peak 1 End Time (2.7.2.2.4.) (Page 194) = 21:30. Returns to normal setpoints (ON Setpoint Pump 1 (2.7.1.6.) (Page 190) / OFF Setpoint Pump 1 (2.7.1.7.) (Page 190)). Energy cost returns to minimum.
2. 2 m (OFF setpoint)	
3. 9 m (Peak ON)	
4. 8 m (ON setpoint)	
5. 6 m (Peak OFF)	
6. 2 m (OFF setpoint)	

Generally, you would cascade the timing of the pump downs so that the wells farthest from the treatment facility would begin first and the entire system would push material through during the low cost period.

#### Note

When the Peak ON Setpoint is not reached, no energy is used during the high cost period. If the Peak ON Setpoint is reached, the Wet Well is only pumped down to 6 m, thereby minimizing high cost energy usage.

Parameter	Sample Value	Description
Enable (2.7.2.2.1.) (Page 193)	Enabled	Enables Energy Savings function
Peak 1 Start Time (2.7.2.2.3.) (Page 193)	17:30	Starts the first high cost period at 5:30 pm
Peak 1 End Time (2.7.2.2.4.) (Page 194)	21:30	Ends the first high cost period at 9:30 pm
Peak Lead Time (2.7.2.2.2.) (Page 193)	00:60	Sets the pump down to happen 60 minutes before the high cost period
Peak ON Setpoint Pump 1 (2.7.2.2.13.) (Page 196)	9	Sets the high cost ON setpoint at process level of 9 m
Peak OFF Setpoint Pump 1 (2.7.2.2.14.) (Page 196)	6	Sets the high cost OFF setpoint at process level of 6 m

### 7.7.6.6 Tracking pump usage

You can find out how much an individual pump has been used by viewing the pump record parameters.

Information Available	Parameter Access
Total running hours for a relay assigned to a pump.	Run Time Relay 2 (3.2.7.1.) (Page 248) Run Time Relay 3 (3.2.7.2.) (Page 248)

## 7.8 Other controls

### 7.8.1 Relays controlled by time

A relay can be controlled by time setpoints using Time of Day or Elapsed Time.

#### Set Time of Day Relay

Parameter	Value	Description
Enable (2.11.2.1.) (Page 218)	Enabled	Enables Time of Day Relay
Activation Time (2.11.2.2.) (Page 218)	17:30	Activates the relay at 5:30 pm
Relay Duration (2.11.2.3.) (Page 218)	60	Activates the relay for 60 seconds
Assigned Relay (2.11.2.4.) (Page 218)	Relay 1	Sets relay 1 to be controlled by time of day
Relay Logic (2.11.2.5.) (Page 219)	Normally Closed	Use (if necessary) to change the behaviour of the relay assigned to the time of day control. Default: Normally Open

#### Set Elapsed Time Relay

Parameter	Value	Description
Enable (2.11.1.1.) (Page 217)	Enabled	Enables elapsed time relay
Interval (2.11.1.2.) (Page 217)	24	Activates the relay every 24 hours
Relay Duration (2.11.1.3.) (Page 217)	60	Activates the relay for 60 seconds
Assigned Relay (2.11.1.4.) (Page 217)	Relay 1	Sets relay 1 to be controlled by elapsed time
Relay Logic (2.11.1.5.) (Page 217)	Normally Closed	Use (if necessary) to change the behaviour of the relay assigned to the elapsed time control. Default: Normally Open

## 7.9 Flow

### 7.9.1 Flow calculation

The SITRANS LUT400 provides numerous open channel flow calculation features (see Flow (2.15.) (Page 234)).

The device can be configured to select the flow calculation specific to the primary measuring device (PMD), such as a flume or weir. If the PMD does not match any of the eleven preset PMD calculations, a universal flow calculation can be used (PMD = Universal Head Flow). See Flow Calculation (Page 306) for more details.

The SITRANS LUT400 converts the head measurement into flow rate. The flow rate is totaled and stored in a comprehensive data log to facilitate detailed flow analysis.

### 7.9.2 Totalizing flow

Totalizing of the calculated flow is ongoing. Daily and running totalizers can be viewed in Totalizers (2.16.) (Page 242). The daily totalizer resets automatically every 24 hours at 23:59:59, and both can be reset by the user.

In order to adjust the rate of filling of the totalizer, the Totalizer Multiplier (2.7.3.3.) (Page 199) can be set to an appropriate value. Totalizing that is specific to a time and date can be viewed under View Logs for flow (see OCM (3.2.6.2.) (Page 248)).

---

#### Note

If power is lost to the LUT400, totalizer values may also be lost. Totalizer values are only written to non-volatile memory once every hour.

---

The SITRANS LUT400 can be programmed to operate a remote totalizer by assigning any of the relays to act as a totalizer contact. Under this function, the maximum rate of contact closure is 5/s with a closure duration of 100 ms.<sup>1</sup>

<sup>1</sup>) Typically the totalizer should be set for 300 to 3000 counts per day at maximum flow.

## 7.10 External Totalizers and Flow Samplers

External totalizers are simple counters which count the number of relay clicks produced by the SITRANS LUT400. This is generally used to keep track of OCM or pumped volume totals. Note that both of these values are also stored in the SITRANS LUT400 and are available through communications.

Flow samplers are devices which take a sample of liquid when triggered by a relay click. These samples are used to monitor water quality over time. Flow samplers can be driven by OCM volume, pumped volume, or by time depending on the application requirements.

### 7.10.1 Relay contacts

Pumped volume is calculated at the end of the pump cycle. Totalized volume when External Totalizer (2.11.3) (Page 219) function is enabled will be given in bursts at the end of the pump cycle, not throughout the pump cycle.

Use Relay Duration (2.11.3.3.) (Page 220) to set the time in seconds from one change of state in the relay to the next. This parameter sets both the open and closed times for the relay contact and is preset to 0.2 seconds. Partial units are added to the next pump cycle.

#### Example:

Shows a relay set up to make one contact for every cubic metre (m<sup>3</sup>) of liquid.

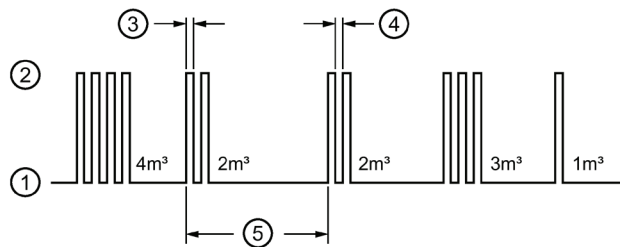

- ① Relay contact open
- ② Relay contact closed
- ③ Relay duration ON time
- ④ Relay duration OFF time
- ⑤ Pump cycle

The following parameters describe how to setup a Totalizer or Sampler.



## 7.10.2 Totalizer

Use the External Totalizer (2.11.3) (Page 219) function to set the totalizer to provide relay contact to an external counter.

Counter Formula	
1 contact every x units, where x = value set in Multiplier (2.11.3.2.) (Page 219)	Multiplier (2.11.3.2.) (Page 219) is preset to 1 so the default number of contacts is one contact per unit of volume.
<b>Example:</b> To click once every 4310 units, set Multiplier (2.11.3.2.) (Page 219) to 4310.	

The totalizer source, and units depend on the volume configuration:

Volume Configuration	Totalizer Source	Units Source
Vessel Shape (2.6.1.) (Page 184) = NONE	Totalizers (2.16.) (Page 242)	Flowrate Units (2.15.3.7.) (Page 238)
Vessel Shape (2.6.1.) (Page 184) = any setting other than NONE	Totalizers (2.7.3.) (Page 198)	Volume Units (2.6.2.) (Page 186)

Parameter	Value	Description
Enable (2.11.3.1.) (Page 219)	Enabled	Enables External Totalizer Relay
Multiplier (2.11.3.2.) (Page 219)	4310	Click once every 4310 units
Relay Duration (2.11.3.3.) (Page 220)	0.2	Activates the relay for 0.2 seconds
Assigned Relay (2.11.3.4.) (Page 220)	Relay 1	Sets relay 1 to be controlled by external totalizer
Relay Logic (2.11.3.5.) (Page 220)	Normally Closed	Use (if necessary) to change the behaviour of the relay assigned to the totalizer. Default: Normally Open

### Note

#### Ensure proper counting output

In case of running totalizers when a change is required, cycle the power to ensure proper counting output of the relay between parameter settings.

### 7.10.3 Flow Sampler

Use the External Sampler (2.11.4.) (Page 220) function to activate the flow sampler relay based on volume and time.

Counter Formula	
1 contact every x units, where x = value set in Multiplier (2.11.4.2.) (Page 221)	Multiplier (2.11.4.2.) (Page 221) is preset to 1 so the default number of contacts for a pumped volume cycle is one contact per unit of volume.
<b>Example:</b> To click once every 4310 units, set Multiplier (2.11.4.2.) (Page 221) to 4310.	

The totalizer source, and units depend on the volume configuration:

Volume Configuration	Totalizer Source	Units Source
Vessel Shape (2.6.1.) (Page 184) = NONE	Totalizers (2.16.) (Page 242)	Flowrate Units (2.15.3.7.) (Page 238)
Vessel Shape (2.6.1.) (Page 184) = any setting other than NONE	Totalizers (2.7.3.) (Page 198)	Volume Units (2.6.2.) (Page 186)

By using Multiplier (2.11.4.2.) (Page 221), the relay contacts can be based on a volume other than a multiple of ten.

Parameter	Value	Description
Enable (2.11.4.1.) (Page 220)	Enabled	Enables Flow Sampler Relay
Multiplier (2.11.4.2.) (Page 221)	4310	Click once every 4310 units
Interval (2.11.4.3.) (Page 221)	2	Sets the INTERVAL (in hours) of the relay contact, usually long.
Relay Duration (2.11.4.4.) (Page 221)	0.2	Sets the DURATION (in seconds) of the relay contact, usually short.
Assigned Relay (2.11.4.5.) (Page 221)	Relay 1	Sets relay 1 to be controlled by external sampler.
Relay Logic (2.11.4.6.) (Page 221)	Normally Closed	Use (if necessary) to change the behaviour of the relay assigned to the sampler. Default: Normally Open

During the periods of low flow, the sampler may be idle for lengths of time. Program Interval (2.11.4.3.) (Page 221) time in hours to drive the sampler. The sampler will operate based on the volume of flow or the time interval, whichever comes first.

## 7.11 Open Channel Monitoring (OCM)

An OCM installation is defined one of three ways, based on the Primary Measuring Device (PMD):

### 1. Dimensional

For some common weir and flume types. PMD dimensions (PMD Dimensions (2.15.4.) (Page 239)) are entered directly.

Vessel Type	
BS- 3680 Rectangular Flume (Page 133)	
BS- 3680 Round Nose Horizontal Crest Weir (Page 134)	
BS- 3680 Trapezoidal Flume (Page 135)	
BS- 3680 U-Flume (Page 137)	
BS- 3680 Finite Crest Weir (Page 139)	
BS- 3680 Thin Plate Rectangular Weir (Page 141)	
BS- 3680 Thin Plate V-Notch Weir (Page 143)	
Rectangular Weir Contracted (Page 145)	
Round Pipe (Page 146)	
Palmer Bowlus Flume (Page 147)	
H-Flume (Page 148)	

### 2. Exponential

For most other weir and flume types. PMD exponents provided by the manufacturer are entered. Flow is calculated using the exponent (Flow Exponent (2.15.3.2.) (Page 236)) and the maximum values (Maximum Head (2.15.3.3.) (Page 237) and Maximum Flow at 20 mA (2.15.3.4.) (Page 237) at 20 mA).

Vessel Type	
Standard Weirs (Page 126)	
Parshall Flume (Page 128)	
Leopold Lagco Flume (Page 129)	
Cut Throat Flume (Page 130)	

### 3. Universal

For all other PMDs, the head-to-flow curve can be plotted based on known breakpoints, usually supplied by the PMD manufacturer.

Vessel Type	
Typical flow characterization (Page 150)	
Example flumes (Page 151)	
Example weirs (Page 152)	

### 7.11.1 Method of Flow Calculation

When using the SITRANS LUT400 in a flow application, the Method of Flow Calculation (2.15.3.1.) (Page 235) must be selected. There are two possible methods for calculating flow with the SITRANS LUT400: absolute or ratiometric, and different information must be entered for the device to carry out the calculation. For more details, and an example, see Method of Flow Calculation (Page 306).

### 7.11.2 Common parameters

These common parameters are required for all installations.

Parameter	Sample Value
	Flow
Response rate in Quick Start (Page 59)	MEDIUM
Transducer (2.1.6.) (Page 174)	XRSS-5
Units (2.1.1.) (Page 172)	M
Low Calibration Point (2.2.1.) (Page 176)	1.8
High Calibration Point (2.2.2.) (Page 176)	0.4
Far Range (2.2.5.) (Page 177)	0.8

### 7.11.3 Setting Zero Head

Many PMDs start flowing higher than the traditional empty distance of the application. You can account for the flow in one of two ways:

1. Use Zero Head Offset (2.15.3.5.) (Page 237) to have OCM calculations ignore levels below that value. Possible head = Low Calibration Point (2.2.1.) (Page 176) minus High Calibration Point (2.2.2.) (Page 176).

---

#### Note

Maximum Head (2.15.3.3.) (Page 237) is preset to Low Calibration Point (2.2.1.) (Page 176) minus High Calibration Point (2.2.2.) (Page 176) and is not updated when Zero Head Offset (2.15.3.5.) (Page 237) is used. Make sure you set Maximum Head (2.15.3.3.) (Page 237) to the correct value when using Zero Head Offset (2.15.3.5.) (Page 237). (Refer to PMD supplier documentation for Maximum Head.)

---

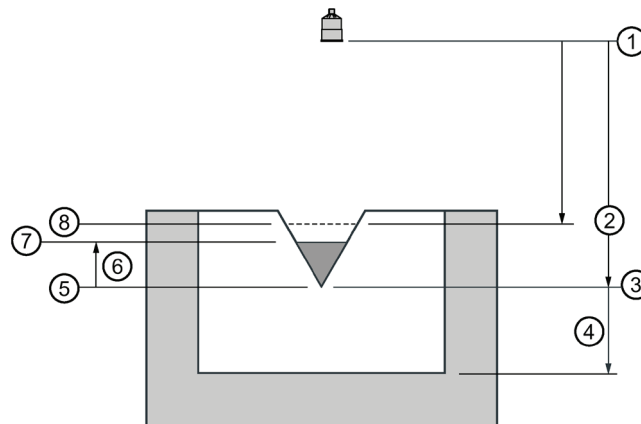

- ① Sensor reference point
- ② High calibration point
- ③ Low calibration point
- ④ Far range
- ⑤ Zero head
- ⑥ Head
- ⑦ Material surface
- ⑧ Maximum head

2. Use Far Range (2.2.5.) (Page 177) where the empty level is set to the bottom of the weir, and above the bottom of the channel. It should be used if the surface monitored can fall past the Low Calibration Point (2.2.1.) (Page 176) level in normal operation without reporting an LOE. The value is added to Low Calibration Point (2.2.1.) (Page 176) and can be greater than the range of the transducer.

The examples on the following pages show both methods.

### 7.11.4 PMDs with Exponential Flow to Head function

For Primary Measuring Devices (PMDs) that measure flow by an exponential equation, use these parameters. Ensure that you use the correct exponent for your PMD; the values below are samples only.

#### 7.11.4.1 Standard Weirs

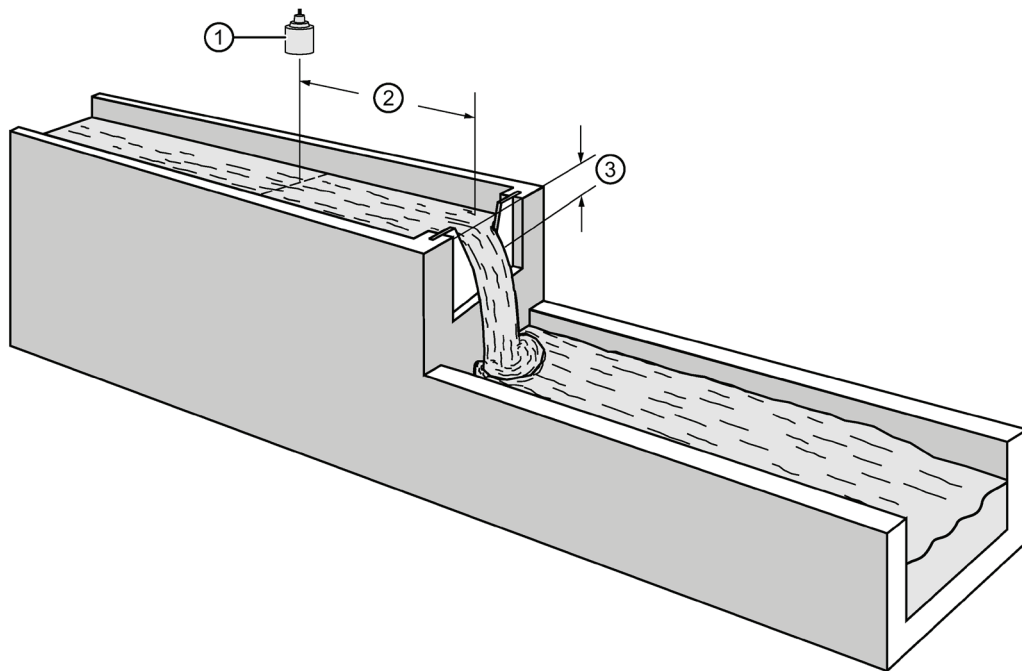

- ① Transducer
- ② 3 to 4 \*  $h_{max}$
- ③  $h$

#### 7.11.4.2 Applicable weir profiles

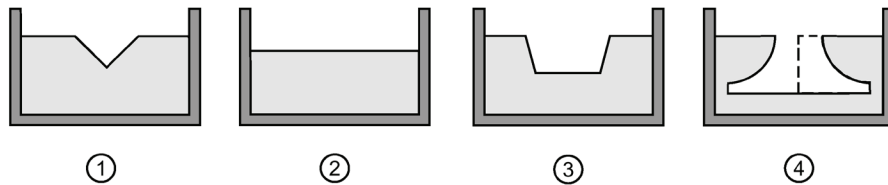

- ① V-notch or triangular
- ② Suppressed rectangular
- ③ Cipolletti or trapezoidal
- ④ Sutro or proportional

Parameter	Value	
Primary Measuring Device (PMD) (2.15.1.) (Page 234)	Exponential Devices	
Flow Exponent (2.15.3.2.) (Page 236)	<b>Weir Type</b>	<b>Value<sup>1</sup></b>
	V-notch	2.50
	Suppressed rectangular	1.50
	Cipolletti or trapezoidal	1.50
	Sutro or proportional	1.00
Maximum Head (2.15.3.3.) (Page 237)		
Maximum Flow at 20 mA (2.15.3.4.) (Page 237)		
Flowrate Units (2.15.3.7.) (Page 238)		
Far Range (2.2.5.) (Page 177)		
K Factor (2.15.4.1.) (Page 240) <sup>2</sup>		

<sup>1)</sup> Values are samples only. Consult weir manufacturer's documentation for correct flow exponent.

<sup>2)</sup> Required for exponential device absolute calculation only.

7.11.4.3 Parshall Flume

**Note**

C = Converging Dimension.

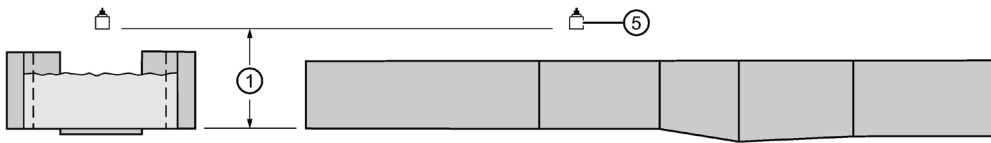
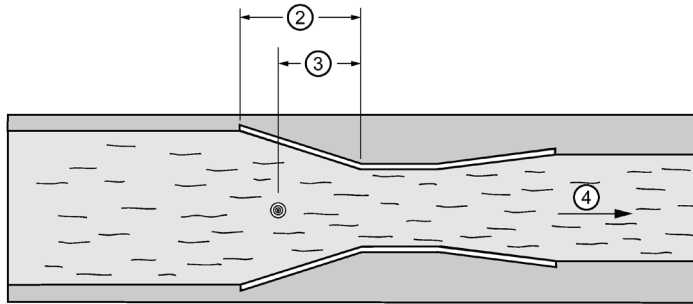

- ① Zero head
- ② Converging dimension C
- ③ 2/3 C
- ④ Flow
- ⑤ Transducer\*

\* The transducer must be above the maximum head by at least the blanking value (see Near Range (2.2.4.) (Page 176)).

**Application Information**

- Sized by throat width
- Set on solid foundation
- For rated flows under free flow conditions, the head is measured at 2/3 the length of the converging section from the beginning of the throat section.

Parameter	Value
Primary Measuring Device (PMD) (2.15.1.) (Page 234)	Exponential Devices
Flow Exponent (2.15.3.2.) (Page 236)	1.522–1.607 <sup>a</sup>
Maximum Head (2.15.3.3.) (Page 237)	
Maximum Flow at 20 mA (2.15.3.4.) (Page 237)	
K Factor (2.15.4.1.) (Page 240) <sup>b</sup>	

<sup>a</sup> Typical Flow Exponent range for Parshall Flume; consult your flume documentation.

<sup>b</sup> Required for exponential device absolute calculation only.



### 7.11.4.4 Leopold Lagco Flume

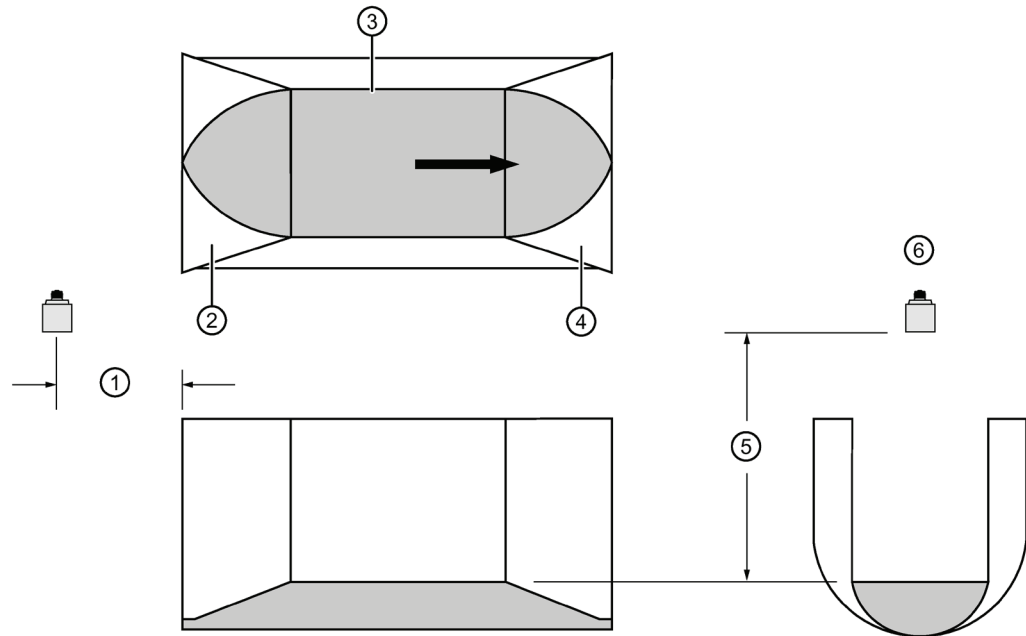

- ① Point of measurement
- ② Converging
- ③ Throat
- ④ Diverging
- ⑤ Zero head
- ⑥ Transducer

\* The transducer must be above the maximum head by at least the blanking value (see Near Range (2.2.4.) (Page 176)).

Parameter	Value
Primary Measuring Device (PMD) (2.15.1.) (Page 234)	Exponential Devices
Flow Exponent (2.15.3.2.) (Page 236)	1.547 <sup>1</sup>
Maximum Head (2.15.3.3.) (Page 237)	
Maximum Flow at 20 mA (2.15.3.4.) (Page 237)	
Zero Head Offset (2.15.3.5.) (Page 237)	
Flowrate Units (2.15.3.7.) (Page 238)	
K Factor (2.15.4.1.) (Page 240) <sup>2</sup>	

<sup>1</sup>) Typical Flow Exponent for Leopold Lagco Flume; consult your flume documentation.

<sup>2</sup>) Required for exponential device absolute calculation only.

7.11 Open Channel Monitoring (OCM)

**Application information**

- Designed to be installed directly into pipelines and manholes
- Leopold Lagco may be classed as a rectangular Palmer-Bowlus flume
- Sized by pipe (sewer) diameter
- For rated flows under free flow conditions, the head is measured at a point upstream referenced to the beginning of the converging section. Refer to the following table:

Flume Size (pipe diameter in inches)	Point of Measurement	
	cm	inches
4-12	2.5	1
15	3.2	1.25
18	4.4	1.75
21	5.1	2
24	6.4	2.5
30	7.6	3
42	8.9	3.5
48	10.2	4
54	11.4	4.5
60	12.7	5
66	14.0	5.5
72	15.2	6

7.11.4.5 Cut Throat Flume

**Plan View**

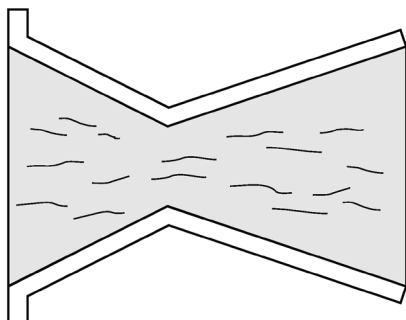

**Application Information**

- Similar to Parshall flume except that the floor is flat bottomed and throat has no virtual length.
- Refer to manufacturer’s specifications for flow equation and point of head measurement.

Parameter	Value
Primary Measuring Device (PMD) (2.15.1.) (Page 234)	Exponential Devices
Flow Exponent (2.15.3.2.) (Page 236)	1.56-2.00 <sup>1</sup>
Maximum Head (2.15.3.3.) (Page 237)	
Maximum Flow at 20 mA (2.15.3.4.) (Page 237)	
Flowrate Units (2.15.3.7.) (Page 238)	
K Factor (2.15.4.1.) (Page 240) <sup>2</sup>	

<sup>1</sup>) Typical Flow Exponent range for Cut Throat Flume; consult your flume documentation.

<sup>2</sup>) Required for exponential device absolute calculation only.

### 7.11.4.6 Khafagi Venturi

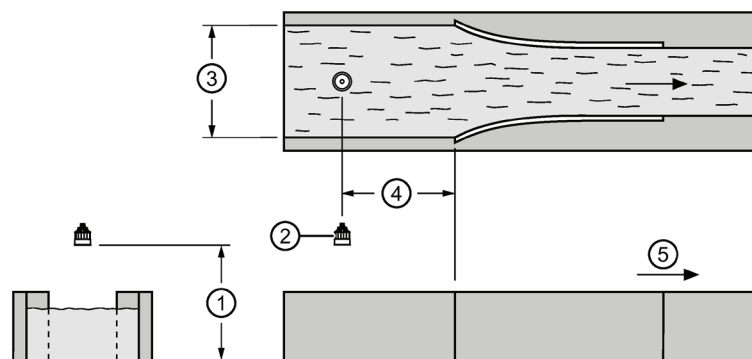

- ① Zero head
- ② Transducer
- ③ Channel width
- ④ 1 x Channel width
- ⑤ Flow

\* The transducer must be above the maximum head by at least the blanking value (see Near Range (2.2.4.) (Page 176)).

#### Application Information

- Similar to Parshall flume except that the floor is flat bottomed and the sidewalls are curved.
- For rated flows under free flow conditions, the head is measured 1 x (channel width) upstream from the beginning of the converging section.

Parameter	Value
Primary Measuring Device (PMD) (2.15.1.) (Page 234)	Exponential Devices
Flow Exponent (2.15.3.2.) (Page 236)	1.55 (Consult your flume documentation.)
Maximum Head (2.15.3.3.) (Page 237)	

7.11 Open Channel Monitoring (OCM)

Parameter	Value
Maximum Flow at 20 mA (2.15.3.4.) (Page 237)	
Flowrate Units (2.15.3.7.) (Page 238)	
K Factor (2.15.4.1.) (Page 240) <sup>1</sup>	

<sup>1</sup>) Required for exponential device absolute calculation only.

**BS- 3680 Rectangular Flume**

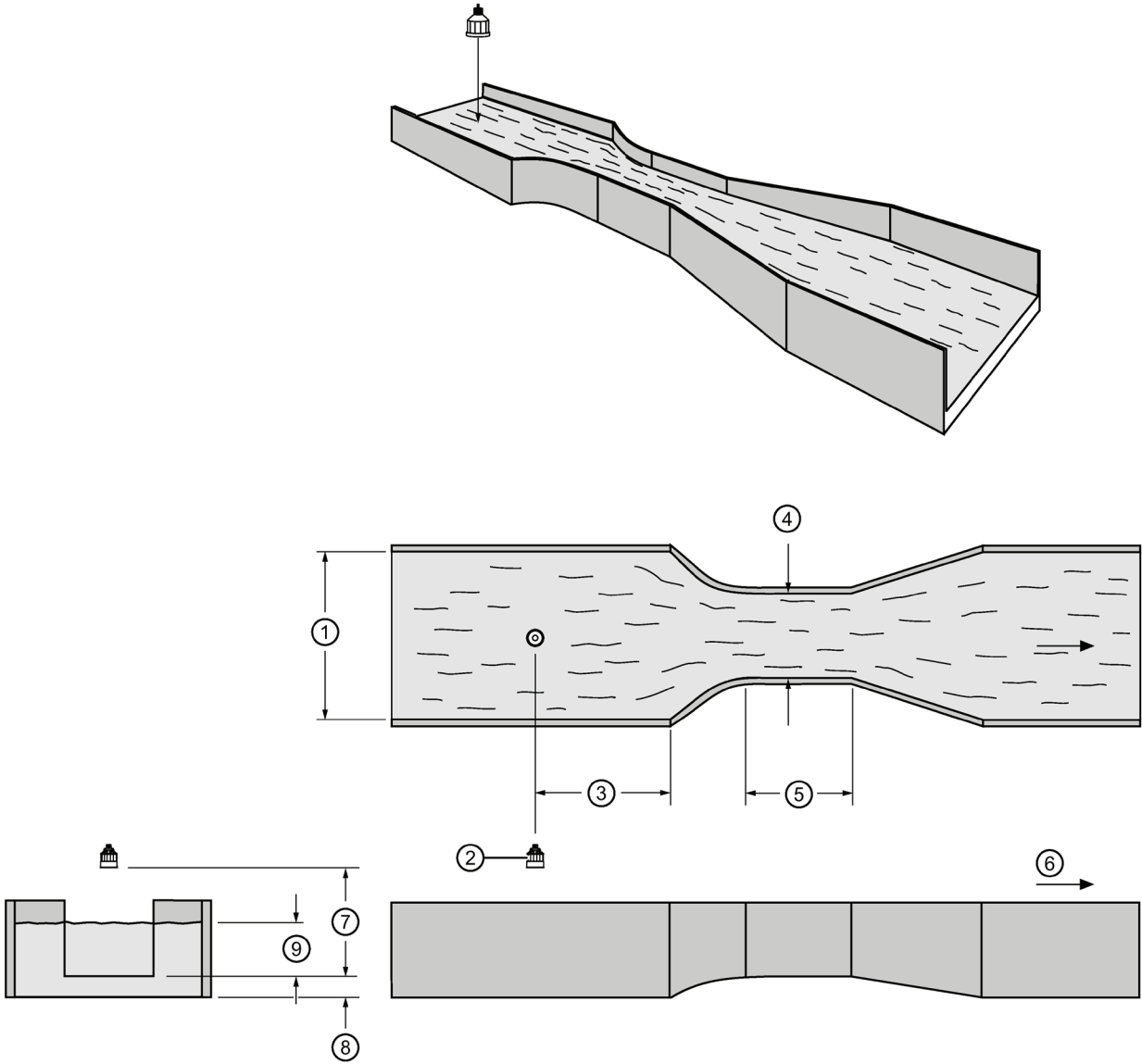

- ① Approach width (B)
- ② Transducer
- ③ 3 to 4 x  $h_{max}$
- ④ Throat width (b)
- ⑤ Throat length (L)
- ⑥ Flow
- ⑦ Zero head
- ⑧ Hump height (p)
- ⑨ Height (h)

\* The transducer must be above the maximum head by at least the blanking value (see Near Range (2.2.4.) (Page 176)).

Parameter	Value
Primary Measuring Device (PMD) (2.15.1.) (Page 234)	BS-3680 Rectangular Flume
PMD Dimensions (2.15.4.) (Page 239)	Approach width (B)
	Throat width (b)
	Hump Height (p)
	Throat length (L)
Zero Head Offset (2.15.3.5.) (Page 237)	
Flowrate Units (2.15.3.7.) (Page 238)	
Method of Flow Calculation (2.15.3.1.) (Page 235)	
Maximum Flow at 20 mA (2.15.3.4.) (Page 237)	

**BS- 3680 Round Nose Horizontal Crest Weir**

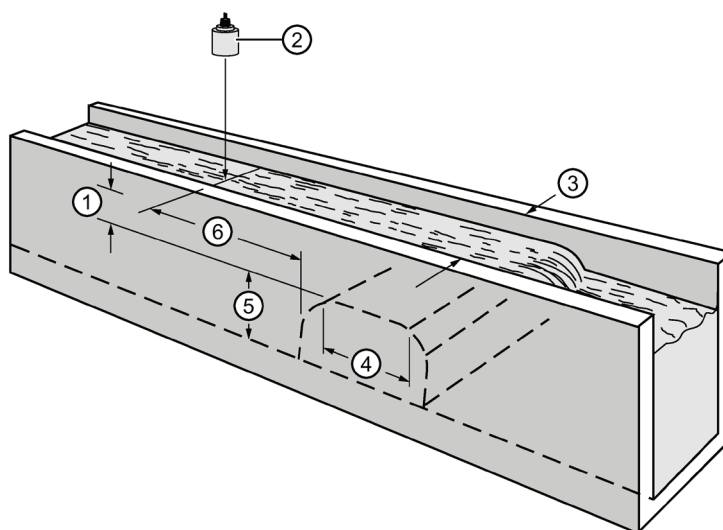

- ① Height (h)
- ② Transducer
- ③ Crest width (b)
- ④ Crest length (L)
- ⑤ Crest height (p)
- ⑥ 3 to 4 x  $h_{max}$

\* The transducer must be above the maximum head by at least the blanking value (see Near Range (2.2.4.) (Page 176)).

Parameter	Value
Primary Measuring Device (PMD) (2.15.1.) (Page 234)	BS-3680 Round Nose Horizontal Crest Weir
PMD Dimensions (2.15.4.) (Page 239)	Crest Width b

Parameter	Value
	Crest Height p
	Crest Length L
Maximum Head (2.15.3.3.) (Page 237)	
Far Range (2.2.5.) (Page 177)	
Flowrate Units (2.15.3.7.) (Page 238)	
Method of Flow Calculation (2.15.3.1.) (Page 235)	
Maximum Flow at 20 mA (2.15.3.4.) (Page 237)	

### BS- 3680 Trapezoidal Flume

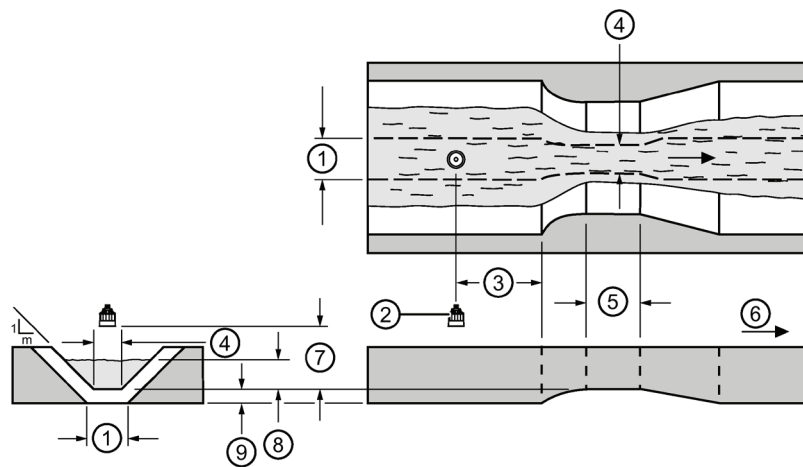

- ① Approach Width (B)
- ② Transducer
- ③ 3 to 4 x  $h_{max}$
- ④ Throat width (b)
- ⑤ Throat length (L)
- ⑥ Flow
- ⑦ Zero head
- ⑧ Height (H)
- ⑨ Hump Height (p)

\* The transducer must be above the maximum head by at least the blanking value (see Near Range (2.2.4.) (Page 176)).

Parameter	Value
Primary Measuring Device (PMD) (2.15.1.) (Page 234)	BS-3680 Trapezoidal Flume
PMD Dimensions (2.15.4.) (Page 239)	Slope m

7.11 Open Channel Monitoring (OCM)

Parameter	Value
	Approach Width B
	Throat Width b
	Hump Height p
	Throat length L
Maximum Head (2.15.3.3.) (Page 237)	
Far Range (2.2.5.) (Page 177)	
Flowrate Units (2.15.3.7.) (Page 238)	
Method of Flow Calculation (2.15.3.1.) (Page 235)	
Maximum Flow at 20 mA (2.15.3.4.) (Page 237)	



BS- 3680 U-Flume

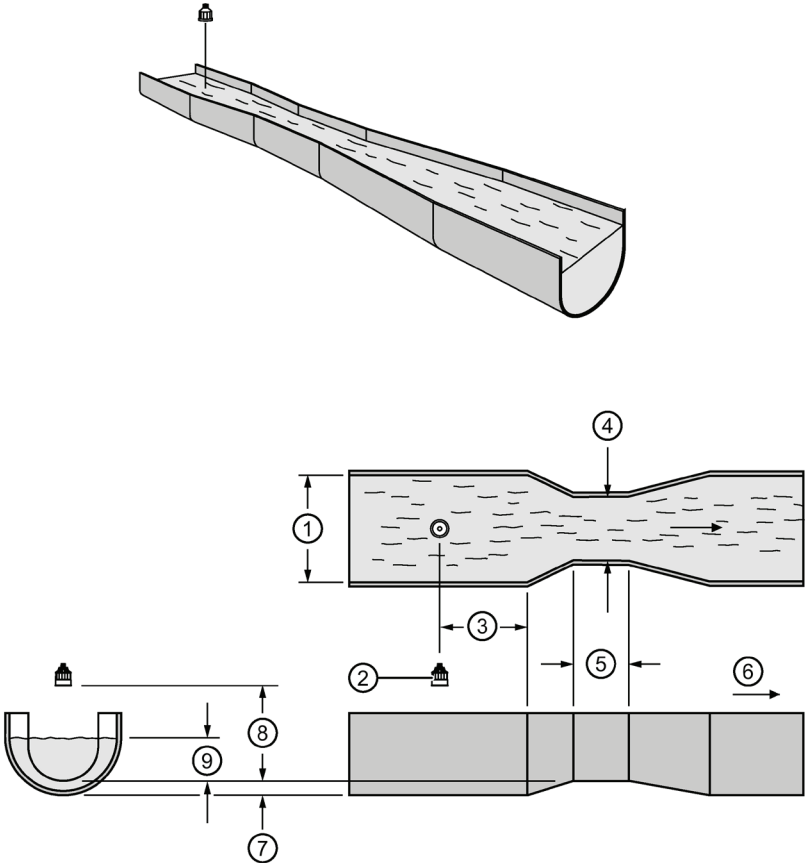

- ① Approach Diameter ( $D_a$ )
- ② Transducer
- ③ 3 to 4 x  $h_{max}$
- ④ Throat Diameter ( $D$ )
- ⑤ Throat Length ( $L$ )
- ⑥ Flow
- ⑦ Hump Height ( $p$ )
- ⑧ Zero head
- ⑨ Height ( $h$ )

\* The transducer must be above the maximum head by at least the blanking value (see Near Range (2.2.4.) (Page 176)).

Parameter	Value
Primary Measuring Device (PMD) (2.15.1.) (Page 234)	BS-3680 U-Flume
PMD Dimensions (2.15.4.) (Page 239)	Approach Diameter $D_a$
	Throat Diameter $D$

Parameter	Value
	Hump Height p
	Throat Length L
Maximum Head (2.15.3.3.) (Page 237)	
Far Range (2.2.5.) (Page 177)	
Flowrate Units (2.15.3.7.) (Page 238)	
Method of Flow Calculation (2.15.3.1.) (Page 235)	
Maximum Flow at 20 mA (2.15.3.4.) (Page 237)	

BS- 3680 Finite Crest Weir

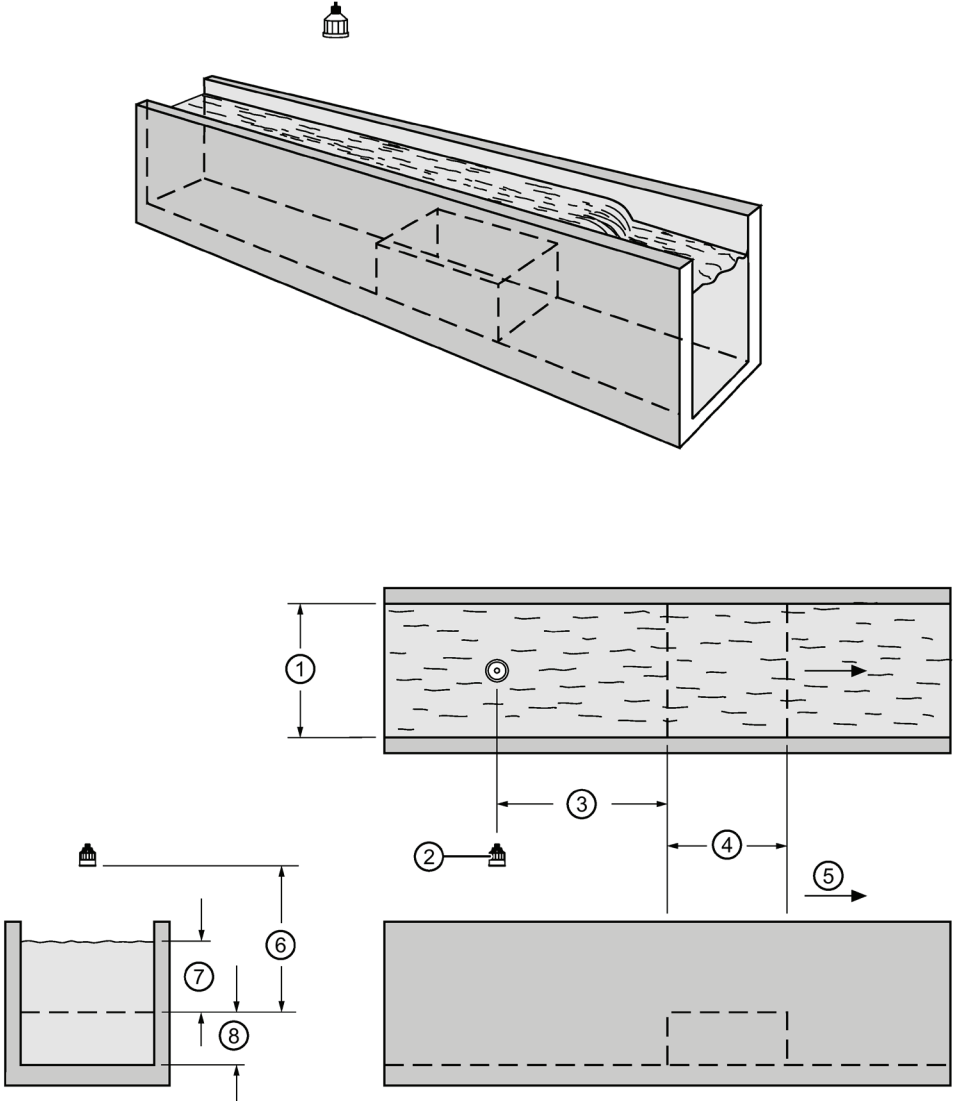

- ① Crest Width (b)
- ② Transducer
- ③ 3 to 4 x  $h_{max}$
- ④ Crest Length (L)
- ⑤ Flow
- ⑥ Zero Head
- ⑦ Height (h)
- ⑧ Crest Height (p)

\* The transducer must be above the maximum head by at least the blanking value (see Near Range (2.2.4.) (Page 176)).

7.11 Open Channel Monitoring (OCM)

Parameter	Value
Primary Measuring Device (PMD) (2.15.1.) (Page 234)	BS-3680 Finite Crest Weir
PMD Dimensions (2.15.4.) (Page 239)	Crest Width b
	Crest Height p
	Crest Length L
Maximum Head (2.15.3.3.) (Page 237)	
Far Range (2.2.5.) (Page 177)	
Flowrate Units (2.15.3.7.) (Page 238)	
Method of Flow Calculation (2.15.3.1.) (Page 235)	
Maximum Flow at 20 mA (2.15.3.4.) (Page 237)	

**BS- 3680 Thin Plate Rectangular Weir**

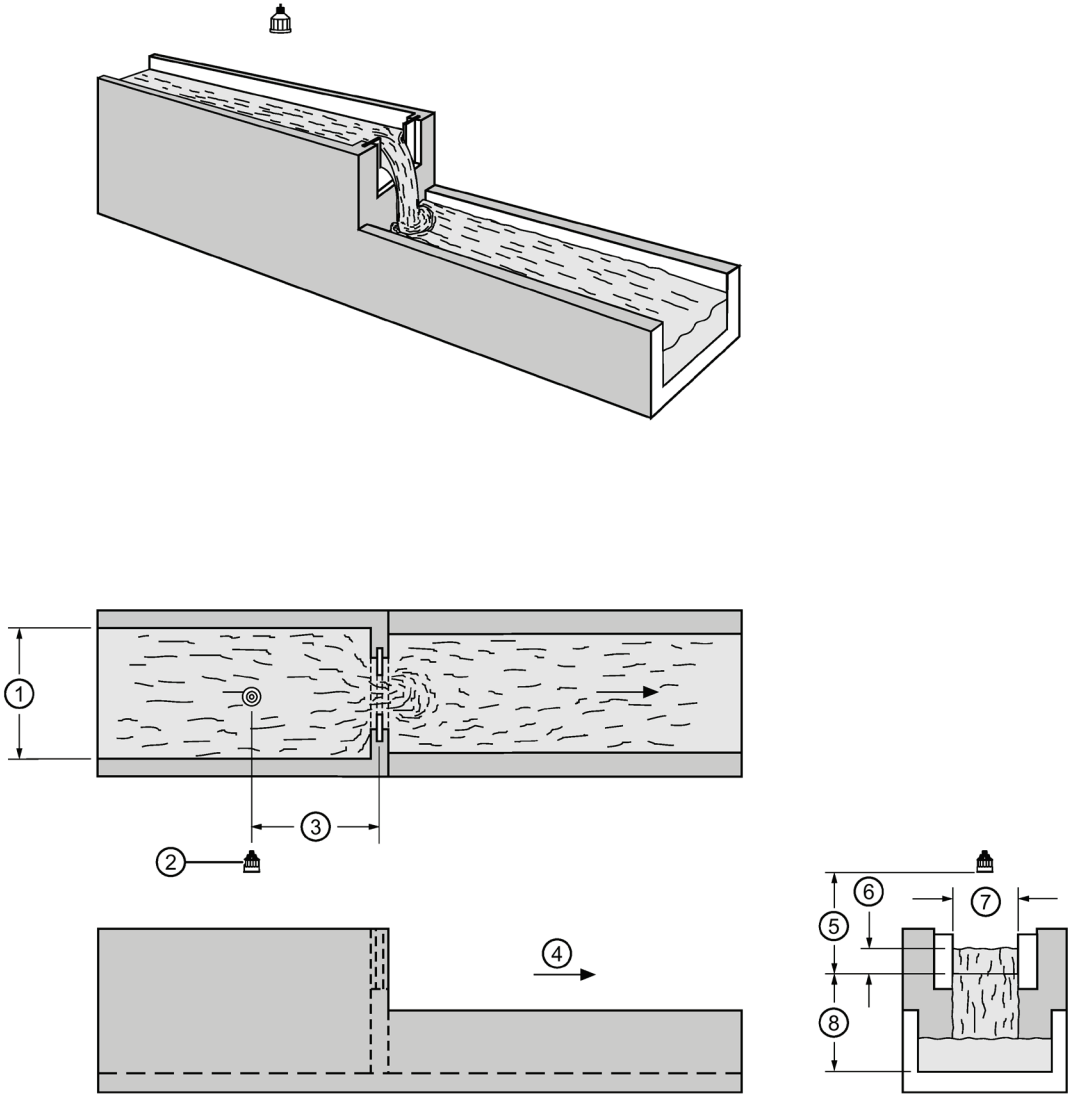

- ① Approach width (B)
- ② Transducer
- ③ 3 to 4 x  $h_{max}$
- ④ Flow
- ⑤ Zero Head
- ⑥ Height (h)
- ⑦ Crest Width (b)
- ⑧ Crest Height (p)

\* The transducer must be above the maximum head by at least the blanking value (see Near Range (2.2.4.) (Page 176)).

7.11 Open Channel Monitoring (OCM)

Parameter	Value
Primary Measuring Device (PMD) (2.15.1.) (Page 234)	BS-3680 Thin Plate Rectangular Weir
PMD Dimensions (2.15.4.) (Page 239)	Crest Width b
	Crest Height p
Maximum Head (2.15.3.3.) (Page 237)	
Far Range (2.2.5.) (Page 177)	
Flowrate Units (2.15.3.7.) (Page 238)	
Method of Flow Calculation (2.15.3.1.) (Page 235)	
Maximum Flow at 20 mA (2.15.3.4.) (Page 237)	

**BS- 3680 Thin Plate V-Notch Weir**

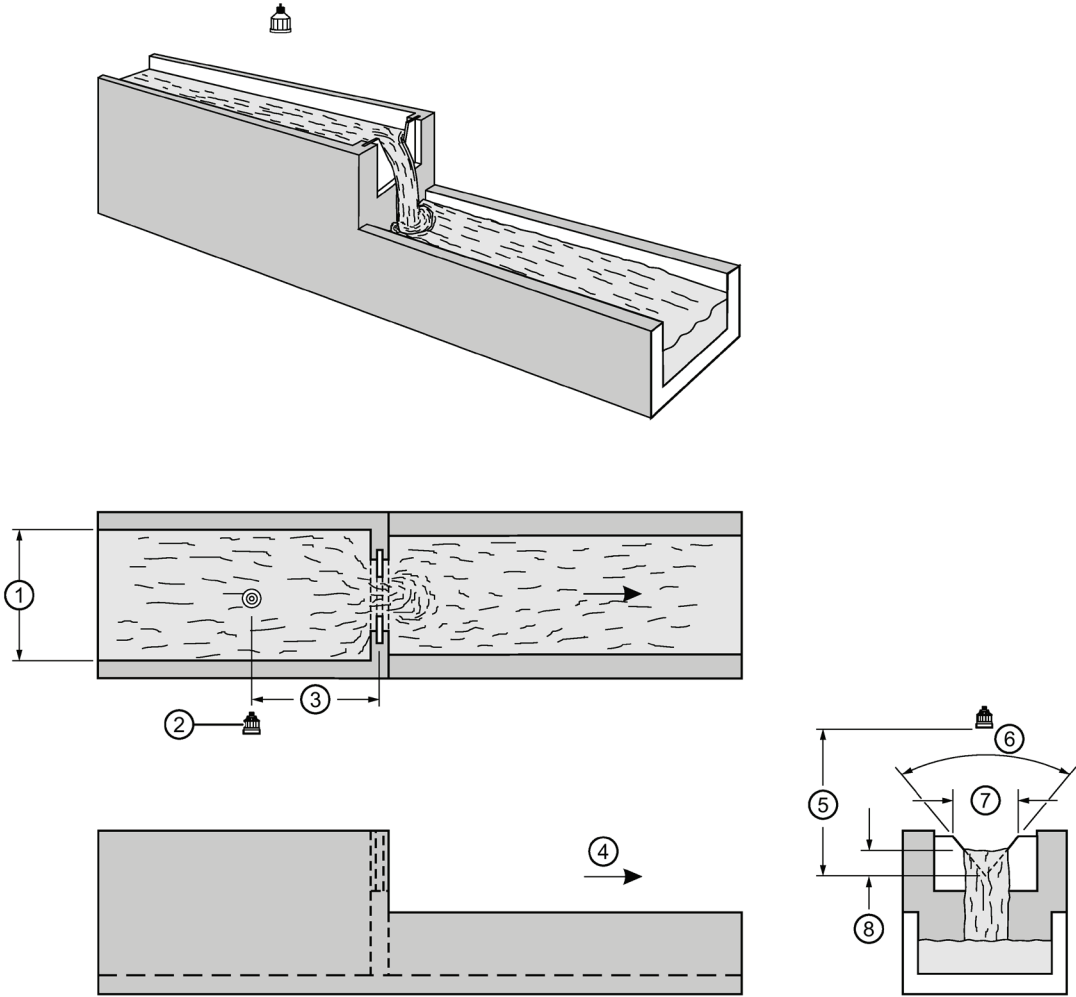

- ① Approach width (B)
- ② Transducer
- ③ 4 to 5 x  $h_{max}$
- ④ Flow
- ⑤ Zero head
- ⑥ Notch angle (a)
- ⑦ Crest width (b)
- ⑧ Height (h)

\* The transducer must be above the maximum head by at least the blanking value (see Near Range (2.2.4.) (Page 176)).

Parameter	Value
Primary Measuring Device (PMD) (2.15.1.) (Page 234)	BS-3680 Thin Plate V-Notch Weir
PMD Dimensions (2.15.4.) (Page 239)	Notch angle (a)
Maximum Head (2.15.3.3.) (Page 237)	

Parameter	Value
Far Range (2.2.5.) (Page 177)	
Flowrate Units (2.15.3.7.) (Page 238)	
Method of Flow Calculation (2.15.3.1.) (Page 235)	
Maximum Flow at 20 mA (2.15.3.4.) (Page 237)	



### Rectangular Weir Contracted

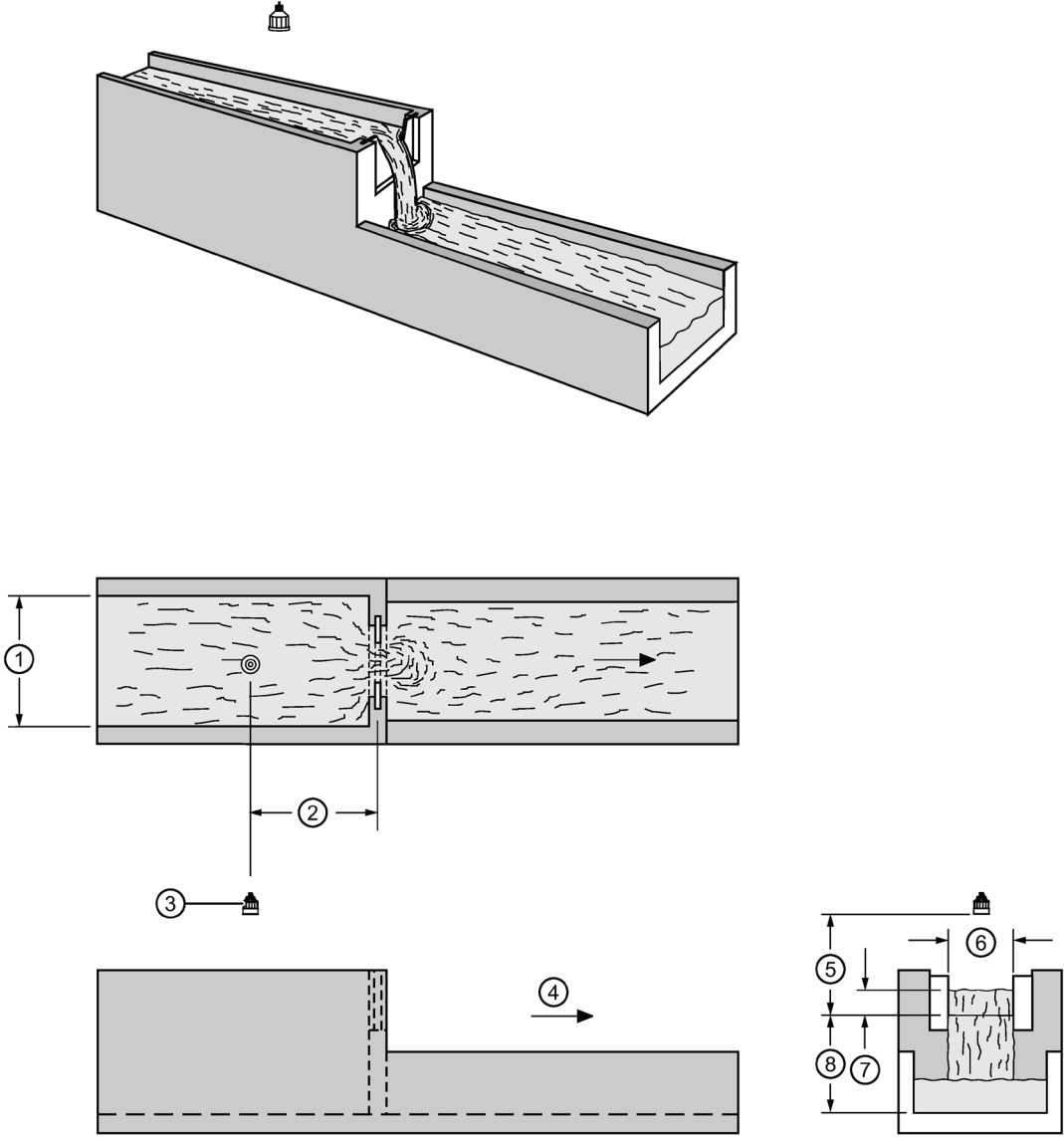

- ① Approach width (B)
- ② 4 to 5 x  $h_{max}$
- ③ Transducer
- ④ Flow
- ⑤ Zero head
- ⑥ Crest width (b)
- ⑦ Height (h)
- ⑧ Crest Height (p)

7.11 Open Channel Monitoring (OCM)

\* The transducer must be above the maximum head by at least the blanking value (see Near Range (2.2.4.) (Page 176)).

Parameter	Value
Primary Measuring Device (PMD) (2.15.1.) (Page 234)	Rectangular Weir Contracted
PMD Dimensions (2.15.4.) (Page 239)	Crest Width b
Maximum Head (2.15.3.3.) (Page 237)	
Far Range (2.2.5.) (Page 177)	
Flowrate Units (2.15.3.7.) (Page 238)	
Method of Flow Calculation (2.15.3.1.) (Page 235)	
Maximum Flow at 20 mA (2.15.3.4.) (Page 237)	

Round Pipe

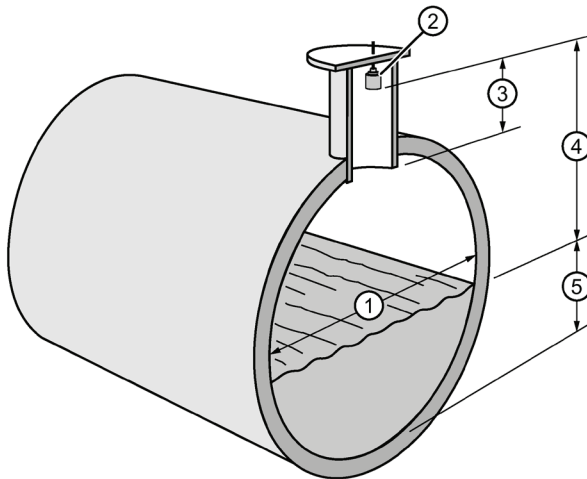

- ① Pipe Inside Diameter (D)
- ② Transducer
- ③ This dimension should be at least 15 cm (6") shorter than the blanking value (see Near Range (2.2.4.) (Page 176)).
- ④ The transducer must be above the maximum head by at least the blanking value.
- ⑤ Height (h)

Parameter	Value
Primary Measuring Device (PMD) (2.15.1.) (Page 234)	Round Pipe
PMD Dimensions (2.15.4.) (Page 239)	Pipe Inside Diameter D
	Slope (fall/run) s
	Roughness Coefficient n
Maximum Head (2.15.3.3.) (Page 237)	
Far Range (2.2.5.) (Page 177)	
Flowrate Units (2.15.3.7.) (Page 238)	
Method of Flow Calculation (2.15.3.1.) (Page 235)	
Maximum Flow at 20 mA (2.15.3.4.) (Page 237)	

## Palmer Bowlus Flume

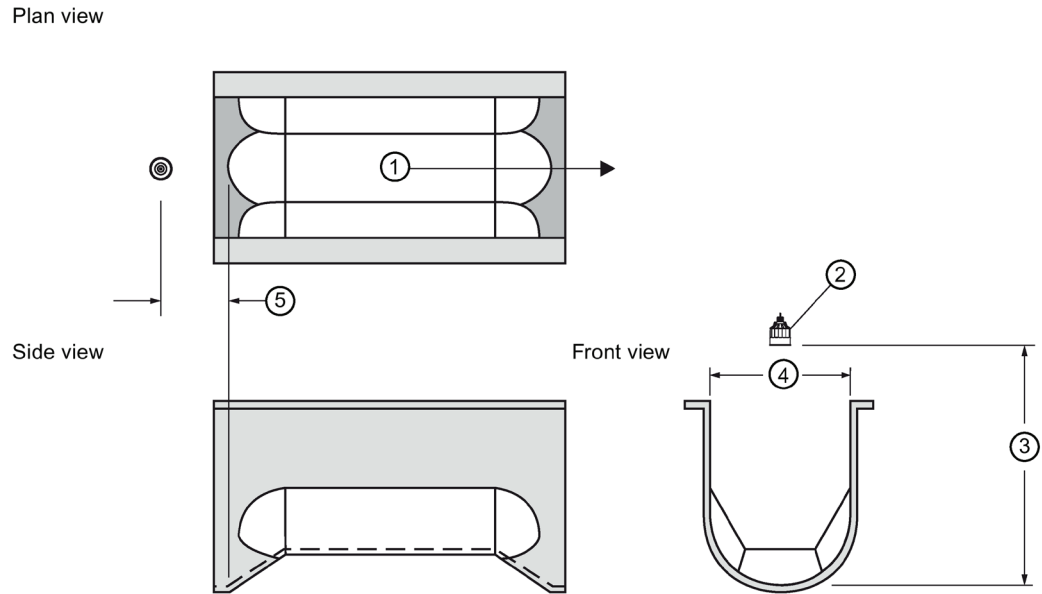

- ① Flow
- ② Transducer  
The transducer must be above the maximum head by at least the blanking value. See Near Range (2.2.4.) (Page 176).
- ③ Zero head
- ④ D
- ⑤  $D/2$ , point of measurement for rated flows under free flow conditions.

Parameter	Value
Primary Measuring Device (PMD) (2.15.1.) (Page 234)	Palmer Bowlus Flume
PMD Dimensions (2.15.4.) (Page 239)	Maximum Flume width $h_{max}$
Maximum Head (2.15.3.3.) (Page 237)	
Maximum Flow at 20 mA (2.15.3.4.) (Page 237)	
Zero Head Offset (2.15.3.5.) (Page 237)	
Flowrate Units (2.15.3.7.) (Page 238)	
Method of Flow Calculation (2.15.3.1.) (Page 235)	Ratiometric

### Note

Palmer Bowlus Flume can only be set up using ratiometric calculations.

### Application information

- Sized by pipe diameter D.
- Flume relief is trapezoidal.

7.11 Open Channel Monitoring (OCM)

- Designed to install directly into pipelines and manholes.
- Head is referenced to bottom of the throat, not bottom of the pipe.
- For rated flows under free flow conditions, the head is measured at a distance of D/2 upstream from the beginning of the converging section.

H-Flume

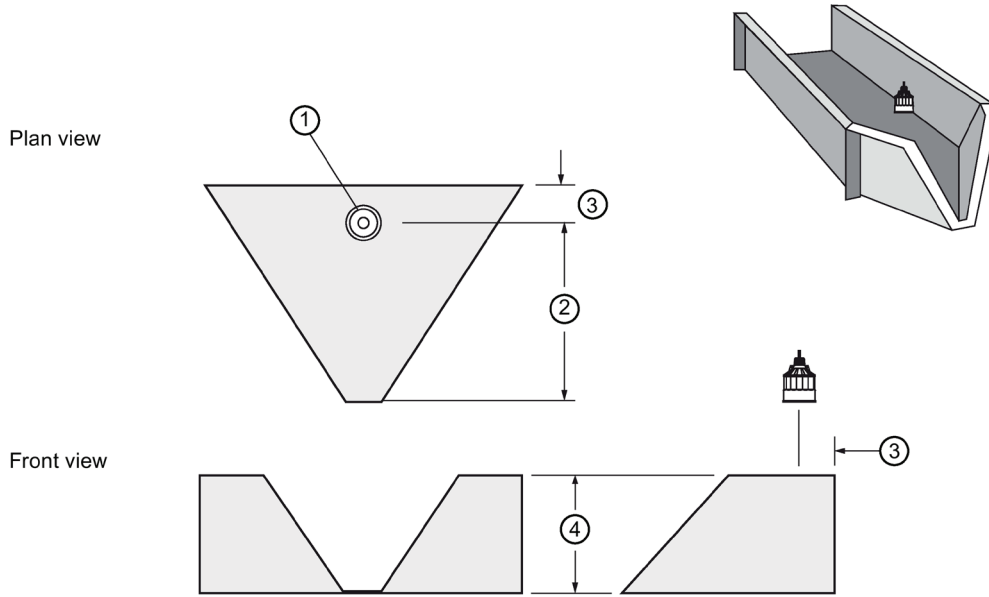

- ① Transducer  
The transducer must be above the maximum head by at least the blanking value (see Near Range (2.2.4.) (Page 176)).
- ② Flow
- ③ Point of measurement
- ④ Flume height D

Parameter	Value
Primary Measuring Device (PMD) (2.15.1.) (Page 234)	H-Flume
PMD Dimensions (2.15.4.) (Page 239)	Flume height (D)
Maximum Head (2.15.3.3.) (Page 237)	
Maximum Flow at 20 mA (2.15.3.4.) (Page 237)	
Flowrate Units (2.15.3.7.) (Page 238)	
Method of Flow Calculation (2.15.3.1.) (Page 235)	Ratiometric

**Note**

H-Flume can only be setup using ratiometric calculations.

- Sized by maximum depth of flume.
- Approach is preferably rectangular, matching width and depth for distance 3 to 5 times the depth of the flume.
- May be installed in channels under partial submergence (ratio of downstream level to head). Typical errors are:
  - 1% @ 30% submergence
  - 3% @ 50% submergence
- For rated flows under free flow conditions, the head is measured at a point downstream from the flume entrance. Refer to the following table.

Flume Size (Diameter in feet)	Point of Measurement	
	cm	inches
0.5	5	1.75
0.75	7	2.75
1.0	9	3.75
1.5	14	5.5
2.0	18	7.25
2.5	23	9
3.0	28	10.75
4.5	41	16.25

- H-flumes come with a flat or sloping floor. The same flow table can be used because error is less than 1%.

#### 7.11.4.7 Universal calculation support

When the primary measuring device (PMD) doesn't fit one of the standard types, it can be programmed using a universal characterization. When Universal is selected as the PMD type [Primary Measuring Device (PMD) (2.15.1.) (Page 234)], then both head and flow breakpoints (Universal Head versus Flow (2.15.5.) (Page 241)) must be entered to define the flow.

SITRANS LUT400 supports Universal curved (cubic spline) flow calculation shown in the following chart. (The Method of Flow Calculation (2.15.3.1.) (Page 235) for universal support can be Ratiometric or Absolute. Refer to your PMD manufacturer's documentation.)

7.11.4.8 Typical flow characterization

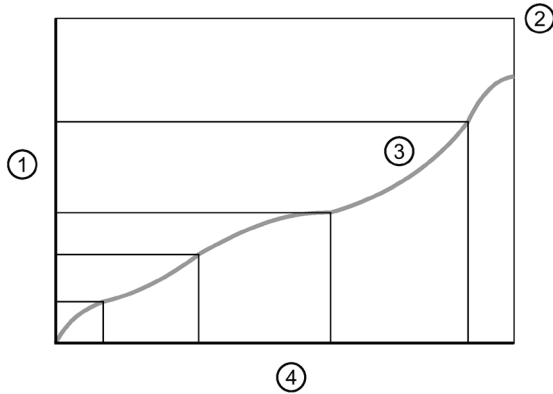

- ① Flow Breakpoints
- ② Maximums (Max. Head, Max. Flow)
- ③ Curved
- ④ Head Breakpoints

Characterization is achieved by entering the head and corresponding flow breakpoints, either from empirical measurement or from the manufacturer's specification. Increasing the number of defined breakpoints will increase the accuracy of the flow measurement.

Breakpoints should be concentrated in areas exhibiting the higher degrees of non linear flow. A maximum of 32 breakpoints can be defined, with a minimum of four required. The curve's end point is always specified by the parameters Maximum Head (2.15.3.3.) (Page 237) and Maximum Flow at 20 mA (2.15.3.4.) (Page 237). These two parameter values are in addition to the 32 breakpoints available for definition.

Use as many breakpoints as required by the complexity of your PMD.

See Volume (Page 95) for more information and parameter Universal Head versus Flow (2.15.5.) (Page 241) for characterization.

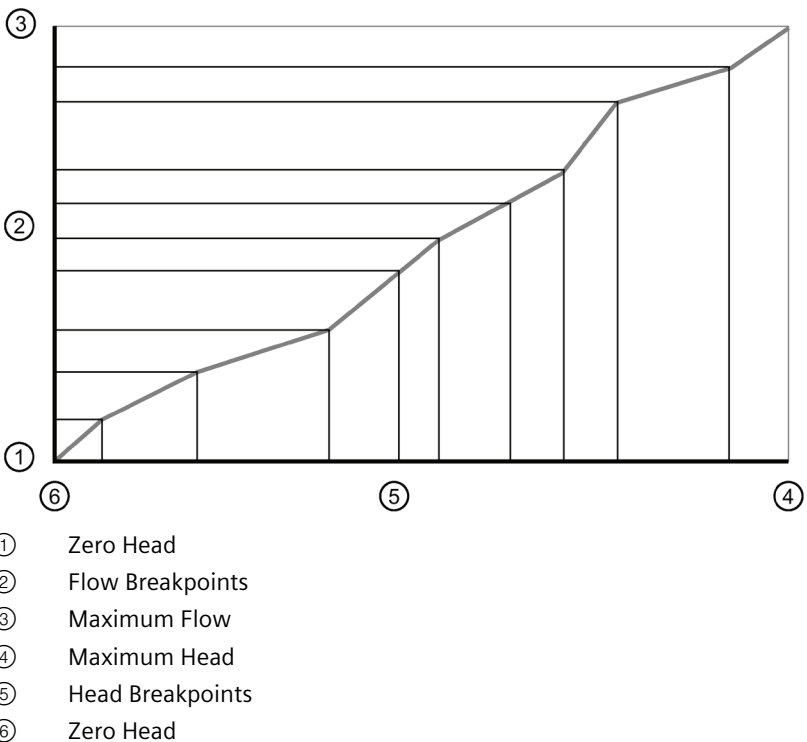

**7.11.4.9 Example flumes**

These example flumes would both require a universal calculation.

**Trapezoidal**

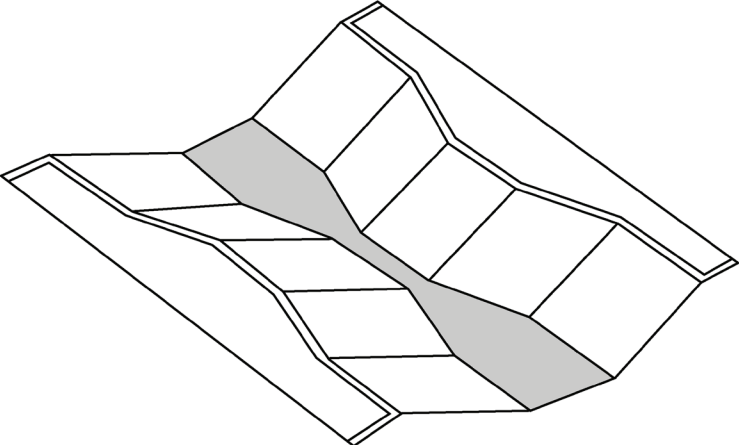

Dual Range (nested) Parshall

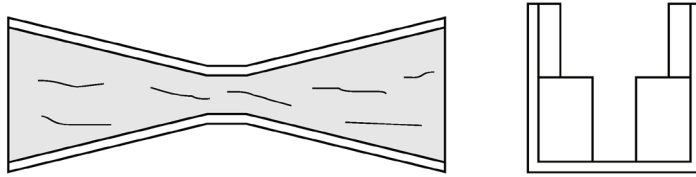

7.11.4.10 Example weirs

These weirs could require universal calculation.

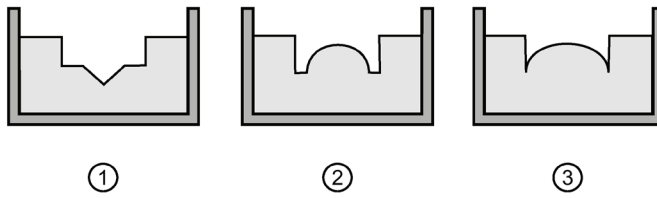

- ① Compound
- ② Poebing
- ③ Approximate exponential



## 7.12 Trends

To view trend lines, navigate to Maintenance and Diagnostics (3.) (Page 244) > Diagnostics (3.2.) (Page 246) > Trend (3.2.2.) (Page 246). The PV (in percentage) is logged at five minute intervals and trend displays up to 3000 data points since last power up.

- Press **RIGHT arrow** ► to request a trend.

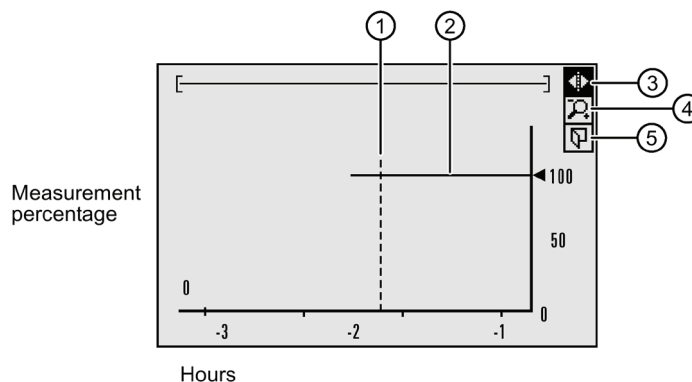

- ① Cross-hairs
- ② Current measurement
- ③ Pan left/right icon
- ④ Zoom icon
- ⑤ Exit icon

- Use **UP ▲** or **DOWN arrow ▼** to scroll to an icon. When an icon is highlighted, that feature becomes active.
- To move the cross-hair, press **RIGHT arrow** ► to increase the value, **LEFT arrow** ◀ to decrease.
- To Zoom into an area, position the cross-hairs at the center of that area, select Zoom icon, and press **RIGHT arrow** ► . Press **LEFT arrow** ◀ to Zoom out.
- To return to the previous menu, select **Exit** icon then press **RIGHT arrow** ► .

---

### Note

- When a fail-safe condition has occurred, it will appear as a gap in the Trend line.
  - Trend view will not timeout. This view will display on LUI until the exit icon is selected.
-

## 7.13 Data logging

The SITRANS LUT400 provides an extensive logging feature which can be viewed on the local display or downloaded to a PC through USB using the Web Browser tool.

Enable data logging for a Process Value, an Alarm, or for Flow (see Data Logging (2.10.) (Page 214)).

For flow, the logging rate can be fixed or variable. The latter being useful in conserving logging space. The condition for variable logging is determined when selecting the logging rate.

Variable logging rate conditions are categorized as: percent change of flow per minute, percent change of maximum flow or percent change of maximum head. Logging occurs at the normal (slower) rate while the condition is less than the setpoint (Rapid Flow Log Setpoint (2.10.4.6.) (Page 216)). If the condition exceeds the rapid flow log setpoint, the rapid rate of logging takes effect until the condition falls below the standard flow log setpoint (Standard Flow Log Setpoint (2.10.4.4.) (Page 216)).

The setpoints represent the absolute value of the rate of change; that is, for either increasing or decreasing flowrate. The SITRANS LUT400 does not recognize negative entries for standard or rapid flow log setpoints.

Flow data is logged in flowrate units (with full resolution of flow measurement value) from 0 to 110% of maximum flow. Flows above 110% are logged at the 110% value (in flowrate units). Truncation of flows to 110% does not apply to daily totalization.

### 7.13.1 Viewing the Data Log

To view the data log, navigate to Maintenance and Diagnostics (3.) (Page 244) > Diagnostics (3.2.) (Page 246) > View Logs (3.2.6.) (Page 247) and select the desired log; Alarms, OCM, PV, or Daily Totals.

The logs can be examined locally via LUI or uploaded to a PC via USB using the Web Browser tool.

LUI logs are viewed by choosing the desired log (Alarm, OCM, Daily Totals, or Primary Variable PV) in 3.2.6.x, and then scroll through the entries using the 'up' and 'down' arrow keys. The most-recent log entry is the initial display. Pressing the 'up' arrow will scroll back in time showing the previous entries.

#### Log Capacity vs. Rates

Rate	Capacity
1 min.	14 days
5	2 months
15	7 months
30	14 months
60	2.4 years
24 hr	50 years

For example:

rate = 15/5, capacity = 3.5 months max/1 month min

When using the Web Browser tool to upload logs, individual log files are stored on the PC in the universal CSV (comma-separated-value) format for ease when importing to other programs, such as spreadsheets or other data-analysis packages. For a list of field names, see Data Logging (Page 307).

To clear entries when memory is full, browse to Delete Logs (2.10.5.) (Page 216) and select Yes to permanently delete all logs.

## 7.14 Simulation

The SITRANS LUT400 supports simulation from the LUI. Level and discrete inputs can be simulated, separately or concurrently.

### Level Simulation

In level simulation, the LCD reacts to the simulated level changes, and activates relays based on the setpoints programmed. The material level can be set to continuously sweep through the measurement range, from Low Calibration Point to High Calibration Point and back again (using Ramp (3.4.1.3.) (Page 263), Ramp Rate (3.4.1.4.) (Page 263)), or the material level can be held at a specific value (using Level Value (3.4.1.2.) (Page 263)).

### Discrete Input Simulation

When discrete inputs are simulated, the DI icon on the LCD will show the simulated states of the discrete inputs. Any programming that uses the discrete inputs, such as the backup level override, will use the simulated values.

In simulation mode, some of the LUT400's configured functionality will respond to the simulated value, including:

- **Readings that are based on Level** - The LUT400 supports simulation of Level values only. Other simulated values cannot be entered, however, these values will be calculated correctly when Level is simulated. Space, Distance, Volume, Flow, and Head will be calculated [see Sensor Mode (2.1.2.) (Page 173)].
- **The milliamp output** - The current loop output will also track the corresponding reading (Level, Space, Distance, Volume, Flow, or Head depending on which of these it is configured to track). [See Current Output (2.5.) (Page 180)]
- **Alarms** - Any alarms that have been configured, including any relays configured for alarms, will activate based on the simulated value. [See Alarms (2.8.) (Page 200).]
- **Relays configured for pumps** - If the device is configured for a pump application then the corresponding relay indicators on the LCD will also show when the pumps would activate. By default the relay contacts themselves will not activate in simulation mode, but this behaviour can be changed if desired (see Pump relay behaviour during simulation (Page 156)).
- **Logging** - Log files will reflect the simulated values. This includes logging simulated high-flow/low-flow conditions, and any alarms.

The following functions will not respond to the simulated value when in simulation mode:

- **Fault Conditions** - The LUT400 will never enter the Fail-safe state when in simulation mode. For further details see Fail-safe and Simulation (Page 157).
- **Backup Level Override** - If a Backup Level Override switch is configured and it lies within the simulated Level range, it will not be simulated. To simulate a Backup Level Override, simulate the discrete input. See Simulating Discrete Inputs (Page 158).
- **Totalizing of OCM Flow** - Totalizing of flow (OCM applications) does not occur during simulation. The OCM Daily Totalizer (2.16.1.) (Page 242) and Running Totalizer (2.16.2.) (Page 242) will not increase in value during simulation.
- **Totalizing of Pumped Volume** - Totalizing of pumped volume does not occur during simulation if Pump Activations (3.4.3.) (Page 264) is set to Disabled. If pumps are set to run during simulation, the material pumped will be totalized (Running Totalizer (2.7.3.1.) (Page 198)).
- **External Sampler** - The external sampler, if configured, will click at its timeout interval when in simulation mode (see Interval (2.11.4.3.) (Page 221)).

### 7.14.1 Pump relay behaviour during simulation

The Pump Activations (3.4.3.) (Page 264) parameter allows you to choose how the physical relays that are assigned to pumps will behave when in simulation mode.

This parameter has two possible values:

**Disabled:** Pump relays are not activated in simulation (default value).

**Enabled:** Pump relays are activated in simulation.

If Pump Activations (3.4.3.) (Page 264) is **Disabled**, only the LCD indicators are affected (the corresponding relay icons will turn ON, but the relays will not energize). If Pump Activations (3.4.3.) (Page 264) is **Enabled**, the relay icons will turn ON, and the relays will energize.

 <b>WARNING</b>
--

Select <b>Enabled</b> only when there is no possibility of the pumps being damaged during simulation, or if the pumps have been locally disabled through some other means.
--

---

#### Note

- If the pump relays are configured to physically activate in simulation mode, then any time activated will be recorded in the pump Run Time parameter (see Pump Records (3.2.7.) (Page 248)).
  - If a pump start delay has been programmed for the device (Delay Between Starts (2.7.2.4.1.) (Page 198)), it will be respected in Simulation mode.
-

### 7.14.2 Fail-safe and Simulation

When simulating Level or Discrete Inputs, the LUT400 will never enter the Fail-safe state. Faults that would normally cause a fail-safe condition (such as a broken cable or LOE) may still occur, but a fail-safe condition will not be reported on the device during simulation.

---

#### Note

As fail-safe will not be reported during simulation, a bench simulation of the LUT400 can be run without a transducer connected.

---

### 7.14.3 HART status

When using HART communications via software tools such as PDM, AMS, FDT, and FC375/475, the Level value and the readings derived from level will display simulated values (when level or discrete input simulation is enabled on LUI). (See *Process Variables* within PDM, AMS, FDT, and FC375/475.) Device status conditions within each tool will also indicate that the device is in simulation mode (see Diagnostics (3.2.) (Page 246)).

### 7.14.4 Simulation process

Simulation is an iterative process whereby parameters are adjusted and corresponding results are viewed in Measurement Mode. Level and Discrete Inputs can be simulated separately, or concurrently. When either simulation is enabled, the LCD displays *Simulation Enabled* in the text area for status messages (see Measurement mode display: Normal operation (Page 52)).

---

#### Note

Simulation Enabled status will display on LCD even if other faults are present.

---

To stop simulation at any time, set the parameter for the function being simulated (Level Simulation Enable (3.4.1.1.) (Page 263), Discrete Input 1 (3.4.2.1.) (Page 263), Discrete Input 2 (3.4.2.2.) (Page 264)) to **Disabled**.

In general, to run a simulation:

1. Select the function to be simulated: Level or Discrete Input (can be simulated concurrently).
2. Set simulation parameters if performing a Level simulation.
3. Decide if pumps will be active during simulation (see Pump relay behaviour during simulation (Page 156)).
4. Start simulation.

#### 7.14.4.1 Simulating a fixed level

1. Set the desired fixed level value in Level Value (3.4.1.2.) (Page 263).
2. Set Ramp (3.4.1.3.) (Page 263) to **Disabled**.
3. **Enable** Pump Activations (3.4.3.) (Page 264) if desired (see Pump relay behaviour during simulation (Page 156)).
4. Set Level Simulation Enable (3.4.1.1.) (Page 263) Enable to **Enabled** to start level simulation.

Set Level Simulation Enable (3.4.1.1.) (Page 263) Enable to **Disabled** when you wish to stop level simulation.

#### 7.14.4.2 Simulating a changing level

1. Set the desired starting level value in Level Value (3.4.1.2.) (Page 263).
2. Set Ramp (3.4.1.3.) (Page 263) to Enabled.
3. Set Ramp Rate (3.4.1.4.) (Page 263) to the desired speed, For example: **Medium**.
4. **Enable** Pump Activations (3.4.3.) (Page 264) if desired (see Pump relay behaviour during simulation (Page 156)).
5. Set Level Simulation Enable (3.4.1.1.) (Page 263) to **Enabled** to start level simulation.

The simulated level will initially begin ramping up from Level Value (3.4.1.2.) (Page 263) (increasing level). When the level rises to 100% or falls to 0%, it reverses direction at the same rate.

Set Level Simulation Enable (3.4.1.1.) (Page 263) to **Disabled** when you wish to stop level simulation.

#### 7.14.4.3 Simulating Discrete Inputs

1. Enable Pump Activations (3.4.3.) (Page 264) if desired (see Pump relay behaviour during simulation (Page 156)).
2. Set the discrete input to be simulated (Discrete Input 1 (3.4.2.1.) (Page 263), Discrete Input 2 (3.4.2.2.) (Page 264) or both) to one of the following:
  - **ON**: the discrete input is simulated to be on
  - **OFF**: the discrete input is simulated to be off.

Set parameter(s) for DI to be simulated (Discrete Input 1 (3.4.2.1.) (Page 263) and/or Discrete Input 2 (3.4.2.2.) (Page 264)) to Disabled if you do not wish to simulate a discrete input, or to stop DI simulation that is currently running.

#### 7.14.4.4 Simulation timeout

Simulation will automatically be disabled and the LUT400 will return to normal measurement and control ten minutes after changing (editing) any simulation parameter (except Level Value (3.4.1.2.) (Page 263)). When the timeout occurs, parameters used to enable simulation (Level Simulation Enable (3.4.1.1.) (Page 263), Discrete Input 1 (3.4.2.1.) (Page 263), Discrete Input 2 (3.4.2.2.) (Page 264)), as well as Pump Activations (3.4.3.) (Page 264) will switch to **Disabled**, and the message **Simulation Enabled** will no longer display on the LCD. (Device status conditions will also reset in PDM, AMS, FDT, and FC375/475.)

#### 7.14.5 Application test

You can test the application by varying the actual material level (the preferred test method), or by simulating level changes.

If you are testing the application via simulation mode, decide if control devices, such as pumps, are to be operational during simulation by setting the Pump Activations (3.4.3.) (Page 264) parameter (see Pump relay behaviour during simulation (Page 156)).

#### WARNING

Only enable Pump Activations (3.4.3.) (Page 264) when there is no possibility of the pumps being damaged during simulation, or if the pumps have been locally disabled through some other means.

While the level is being cycled, check the results of the discrete inputs either by closing the circuit externally (preferred), or by setting DI simulation parameter to force the input **ON** or **OFF**. Try all possible combinations to thoroughly test the setup. When simulating a changing level, run a complete cycle (from Low Calibration Point to High Calibration Point and back again) to verify that the relays operate as expected.

Monitor system performance carefully, under all anticipated operating conditions.

1. When the LUT400 performs exactly as required, programming is complete.
2. If alternate reading units, fail-safe action, or relay operation is desired, update the parameters for the new functionality.
3. If you experience problems with system performance, see Diagnosing and Troubleshooting (Page 271).

If you cannot observe all possible operating conditions by varying the material level, use Simulation process (Page 157) to verify programming.

Retest the system each time you adjust any control parameters.

## 7.15 SITRANS LUT400 Communication Systems

The SITRANS LUT400 is an integrated level controller capable of communicating process information to a Supervisory Control and Data Acquisition (SCADA) system, through a HART modem.

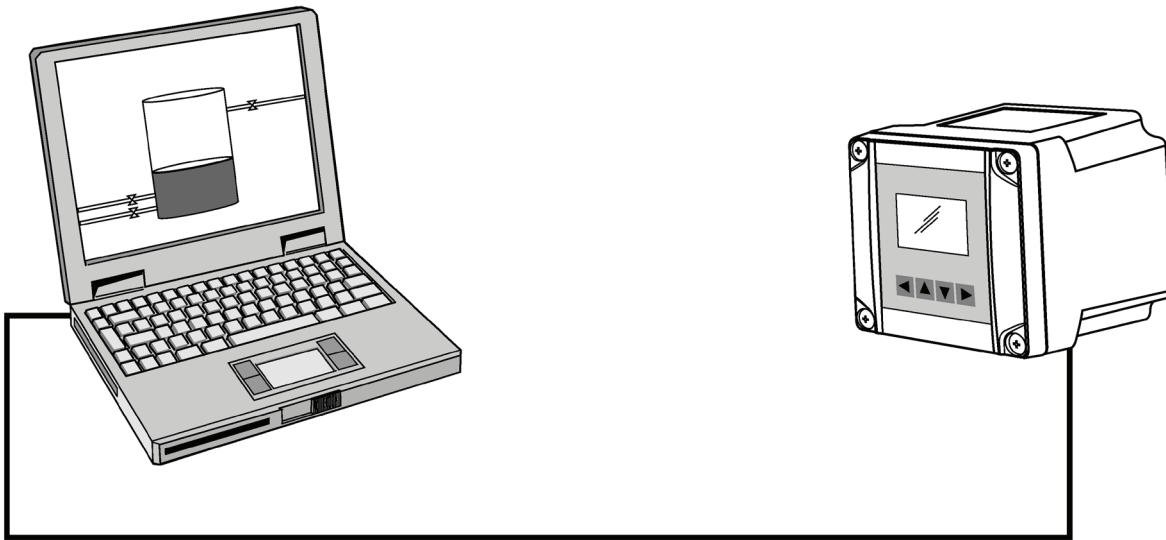

Figure 7-1 Communication via HART modem to SITRANS LUT400

### 7.15.1 LUT400 Communications (HART)

Highway Addressable Remote Transducer, HART, is an industrial protocol that is superimposed on the 4-20 mA signal. It is an open standard, and full details about HART can be obtained from the HART Communication Foundation at <https://fieldcommgroup.org/> (<https://fieldcommgroup.org/>).

SITRANS LUT400 can be configured over the HART network using the HART Communicator 375/475 by Emerson (see Operation via Field Communicator 375/475 (FC375/ (Page 168)), or a software package. The recommended software package is the SIMATIC Process Device Manager (PDM) by Siemens.

#### 7.15.1.1 HART Version

SITRANS LUT400 conforms to HART rev. 7.2.

#### 7.15.1.2 Burst mode

SITRANS LUT400 does not support burst mode.



### 7.15.1.3 HART multi-drop mode

HART Multi-drop Mode allows the connection of multiple field devices through HART. To setup a device in Multi-drop Mode, see Device Address (Page 162). Details on the use of Multi-drop Mode are outlined in an application guide **Working with HART**, which can be downloaded from the product page of our website. Go to: [www.siemens.com/sitransLUT400](http://www.siemens.com/sitransLUT400) ([www.siemens.com/sitransLUT400](http://www.siemens.com/sitransLUT400)) under **Support** and click on **Application Guides**.

### 7.15.1.4 SIMATIC PDM

This software package is designed to permit easy configuration, monitoring, and troubleshooting of HART devices. The HART EDD for SITRANS LUT400 was written with SIMATIC PDM in mind and has been extensively tested with this software.

For more information, see Operation via SIMATIC PDM 6 (HART) (Page 164).

### 7.15.1.5 HART Electronic Device Description (EDD)

In order to configure a HART device, the configuration software requires the HART Electronic Device Description for the instrument in question.

You can download the HART EDD for SITRANS LUT400 from the product page of our website. Go to: [www.siemens.com/sitransLUT400](http://www.siemens.com/sitransLUT400) ([www.siemens.com/sitransLUT400](http://www.siemens.com/sitransLUT400)) and click on **Support > Software Downloads**.

Older versions of the library will have to be updated in order to use all the features of SITRANS LUT400.

### 7.15.1.6 HART Status

Information on HART Status is outlined in an application guide **Working with HART**, which can be downloaded from the product page of our website. Go to: [www.siemens.com/sitransLUT400](http://www.siemens.com/sitransLUT400) ([www.siemens.com/sitransLUT400](http://www.siemens.com/sitransLUT400)) under **Support** and click on **Application Guides**.

## 7.15.2 LUT400 Communication connections

The SITRANS LUT400 can be connected to a computer system via a HART modem (connected to the mA OUT/HART terminal block), or directly connected via a Universal Serial Bus (USB) cable (for use with the Web Browser interface). A HART network requires a device address be configured. For communications via USB, connect SITRANS LUT400 to your computer via the USB cable.

### 7.15.3 Configuring communication ports

#### 7.15.3.1 HART modem

---

**Note**

It is recommended that only HCF registered modems be used.

---

#### Device Address

The unique identifier of the SITRANS LUT400 on a HART network.

Values	Range: <b>0</b> to <b>63</b> (Set within range of 0 to 15 if HART 5 master used.)
	Default: <b>0</b>

Set the device address or poll ID on a HART network.

Prior to HART 6, the device address was set to 0 for point to point operation. For HART Multi-drop mode, the device was set to any value other than 0 within the range. (Setting a non-zero address forced the device into fixed current mode.)

With HART 6 and above (version 7.2 supported by LUT400), Multi-drop mode no longer depends on the device address. (However, it is recommended that a non-zero address be set to avoid confusion based on previous HART requirements).

To set the LUT400 in Multi-drop mode, **disable Loop current mode** via one of the HART communication software tools (such as SIMATIC PDM). When *Loop current mode* is disabled, a low fixed current is used, allowing for multiple devices to be connected.

---

**Note**

Loop current mode cannot be disabled via LUI or Web Browser.

---

#### See also

Device Address (4.1.) (Page 264)

#### 7.15.3.2 USB cable

See Communications (Page 41) for typical setup via USB, then follow instructions under Installing the USB driver in the LUT400 Communications manual<sup>1</sup>.

<sup>1</sup>) Communications for SITRANS LUT400 (HART) Manual (7ML19985NE01).

#### **7.15.4 Communication troubleshooting**

See Communication Troubleshooting (Page 271) of Diagnosing and Troubleshooting (Page 271).

# Remote Operation

SITRANS LUT400 supports several software tools for operation via remote communications:

- PC running SIMATIC PDM
- PC running Emerson AMS Device Manager
- PC running a web browser
- PC running a Field Device Tool (FDT)
- Field Communicator 375/475 (FC375/FC475).

This section of the manual covers basic information required to use these tools with your SITRANS LUT400. Further details for each are available in the Communications for SITRANS LUT400 (HART) Manual (7ML19985NE01). (See DVD shipped with device or download manual from product page of our website: Go to [www.siemens.com/sitransLUT400](http://www.siemens.com/sitransLUT400) > **Technical Info** > **Manuals/Operating instructions.**)

---

## Note

Italian, Portuguese and Russian are not supported in the software tools for remote operation. If the device is set to one of these languages, it may be necessary to switch the device to English, German, French, Spanish or Chinese.

---

## 8.1 Operation via SIMATIC PDM 6 (HART)

(SITRANS LUT400 compatible with PDM version 6.1)

### Features and Functions

SIMATIC PDM is a software package used to commission and maintain SITRANS LUT400 and other process devices. PDM monitors the process values, alarms and status signals of the device. It allows you to display, compare, adjust, verify, and simulate process device data; also to set schedules for calibration and maintenance. Please consult the LUT400 online help for details on using SIMATIC PDM. (You can find more information at: [www.siemens.com/simatic-pdm](http://www.siemens.com/simatic-pdm) ([www.siemens.com/simatic-pdm](http://www.siemens.com/simatic-pdm)).)

SIMATIC PDM features four Quick Start Wizards (Level, Volume, Volume-Linearization, and Flow) to easily configure the SITRANS LUT400. A Pump Control Wizard is also available. Other features include Echo Profile Utilities, Manual TVT Shaper adjustment, Auto False Echo Suppression screening, Process Variables monitoring, and Maintenance scheduling.

Parameters are identified by name and organized into function groups. The menu structure for SIMATIC PDM is almost identical to that of the LCD. See LCD Menu Structure (Page 313) for a chart. For a complete list of parameters, see Parameter reference (LUI) (Page 171).

## 8.1.1 Startup and Configuration

To startup the SITRANS LUT400 using SIMATIC PDM, check that you have the latest version of PDM installed (update your installation if necessary - see SIMATIC PDM version (Page 165) SIMATIC PDM version below), then install the EDD. Next, configure the device using the Quick Start Wizards in PDM.

For more information on SIMATIC PDM functions, and details on how to configure the device using PDM, refer to the LUT400 Communications manual<sup>1</sup>.

<sup>1</sup>) Communications for SITRANS LUT400 (HART) Manual (7ML19985NE01).

### 8.1.1.1 SIMATIC PDM version

Check the support page of our website to make sure you have the latest version of SIMATIC PDM, the most recent Service Pack (SP) and the most recent hot fix (HF). Go to: SIMATIC PDM (<http://support.automation.siemens.com/WW/llisapi.dll?func=cslib.csinfo&lang=en&objid=10806857&subtype=133100>)

### 8.1.1.2 Electronic Device Description (EDD)

You can locate the EDD in Device Catalog, under Sensors/Level/Echo/Siemens AG/ SITRANS LUT400. (The EDD is written for forward compatibility.)

As a guideline to locate the correct EDD, the major and minor numbers should match between the EDD revision and the Firmware revision in the device (For example: major and minor numbers in bold text: 1.00.00-04).

To check it in PDM, go to **SITRANS LUT400 HART > Identification > Device**.

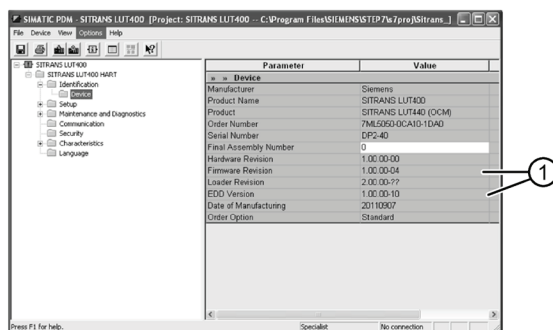

① Matching Firmware and EDD revisions

Installing a new version of **SIMATIC PDM** requires the most recent Service Pack (SP) and the most recent hot fix (HF).

**To install a new EDD**

- Go to [www.siemens.com/sitransLUT400](http://www.siemens.com/sitransLUT400) ([www.siemens.com/sitransLUT400](http://www.siemens.com/sitransLUT400)) > **Support** > **Software Downloads** to download the most up-to-date EDD from the product page of our website.
- Save the files to your computer and extract the zipped file to an easily accessed location.
- Launch **SIMATIC PDM – Manage Device Catalog**, browse to and select the folder which contains the unzipped EDD file.

## 8.2 Operation via Web Browser (USB)

### 8.2.1 Features and Functions

The web browser interface in SITRANS LUT400, designed to work with Windows XP, makes monitoring and adjustments easy. Internet Explorer installed on a computer can be used to configure the SITRANS LUT400, and the Web Server *Abyss* is supplied for your convenience. The web browser is available in English only.

SITRANS LUT400 parameters, organized into six main function groups, allow you to configure and monitor the device:

- Identification
- Setup
- Maintenance and Diagnostics
- Communication
- Security
- Language

### 8.2.2 Startup and Configuration

To start up the SITRANS LUT400 using the Web Browser, you must first install the USB driver and web browser interface. On the small DVD shipped with the device you will find the driver and installation software<sup>1</sup>. Once installed, the communication port (COMPORT) must be set, then you can configure the device via the browser menu parameters.

The menu structure for the web browser interface is almost identical to that of the LCD. See *Browser Menu Parameter Function Groups* in the LUT400 Communications manual<sup>2</sup> for a complete list of parameters that can be configured via the web browser.

For installation instructions and details on how to configure the device via the Web Browser, refer to the LUT400 Communications manual<sup>1</sup>.

<sup>1)</sup> Also available from the product page of our website. Go to: [www.siemens.com/sitransLUT400](http://www.siemens.com/sitransLUT400) ([www.siemens.com/sitransLUT400](http://www.siemens.com/sitransLUT400)) and click on **Support > Software Downloads**.

<sup>2)</sup> Communications for SITRANS LUT400 (HART) Manual (7ML19985NE01).

## 8.3 Operation via AMS Device Manager (HART)

### 8.3.1 Features and Functions

#### SITRANS LUT400 compatible with AMS version 10.5 and higher

AMS Device Manager is a software package used to commission and maintain SITRANS LUT400 and other process devices. AMS Device Manager monitors the process values, alarms and status signals of the device. It allows you to display, compare, adjust, verify, and simulate process device data. The graphic interface in SITRANS LUT400 makes monitoring and adjustments easy. Please consult the operating instructions or online help for details on using AMS Device Manager. (You can find more information at: <http://www.emersonprocess.com/AMS/> (<http://www.emersonprocess.com/AMS/>).)

AMS Device Manager features four Quick Start Wizards (Level, Volume, Volume-Linearization, and Flow) to easily configure the SITRANS LUT400. A Pump Control Wizard is also available. Other features include Echo Profile viewing, TVT setup, Process Variables monitoring, and Security.

Parameters organized into three main function groups allow you to configure and monitor the device:

- Configure/Setup
- Device Diagnostics (read only)
- Process Variables (read only)

For a chart<sup>1</sup> of the *AMS Menu Structure*, see LUT400 Communications manual<sup>2</sup>.

<sup>1)</sup> The menu structure for AMS Device Manager is almost identical to that of the LCD.

<sup>2)</sup> Communications for SITRANS LUT400 (HART) Manual (7ML19985NE01).

### 8.3.2 Startup and Configuration

To startup the SITRANS LUT400 using AMS Device Manager, you must first install the EDD (see below). You can then configure the device using the Quick Start Wizards in AMS.

For more information on AMS functions, and details on how to configure the device using AMS, refer to the LUT400 Communications manual<sup>2</sup>.

<sup>2)</sup> Communications for SITRANS LUT400 (HART) Manual (7ML19985NE01).

### 8.3.2.1 Electronic Device Description (EDD)

SITRANS LUT400 requires the EDD for AMS Device Manager version 10.5.

You can locate the EDD in Device Catalog, under **Sensors/Level/Echo/Siemens/SITRANS LUT400**. Check the product page of our website at [www.siemens.com/sitransLUT400](http://www.siemens.com/sitransLUT400) ([www.siemens.com/sitransLUT400](http://www.siemens.com/sitransLUT400)), under **Support > Software Downloads**, to make sure you have the latest version of the EDD for AMS Device Manager.

## 8.4 Operation via Field Communicator 375/475 (FC375/

### 8.4.1 Features and Functions

The FC375/FC475 HART Communicator is a handheld communication device that is easy to use, and provides universal support for other HART devices, such as the SITRANS LUT400.

For a list of parameters available with the Field Communicator, see *HART FC375/FC475 Menu Structure* in the LUT400 Communications manual<sup>1</sup>. This menu structure is very similar to that of AMS Device Manager.

<sup>1</sup>) Communications for SITRANS LUT400 (HART) Manual (7ML19985NE01).

### 8.4.2 Startup and Configuration

In order to configure this HART device, just as with AMS, the configuration software requires the HART Electronic Device Description (EDD) for the instrument. Once the EDD is installed, you can configure the device using the Quick Start Wizards within FC375/475.

For instructions on how to install the EDD, and how to configure a new device using FC375/475, refer to the LUT400 Communications manual<sup>2</sup>.

<sup>2</sup>) Communications for SITRANS LUT400 (HART) Manual (7ML19985NE01).



## 8.5 Operation via FDT (Field Device Tool)

### 8.5.1 Features and Functions

FDT is a standard used in several software packages designed to commission and maintain field devices such as SITRANS LUT400. Two commercially available FDTs are PACTware and Fieldcare.

FDT is very similar to PDM [see *Operation via SIMATIC PDM 6 (HART)* in the LUT400 Communications manual<sup>1</sup> for more detail].

- To configure a field device via FDT, you need the DTM (Device Type Manager) for the device.
- To configure a field device via SIMATIC PDM, you need the EDD (Electronic Data Description) for the device.

<sup>1</sup>) Communications for SITRANS LUT400 (HART) Manual (7ML19985NE01).

### 8.5.2 Startup and Configuration

To startup the SITRANS LUT400 using an FDT, you must first install the DTM (see below). You can then configure the device using the parameters available with the FDT.

The full process to configure a field device via FDT is outlined in an application guide for SITRANS DTM, which can be downloaded from the product page of our website. Go to: [www.siemens.com/sitransLUT400](http://www.siemens.com/sitransLUT400) ([www.siemens.com/sitransLUT400](http://www.siemens.com/sitransLUT400)) under **Support** and click on **Application Guides**.

#### 8.5.2.1 Device Type Manager (DTM)

A DTM is a type of software that 'plugs into' FDT. It contains the same information as an EDD but an EDD is independent of the operating system.

#### 8.5.2.2 SITRANS DTM version 3.1

- SITRANS DTM is an EDDL interpreter developed by Siemens to interpret the EDD for that device.
- To use SITRANS DTM to connect to a device, you must first install SITRANS DTM on your system and then install the instrument EDD written for SITRANS DTM.
- You can download SITRANS DTM from our website at:  
<http://www.siemens.com/sitransdtm> (<http://www.siemens.com/sitransdtm>).

Click on **Support** then go to **Software downloads**.

### 8.5.2.3 Electronic Device Description (EDD)

The SITRANS LUT400 HART EDD for SITRANS DTM can be downloaded from the product page of our website.

Go to [www.siemens.com/sitransLUT400](http://www.siemens.com/sitransLUT400) ([www.siemens.com/sitransLUT400](http://www.siemens.com/sitransLUT400)) under **Support** and click on **Software Downloads**.

## Parameter reference (LUI)

---

### Note

- Parameter names and menu structure are almost identical for SIMATIC PDM and the local user interface (LUI). Access is described below for some parameters that do not appear in the SIMATIC PDM menu structure. (**For further details on using these parameters within SIMATIC PDM, see the LUT400 Communications manual<sup>1</sup>.**)
- Default settings in the parameter tables are indicated with an asterisk (\*) unless explicitly stated.
- Parameter range values are displayed in the default of the defined unit of measure. For example, if a parameter description states that it is defined in Units (2.1.1.) (Page 172), the range for that parameter will be shown in meters [as meters (M) is the default for Units (2.1.1.) (Page 172)].
- The number of decimals displayed for a parameter value will depend on the unit of measure, unless decimal places can be set by the user (For example: Totalizers - Totalizer Decimal Position (2.7.3.2.) (Page 199) 2.7.3.2.Totalizer Decimal Position).

For example:

Values defined in default Units (2.1.1.) (Page 172) will display 3 decimal places; default Volume Units (2.6.2.) (Page 186) - 1 decimal place, default Flowrate Units (2.15.3.7.) (Page 238) - 0 decimal places.

- To enter Program mode using the local push buttons, press ►. Press ◀ to return to Measurement mode.
- 

<sup>1</sup>) Communications for SITRANS LUT400 (HART) Manual (7ML19985NE01)

Parameters are identified by name and organized into function groups. See LCD menu structure (Page 313) for a chart.

Parameters accessible via the local push buttons are preceded by a number. Parameters not preceded by a number are accessible only via remote operation.

Based on model configuration (LUT420, LUT430, LUT440), some parameters will not appear on LUI. Exceptions are noted by parameter.

Where the same parameter exists for more than one model, but is represented by a different menu number, both parameters are listed together (separated by "OR"), and the details are noted under the second of the two parameters.

For more details see:

- Operation via SIMATIC PDM 6 (HART) (Page 164)
- Operation via AMS Device Manager (HART) (Page 167)

9.1 Wizards (1.)

## 9.1 Wizards (1.)

Several Wizards are available with the SITRANS LUT400. Wizards group together all the settings needed for a particular feature. All Wizards are available via the local push buttons, and many are also available via SIMATIC PDM under the Device menu.

For details on the Wizards listed below, see Quick Start Wizards (Page 58) of Commissioning.

**QS Level (1.1.1.)**

**QS Volume (1.1.2.)**

**QS Flow (1.1.3.)** Available only on LUT430 (Pump and Flow) and LUT440 (OCM) configured models.

**Pump control (1.2.)**

## 9.2 Setup (2.)

---

**Note**

- See Local Commissioning (Page 50) or Operation via SIMATIC PDM 6 (HART) (Page 164) for instructions.
  - Default settings in the parameter tables are indicated with an asterisk (\*) unless explicitly stated.
  - Values shown in the following tables can be entered via the local push buttons.
- 

### 9.2.1 Sensor (2.1)

#### 9.2.1.1 Units (2.1.1.)

Determines sensor measurement units used when Sensor Mode (2.1.2.) (Page 173) set to Level, Space, Distance, or Head.

<b>Options</b>	m, cm, mm, ft, in
	Default: m

**9.2.1.2 Sensor Mode (2.1.2.)**

Menu number 2.1.2. visible on LUT420 (Level model).

OR

**9.2.1.3 Sensor Mode (2.1.3.)**

Menu number 2.1.3. visible on LUT430 (Pump and Flow model), and LUT440 (OCM model).

Sets the type of measurement required for the application.

Options (Mode)	Description	Reference point
* LEVEL	Distance to material surface	Low Calibration Point (process empty level)
SPACE		High Calibration Point (process full level)
DISTANCE		Sensor Reference Point
VOLUME	Volume of material in volumetric units (based on level)	Low Calibration Point
HEAD <sup>1</sup>	Distance to material surface	Zero Head
FLOW <sup>1</sup>	Flowrate in an open channel in Flowrate Units	Zero Head (zero flow level)

<sup>1)</sup> Option available only on LUT430, LUT440.

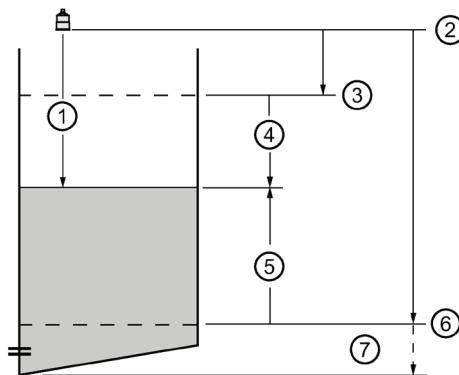

- ① Distance
- ② Sensor reference point
- ③ High calibration point
- ④ Space
- ⑤ Level
- ⑥ Low calibration point
- ⑦ Far range

9.2 Setup (2.)

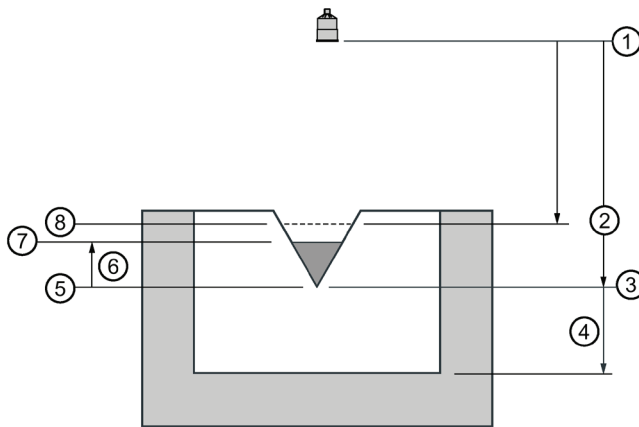

- ① Sensor reference point
- ② High calibration point
- ③ Low calibration point
- ④ Far range
- ⑤ Zero head
- ⑥ Head
- ⑦ Material surface
- ⑧ Maximum head

**9.2.1.4 Sensor Mode Secondary (2.1.4.)**

Menu number 2.1.4. visible on LUT420 (Level model).

OR

**9.2.1.5 Sensor Mode Secondary (2.1.5.)**

Menu number 2.1.5. visible on LUT430 (Pump and Flow model), and LUT440 (OCM model).

Sets the secondary measurement type to be used in the application.

See Sensor Mode (2.1.3.) (Page 173) for illustration.

**9.2.1.6 Transducer (2.1.6.)**

Specifies the Siemens transducer connected to the device.

<b>Options</b>	*	NO TRANSDUCER
		XRS-5
		XPS-10
		XPS-15
		XCT-8
		XCT-12

	XPS-30
	XPS-40
	XLT-30
	XLT-60
	STH

**Note**

- When **Transducer (2.1.6.)** is set to NO TRANSDUCER, the LOE fault will display immediately.
- An Echo Profile (3.2.1.) (Page 246) cannot be requested from LUI when **Transducer (2.1.6.)** is set to NO TRANSDUCER. The local push button will not operate.

**9.2.1.7 Frequency (2.1.7.)**

Adjust the shot transmit pulse frequency (in kHz).

<b>Values</b>	Range: <b>10.000</b> to <b>52.000</b>
	Default: Depends on transducer selected in Transducer (2.1.6.) (Page 174).

**9.2.1.8 Long Shot Duration (2.1.8.)**

Adjust the duration of the long shot transmit pulse (in  $\mu$ s).

<b>Values</b>	Range: <b>100.000</b> to <b>2000.000</b>
	Default: Depends on transducer selected in Transducer (2.1.6.) (Page 174).

**9.2.1.9 Short Shot Duration (2.1.9.)**

Adjust the duration of the short shot transmit pulse (in  $\mu$ s).

<b>Values</b>	Range: <b>100.000</b> to <b>2000.000</b>
	Default: Depends on transducer selected in Transducer (2.1.6.) (Page 174).

9.2 Setup (2.)

**9.2.2 Calibration (2.2.)**

**9.2.2.1 Low Calibration Point (2.2.1.)**

Distance from sensor reference point<sup>1</sup> to Low Calibration Point defined in Units (2.1.1.) (Page 172).

<b>Values</b>	Range: <b>0.000</b> to <b>60.000</b>
	Default: <b>60.000</b>

<sup>1</sup>The point from which level measurement is referenced (see Sensor Mode (2.1.2.) (Page 173) for illustration).

**9.2.2.2 High Calibration Point (2.2.2.)**

Distance from sensor reference point<sup>1</sup> to High Calibration Point defined in Units (2.1.1.) (Page 172).

<b>Values</b>	Range: <b>0.000</b> to <b>60.000</b>
	Default: <b>0.000</b>

When setting the High Calibration Point value, note that echoes are ignored within Near Range (2.2.4.) (Page 176).

<sup>1</sup>The point from which level measurement is referenced (see Sensor Mode (2.1.2.) (Page 173) for illustration).

**9.2.2.3 Sensor Offset (2.2.3.)**

The value altered when an Auto Sensor Offset (2.2.6.) (Page 177) is performed, defined in Units (2.1.1.) (Page 172).

<b>Values</b>	Range: <b>-99.999</b> to <b>99.999</b>
	Default: <b>0.000</b>

Alternatively, if amount of Sensor Offset is known, enter the constant that can be added to or subtracted from sensor value<sup>1</sup> to compensate if the sensor reference point has shifted.

<sup>1</sup>The point from which level measurement is referenced (see Sensor Mode (2.1.2.) (Page 173) for illustration).

**9.2.2.4 Near Range (2.2.4.)**

The range in front of the device (measured from the sensor reference point) within which any echoes will be ignored. This is sometimes referred to as blanking or a dead zone. Defined in Units (2.1.1.) (Page 172).

<b>Options</b>	Range: <b>0.000</b> to <b>60.000</b>
	Default: <b>0.300</b>



### 9.2.2.5 Far Range (2.2.5.)

---

#### Note

Far Range can extend beyond the bottom of the vessel.

---

Allows the material level to drop below Low Calibration Point without generating a Loss of Echo (LOE) state. See Sensor Mode (2.1.2.) (Page 173) for an illustration. Defined in Units (2.1.1.) (Page 172).

<b>Options</b>	Range: Min. = Low Calibration Point
	Max. = 61.000 M (200.13 FT)
	Default: Value for Low Calibration Pt. + 1 m (3.281 ft.)

Use this feature if the measured surface can drop below the Low Calibration Point in normal operation.

### 9.2.2.6 Auto Sensor Offset (2.2.6.)

---

#### Note

Auto Sensor Offset supports adjustments to distance value only.

---

Calibrates actual distance if reported value is consistently high or low by a fixed amount. (Adjusts distance measurement by a fixed amount.) Defined in Units (2.1.1.) (Page 172).

<b>Options</b>	Range: <b>0.000</b> to <b>60.000</b>
----------------	--------------------------------------

**Before using this feature, verify the following parameters are correct:**

- Low Calibration Point (2.2.1.) (Page 176) (or Zero Head Offset (2.15.3.5.) (Page 237), if using OCM)
- Process Temperature (2.12.1.2.) (Page 222)
- Sensor Offset (2.2.3.) (Page 176)

A correction to any one of these parameters may resolve the issue and an Auto Sensor Offset calibration may not be necessary.

#### Using Auto Sensor Offset:

Begin with a steady distance at a known low distance value (low distance value equates to a high level value).

1. Review the distance measurement via LUI for approximately 30 seconds to verify repeatability.
2. Measure the actual distance (for example, with a tape measure).
3. Enter the actual distance, defined in Units (2.1.1.) (Page 172).

The deviation between the calculated and the actual distance value is stored in Sensor Offset (2.2.3.) (Page 176).

### 9.2.3 Rate (2.3.)

---

#### Note

Default settings in the parameter tables are indicated with an asterisk (\*) unless explicitly stated.

---

#### Note

- The following three rate parameters work in conjunction, and are affected by Response Rate (set in the Quick Start (Page 59)).
  - Fill Rate per Minute (2.3.1.) (Page 178), Empty Rate per Minute (2.3.2.) (Page 178), and Damping Filter (2.3.3.) (Page 178) automatically update when Response Rate is altered, but any change to these parameters will supersede a Quick Start (Page 59) set previously through the wizard.
  - For more information, see Measurement Response (Page 300).
- 

#### 9.2.3.1 Fill Rate per Minute (2.3.1.)

Defines the maximum rate at which the reported level is allowed to increase. Allows you to adjust the SITRANS LUT400 response to increases in the actual material level.

Options	Range: <b>0.000</b> to <b>99999.000</b> m/min
	Default: 0.100 m/min

Enter a value slightly greater than the vessel's maximum filling rate, in units per minute.

#### 9.2.3.2 Empty Rate per Minute (2.3.2.)

Defines the maximum rate at which the reported level is allowed to decrease. Adjusts the SITRANS LUT400 response to decreases in the actual material level.

Options	Range: <b>0.000</b> to <b>99999.000</b> m/min
	Default: 0.100 m/min

Enter a value slightly greater than the vessel's maximum emptying rate, in units per minute.

#### 9.2.3.3 Damping Filter (2.3.3.)

Use this to stabilize the reported level (displayed and analog output), due to level fluctuations (such as a rippling or splashing liquid surface), defined in seconds.

Options	Range: <b>0.0</b> to <b>7200.0</b>
	Default: <b>100.0</b>

## 9.2.4 Fail-Safe (2.4.)

The fail-safe parameters ensure that the devices controlled by the SITRANS LUT400 default to an appropriate state when a valid level reading is not available. The PV region on LUI will display dashes (-----) until the fail-safe fault has been cleared. (See General Fault Codes (Page 273) for a list of faults that will cause failsafe.)

### Note

When a Loss of Echo occurs Material Level (2.4.1.) (Page 179) determines the material level to be reported when the Fail-safe timer expires. See Loss of Echo (LOE) (Page 302) for more detail.

### 9.2.4.1 Material Level (2.4.1.)

#### Note

The default is a factory setting and depends whether or not your device was ordered as NAMUR NE43-compliant for Fail-safe.

Defines the mA output to use (shown in Current Output Value (2.5.8.) (Page 183)) when the Failsafe Timer expires and the device is still in an error condition.

<b>Options</b>	HI	<b>20.0 mA</b> (max. mA Limit)
	LO	<b>4.0 mA</b> (min. mA Limit)
	HOLD	Last valid reading
	VALUE	User-selected value [defined in Fail-Safe mA Value (2.4.3.) (Page 179): default 3.58 mA]
<b>Default</b>	VALUE (if ordered with NAMUR NE43 compliant fail-safe preset) HOLD (if ordered without NAMUR NE43 compliant fail-safe preset)	

### 9.2.4.2 LOE Timer (2.4.2.)

Sets the time to elapse since the last valid reading, before the Fail-safe Material Level is reported (defined in seconds).

<b>Values</b>	Range: <b>0 to 7200</b>
	Default: <b>100</b>

### 9.2.4.3 Fail-Safe mA Value (2.4.3.)

#### Note

Material Level (2.4.1.) (Page 179) must be set to **Value** for the Material Level (2.4.1.) (Page 179) value to be reported.

9.2 Setup (2.)

Allows the user to define the mA value to be reported when the Fail-safe timer expires.

Values	Range: <b>3.50</b> to <b>22.80</b> mA
	Default: <b>3.58</b>

**9.2.5 Current Output (2.5.)**

**Note**

Default settings in the parameter tables are indicated with an asterisk (\*) unless explicitly stated.

**9.2.5.1 Current Output Function (2.5.1.)**

Menu number 2.5.1. visible on LUT420 (Level model).

OR

**9.2.5.2 Current Output Function (2.5.2.)**

Menu number 2.5.2. visible on LUT430 (Pump and Flow model), and LUT440 (OCM model).  
 Alters the mA output/measurement relationship.

**Note**

- The various options have different reference points.
- Use caution when changing Current Output Function while the device is connected to a HART network. Current Output Function controls the primary value and the loop current for the device.

Options	Reference point	Description
MANUAL <sup>1</sup>	n/a	user can enter mA value for loop current.
* LEVEL	Low calibration point	measured as difference between the material level and Low Calibration Point (2.2.1.) (Page 176) , defined in Units (2.1.1.) (Page 172).
SPACE	High calibration point	measured as difference between the material level and High Calibration Point (2.2.2.) (Page 176), defined in Units (2.1.1.) (Page 172).
DISTANCE	Sensor reference point	measured as difference between the material level and sensor reference point, defined in Units (2.1.1.) (Page 172).
VOLUME	Low calibration point	converted from Level, defined in Length of the cylindrical section of a horizontal parabolic end vessel. See Vessel Shape (2.6.1.) (Page 184) for an illustration.

Options	Reference point	Description
HEAD <sup>2</sup>	Zero Head	measured as difference between the liquid level and Zero Head, defined in Units (2.1.1.) (Page 172).
FLOW	Zero Head	converted from Head, defined in Flowrate Units (2.15.3.7.) (Page 238).

<sup>1)</sup> When Current Output Function is set to Manual, a power cycle will reset this parameter to its previous value.

<sup>2)</sup> Option available only on LUT430, LUT440.

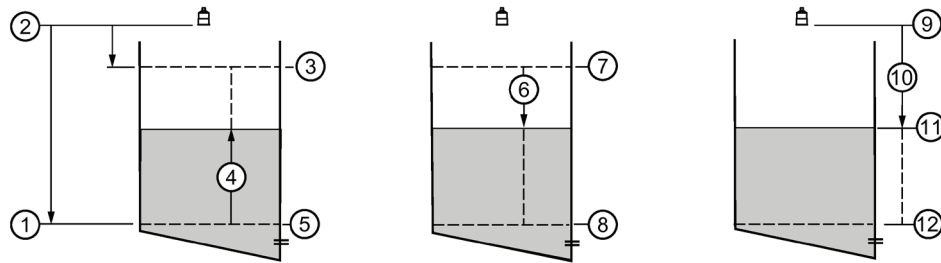

- ① Low calibration point
- ② Sensor reference point
- ③, ⑧, ⑫ 20 mA 100%
- ④ Level
- ⑤, ⑦, ⑨ 4 mA 0%
- ⑥ Space
- ⑩ Distance
- ⑪ Material Level

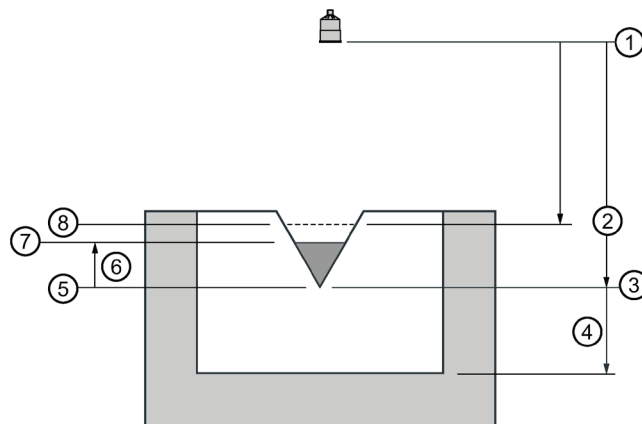

- ① Sensor reference point
- ② High calibration point
- ③ Low calibration point
- ④ Far range
- ⑤ Zero head
- ⑥ Head
- ⑦ Material surface
- ⑧ Maximum head

9.2 Setup (2.)

<sup>1)</sup> Refer to PMD supplier documentation for maximum head.

**To modify Current Output Function via SIMATIC PDM:**

Open the menu **Device – Select Analog Output.**

**9.2.5.3 4 mA Setpoint (2.5.3.)**

Sets the process level corresponding to the 4 mA value. 4 mA always defaults to **0 m**, and Current Output Function (2.5.1.) (Page 180) determines the type of measurement. [See Current Output Function (2.5.1.) (Page 180) for an illustration.]

<b>Values</b>	Range: Level, Space, Distance, Head: 0.000 to 60.000 m Volume: 0.0 to Max. Volume Flow: 0 to Max. Flow
	Default: <b>0</b> (set to value corresponding to 0% as defined by Current Output Function and associated units)

- Enter the reading that is to correspond to a 4 mA output.
- Units are defined in Units (2.1.1.) (Page 172) for Level, Space, Distance, or Head, and in Flowrate Units (2.15.3.7.) (Page 238) for Flow. Volume units are converted from a level value.

**9.2.5.4 20 mA Setpoint (2.5.4.)**

Sets the process level corresponding to the 20 mA value. 20 mA always defaults to **60 m**, and Current Output Function (2.5.1.) (Page 180) determines the type of measurement. [See Current Output Function (2.5.1.) (Page 180) for an illustration.]

<b>Values</b>	Range: Level, Space, Distance, Head: 0.000 to 60.000 m Volume: 0.0 to Max. Volume Flow: 0 to Max. Flow
	Default: Level, Space, Distance, Head: <b>60.000</b> Volume: <b>Max. Volume</b> Flow: <b>Max Flow</b> (set to value corresponding to 100% as defined by Current Output Function and associated units)

- Enter the reading that is to correspond to a 20 mA output.
- Units are defined in Units (2.1.1.) (Page 172) for Level, Space, or Distance, or Head, and in Flowrate Units (2.15.3.7.) (Page 238) for Flow. Volume units are converted from a level value.

**9.2.5.5 Minimum mA Limit (2.5.5.)**

Prevents the mA output from dropping below this minimum level for a measurement value. This does not restrict the Fail-safe or Manual settings.

Values	Range: <b>3.5 to 22.8 mA</b>
	Default: <b>4.0</b>

**9.2.5.6 Maximum mA Limit (2.5.6.)**

Prevents the mA output from rising above this maximum level for a measurement value. This does not restrict the Fail-safe or Manual settings.

Values	Range: <b>3.5 to 22.8 mA</b>
	Default: <b>20.0</b>

**9.2.5.7 Manual Value (2.5.7.)**

The mA value to use when Current Output Function (2.5.1.) (Page 180) is set to **Manual**. Allows you to use a simulated value to test the functioning of the loop. You can enter 4 mA, 20 mA, or any other user-defined value within the range.

Values	Range: <b>3.5 to 22.8 mA</b>
	Default: <b>3.58</b>

1. First set Current Output Function (2.5.1.) (Page 180) to **Manual**.
2. Set this parameter to the desired mA value.
3. After completing the test, remember to reset Current Output Function (2.5.1.) (Page 180) to the previous setting.

**Via AMS Device Manager or FC375/475:**

Open the menu **Configure/Setup > Operation > Select Analog Output**.

**Via SIMATIC PDM:**

Open the menu **Device – Loop Test**.

**9.2.5.8 Current Output Value (2.5.8.)**

Read only. Displays the current mA value, including a simulated value entered to test the functioning of the loop.

Values	Range: <b>3.5 to 22.8 mA</b>
--------	------------------------------

### 9.2.6 Volume (2.6.)

Carries out a volume conversion from a level value.

**Note**

Default settings in the parameter tables are indicated with an asterisk (\*) unless explicitly stated.

#### 9.2.6.1 Vessel Shape (2.6.1.)

89Defines the vessel shape and allows the LUT400 to calculate volume instead of level. If None is selected, no volume conversion is performed. Select the vessel shape matching the monitored vessel or reservoir.

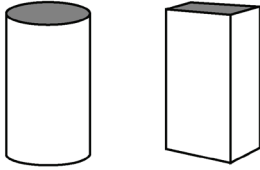
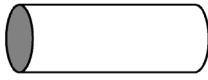
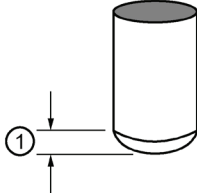
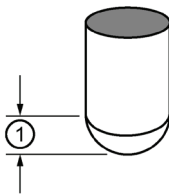
Vessel Shape		LCD Display/ Description	Also required
*	None	NONE/ No volume calculation required	N/A
		LINEAR/ Upright, linear (flat bottom)	maximum volume
		CYLINDER/ Flat end horizontal cylinder	maximum volume
		PARABOLIC BOTTOM	maximum volume, dimension A
		HALF SPHERE BOTTOM	maximum volume, dimension A

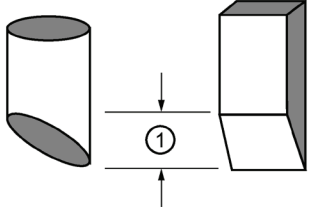
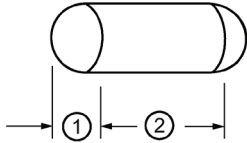
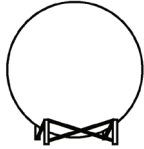
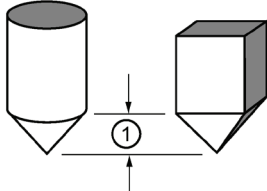
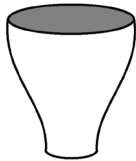
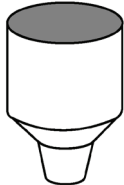

Vessel Shape	LCD Display/ Description	Also required
	FLAT SLOPED BOTTOM	maximum volume, dimension A
	PARABOLIC ENDS/ Parabolic end horizontal cylinder	maximum volume, dimension A, di- mension L
	SPHERE	maximum volume
	CONICAL BOTTOM/ Conical or pyramidal bottom	maximum volume, dimension A
	CURVE TABLE <sup>1)</sup> / Linearization table (level/volume break- points)	maximum volume, tables 1-32 level and volume break- points
	LINEAR TABLE <sup>1)</sup> / Linearization table (level/volume break- points)	maximum volume, tables 1-32 level and volume break- points

① Dimension A

② Dimension L

<sup>1)</sup> Linearization Table must be selected in order for level/volume values [see Table 1-8 (2.6.7.) (Page 187)] to be transferred.

9.2 Setup (2.)

**9.2.6.2 Volume Units (2.6.2.)**

Determines volume measurement units used when Sensor Mode (2.1.2.) (Page 173) set to **VOLUME**.

<b>Options</b>	*	L (Litres)
		USGAL (US Gallons)
		IMPGAL (Imperial Gallons)
		CUM (Cubic Meters)
		USER DEFINED (units defined in User Defined Unit (2.6.6.) (Page 187))

**9.2.6.3 Maximum Volume (2.6.3.)**

The maximum volume of the vessel. Enter the vessel volume corresponding to High Calibration Point. For example, if your maximum vessel volume is 8000 L, enter a value of 8000.

<b>Values</b>	Range: <b>0.0 to 9999999</b>
	Default: <b>100.0</b>

**9.2.6.4 Dimension A (2.6.4.)**

The height of the vessel bottom when the bottom is conical, pyramidal, parabolic, spherical, or flat -sloped. If the vessel is horizontal with parabolic ends, the depth of the end. See Vessel Shape (2.6.1.) (Page 184) for an illustration.

<b>Values</b>	Range: <b>0.0 to 99.999</b>
	Default: <b>0.000</b>

Defined in Units (2.1.1.) (Page 172).

**9.2.6.5 Dimension L (2.6.5.)**

Length of the cylindrical section of a horizontal parabolic end vessel. See Vessel Shape (2.6.1.) (Page 184) for an illustration.

<b>Values</b>	Range: <b>0.0 to 99.999</b>
	Default: <b>0.000</b>

Defined in Units (2.1.1.) (Page 172).

### 9.2.6.6 User Defined Unit (2.6.6.)

Set the unit text to display for current volume when Volume Units (2.6.2.) (Page 186) set to **user-defined**. Limited to 16 ASCII characters.

---

#### Note

The text entered is simply for display purposes. No unit conversion occurs.

---

### 9.2.6.7 Table 1-8 (2.6.7.)

If your vessel shape is more complex than any of the preconfigured shapes, you can define the shape as a series of segments. A value is assigned to each level breakpoint and a corresponding value is assigned to each volume breakpoint. Level values are defined in Units (2.1.1.) (Page 172). Volume values are defined in Volume Units (2.6.2.) (Page 186).

<b>Level Values</b>	Range: <b>0.000</b> to <b>60.000</b>
	Default: <b>0.000</b>
<b>Volume Values</b>	Range: <b>0.0</b> to <b>9999999.0</b>
	Default: <b>0.0</b>

Enter up to 32 level breakpoints, where the corresponding volume is known. The values corresponding to 0% and 100% levels must be entered, and breakpoints can be ordered from top to bottom, or the reverse.

Breakpoints are grouped into four tables: Table 1-8, Table 9-16, Table 17-24, and Table 25-32.

#### Entering breakpoints via SIMATIC PDM:

- See Using Linearization via the Quick Start wizard in the LUT400 Communications manual<sup>1</sup>.

#### Entering breakpoints via the local push buttons:

1. The default unit for level values is m: to change it navigate to Setup (2.) (Page 172) > Sensor (2.1) (Page 172) > Units (2.1.1.) (Page 172) , and select the desired unit.
2. Navigate to Setup (2.) (Page 172) > Volume (2.6.) (Page 184) > **Table 1-8 (2.6.7.)**, and enter the value.
3. Go to the appropriate table for the particular breakpoint you wish to adjust: for example, go to Table 1-8 for breakpoint 1.
4. Under Table 1-8, go to Level 1 (2.6.7.1.) (Page 188) to enter the level value for the breakpoint 1.
5. Under Table 1-8, go to Volume 1 (2.6.7.2.) (Page 188) to enter the volume value for the breakpoint 1.
6. Repeat steps 3 to 5, until values have been entered for all required breakpoints.

<sup>1</sup>) Communications for SITRANS LUT400 (HART) Manual (7ML19985NE01)

9.2 Setup (2.)

**Level 1 (2.6.7.1.)**

1. Press **RIGHT arrow** to open Edit mode.
2. Enter level value and press **RIGHT arrow** to accept it.
3. Press **Down ARROW** to move to corresponding volume breakpoint.

**Volume 1 (2.6.7.2.)**

1. Press **RIGHT arrow** to open Edit mode.
2. Enter volume value and press **RIGHT arrow** to accept it.
3. Press **Down ARROW** to move to next level breakpoint.

**Example**

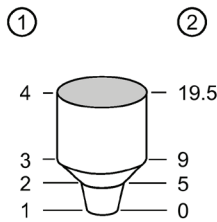

- ① Breakpoint Number
- ② Level Value

Breakpoint Number	Level value (m)	Volume value (l)
1	0	0
2	5	500
3	9	3000
4	19.5	8000

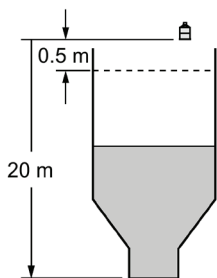

**9.2.6.8**

**Table 9-32**

- Table 9-16 (2.6.8.)
- Table 17-24 (2.6.9.)
- Table 25-32 (2.6.10.)

## 9.2.7 Pumps (2.7.)

### Note

Default settings in the parameter tables are indicated with an asterisk (\*) unless explicitly stated.

For details on relay behaviour under fail-safe conditions, see Pump relays (Page 88).

### 9.2.7.1 Basic Setup (2.7.1.)

#### Pump Control Enable (2.7.1.1)

Enables/disables pump control.

Options		ENABLED
	*	DISABLED

#### Relay Pump 1 (2.7.1.2)

Selects the relay assigned to Pump 1.

Options	*	RELAY 2
		RELAY 3

#### Relay Pump 2 (2.7.1.3)

Selects the relay assigned to Pump 2.

Options		RELAY 2
	*	RELAY 3

#### Pump Control Mode (2.7.1.4.)

Menu number 2.7.1.4. visible on LUT420 (Level model).

OR

#### Pump Control Mode (2.7.1.5.)

Menu number 2.7.1.5. visible on LUT430 (Pump and Flow model), and LUT440 (OCM model).

9.2 Setup (2.)

Sets the control algorithm used to trip the relay.

<b>Options</b>	*	ALTERNATE DUTY ASSIST (ADA)	At rotating ON and OFF setpoints and allows multiple pumps to run
		ALTERNATE DUTY BACKUP (ADB)	At rotating ON and OFF setpoints and allows only one pump to run
		SERVICE RATIO DUTY ASSIST (SRA) <sup>1</sup>	On service ratio at ON and OFF setpoints and allows multiple pumps to run
		SERVICE RATIO DUTY BACKUP (SRB) <sup>1</sup>	On service ratio at ON and OFF setpoints and allows only one pump to run
		FIXED DUTY ASSIST (FDA) <sup>1</sup>	At fixed ON and OFF setpoints and allows multiple pumps to run
		FIXED DUTY BACKUP (FDB) <sup>1</sup>	At fixed ON and OFF setpoints and allows only one pump to run

<sup>1)</sup> Option available only on LUT430, LUT440.

Each algorithm defines a pump duty and pump start method.

**ON Setpoint Pump 1 (2.7.1.6.)**

The level at which Pump 1 turns ON, defined in Units (2.1.1.) (Page 172).

<b>Values</b>	Range: <b>0.000 to 99999.000</b>
	Default: <b>0.000</b>

This parameter is set according to level even when another reading, such as volume, is shown on the LCD.

**OFF Setpoint Pump 1 (2.7.1.7.)**

The level at which Pump 1 turns OFF, defined in Units (2.1.1.) (Page 172).

<b>Values</b>	Range: <b>0.000 to 99999.000</b>
	Default: <b>0.000</b>

This parameter is set according to level even when another reading, such as volume, is shown on the LCD.

**ON Setpoint Pump 2 (2.7.1.8.)**

The level at which Pump 2 turns ON, defined in Units (2.1.1.) (Page 172).

<b>Values</b>	Range: <b>0.000 to 99999.000</b>
	Default: <b>0.000</b>

This parameter is set according to level even when another reading, such as volume, is shown on the LCD.

**OFF Setpoint Pump 2 (2.7.1.9.)**

The level at which Pump 2 turns OFF, defined in Units (2.1.1.) (Page 172).

<b>Values</b>	Range: <b>0.000</b> to <b>99999.000</b>
	Default: <b>0.000</b>

This parameter is set according to level even when another reading, such as volume, is shown on the LCD.

**Service Ratio Pump 1 (2.7.1.10.)**

Selects pump usage based on the RUN time ratio rather than last used. (See Run Time Relay 2 (3.2.7.1.) (Page 248).)

<b>Values</b>	Range: <b>0</b> to <b>255</b>
	Default: <b>1</b>

This parameter only relates to relays with Pump Control Mode (2.7.1.4.) (Page 189) set to Service Ratio Duty Assist or Service Ratio Duty Backup.

The number assigned to each pump relay represents the ratio applied to decide the next pump to start or stop.

**Note**

- The SITRANS LUT400 will not sacrifice other pumping strategies to ensure that the ratio is held true.
- If the pump relays are set to the same value then the ratio equals 1:1 and all pumps are used equally (default).

**Service Ratio Pump 2 (2.7.1.11.)**

Selects pump usage based on the RUN time ratio rather than last used. (See Run Time Relay 3 (3.2.7.2.) (Page 248).)

<b>Values</b>	Range: <b>0</b> to <b>255</b>
	Default: <b>1</b>

This parameter only relates to relays with Pump Control Mode (2.7.1.4.) (Page 189) set to Service Ratio Duty Assist or Service Ratio Duty Backup.

The number assigned to each pump relay represents the ratio applied to decide the next pump to start or stop.

**Note**

- The SITRANS LUT400 will not sacrifice other pumping strategies to ensure that the ratio is held true.
- If the pump relays are set to the same value then the ratio equals 1:1 and all pumps are used equally (default).

**9.2.7.2 Modifiers (2.7.2.)**

**Note**

Default settings in the parameter tables are indicated with an asterisk (\*) unless explicitly stated.

**Wall Cling Reduction**

**Enable (2.7.2.1.1)**

Enables/disables Level Setpoint Variation (2.7.2.1.2) (Page 192).

Options		ENABLED
	*	DISABLED

**Level Setpoint Variation (2.7.2.1.2)**

Varies the ON and OFF setpoints to reduce material buildup on the walls (defined in Units (2.1.1.) (Page 172)).

Values	Range: <b>0.000</b> to <b>99999.000</b>
	Default: <b>0.000</b>

This value is the range in which the setpoints are allowed to deviate. The pump ON and OFF Setpoint values are randomly varied inside the range to ensure that the material level does not consistently stop at the same point.

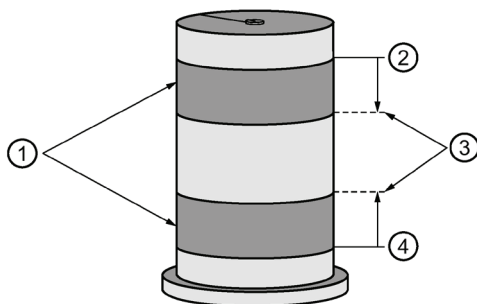

- ① Random setpoint range
- ② Level setpoint ON
- ③ Level setpoint variation
- ④ Level setpoint OFF



## Energy Savings

### Energy Savings (2.7.2.2.)

Available only on LUT430 (Pump and Flow model), and LUT440 (OCM model).

Use these parameters to maximize your device's operation during periods of low energy cost and minimize its operation during periods of high cost.

The methods used to achieve this are:

- Emptying the wet well just prior to the high cost period, regardless of material level (Peak Lead Time (2.7.2.2.2.) (Page 193)).
- Changing setpoints for high cost and low cost periods (Peak ON Setpoint Pump 1 (2.7.2.2.13.) (Page 196), Peak OFF Setpoint Pump 1 (2.7.2.2.14.) (Page 196), Peak 1 Start Time (2.7.2.2.3.) (Page 193), Peak 1 End Time (2.7.2.2.4.) (Page 194)).

One peak lead time is shared by all five peak zones. When one zone's peak time interval (difference between peak start time and peak end time) overlaps another zone's peak lead time, the lead time is chosen over the interval. If a zone's start time matches its end time, the zone is treated as not configured.

#### Enable (2.7.2.2.1.)

Enables/disables the Energy Savings feature. The Energy Savings feature is used to minimize the pumping that occurs during periods of high energy cost.

Options	*	DISABLED
		ENABLED

#### Peak Lead Time (2.7.2.2.2.)

The time in minutes before the Peak Start Time that the SITRANS LUT400 will begin pumping.

Values	Range: <b>0</b> to <b>65535</b>
	Default: <b>60</b>

This value determines when pumping should start to ensure the level is as far as possible from the ON Setpoint Pump 1 (2.7.1.6.) (Page 190). If level is already within 5% of OFF Setpoint Pump 1 (2.7.1.7.) (Page 190), no action occurs. If multiple pump stations are series linked, ensure the Peak Lead Time entered is sufficient to attain the desired level in all stations before the high-energy cost period occurs.

#### Peak 1 Start Time (2.7.2.2.3.)

Sets the start time of the high energy cost period 1.

Values	Range: <b>00:00</b> to <b>23:59</b>
	Format: HH:MM (24 hour format, for example: for 5:30pm, set parameter to <b>17:30</b> )
	Default: 00:00

9.2 Setup (2.)

Used in conjunction with Peak 1 End Time (2.7.2.2.4.) (Page 194) to define the high cost period.

For instructions on how to edit parameters with a string editor, see Using the string editor in Date and Time (2.14.) (Page 232).

**Peak 1 End Time (2.7.2.2.4.)**

Sets the end time of the high energy cost period 1.

<b>Values</b>	Range: <b>00:00</b> to <b>23:59</b>
	Format: HH:MM (24 hour format, for example: for 5:30pm, set parameter to <b>17:30</b> )
	Default: 00:00

Used in conjunction with Peak 1 Start Time (2.7.2.2.3.) (Page 193) to define the high cost period.

For instructions on how to edit parameters with a string editor, see Using the string editor in Date and Time (2.14.) (Page 232).

**Peak 2 Start Time (2.7.2.2.5.)**

Sets the start time of the high energy cost period 2.

<b>Values</b>	Range: <b>00:00</b> to <b>23:59</b>
	Format: HH:MM (24 hour format, for example: for 5:30pm, set parameter to <b>17:30</b> )
	Default: 00:00

Used in conjunction with Peak 2 End Time (2.7.2.2.6.) (Page 194) to define the high cost period.

**Peak 2 End Time (2.7.2.2.6.)**

Sets the end time of the high energy cost period 2.

<b>Values</b>	Range: <b>00:00</b> to <b>23:59</b>
	Format: HH:MM (24 hour format, for example: for 5:30pm, set parameter to <b>17:30</b> )
	Default: 00:00

Used in conjunction with Peak 2 Start Time (2.7.2.2.5.) (Page 194) to define the high cost period.

**Peak 3 Start Time (2.7.2.2.7.)**

Sets the start time of the high energy cost period 3.

<b>Values</b>	Range: <b>00:00</b> to <b>23:59</b>
	Format: HH:MM (24 hour format, for example: for 5:30pm, set parameter to <b>17:30</b> )
	Default: 00:00

Used in conjunction with Peak 3 End Time (2.7.2.2.8.) (Page 195) to define the high cost period.

### Peak 3 End Time (2.7.2.2.8.)

Sets the end time of the high energy cost period 3.

<b>Values</b>	Range: <b>00:00</b> to <b>23:59</b>
	Format: HH:MM (24 hour format, for example: for 5:30pm, set parameter to <b>17:30</b> )
	Default: 00:00

Used in conjunction with Peak 3 Start Time (2.7.2.2.7.) (Page 194) to define the high cost period.

### Peak 4 Start Time (2.7.2.2.9.)

Sets the start time of the high energy cost period 4.

<b>Values</b>	Range: <b>00:00</b> to <b>23:59</b>
	Format: HH:MM (24 hour format, for example: for 5:30pm, set parameter to <b>17:30</b> )
	Default: 00:00

Used in conjunction with Peak 4 End Time (2.7.2.2.10.) (Page 195) to define the high cost period.

### Peak 4 End Time (2.7.2.2.10.)

Sets the end time of the high energy cost period 4.

<b>Values</b>	Range: <b>00:00</b> to <b>23:59</b>
	Format: HH:MM (24 hour format, for example: for 5:30pm, set parameter to <b>17:30</b> )
	Default: 00:00

Used in conjunction with Peak 4 Start Time (2.7.2.2.9.) (Page 195) to define the high cost period.

### Peak 5 Start Time (2.7.2.2.11.)

Sets the start time of the high energy cost period 5.

<b>Values</b>	Range: <b>00:00</b> to <b>23:59</b>
	Format: HH:MM (24 hour format, for example: for 5:30pm, set parameter to <b>17:30</b> )
	Default: 00:00

Used in conjunction with Peak 5 End Time (2.7.2.2.12.) (Page 196) to define the high cost period.

**Peak 5 End Time (2.7.2.2.12.)**

Sets the end time of the high energy cost period 5.

<b>Values</b>	Range: <b>00:00 to 23:59</b>
	Format: HH:MM (24 hour format, for example: for 5:30pm, set parameter to <b>17:30</b> )
	Default: 00:00

Used in conjunction with Peak 5 Start Time (2.7.2.2.11.) (Page 195) to define the high cost period.

**Peak ON Setpoint Pump 1 (2.7.2.2.13.)**

Sets the process point at which Pump 1 will turn on when in a peak period.

<b>Values</b>	Range: <b>0.000 to 99999.000</b>
	Default: <b>0.000</b>

To allow the level to go beyond the normal Relay ON Setpoint before a pump is started, enter the value to be used for the high-energy cost period.

**Peak OFF Setpoint Pump 1 (2.7.2.2.14.)**

Sets the process point at which Pump 1 will turn off when in a peak period.

<b>Values</b>	Range: <b>0.000 to 99999.000</b>
	Default: <b>0.000</b>

To stop the pump(s) before the normal relay OFF Setpoint and reduce pump-running time. Enter the value to be used for the high cost period.

**Peak ON Setpoint Pump 2 (2.7.2.2.15.)**

Sets the process point at which Pump 2 will turn on when in a peak period.

<b>Values</b>	Range: <b>0.000 to 99999.000</b>
	Default: <b>0.000</b>

To allow the level to go beyond the normal Relay ON Setpoint before a pump is started, enter the value to be used for the high-energy cost period.

**Peak OFF Setpoint Pump 2 (2.7.2.2.16.)**

Sets the process point at which Pump 2 will turn off when in a peak period.

<b>Values</b>	Range: <b>0.000 to 99999.000</b>
	Default: <b>0.000</b>

To stop the pump(s) before the normal relay OFF Setpoint and reduce pump-running time. Enter the value to be used for the high cost period.

## Pump Run-On

Available only on LUT430 (Pump and Flow model) and LUT440 (OCM model).

For details on relay behaviour under fail-safe conditions, see Pump relays (Page 88).

### Enable (2.7.2.3.1.)

Enables/disables Pump Run-On.

Options		ENABLED
	*	DISABLED

### Run-On Interval (2.7.2.3.2.)

The number of hours between pump run-on occurrences.

Values	Range: <b>0.00</b> to <b>1000.00</b>
	Default: <b>0.00</b>

To clear sediment in a pump-down wet well, run the pump after the normal OFF setpoint is reached to force some solid material through. This parameter sets the time between such events. Only the last pump running can run-on.

### Run-On Duration Pump 1 (2.7.2.3.3.)

The number of seconds that the pump will run-on.

Values	Range: <b>0</b> to <b>65535</b>
	Default: <b>0</b>

Each pump capacity will determine the amount of material that can be removed. Choose a value long enough to clean out the vessel bottom, yet short enough not to run the pump dry. Also be sure that this value does not overlap with Run-On Interval (2.7.2.3.2.) (Page 197).

### Run-On Duration Pump 2 (2.7.2.3.4.)

The number of seconds that the pump will run-on.

Values	Range: <b>0</b> to <b>65535</b>
	Default: <b>0</b>

Each pump capacity will determine the amount of material that can be removed. Choose a value long enough to clean out the vessel bottom, yet short enough not to run the pump dry. Also be sure that this value does not overlap with Run-On Interval (2.7.2.3.2.) (Page 197).

## Pump Start Delays

Available only on LUT430 (Pump and Flow model), and LUT440 (OCM model).

### Delay Between Starts (2.7.2.4.1.)

The minimum delay (in seconds) between pump starts.

Values	Range: <b>0</b> to <b>65535</b>
	Default: <b>10</b>

Use this feature to reduce a power surge from all pumps starting at the same time. This delay determines when the next pump is permitted to start.

---

#### Note

If a delay is configured, it will be respected when in simulation mode (see Pump relay behaviour during simulation (Page 156)).

---

### Power Resumption Delay (2.7.2.4.2.)

The minimum delay (in seconds) before the first pump restart after a power failure.

Values	Range: <b>0</b> to <b>65535</b>
	Default: <b>60</b>

This reduces the power surge from multiple instruments starting their pumps immediately on power resumption. When this delay expires, other pumps will start as per Delay Between Starts (2.7.2.4.1.) (Page 198).

### 9.2.7.3 Totalizers (2.7.3.)

Available only on LUT430 (Pump and Flow model), and LUT440 (OCM model).

---

#### Note

Default settings in the parameter tables are indicated with an asterisk (\*) unless explicitly stated.

---

### Running Totalizer (2.7.3.1.)

Current pumped volume totalizer value in Volume Units (2.6.2.) (Page 186).

Values	Range: <b>0.00</b> to <b>999999999</b>
	Default: <b>0.00</b>

Pumped volume is automatically calculated whenever both Volume and Pumps are configured.

**Totalizer Decimal Position (2.7.3.2.)**

Sets the maximum number of decimal places to be displayed on the LCD.

Options		NO DIGITS	No digits after the decimal position
		1 DIGIT	1 digit after the decimal point
	*	2 DIGITS	2 digit after the decimal point
		3 DIGITS	3 digit after the decimal point

**Totalizer Multiplier (2.7.3.3.)**

Use this feature if the LCD Total increments by an amount that is too large (or too small).

Options		.001
		.01
		.1
	*	1
		10
		100
		1000
		10,000
		100,000
		1,000,000
		10,000,000

Enter the factor by which actual volume is divided, prior to display on LCD. Use a value such that the nine-digit totalizer doesn't roll over between readings.

**Example:**

For an LCD Total display in 1000s of volume units, enter **1000**. In this example, **10,000** volume units would display as **10**.

**Inflow/Discharge Adjust (2.7.3.4.)**

Determines how inflow (or discharge) adjustment is made.

Options	*	BASED ON RATE ESTIMATION	The inflow rate measured just prior to the start of the pump cycle is used to estimate the inflow for the duration of the cycle.
		BASED ON PUMP CYCLE	The inflow is calculated using the change of volume between the end of the last pump cycle and the start of the next one, and the time period between the last cycle and the current one.
		NO ADJUSTMENT	No inflow adjustment is made (assumes an inflow of zero).

For an illustration, see Pump Totalizers (Page 305).

### Reset Running Totalizer (2.7.3.5.)

Select **YES** to reset pumped volume totalizer value to zero.

Options	*	NO
		YES

## 9.2.8 Alarms (2.8.)

The SITRANS LUT400 supports eight alarm types. Any alarm can be assigned to any available relay.

It is possible to assign more than one alarm to the same relay. In this case, the relay will activate if any one of the alarms is activated. If no alarms are activated, the relay will become inactive.

For details on relay behaviour under fail-safe conditions, see Alarm relays (Page 87).

---

#### Note

Default settings in the parameter tables are indicated with an asterisk (\*) unless explicitly stated.

---

### 9.2.8.1 High Level Alarm (2.8.1.)

Reported when material level is within a user-defined range (see High Level Value ON (2.8.1.2) (Page 200) and High Level Value OFF (2.8.1.3) (Page 201)).

Can be used in conjunction with Time To Spill (2.8.12.) (Page 211).

#### Enable (2.8.1.1)

Enables/disables High Level Alarm.

Options		ENABLED
	*	DISABLED

#### High Level Value ON (2.8.1.2)

Sets the material level (defined in Units (2.1.1.) (Page 172)) at which the High Level Alarm will activate.

Values	Range: <b>0.000</b> to <b>99999.000</b>
	Default: <b>0.000</b>

Value must be lower than Level To Spill (2.8.12.1.) (Page 211) if Time to Spill feature is used.



**High Level Value OFF (2.8.1.3)**

Sets the material level (defined in Units (2.1.1.) (Page 172)) at which the High Level Alarm will de-activate.

Values	Range: <b>0.000</b> to <b>99999.000</b>
	Default: <b>0.000</b>

**Assigned Relay (2.8.1.4)**

Determines which relay (if any) will be activated when the High Level Alarm activates.

Options	*	NO RELAY
		RELAY 1
		RELAY 2
		RELAY 3

**Alarm State (2.8.1.5)**

Read only. Used to view the current state of the High Level Alarm.

Options	ACTIVE
	INACTIVE

**9.2.8.2 Low Level Alarms (2.8.2.)**

Reported when material level is within a user-defined range (see Low Level Value ON (2.8.2.2.) (Page 201) and Low Level Value OFF (2.8.2.3.) (Page 202)).

**Enable (2.8.2.1.)**

Enables/disables Low Level Alarm.

Options		ENABLED
	*	DISABLED

**Low Level Value ON (2.8.2.2.)**

Sets the material level (defined in Units (2.1.1.) (Page 172)) at which the Low Level Alarm will activate.

Values	Range: <b>0.000</b> to <b>99999.000</b>
	Default: <b>0.000</b>

9.2 Setup (2.)

**Low Level Value OFF (2.8.2.3.)**

Sets the material level (defined in Units (2.1.1.) (Page 172)) at which the Low Level Alarm will de-activate.

Values	Range: <b>0.000</b> to <b>99999.000</b>
	Default: <b>0.000</b>

**Assigned Relay (2.8.2.4.)**

Determines which relay (if any) will be activated when the Low Level Alarm activates.

Options	*	NO RELAY
		RELAY 1
		RELAY 2
		RELAY 3

**Alarm State (2.8.2.5.)**

Read only. Used to view the current state of the Low Level Alarm.

Options	ACTIVE
	INACTIVE

**9.2.8.3 Switch (Discrete Input) Alarm (2.8.3.)**

Reported when Discrete Input (Discrete Input Number (2.8.3.2.) (Page 202)) is in a predefined state (Discrete Input State (2.8.3.3.) (Page 203)).

**Enable (2.8.3.1.)**

Enables/disables Switch Alarm.

Options		ENABLED
	*	DISABLED

**Discrete Input Number (2.8.3.2.)**

Determines which discrete input to monitor for Switch Alarm.

Options	*	DISCRETE INPUT 1
		DISCRETE INPUT 2

**Discrete Input State (2.8.3.3.)**

Sets the state of the discrete input (Discrete Input Number (2.8.3.2.) (Page 202)) that will cause the Switch Alarm to activate.

Options	*	ON
		OFF

**Assigned Relay (2.8.3.4.)**

Determines which relay (if any) will be activated when the Switch Alarm activates.

Options	*	NO RELAY
		RELAY 1
		RELAY 2
		RELAY 3

**Alarm State (2.8.3.5.)**

Read only. Used to view the current state of the Switch Alarm.

Options	ACTIVE
	INACTIVE

**9.2.8.4 In-bounds Level Alarm (2.8.4.)**

Reported when material level is within a user-defined range (see High Level Value (2.8.4.2.) (Page 204) and Low Level Value (2.8.4.3.) (Page 204)).

**Enable (2.8.4.1.)**

Enables/disables In-bounds Level Alarm.

Options		ENABLED
	*	DISABLED

9.2 Setup (2.)

**High Level Value (2.8.4.2.)**

Sets the upper level value for range within which the In-bounds Level Alarm will activate.

Values	Range: <b>0.000</b> to <b>99999.000</b>
	Default: <b>0.000</b>

**Low Level Value (2.8.4.3.)**

Sets the lower level value for range within which the In-bounds Level Alarm will activate.

Values	Range: <b>0.000</b> to <b>99999.000</b>
	Default: <b>0.000</b>

**Assigned Relay (2.8.4.4.)**

Determines which relay (if any) will be activated when the In-bounds Level Alarm activates.

Options	*	NO RELAY
		RELAY 1
		RELAY 2
		RELAY 3

**Alarm State (2.8.4.5.)**

Read only. Used to view the current state of the In-bounds Level Alarm.

Options	ACTIVE
	INACTIVE

**9.2.8.5 Out-of-bounds Level Alarm (2.8.5.)**

Reported when material level is outside a user-defined range (see High Level Value (2.8.5.2.) (Page 205) or Low Level Value (2.8.5.3.) (Page 205)).

**Enable (2.8.5.1.)**

Enables/disables Out-of-bounds Level Alarm.

Options		ENABLED
	*	DISABLED

**High Level Value (2.8.5.2.)**

Sets the upper level value for range outside of which the Out-of-bounds Level Alarm will activate.

Values	Range: <b>0.000</b> to <b>99999.000</b>
	Default: <b>0.000</b>

**Low Level Value (2.8.5.3.)**

Sets the lower level value for range outside of which the Out-of-bounds Level Alarm will activate.

Values	Range: <b>0.000</b> to <b>99999.000</b>
	Default: <b>0.000</b>

**Assigned Relay (2.8.5.4.)**

Determines which relay (if any) will be activated when the Out-of-bounds Level Alarm activates.

Options	*	NO RELAY
		RELAY 1
		RELAY 2
		RELAY 3

**Alarm State (2.8.5.5.)**

Read only. Used to view the current state of the Out-of-bounds Level Alarm.

Options	ACTIVE
	INACTIVE

**9.2.8.6 Low Temperature Alarm (2.8.6.)**

Reported when process temperature is within a user-defined range (see Low Temperature Value ON (2.8.6.2.) (Page 206) or Low Temperature Value OFF (2.8.6.3.) (Page 206)).

**Enable (2.8.6.1.)**

Enables/disables Low Temperature Alarm.

Options		ENABLED
	*	DISABLED

9.2 Setup (2.)

**Low Temperature Value ON (2.8.6.2.)**

Sets the temperature value (defined in °C) at which the Low Temperature Alarm will activate.

Values	Range: <b>-273.0</b> to <b>+273.0</b> °C (-459.0 to +523.0 °F)
	Default: 0.0 °C

**Low Temperature Value OFF (2.8.6.3.)**

Sets the temperature value (defined in °C) at which the Low Temperature Alarm will deactivate.

Values	Range: <b>-273.0</b> to <b>+273.0</b> °C (-459.0 to +523.0 °F)
	Default: 0.0 °C

**Assigned Relay (2.8.6.4.)**

Determines which relay (if any) will be activated when the Low Temperature Alarm activates.

Options	*	NO RELAY
		RELAY 1
		RELAY 2
		RELAY 3

**Alarm State (2.8.6.5.)**

Read only. Used to view the current state of the Low Temperature Alarm.

Options	ACTIVE
	INACTIVE

**9.2.8.7 High Temperature Alarm (2.8.7.)**

Reported when process temperature is within a user-defined range (see High Temperature Value ON (2.8.7.2.) (Page 207) or High Temperature Value OFF (2.8.7.3.) (Page 207)).

The temperature used for the alarm is the same temperature used for sound velocity compensation (see Temperature Source (2.12.1.3.) (Page 222)).

**Enable (2.8.7.1.)**

Enables/disables High Temperature Alarm.

Options		ENABLED
	*	DISABLED

**High Temperature Value ON (2.8.7.2.)**

Sets the temperature value (defined in °C) at which the High Temperature Alarm will activate.

Values	Range: -273.0 to +273.0 °C (-459.0 to +523.0 °F)
	Default: 100.0 °C

**High Temperature Value OFF (2.8.7.3.)**

Sets the temperature value (defined in °C) at which the High Temperature Alarm will deactivate.

Values	Range: -273.0 to +273.0 °C (-459.0 to +523.0 °F)
	Default: 100.0 °C

**Assigned Relay (2.8.7.4.)**

Determines which relay (if any) will be activated when the High Temperature Alarm activates.

Options	*	NO RELAY
		RELAY 1
		RELAY 2
		RELAY 3

**Alarm State (2.8.7.5.)**

Read only. Used to view the current state of the High Temperature Alarm.

Options	ACTIVE
	INACTIVE

**9.2.8.8 Fail-safe Fault Alarm (2.8.8.)**

Reported when fault that has caused a fail-safe condition is present.

**Enable (2.8.8.1.)**

Enables/disables Fail-safe Alarm.

Options		ENABLED
	*	DISABLED

9.2 Setup (2.)

**Assigned Relay (2.8.8.2.)**

Determines which relay (if any) will be activated when the Fail-safe Alarm activates.

Options	*	NO RELAY
		RELAY 1
		RELAY 2
		RELAY 3

**Alarm State (2.8.8.3.)**

Read only. Used to view the current state of the Fail-safe Alarm.

Options	ACTIVE
	INACTIVE

**9.2.8.9 High Flowrate Alarm (2.8.9.)**

Available only on LUT440 (OCM model).

Reported when the OCM flowrate is within a user-defined range (see High Flowrate Value ON (2.8.9.2.) (Page 208) and High Flowrate Value OFF (2.8.9.3.) (Page 208)).

**Enable (2.8.9.1.)**

Enables/disables High Flowrate Alarm.

Options		ENABLED
	*	DISABLED

**High Flowrate Value ON (2.8.9.2.)**

Sets the flowrate value (defined in Flowrate Units (2.15.3.7.) (Page 238)) at which the High Flowrate Alarm will activate.

Values	Range: <b>0.000</b> to <b>99999.000</b>
	Default: <b>0.000</b>

**High Flowrate Value OFF (2.8.9.3.)**

Sets the flowrate value (defined in Flowrate Units (2.15.3.7.) (Page 238)) at which the High Flowrate Alarm will de-activate.

Values	Range: <b>0.000</b> to <b>99999.000</b>
	Default: <b>0.000</b>



**Assigned Relay (2.8.9.4.)**

Determines which relay (if any) will be activated when the High Flowrate Alarm activates.

Options	*	NO RELAY
		RELAY 1
		RELAY 2
		RELAY 3

**Alarm State (2.8.9.5.)**

Read only. Used to view the current state of the High Flowrate Alarm.

Options	ACTIVE
	INACTIVE

**9.2.8.10 Low Flowrate Alarm (2.8.10.)**

Available only on LUT440 (OCM model).

Reported when the OCM flowrate is within a user-defined range (see Low Flowrate Value ON (2.8.10.2.) (Page 209) and Low Flowrate Value OFF (2.8.10.3.) (Page 209)).

**Enable (2.8.10.1.)**

Enables/disables Low Flowrate Alarm.

Options		ENABLED
	*	DISABLED

**Low Flowrate Value ON (2.8.10.2.)**

Sets the flowrate value (defined in Flowrate Units (2.15.3.7.) (Page 238)) at which the Low Flowrate Alarm will activate.

Values	Range: <b>0.000</b> to <b>99999.000</b>
	Default: <b>0.000</b>

**Low Flowrate Value OFF (2.8.10.3.)**

Sets the flowrate value (defined in Flowrate Units (2.15.3.7.) (Page 238)) at which the Low Flowrate Alarm will de-activate.

Values	Range: <b>0.000</b> to <b>99999.000</b>
	Default: <b>0.000</b>

### Assigned Relay (2.8.10.4.)

Determines which relay (if any) will be activated when the Low Flowrate Alarm activates.

Options	*	NO RELAY
		RELAY 1
		RELAY 2
		RELAY 3

### Alarm State (2.8.10.5.)

Read only. Used to view the current state of the Low Flowrate Alarm.

Options	ACTIVE
	INACTIVE

### 9.2.8.11 Relay Logic (2.8.11.)

Relay contact operation is NORMALLY CLOSED for alarms and NORMALLY OPEN for controls.

By default an alarm contact is **Normally Closed**. When an alarm activates, the corresponding relay coil is de-energized. By setting this parameter to **Normally Open**, the relay coil will be energized when an alarm assigned to the relay activates.

#### Relay 1 Logic (2.8.11.1.)

Use to change the behaviour of Relay 1 when assigned to an alarm.

Options		NORMALLY OPEN
	*	NORMALLY CLOSED

#### Relay 2 Logic (2.8.11.2.)

Use to change the behaviour of Relay 2 when assigned to an alarm.

Options		NORMALLY OPEN
	*	NORMALLY CLOSED

#### Relay 3 Logic (2.8.11.3.)

Use to change the behaviour of Relay 3 when assigned to an alarm.

Options		NORMALLY OPEN
	*	NORMALLY CLOSED

**9.2.8.12 Time To Spill (2.8.12.)**

Used to predict when an overflow (spill) condition may occur. This feature works in conjunction with the High Level Alarm (2.8.1.) (Page 200).

**Level To Spill (2.8.12.1.)**

Value (defined in Units (2.1.1.) (Page 172)) representing material level at which a spill will occur.

Options	-999999.000 to 999999.000
	Default: 0.000

This value must be greater than high level alarm ON setpoint [High Level Value ON (2.8.1.2) (Page 200) ].

**Minutes Left To Spill (2.8.12.2.)**

Read only. Calculated value representing minutes remaining before a spill will occur.

Enter the level at which a spill condition will occur in Level To Spill (2.8.12.1.) (Page 211). When the High Level Alarm is tripped, the estimated time to spill is displayed in 2.8.12.2.Minutes Left To Spill. The estimated time is calculated by the LUT400 based on the material level and the rate of change of the material level. If the High Level alarm is not tripped, or the material level is falling, then the estimated time to spill will display as zero.

**9.2.9 Discrete Inputs (2.9.)**

Discrete inputs are used to trigger or alter the way SITRANS LUT400 controls devices such as pumps and alarms. Discrete inputs can be used for the following:

- as a backup level override
- allowing the device to be more flexible by interlocking control functions with external conditions.

For more detail see Discrete Inputs (Page 91).

**Note**

Default settings in the parameter tables are indicated with an asterisk (\*) unless explicitly stated.

**9.2.9.1 Backup Level Override (2.9.1)**

Use this feature to override the material reading by a discrete input such as a contacting point device. The material reading will be fixed at the programmed switch level until the discrete input is released. The LUT400 makes decisions based on the override values.

## 9.2 Setup (2.)

**Enable (2.9.1.1)**

Enables/disables the Backup Level Override function.

Options		ENABLED
	*	DISABLED

**Level Override Value (2.9.1.2)**

This value is substituted for the current reading when the selected discrete input is enabled and ON.

Values	Range: <b>0.000</b> to <b>60.000</b>
	Default: 0.000

Value is defined in current Units (2.1.1.) (Page 172), and is valid only for level (and head when Sensor Mode (2.1.2.) (Page 173) set to Flow). (Volume is calculated based on the Backup level.)

**Discrete Input Number (2.9.1.3)**

Sets the discrete input to act as the source for a level reading override when enabled.

Options	*	DISCRETE INPUT 1
		DISCRETE INPUT 2

**9.2.9.2 Discrete Input Logic (2.9.2)**

Use the following parameters to configure the discrete input itself.

Normal state is standard operation, with the SITRANS LUT400 sensing the material level and controlling the pumps, and no faults or alarms present. The discrete input contacts are either NORMALLY OPEN or NORMALLY CLOSED when the system state is normal.

Discrete Input Logic	Terminal Block	Discrete Input Scaled State
Normally Open	Voltage applied	ON
	No voltage applied	OFF
Normally Closed	Voltage applied	OFF
	No voltage applied	ON

For example:

When discrete input logic is set to Normally Open and discrete input has no voltage applied on the terminal block, the discrete input will be inactive (OFF).

**Discrete Input 1 Logic (2.9.2.1)**

Use to change the behaviour of the Discrete Input 1.

Options	*	NORMALLY OPEN
		NORMALLY CLOSED

**Discrete Input 1 Scaled State (2.9.2.2)**

Read only. Indicates the current state of Discrete Input 1.

Options		ON
	*	OFF

**Discrete Input 2 Logic (2.9.2.3)**

Use to change the behaviour of the Discrete Input 2.

Options	*	NORMALLY OPEN
		NORMALLY CLOSED

**Discrete Input 2 Scaled State (2.9.2.4)**

Read only. Indicates the current state of Discrete Input 2.

Options		ON
	*	OFF

**9.2.9.3 Pump Interlock (2.9.3.)**

Available only on LUT430 (Pump and Flow model), and LUT440 (OCM model). Discrete inputs allow you to supply pump information to the SITRANS LUT400 so that it can modify pump algorithms. The following parameters are used to program actions that should take place when a pump is determined to be in a failed state. For example, a pump interlock can be used to ensure that any pump reporting a failure is removed from the pumping rotation.

**Enable Pump 1 (2.9.3.1)**

Enables/disables the pump start interlock. If ON, then Pump 1 will not start if the corresponding discrete input [Pump 1 Discrete Input (2.9.3.2) (Page 213)] is active.

Options		ENABLED
	*	DISABLED

**Pump 1 Discrete Input (2.9.3.2)**

Sets the discrete input to use for pump start interlock on Pump 1.

Options	*	DISCRETE INPUT 1
		DISCRETE INPUT 2

9.2 Setup (2.)

**Enable Pump 2 (2.9.3.3)**

Enables/disables the pump start interlock. If ON, then Pump 2 will not start if the corresponding discrete input [Pump 2 Discrete Input (2.9.3.4) (Page 214)] is active.

Options		ENABLED
	*	DISABLED

**Pump 2 Discrete Input (2.9.3.4)**

Sets the discrete input to use for pump start interlock on Pump 2.

Options	*	DISCRETE INPUT 1
		DISCRETE INPUT 2

**9.2.10 Data Logging (2.10.)**

Use data logging to keep track of a parameter value on regular intervals or when an event is triggered. Up to 3 data logs can be configured, and collectively the logs can hold approximately 24,000 entries. [To view these data logs, see View Logs (3.2.6.) (Page 247).]

**9.2.10.1 Logging Mode (2.10.1.)**

Set the behaviour of the data log when full. If First in First out, when new entries are added, the oldest entry is deleted. If Fill and Stop, when new entries are added, the logging system stops.

Options		FIRST IN FIRST OUT
	*	FILL AND STOP

**9.2.10.2 Process Value Log (2.10.2.)**

**Enable (2.10.2.1.)**

Enables/disables Process Value (PV) Logging.

Options		ENABLED
	*	DISABLED

**Process Values Log Rate (2.10.2.2.)**

Sets Process Value (PV) Logging rate in minutes.

Values	Range: 1 to 1440
	Default: 1

**9.2.10.3 Alarm Log (2.10.3.)****Enable (2.10.3.1.)**

Enables/disables Alarm Logging.

Options		ENABLED
	*	DISABLED

**9.2.10.4 Flow Log (2.10.4.)**

Available only on LUT430 (Pump and Flow model), and LUT440 (OCM model).

**Note**

Default settings in the parameter tables are indicated with an asterisk (\*) unless explicitly stated.

**Flow Log Mode (2.10.4.1.)**

Menu number 2.10.4.1. visible on LUT430 (Pump and Flow model).

OR

**Flow Log Mode (2.10.4.2.)**

Menu number 2.10.4.2. visible on LUT440 (OCM model).

Sets flow log mode.

Options	*	OFF
		FIXED RATE
		VARIABLE PERCENTAGE MAX FLOW / MIN <sup>1</sup>
		VARIABLE PERCENTAGE MAX FLOW <sup>1</sup>
		VARIABLE PERCENTAGE MAX HEAD <sup>1</sup>

<sup>1</sup>) Option available only for LUT440.

**Standard Flow Log Interval (2.10.4.3.)**

Sets standard flow log interval in minutes, when Flow Log Mode (2.10.4.1.) (Page 215) set to a fixed or variable rate.

Values	Range: 1 to 1440
	Default: 1

9.2 Setup (2.)

**Standard Flow Log Setpoint (2.10.4.4.)**

Sets standard flow setpoint as a percent based on flow log mode, when Flow Log Mode (2.10.4.1.) (Page 215) set to a variable rate.

Values	Range: <b>0.000</b> to <b>110.000</b>
	Default: 0.000

**Rapid Flow Log Interval (2.10.4.5.)**

Sets rapid flow log interval in minutes, when Flow Log Mode (2.10.4.1.) (Page 215) set to a variable rate.

Values	Range: <b>1</b> to <b>1440</b>
	Default: 1

**Rapid Flow Log Setpoint (2.10.4.6.)**

Sets rapid flow setpoint as a percent based on flow logger mode, when Flow Log Mode (2.10.4.1.) (Page 215) set to a variable rate.

Values	Range: <b>0.000</b> to <b>110.000</b>
	Default: 0.000

**9.2.10.5 Delete Logs (2.10.5.)**

Select YES to permanently delete all data logs in the LUT400.

Options	NO
	YES

**9.2.11 Other Control (2.11.)**

---

**Note**

Default settings in the parameter tables are indicated with an asterisk (\*) unless explicitly stated.

---

**9.2.11.1 Elapsed Time Relay (2.11.1.)**

This function drives a relay based on an interval and duration of time. The relay toggles on and off at a rate set by the parameters below. (This relay is not affected by LOE, faults, alarms, or any other condition within the device.)



**Enable (2.11.1.1.)**

Enables/disables elapsed time relay control.

Options		ENABLED
	*	DISABLED

**Interval (2.11.1.2.)**

The interval in minutes from the activation of the relay until the next activation.

Values	Range: <b>0.1 to 99999</b> <sup>1</sup>
	Default: 60.0

<sup>1)</sup> Fractional values are allowed, such as 0.5 for 30 seconds

This value must be greater than the Relay Duration (2.11.1.3.) (Page 217) or the relay will never reset. The first activation occurs when the device is powered on.

**Relay Duration (2.11.1.3.)**

The time in seconds from one change of state in the relay to the next.

Values	Range: <b>1 to 99999</b>
	Default: 10

This value must be less than the Interval (2.11.1.2.) (Page 217) or the relay will never reset.

**Assigned Relay (2.11.1.4.)**

Determines the relay assigned to elapsed time control.

Options	*	RELAY 1
		RELAY 2
		RELAY 3

**Relay Logic (2.11.1.5.)**

Use to change the behaviour of the relay assigned to elapsed time control.

Options	*	NORMALLY OPEN
		NORMALLY CLOSED

Relay contact operation is NORMALLY CLOSED for alarms and NORMALLY OPEN for controls.

By default a control contact is **Normally Open**. For Relay Duration (2.11.1.3.) (Page 217) the corresponding relay coil is energized. By setting this parameter to **Normally Closed**, the relay coil will be de-energized for the duration phase.

9.2 Setup (2.)

**9.2.11.2 Time of Day Relay (2.11.2)**

This function drives a relay based on time of day. The relay toggles on and off at a rate set by the parameters below. This relay is not affected by LOE, faults, alarms, or any other condition within the device.

**Enable (2.11.2.1.)**

Enables/disables elapsed time of day relay control.

Options		ENABLED
	*	DISABLED

**Activation Time (2.11.2.2.)**

Sets time of day, using a 24-hour clock, at which the relay should activate.

Values	Range: <b>00:00</b> to <b>23:59</b>
	Format: HH:MM (24 hour format, for example for 5:30 pm, set parameter to <b>17:30</b> )
	Default: 00:00

For instructions on how to edit parameters with a string editor, see **Using the string editor** in Date and Time (2.14.) (Page 232).

**Relay Duration (2.11.2.3.)**

The time in seconds from one change of state in the relay to the next.

Values	Range: <b>1</b> to <b>99999</b>
	Default: 10

**Assigned Relay (2.11.2.4.)**

Determines the relay assigned to time of day control.

Options	*	RELAY 1
		RELAY 2
		RELAY 3

**Relay Logic (2.11.2.5.)**

Use to change the behaviour of the relay assigned to time of day control.

Options	*	NORMALLY OPEN
		NORMALLY CLOSED

Relay contact operation is NORMALLY CLOSED for alarms and NORMALLY OPEN for controls.

By default a control contact is **Normally Open**. For Relay Duration (2.11.2.3.) (Page 218) the corresponding relay coil is energized. By setting this parameter to **Normally Closed**, the relay coil will be de-energized for the duration phase.

**9.2.11.3 External Totalizer (2.11.3)**

Available only on LUT430 (Pump and Flow model), and LUT440 (OCM model).

This function tracks the volume of material that passes through a system. The external totalizer controls a relay to signal an external totalizing device. The relay toggles on and off at a rate set by the parameters below. (For details on relay behaviour under fail-safe conditions, see Miscellaneous relays (Page 88).)

**Note**

Default settings in the parameter tables are indicated with an asterisk (\*) unless explicitly stated.

**Enable (2.11.3.1.)**

Enables/disables external totalizer relay control.

Options		ENABLED
	*	DISABLED

**Multiplier (2.11.3.2.)**

Use to scale the external totalizer up or down as required.

Values	Range: <b>0.0000001</b> to <b>99999.000</b>
	Default: 1.000

This allows the totalizer relay to click for different values of volume.

**Example:**

To click once every 4310 units, set 2.11.3.2. Multiplier to 4310.

**Relay Duration (2.11.3.3.)**

The time in seconds from one change of state in the relay to the next.

Values	Range: <b>0.1</b> to <b>1024.0</b>
	Default: 0.2

**Assigned Relay (2.11.3.4.)**

Determines the relay assigned to external totalizer control.

Options	*	RELAY 1
		RELAY 2
		RELAY 3

**Relay Logic (2.11.3.5.)**

Use to change the behaviour of the relay assigned to external totalizer control.

Options	*	NORMALLY OPEN
		NORMALLY CLOSED

Relay contact operation is NORMALLY CLOSED for alarms and NORMALLY OPEN for controls.

By default a control contact is **Normally Open**. For Relay Duration (2.11.3.3.) (Page 220) the corresponding relay coil is energized. By setting this parameter to **Normally Closed**, the relay coil will be de-energized for the duration phase.

**9.2.11.4 External Sampler (2.11.4.)**

Available only on LUT430 (Pump and Flow model), and LUT440 (OCM model).

This function uses a relay to signal a flow sampling device when a certain volume of material has passed through a system (set by the Multiplier), or after a defined period of time (set by the Interval). The relay toggles on and off at a rate set by the parameters below. (For details on relay behaviour under fail-safe conditions, see Miscellaneous relays (Page 88).)

**Note**

Default settings in the parameter tables are indicated with an asterisk (\*) unless explicitly stated.

**Enable (2.11.4.1.)**

Enables/disables flow sampler relay control.

Options		ENABLED
	*	DISABLED

**Multiplier (2.11.4.2.)**

Use to scale the external sampler up or down as required.

Values	Range: <b>0.0000001</b> to <b>99999.000</b>
	Default: 1.000

This allows the totalizer relay to click for different values of volume.

**Example:**

To click once every 4310 units, set 2.11.4.2. Multiplier to 4310.

**Interval (2.11.4.3.)**

The time in hours from the activation of the relay until the next activation.

Values	Range: <b>0.1</b> to <b>99999.00</b>
	Default: 1.00

Set the time to activate the relay during low-flow conditions.

**Relay Duration (2.11.4.4.)**

The time in seconds from one change of state in the relay to the next.

Values	Range: <b>0.1</b> to <b>1024.0</b>
	Default: 0.2

This value must be less than the Interval (2.11.4.3.) (Page 221) or the relay will never reset.

**Assigned Relay (2.11.4.5.)**

Determines the relay assigned to flow sampler control.

Options	*	RELAY 1
		RELAY 2
		RELAY 3

**Relay Logic (2.11.4.6.)**

Use to change the behaviour of the relay assigned to flow sampler control.

Options	*	NORMALLY OPEN
		NORMALLY CLOSED

Relay contact operation is NORMALLY CLOSED for alarms and NORMALLY OPEN for controls.

By default a control contact is **Normally Open**. For Interval (2.11.4.3.) (Page 221) the corresponding relay coil is energized. By setting this parameter to **Normally Closed**, the relay coil will be de-energized for the duration phase.

## 9.2.12 Signal Processing (2.12.)

### Note

Default settings in the parameter tables are indicated with an asterisk (\*) unless explicitly stated.

### 9.2.12.1 Temperature and Velocity (2.12.1.)

#### Sound Velocity (2.12.1.1.)

The value adjusted based on the Sound Velocity at 20 degrees C (2.12.1.5.) (Page 223) vs. Process Temperature (2.12.1.2.) (Page 222) characteristics of air.

Values	Range: <b>125.000</b> to <b>20000.000</b> m/s
	Default: 344.130 m/s

Alternatively, enter the current sound velocity (if known), or perform an Auto Sound Velocity (2.12.1.6.) (Page 223). Value is always reported in m/s.

#### Process Temperature (2.12.1.2.)

View the transducer temperature in °C.

If Temperature Source (2.12.1.3.) (Page 222) is set to any value other than Fixed Temperature (2.12.1.4.) (Page 223), the value displayed is the temperature measured. If Temperature Source is set to **Temp Fixed**, the Fixed Temperature (2.12.1.4.) (Page 223) value is displayed.

#### Temperature Source (2.12.1.3.)

Source of the temperature reading used to adjust the speed of sound.

Options	*	TRANSDUCER
		FIXED TEMPERATURE
		EXTERNAL TS-3
		AVERAGE OF SENSORS (Transducer and TS-3)

With this default, the SITRANS LUT400 uses the transducer's internal temperature sensor (standard in all Siemens EchoMax Transducers).

If the transducer does not have an internal temperature sensor, Fixed Temperature value, or an External TS-3 temperature sensor can be used.

If the acoustic beam atmosphere temperature varies with distance from the transducer, connect a TS-3 Temperature Sensor and Ultrasonic/ Temperature Transducer, and select Average of Sensors (Transducer and TS-3).

In gasses other than air, the temperature variation may not correspond with the speed of sound variation. In these cases, turn off the temperature sensor, select value Fixed Temperature, and set a fixed temperature [see Fixed Temperature (2.12.1.4.) (Page 223)].

If Ultrasonic/Temperature Transducer, TS-3 Temperature Sensor, or Average of Sensors value is selected, faults on the temperature sensors will be displayed if the sensor appears open or short.

When a transducer temperature sensor fault occurs, Temperature Source can be set to FIXED. This allows the device to continue measuring (and no cable fault will display), until the transducer is replaced. Once replaced, set Temperature Source back to its original setting.

### Fixed Temperature (2.12.1.4.)

Use this feature if a temperature sensing device is not used.

Values	Range: -100.0 to +150.0 °C
	Default: +20.0 °C

Enter the temperature (in °C) of the atmosphere within the transducer acoustic beam. If the temperature varies with distance from the transducer, enter the average temperature.

### Sound Velocity at 20 degrees C (2.12.1.5.)

This value is used to automatically calculate sound velocity.

Values	Range: 125.000 to 20000.000 m/s
	Default: 344.13 m/s

If the acoustic beam atmosphere sound velocity at 20°C (68 °F) is known, and the sound velocity vs. temperature characteristics are similar to that of air (344.1 m/s), enter the sound velocity. Units displayed in meters per second (m/s).

### Auto Sound Velocity (2.12.1.6.)

#### Note

Auto Sound Velocity supports adjustments to distance value only.

Adjusts the speed of sound and changes the distance measurement calculations. Defined in Units (2.1.1.) (Page 172).

Values	Range: 0.000 to 60.000
--------	------------------------

#### Condition for use of this feature:

- The acoustic beam atmosphere is other than air
- The acoustic beam atmosphere temperature is unknown
- The Reading accuracy is acceptable at higher material levels only.

For best results, calibrate with the level at a known value near Low Calibration Point.

9.2 Setup (2.)

**Using Auto Sound Velocity:**

Start with a steady distance at a known high distance value (high distance value equates to a low level value).

1. Review the distance measurement via LUI for approximately 30 seconds to verify repeatability.
2. Measure the actual distance (for example, with a tape measure).
3. Enter the actual distance, defined in Units (2.1.1.) (Page 172).

Repeat this procedure if the atmosphere type, concentration, or temperature conditions are different from when the last sound velocity calibration was performed.

---

**Note**

In gasses other than air, the temperature variation may not correspond with the speed of sound variation. Turn off temperature sensor and use a fixed temperature.

---

**9.2.12.2 Echo Select (2.12.2.)**

**Algorithm (2.12.2.1.)**

Selects the algorithm to be applied to the echo profile to extract the true echo.

<b>Options</b>		TF TRUE FIRST	True First echo
		TR TRACKER	TRacker
		L LARGEST ECHO	Largest echo
	*	BLF BEST F-L	Best of <b>F</b> irst and <b>L</b> argest echo
		ALF AREA LARGEST FIRST	Area, <b>L</b> argest and <b>F</b> irst

For more details, see Algorithm (Page 296).

**Echo Threshold (2.12.2.2.)**

Sets the minimum echo confidence that the echo must meet in order to prevent a Loss of Echo condition and the expiration of the Fail-safe (LOE) timer. When Confidence (3.2.9.2.) (Page 249) exceeds Echo Threshold (2.12.2.2.), the echo is accepted as a valid echo and is evaluated.

<b>Values</b>	Range: <b>-20 to 128</b>
	Default: 5

Use this feature when an incorrect material level is reported.



**Reform Echo (2.12.2.3.)**

Smooth jagged peaks in the echo profile.

<b>Values</b>	Range: <b>0</b> to <b>50</b> intervals <sup>1</sup> (greater = wider)
	Default: 0

<sup>1)</sup> one interval = span of 24.5 micro seconds

Use this feature when monitoring solids if the reported level fluctuates slightly though the monitored surface is still. Enter the amount (in ms) of Echo Profile smoothing required. When a value is keyed in, the nearest acceptable value is entered.

**Narrow Echo Filter (2.12.2.4.)**

Filters out echoes of a specific width.

<b>Values</b>	Range: <b>0</b> to <b>14</b> intervals <sup>1</sup> (greater = wider)
	Default: 2

<sup>1)</sup> one interval = span of 24.5 micro seconds

Use this for transducer acoustic beam interference (e.g. ladder rungs). Enter the width of false echoes (in groups of 25 ms), to be removed from the Echo Profile. [For example, select value of 3 to remove 75 ms (3 x 25 ms) of false echoes from the profile.]

When a value is keyed in, the nearest acceptable value is entered.

**Submergence Detection (2.12.2.5.)**

Enables/disables submergence detection.

<b>Values</b>		Enabled
	*	Disabled

(Submergence Detection Shield must first be installed on transducer.) When this parameter is enabled and the transducer becomes submerged:

- fault code 26 is displayed (see General Fault Codes (Page 273)),
- mA output immediately advances to Minimum mA Limit (2.5.5.) (Page 183) or Maximum mA Limit (2.5.6.) (Page 183), as defined by the application,
- DISTANCE is set to zero (corresponding to a high level),
- pumps and alarms operate normally (according to level), therefore they remain ON (or activate if not already ON).

The submergence condition remains in effect until the transducer is no longer submerged. A valid echo must then be detected before the LOE Timer expires or the device will enter fail-safe condition (see Fail-Safe (2.4.) (Page 179)).

**Short Shot Enabled (2.12.2.6.)**

Enables/disables short shot.

Options	*	ENABLED
		DISABLED

**Short Echo Threshold (2.12.2.7.)**

Determines which echoes are evaluated by software

Values	Range: 0 ... 99
	Default: 10

**Short Shot Range (2.12.2.8.)**

Enter the maximum distance in Units (Page 172) to be measured using short shot echoes.

Values	Range: 0 ... 2 m or equivalent, depending on Units (Page 172)
	Preset: 1.000

This feature is automatically altered when Transducer (Page 174) is altered.

**Short Shot Floor (2.12.2.9.)**

Enter the minimum echo strength, in dB above 1 uV, derived from a short shot to be considered for evaluation.

Values	Range: 0 ... 100
	Preset: 50

### 9.2.12.3 TVT Setup (2.12.3.)

---

#### Note

Default settings in the parameter tables are indicated with an asterisk (\*) unless explicitly stated.

---

#### Auto False Echo Suppression (2.12.3.1.)

Used together with Shaper Mode and Auto False Echo Suppression (Page 297) to screen out false echoes in a vessel with known obstructions. A 'learned TVT' (time varying threshold) replaces the default TVT over a specified range. See Shaper Mode and Auto False Echo Suppression (Page 297) for a more detailed explanation.

---

#### Note

- Make sure material level is below all known obstructions when Auto False Echo Suppression is used to learn the echo profile. (An empty or almost empty vessel is recommended.)
  - Note the distance to material level when Auto False Echo learns the environment. Set Auto False Echo Suppression Range to a shorter distance to avoid the material echo being screened out.
  - Set Auto False Echo Suppression and Auto False Echo Suppression Range during startup, if possible.
  - All other tuning and filter adjustments (such as Narrow Echo Filter (2.12.2.4.) (Page 225), Reform Echo (2.12.2.3.) (Page 225), Hover Level (2.12.3.3.) (Page 228), and so on.) should be completed prior to using Auto False Echo Suppression to ensure that the learned profile is representative.
- 

1. Determine Auto False Echo Suppression Range. Measure the actual distance from the sensor reference point to the material surface using a rope or tape measure.
2. Subtract 0.5 m (20") from this distance, and use the resulting value.

#### To set Auto False Echo Suppression via SIMATIC PDM:

Open the menu **Device – Echo Profile Utilities** and click on the tab **Auto False Echo Suppression**. (For more detailed instructions see Auto False Echo Suppression in LUT400 Communications manual!.)

To set Auto False Echo Suppression via the local push buttons:

Options		OFF	Default TVT will be used.
	*	ON	'Learned' TVT will be used.
		LEARN	'Learn' the TVT.

3. Navigate to Setup (2.) (Page 172) > Signal Processing (2.12.) (Page 222) > TVT Setup (2.12.3.) (Page 227) > Auto False Echo Suppression Range (2.12.3.2.) (Page 228), and enter the value calculated in step 2).

## 9.2 Setup (2.)

4. Navigate to Setup (2.) (Page 172) > Signal Processing (2.12.) (Page 222) > TVT Setup (2.12.3.) (Page 227) > Auto False Echo Suppression (2.12.3.1.), and press **RIGHT arrow** to open Edit Mode.
5. Select Learn. The device will automatically revert to On (Use Learned TVT) after a few seconds.

<sup>1</sup> Communications for SITRANS LUT400 (HART) Manual (7ML19985NE01)

### Auto False Echo Suppression Range (2.12.3.2.)

Specifies the range within which Learned TVT is used (see Auto False Echo Suppression (2.12.3.1.) (Page 227) for more detail).

Values	Range: <b>0.000</b> to <b>60.000</b> m
	Default: 1.000

1. Calculate range according to Auto False Echo Suppression (2.12.3.1.) (Page 227) steps 1 and 2.
2. Press **RIGHT arrow** to open Edit mode.
3. Enter the new value and press **RIGHT arrow** to accept it.
4. Navigate to Setup (2.) (Page 172) > Signal Processing (2.12.) (Page 222) > TVT Setup (2.12.3.) (Page 227) > Auto False Echo Suppression (2.12.3.1.) (Page 227), and set value.

### Hover Level (2.12.3.3.)

Defines how high the TVT (Time Varying Threshold) is placed above the noise floor of the echo profile, as a percentage of the difference between the peak of the largest echo in the profile and the noise floor. See Example before Auto False Echo Suppression in Shaper Mode and Auto False Echo Suppression (Page 297) for an illustration.

Values	Range: <b>0</b> to <b>100</b>
	Default: <b>40</b>

When the device is located in the center of the vessel, the TVT hover level may be lowered to increase the confidence level of the largest echo.

### Shaper Mode (2.12.3.4.)

Enables/disables the TVT shaper.

Options		ON
	*	OFF

Turn TVT Shaper Mode ON before using TVT Shaper (2.12.4.) (Page 229). Turn the TVT Shaper ON and OFF while monitoring the effect to pick up the true echo.

### 9.2.12.4 TVT Shaper (2.12.4.)

Adjusts the TVT (Time Varying Threshold) at a specified range (breakpoint on the TVT). This allows you to reshape the TVT to avoid unwanted echoes. There are 40 breakpoints arranged in 5 groups. (We recommend using SIMATIC PDM to access this feature.)

#### To use TVT shaper via SIMATIC PDM:

1. Open the menu Device – Echo Profile Utilities and click on TVT Shaper. (For more details see TVT Shaper in LUT400 Communications manual<sup>1</sup>.)

#### To use TVT shaper via local push buttons:

1. Navigate to Setup (2.) (Page 172) > Signal Processing (2.12.) (Page 222) > TVT Setup (2.12.3.) (Page 227) > Shaper Mode (2.12.3.4.) (Page 228), and select **ON**.
2. From the TVT Setup menu, **LEFT ARROW** to the Signal Processing menu, and **DOWN ARROW** to TVT Shaper. **RIGHT ARROW** to enter the TVT Shaper menu and **RIGHT ARROW** to edit Breakpoint 1-8 (2.12.4.1.) (Page 229).
3. Open TVT Breakpoint 1 enter the TVT Offset value (between –50 and 50).
4. Go to the next TVT Breakpoint and repeat steps c) and d) till all desired breakpoint values have been entered.

<sup>1</sup>) Communications for SITRANS LUT400 (HART) Manual (7ML19985NE01)

#### Breakpoint 1-8 (2.12.4.1.)

Values	Range: –50 to 50 dB
	Default: 0 dB

#### Breakpoint 9-16 (2.12.4.2.)

Values	Range: –50 to 50 dB
	Default: 0 dB

#### Breakpoint 17-24 (2.12.4.3.)

Values	Range: –50 to 50 dB
	Default: 0 dB

#### Breakpoint 25-32 (2.12.4.4.)

Values	Range: –50 to 50 dB
	Default: 0 dB

### Breakpoint 33-40 (2.12.4.5.)

Values	Range: <b>-50</b> to <b>50</b> dB
	Default: <b>0</b> dB

#### 9.2.12.5 Measured Values (2.12.5.)

Read only. Allows you to view measured values for diagnostic purposes.

**To access measured values via SIMATIC PDM:**

Open the menu **View – Process Variables**.

---

#### Note

These parameters will display the simulated value when in simulation mode (see Simulation process (Page 157)).

---

#### Level Measurement (2.12.5.1.)

The distance to monitored surface referenced from Low Calibration Point (2.2.1.) (Page 176), defined in Units (2.1.1.) (Page 172).

#### Space Measurement (2.12.5.2.)

The distance to monitored surface referenced from Units (2.1.1.) (Page 172), defined in High Calibration Point (2.2.2.) (Page 176).

#### Distance Measurement (2.12.5.3.)

The distance to monitored surface referenced from the transducer face (sensor reference point), defined in Units (2.1.1.) (Page 172).

#### Volume Measurement (2.12.5.4.)

The calculated vessel volume (calculated from level and scaled according to vessel shape) in Volume Units (2.6.2.) (Page 186).

#### Head Measurement (2.12.5.5.)

Available only on LUT430 (Pump and Flow model), and LUT440 (OCM model).

Corresponds to Head [the distance from Zero Head Offset (2.15.3.5.) (Page 237) to the monitored surface in Units (2.1.1.) (Page 172)].

#### Flow Measurement (2.12.5.6.)

Available only on LUT430 (Pump and Flow model) and LUT440 (OCM model).

The calculated flowrate, defined in Flowrate Units (2.15.3.7.) (Page 238).

## 9.2.13 Display (2.13.)

---

### Note

Default settings in the parameter tables are indicated with an asterisk (\*) unless explicitly stated.

---

### 9.2.13.1 Local Display Backlight (2.13.1.)

Time the backlight remains on.

Options		OFF
	*	ON
		TIMED (on for five minutes after key press - takes effect in Measurement View only)

Available only via LUI.

### 9.2.13.2 LCD Contrast (2.13.2.)

The factory setting is for optimum visibility at room temperature and in average light conditions. Extremes of temperature will lessen the contrast.

Values	Range: <b>0</b> (Low contrast) to <b>20</b> (High contrast)
	Default: <b>10</b>

Adjust the value to improve visibility in different temperatures and luminosity.

Available only via LUI and web browser.

### 9.2.14 Date and Time (2.14.)

Enter the current date and time using the local push buttons.

Parameter Edit mode displays a string editor.

#### Using the string editor:

1. Use **RIGHT/LEFT arrow** to select the character position in the parameter field to be edited.

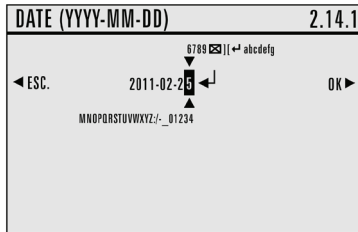

2. As each character is highlighted (selected), use the **UP/DOWN arrow** to change the character.
  - Use the **DOWN arrow** to select a character from the string **above** the parameter value.
  - Use the **UP arrow** to select a character from the string **below** the parameter value.
3. To escape without saving your changes, press **LEFT arrow** continually until **ESC** is highlighted. Press **LEFT arrow** again to escape without saving changes. Otherwise, when new parameter value is correct, press **RIGHT arrow** continually until **OK** is highlighted.
4. Press **RIGHT arrow** to accept the new value. The LCD returns to parameter view and displays the new selection. Review for accuracy.

#### Special Characters:

Character	Description	Function
:	colon	enters colon in text string
	space	enters space in text string
/	slash	enters slash in text string
-	hyphen	enters hyphen in text string
_	underscore	enters underscore in text string
⊗	'x' in box	deletes highlighted character in text string
]]	square brackets	inserts space between two characters in text string (limited to one space between characters)
↵	return arrow key	deletes characters (including currently highlighted character) to end of text string

#### 9.2.14.1 Date (2.14.1.)

Date is the current date in the format: YYYY-MM-DD.

Values	Range: 1900-01-01 to 2155-12-31
--------	---------------------------------



**9.2.14.2 Time (2.14.2.)**

Time is the current time in 24-hour format: HH:MM[:SS].

<b>Values</b>	Range: <b>00:00:00</b> to <b>23:59:59</b>
---------------	---

A value for seconds [:SS] is optional. If a value is not entered, the clock will default to 0 seconds.

**9.2.14.3 Daylight Saving (2.14.3.)**

Use the following parameters to enable and define start/end dates for daylight saving. (Start/end time of day is always 2:00am.)

**Example:**

Set the start of daylight saving to the second Sunday in February, and the end of daylight saving to the first Sunday in November:

Starting Ordinal = Second

Starting Day = Sunday

Starting Month = February

Ending Ordinal = First

Ending Day = Sunday

Ending Month = November

**Enable (2.14.3.1.)**

Enables/disables daylight saving.

<b>Options</b>		ENABLED
	*	DISABLED

**Starting Ordinal (2.14.3.2.)**

The order of the day within the month when daylight saving will begin.

<b>Options</b>		FIRST, SECOND, THIRD, FOURTH
	*	FIRST

**Starting Day (2.14.3.3.)**

The day of the week on which daylight saving will begin.

<b>Options</b>		SUNDAY, MONDAY, TUESDAY, WEDNESDAY, THURSDAY, FRIDAY, SATURDAY
	*	SUNDAY

9.2 Setup (2.)

**Starting Month (2.14.3.4.)**

The month on which daylight saving will begin.

Options		JANUARY, FEBRUARY, MARCH, APRIL, MAY, JUNE, JULY, AUGUST, SEPTEMBER, OCTOBER, NOVEMBER, DECEMBER
	*	JANUARY

**Ending Ordinal (2.14.3.5.)**

The order of the day within the month when daylight saving will end.

Options		FIRST, SECOND, THIRD, FOURTH
	*	FIRST

**Ending Day (2.14.3.6.)**

The day of the week on which daylight saving will end.

Options		SUNDAY, MONDAY, TUESDAY, WEDNESDAY, THURSDAY, FRIDAY, SATURDAY
	*	SUNDAY

**Ending Month (2.14.3.7.)**

The month on which daylight saving will end.

Options		JANUARY, FEBRUARY, MARCH, APRIL, MAY, JUNE, JULY, AUGUST, SEPTEMBER, OCTOBER, NOVEMBER, DECEMBER
	*	JANUARY

**9.2.15 Flow (2.15.)**

Available only on LUT430 (Pump and Flow model) and LUT440 (OCM model).

**Note**

Default settings in the parameter tables are indicated with an asterisk (\*) unless explicitly stated.

**9.2.15.1 Primary Measuring Device (PMD) (2.15.1.)**

The type of primary measuring device (PMD) used.

Values	*	OFF (no calculation)
		EXPONENTIAL DEVICES
		RECTANGULAR FLUME BS-3680
		ROUND NOSE HORIZONTAL CR. BS-3680

	TRAPEZOIDAL FLUME BS-3680
	U-FLUME BS-3680
	FINITE CREST WEIR BS-3680
	THIN PLATE RECT. WEIR BS-3680
	THIN PLATE V-NOTCH WEIR BS-3680
	RECT. WEIR CONTRACTED
	ROUND PIPE
	PALMER BOWLUS FLUME
	H-FLUME
	UNIVERSAL HEAD FLOW

The LUT400 is pre-programmed for common PMD flow calculations. If your PMD is not listed, use a Universal Flow calculation. See Universal calculation support (Page 149).

### 9.2.15.2 Auto Zero Head (2.15.2.)

Calibrates Zero Head Offset (2.15.3.5.) (Page 237) (defined in Units (2.1.1.) (Page 172)) based on actual head measurements.

<b>Values</b>	Range: <b>-60.000 to 60.000</b>
	Default: 0.000

Use this parameter when the reported head is consistently high or low by a fixed amount.

Before using this feature, verify the following parameters are correct:

- Low Calibration Point (2.2.1.) (Page 176)
- Process Temperature (2.12.1.2.) (Page 222)

With HEAD steady...

1. Measure the actual head (e.g. with a tape measure or solid rule)
2. Enter the actual head value

The deviation between the entered head value and the calibrated value, is stored in Zero Head Offset (2.15.3.5.) (Page 237).

### 9.2.15.3 Basic Setup (2.15.3.)

#### Method of Flow Calculation (2.15.3.1.)

Sets the method of flow calculation.

<b>Options</b>	*	ABSOLUTE
		RATIOMETRIC

Set this parameter to **Ratiometric** only if the primary measuring device (PMD) supports ratiometric calculations. (Note that Palmer Bowlus Flume and H-Flume support ratiometric calculations only.) For more details on Absolute and Ratiometric calculations, see Method of Flow Calculation (Page 306).

### Flow Exponent (2.15.3.2.)

The exponent for the flow calculation formula.

Values	Range: <b>-999.000</b> to <b>9999.000</b>
	Default: 1.550

Use this parameter if the PMD is set to Exponential devices. It creates an exponential curve with end points set by Maximum Head (2.15.3.3.) (Page 237) and Zero Head Offset (2.15.3.5.) (Page 237) and with the curve based on the specified exponent.

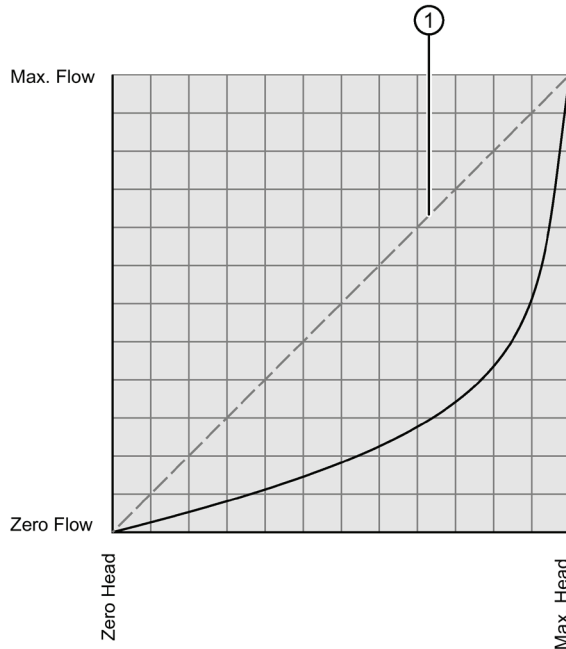

① Flow exponent

The exponential equation is:

$$Q = KH^{\text{Flow Exponent (2.15.3.2.)}}$$

Where:

Q= flow

K= constant factor

H= head

Use the exponent specified by the PMD manufacturer, if available, or relevant Open Channel Monitoring reference material.

### Maximum Head (2.15.3.3.)

The maximum level value associated with the PMD and works in conjunction with Maximum Flow at 20 mA (2.15.3.4.) (Page 237) at 20 mA for Ratiometric calculations. (Defined in Units (2.1.1.) (Page 172))

Values	Range: <b>0.000</b> to <b>60.000</b>
	Default: 60.000

This represents the highest head level supported by the Primary Measuring Device (PMD) and works in conjunction with Maximum Flow at 20 mA (2.15.3.4.) (Page 237) at 20 mA to define the highest point in the exponential curve. Use it when the PMD requires a maximum head and flow reference point. Maximum Head must be set for all Absolute and Ratiometric PMDs.

### Maximum Flow at 20 mA (2.15.3.4.)

#### Note

- The display of the measured value is limited to 7 Characters. Setting a Maximum Flow value larger than 7 characters will not display correctly.
- If measured value is larger than 7 characters, ##### will be displayed. A larger unit (Flowrate Units (2.15.3.7.) (Page 238)) should be used, or number of decimal points (Flowrate Decimal (2.15.3.6.) (Page 238)) should be reduced.

The maximum flowrate associated with Maximum Head (2.15.3.3.) (Page 237) shown in Flowrate Units (2.15.3.7.) (Page 238).

Values	Range: <b>0</b> to <b>9999999</b>
	Default: 100

This represents the flow at the highest head level supported by the Primary Measuring Device (PMD) and works in conjunction with Maximum Head (2.15.3.3.) (Page 237) to define the highest point in the exponential curve. Use it when the PMD requires a maximum head and flow reference point. Maximum Flow must be set for all Absolute and Ratiometric PMDs.

### Zero Head Offset (2.15.3.5.)

The difference (positive or negative) between Low Calibration Point and zero head (level at zero flow), defined in Units (2.1.1.) (Page 172).

Values	Range: <b>-60.000</b> to <b>60.000</b>
	Default: 0.000

This feature can be used for most weirs and some flumes (e.g. Palmer Bowlus) where the zero reference is at a higher elevation than the channel bottom.

9.2 Setup (2.)

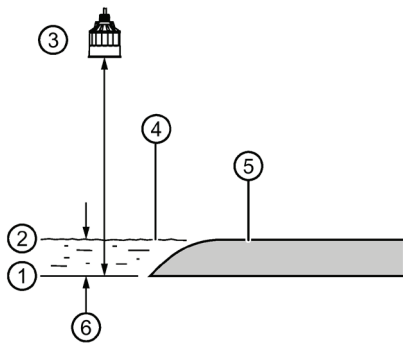

- ① Low calibration point
- ② Zero head
- ③ Transducer
- ④ Material level at zero flow
- ⑤ PMD base
- ⑥ Zero head offset

**Flowrate Decimal (2.15.3.6.)**

The maximum number of decimal places to be displayed.

<b>Options</b>	*	NO DIGITS	no digits after the decimal point
		1 DIGIT	1 digit after the decimal point
		2 DIGITS	2 digits after the decimal point
		3 DIGITS	3 digits after the decimal point

**Flowrate Units (2.15.3.7.)**

The volume units used to display total flow.

<b>Options</b>	*	L/S (Litres per second)
		L/MIN (Litres per minute)
		CUFT/S (Cubic feet per second)
		CUFT/D (Cubic feet per day)
		GAL/MIN (US Gallons per minute)
		GAL/D (US Gallons per day)
		IMPGAL/MIN (Imperial Gallons per minute)
		IMPGAL/D (Imperial Gallons per day)
		CUM/H (Cubic meters per hour)
		CUM/D (Cubic meters per day)
		MMGAL/D (Mega-gallons per day)
		USER DEFINED (units defined in User Defined Unit (2.15.3.8.) (Page 239))

**User Defined Unit (2.15.3.8.)**

Set the unit text to display for current flow when Flowrate Units (2.15.3.7.) (Page 238) set to user-defined. Limited to 16 ASCII characters.

**Note**

The text entered is simply for display purposes. No unit conversion occurs.

**Low Flow Cutoff (2.15.3.9.)**

Eliminates totalizer activity for head levels at or below the cutoff value.

<b>Values</b>	Range: <b>0.000</b> to <b>60.000</b>
	Default: 0.000

Enter the minimum head in Units (2.1.1.) (Page 172) where totalizer activity should cease.

**9.2.15.4 PMD Dimensions (2.15.4.)**

The dimensions of the Primary Measuring Device (PMD). (The dimensions of the vessel, wet well, or reservoir are only important if you require volume.)

The following table is a reference to the parameters that must be set for each PMD. Parameter definitions follow the table.

<b>Supported PMD</b>	<b>Dimensions Required</b>
<b>Exponential devices</b>	
	Flow exponent (2.15.3.2.)
	K factor (2.15.4.1.)
<b>Rectangular Flume BS-3680</b>	
	Approach width B - OCM Dimension 1 (2.15.4.5.)
	Throat width b - OCM Dimension 2 (2.15.4.6.)
	Hump height p - OCM Dimension 3 (2.15.4.7.)
	Throat length L - OCM Dimension 4 (2.15.4.8.)
<b>Round Nose Horizontal Crest Weir BS-3680</b>	
	Crest width b - OCM Dimension 1 (2.15.4.5.)
	Crest height p - OCM Dimension 2 (2.15.4.6.)
	Crest length L - OCM Dimension 3 (2.15.4.7.)
<b>Trapezoidal Flume BS-3680</b>	
	Approach width B - OCM Dimension 1 (2.15.4.5.)
	Throat width b - OCM Dimension 2 (2.15.4.6.)
	Hump height p - OCM Dimension 3 (2.15.4.7.)
	Throat length L - OCM Dimension 4 (2.15.4.8.)
<b>U-Flume BS-3680</b>	
	Approach diameter Da - OCM Dimension 1 (2.15.4.5.)
	Throat diameter D - OCM Dimension 2 (2.15.4.6.)
	Hump height p - OCM Dimension 3 (2.15.4.7.)

9.2 Setup (2.)

Supported PMD	Dimensions Required
	Throat length L - OCM Dimension 4 (2.15.4.8.)
<b>Finite Crest Weir BS-3680</b>	
	Crest width b - OCM Dimension 1 (2.15.4.5.)
	Crest height p - OCM Dimension 2 (2.15.4.6.)
	Crest length L - OCM Dimension 3 (2.15.4.7.)
<b>Thin Plate Rectangular Weir BS-3680</b>	
	Approach width b - OCM Dimension 1 (2.15.4.5.)
	Crest width b - OCM Dimension 2 (2.15.4.6.)
	Crest height p - OCM Dimension 3 (2.15.4.7.)
<b>Thin plate V-notch weir BS-3680</b>	
	V-notch angle (2.15.4.2.)
<b>Rectangular Weir Contracted</b>	
	Crest width b - OCM Dimension 1 (2.15.4.5.)
<b>Round Pipe</b>	
	Pipe inside diameter D - OCM Dimension 1 (2.15.4.5.)
	Slope 2.15.4.3.)
	Roughness coefficient (2.15.4.4.)
<b>Palmer Bowlus Flume</b>	
	Maximum flume width hmax - OCM Dimension 1 (2.15.4.5.)
<b>H-Flume</b>	
	Maximum listed head hmax - OCM Dimension 1 (2.15.4.5.)
<b>Universal head flow</b>	
	Head 1 (up to 32) (2.15.5.1.1.)
	Flow 1 (up to 32) (2.15.5.1.2.)

**K Factor (2.15.4.1.)**

The constant used in the flow calculation formula for absolute calculation of an exponential device only.

<b>Values</b>	Range: <b>-999.000 to 9999.000</b>
	Default: 1.000

Use this parameter if the PMD is set to **Exponential devices**. The Constant Factor is used to create an exponential curve with end points set by Maximum Head (2.15.3.3.) (Page 237) and Zero Head Offset (2.15.3.5.) (Page 237) , and with the curve based on the specified exponent.

**V-Notch Angle (2.15.4.2.)**

The V-Notch angle used in the flow calculation formula.

<b>Values</b>	Range: <b>25.000 to 95.000</b>
	Default: 25.000

Use when PMD is set to Thin Plate V-Notch Weir.



**Slope (2.15.4.3.)**

The Flow Slope used in the flow calculation formula.

Values	Range: <b>-999.000</b> to <b>9999.000</b>
	Default: 0.000

Use when PMD is set to Trapezoidal Flume or Round Pipe.

**Roughness Coefficient (2.15.4.4.)**

The Flow Roughness Coefficient used in the flow calculation formula.

Values	Range: <b>-999.000</b> to <b>9999.000</b>
	Default: 0.000

Use when PMD is set to Round Pipe.

**OCM Dimensions 1- 4****OCM Dimension 1 (2.15.4.5.)****OCM Dimension 2 (2.15.4.6.)****OCM Dimension 3 (2.15.4.7.)****OCM Dimension 4 (2.15.4.8.)**

See table under PMD Dimensions (2.15.4.) (Page 239) to relate OCM Dimension 1-4 above to a specific dimension for each directly supported Primary Measuring Device. For PMDs that are not directly supported (Universal Head Flow), use a Universal Flow calculation. See Universal calculation support (Page 149).

For more information on PMD, see Open Channel Monitoring (OCM) (Page 123).

**9.2.15.5 Universal Head versus Flow (2.15.5.)**

In the following table, enter Head and Flow Breakpoints for universal PMDs.

Head Breakpoints: The head breakpoints for which flowrate is known, defined in Units (2.1.1.) (Page 172).

Flowrate Breakpoints: The flowrate corresponding to each Head Breakpoint entered, defined in Flowrate Units (2.15.3.7.) (Page 238).

Head Values	Range: <b>0.000</b> to <b>60.000</b>
	Default: 0.000
Flowrate Values	Range: <b>0</b> to <b>9999999</b>
	Default: 0

See Universal calculation support (Page 149) for details on how to specify universal flows.

**Entering breakpoints via SIMATIC PDM:**

See Quick Start (Flow) in the LUT400 Communications manual1.

9.2 Setup (2.)

**2.15.5.1. Table 1-8**

2.15.5.1.1. Head 1

2.15.5.1.2. Flow 1

**2.15.5.1. Table 9-16**

2.15.5.1.1. Head 9

2.15.5.1.2. Flow 9

**2.15.5.1. Table 17-24**

2.15.5.1.1. Head 17

2.15.5.1.2. Flow 17

**2.15.5.1. Table 25-32**

2.15.5.1.1. Head 25

2.15.5.1.2. Flow 25

**9.2.16 Totalizers (2.16.)**

Available only on LUT430 (Pump and Flow model) and LUT440 (OCM model).

---

**Note**

Default settings in the parameter tables are indicated with an asterisk (\*) unless explicitly stated.

---

**9.2.16.1 Daily Totalizer (2.16.1.)**

Read only. Current daily totalizer value. (Automatically resets daily and can be reset by user.)

Values	Range: <b>0.00</b> to <b>999999999</b>
	Default: 0.00

**9.2.16.2 Running Totalizer (2.16.2.)**

Read only. Current running totalizer value. (Reset only by user.)

Values	Range: <b>0.00</b> to <b>999999999</b>
	Default: 0.00

**9.2.16.3 Totalizer Decimal Position (2.16.3.)**

Sets the maximum number of decimal places to be displayed.

Options		NO DIGITS	no digits after the decimal point
		1 DIGIT	1 digit after the decimal point
	*	2 DIGITS	2 digit after the decimal point
		3 DIGITS	3 digit after the decimal point

**9.2.16.4 Totalizer Multiplier (2.16.4.)**

Use this feature if the LCD Total increments by an amount that is too large (or too small)..

Options		.001
		.01
		.1
	*	1
		10
		100
		1000
		10,000
		100,000
		1,000,000
	10,000,000	

Enter the factor (powers of 10 only) by which actual flow is divided, prior to display on LCD. Use a value such that the eight-digit totalizer doesn't roll over between readings.

**Example:** For an LCD Total display in 1000s of flow units, enter 1000.

**9.2.16.5 Reset Daily Totalizer (2.16.5.)**

Select **YES** to reset daily totalizer value to zero.

Options	*	NO
		YES

**9.2.16.6 Reset Running Totalizer (2.16.6.)**

Select **YES** to reset running totalizer value to zero.

Options	*	NO
		YES

## 9.3 Maintenance and Diagnostics (3.)

---

### Note

Default settings in the parameter tables are indicated with an asterisk (\*) unless explicitly stated.

---

### 9.3.1 Identification (3.1.)

To edit parameters with a string editor (3.1.1. to 3.1.5.), see Using the string editor: on Date and Time (2.14.) (Page 232).

#### 9.3.1.1 TAG (3.1.1.)

Text that can be used in any way. A recommended use is as a unique label for a field device in a plant. Limited to 32 alphanumeric characters (8 characters via HART). Appears in top left corner of display in measurement mode (see The LCD Display (Page 52)).

#### 9.3.1.2 Long TAG (3.1.2.)

Text that can be used in any way. A recommended use is as a unique label for a field device in a plant. Limited to 32 alphanumeric characters.

#### 9.3.1.3 Descriptor (3.1.3.)

Text that can be used in any way. Limited to 32 ASCII characters (16 ASCII characters via HART). No specific recommended use.

#### 9.3.1.4 Message (3.1.4.)

Text that can be used in any way. Limited to 32 ASCII characters. No specific recommended use.

#### 9.3.1.5 Installation Date (3.1.5.)

Date the device was first commissioned (YYYY-MM-DD).

##### Manufacturer

Read only. The device manufacturer (for example: Siemens).

##### Product Name

Read only. Identifies the product by name (for example: SITRANS LUT400).

**9.3.1.6 Product (3.1.6.)**

Read only. Identifies the product by name and capability:

SITRANS LUT420 (Level)

SITRANS LUT430 (Pump and Flow)

SITRANS LUT440 (OCM)

**9.3.1.7 Order No. (Order Number in PDM) (3.1.7.)**

Read only. Order number for the current device configuration (for example: 7ML5050-OCA10-1DA0).

**9.3.1.8 Serial Number (3.1.8.)**

Read only. Unique factory set serial number of the device.

**9.3.1.9 Final Assembly Number (3.1.9.)**

Integer used to identify the device on site, e.g. enter '2' to denote second SITRANS LUT400 in application.

**9.3.1.10 Hardware Revision (3.1.10.)**

Read only. Corresponds to the electronics hardware of the Field Device.

**9.3.1.11 Firmware Revision (3.1.11.)**

Read only. Corresponds to the software or firmware that is embedded in the Field Device.

**9.3.1.12 Loader Revision (3.1.12.)**

Read only. Corresponds to the software used to update the Field Device.

**EDD Version**

Read only. Corresponds to the Electronics Device Description (EDD) installed with the device.

**9.3.1.13 Manufacture Date (Date of Manufacturing in PDM) (3.1.13.)**

The date of manufacture of the SITRANS LUT400 (YYYY-MM-DD).

**9.3.1.14 Order Option (3.1.14.)**

Read only. Displays the device type: Standard or NAMUR 43-compliant.

## 9.3.2 Diagnostics (3.2.)

---

### Note

Default settings in the parameter tables are indicated with an asterisk (\*) unless explicitly stated.

---

### 9.3.2.1 Echo Profile (3.2.1.)

Allows you to request the current echo profile either locally via the local push buttons, or remotely via SIMATIC PDM.

#### To request a profile via the local push buttons:

1. In PROGRAM mode, navigate to MAIN MENU > DIAGNOSTICS (3) > ECHO PROFILE (3.1)
2. Press RIGHT arrow to request a profile.

---

### Note

An Echo Profile (3.2.1.) cannot be requested from LUI when:

- Transducer Enable (3.3.1.) (Page 250) is set to DISABLED, or when
  - Transducer (2.1.6.) (Page 174) is set to NO TRANSDUCER. In either case, the local push button will not operate.
- 

For more detail see Requesting an Echo Profile (Page 78).

For more details on how to interpret an Echo Profile, see Echo Processing (Page 295).

#### To request a profile via SIMATIC PDM:

1. Open the menu Device – Echo Profile Utilities. (For more details see Echo Profile Utilities in LUT400 Communications manual<sup>1</sup>.)

<sup>1</sup>) Communications for SITRANS LUT400 (HART) Manual (7ML19985NE01)

### 9.3.2.2 Trend (3.2.2.)

Read only. Display of level trends. Captures last 3000 PV values (logged at five minute intervals) in percentage of range (defined in Units (2.1.1.) (Page 172)). For more information, see Trends (Page 153).

### 9.3.2.3 Master Reset (3.2.3.)

---

#### Note

Following a reset to Factory Defaults, complete reprogramming is required.

---

Resets all parameter to factory defaults, with the following exceptions:

- Tag, Long Tag, Description, Message, Assembly Number
- Device Address (4.1.) (Page 264) and Language (6.) (Page 266) remain unchanged
- Write Protection (5.1.) (Page 265) value is not reset
- Auto False Echo Suppression (2.12.3.1.) (Page 227) learned TVT is not lost
- Shaper Mode (2.12.3.4.) (Page 228), and breakpoints for TVT Shaper (2.12.4.) (Page 229) are not lost
- Totalizers (2.7.3.) (Page 198) values are not reset
- Date (2.14.1.) (Page 232) and Time (2.14.2.) (Page 233) values are not reset

Options	*	DO NOTHING (Return to previous menu)
		FACTORY DEFAULTS

To perform a reset to factory defaults via SIMATIC PDM, open the menu Device – Master Reset.

### 9.3.2.4 Power-on Resets (3.2.4.)

The number of power cycles that have occurred since manufacture.

In SIMATIC PDM, open the menu Device – Wear.

### 9.3.2.5 Power-on Time (3.2.5.)

Displays the number of days the device has been powered on since manufacture.

In SIMATIC PDM, open the menu Device – Wear.

### 9.3.2.6 View Logs (3.2.6.)

View various log types with entries (to a collective maximum of approximately 24,000) listed by day. For a list of field names that coincide with the comma delimited log file on the PC, see Data Logging (Page 307).

---

#### Note

To clear entries when log memory becomes full, see Delete Logs (2.10.5.) (Page 216).

---

**Alarms (3.2.6.1.)**

History of alarms. Displays type of alarm, value at which alarm triggered, state of alarm.

**OCM (3.2.6.2.)**

Flow logs. Displays head and flow values.

**Daily Totals (3.2.6.3.)**

Daily totals for both totalizers. Displays maximum and minimum values for flow and temperature, average flow, and daily totalizer (DT) and running totalizer (RT) values.

**PV (3.2.6.4.)**

Primary Variable. Displays PV type (e.g. Level), PV value and temperature.

---

**Note**

PV is controlled by the mA function (see Current Output Function (2.5.1.) (Page 180)). Therefore, the LUI operation can be changed (via Sensor Mode (2.1.2.) (Page 173)) without affecting the process being controlled.

---

**9.3.2.7 Pump Records (3.2.7.)**

Relay usage.

**Run Time Relay 2 (3.2.7.1.)**

Read or set the total running time of Relay 2 in hours.

Values	Range: 0 to 999999
--------	--------------------

**Run Time Relay 3 (3.2.7.2.)**

Read or set the total running time of Relay 3 in hours.

Values	Range: 0 to 999999
--------	--------------------

**Relay Pump 1 (3.2.7.3.)**

Read only. Relay assigned to Pump 1.

To change the relay assignment, see Relay Pump 1 (2.7.1.2) (Page 189).



**Relay Pump 2 (3.2.7.4.)**

Read only. Relay assigned to Pump 2.

To change the relay assignment, see Relay Pump 2 (2.7.1.3) (Page 189).

**9.3.2.8 Temperature Peak Values (3.2.8.)**

This feature displays the high and low process temperatures in °C.

If the device is powered up without a temperature sensor connected, the default fixed temperature value 20 °C is displayed [see Fixed Temperature (2.12.1.4.) (Page 223)]. This information can help trace problems with both built in and external temperature sensors.

**Highest Value (3.2.8.1.)**

View the highest process temperature encountered, as measured by the transducer in °C.

**Lowest Value (3.2.8.2.)**

View the lowest process temperature encountered, as measured by the transducer in °C.

**9.3.2.9 Echo Quality (3.2.9.)****Figure of Merit (3.2.9.1.)**

This value measures the quality of the reported echo value: higher values represent better quality. This measure combines the noise level, quality of tracking, and signal strength. (For more details see Echo Processing (Page 295))

Values (view only)	Range: 0 to 100 %
--------------------	-------------------

**Confidence (3.2.9.2.)**

Indicates echo reliability: higher values represent better echo quality. The display shows the echo confidence of the last measurement. Echo Threshold (2.12.2.2.) (Page 224) defines the minimum criterion for echo confidence.

Values (view only)	Range: -20 to 128
--------------------	-------------------

In SIMATIC PDM, open the menu Device – Echo Profile Utilities and click on the tab Echo Profile.

### Echo Strength (3.2.9.3.)

Displays the absolute strength (in dB above 1  $\mu$ V rms) of the echo selected as the measurement echo.

Values (view only)	Range: -20 to 128 dB
--------------------	----------------------

In SIMATIC PDM, open the menu Device – Echo Profile Utilities and click on the tab Echo Profile.

### Noise Average (3.2.9.4.)

Displays the average ambient noise (in dB above 1  $\mu$ V rms) of a noise profile after each measurement.

The noise level is a combination of transient acoustic noise and electrical noise (induced into the transducer cable or receiving circuitry). See Noise Problems (Page 280).

### Noise Peak (3.2.9.5.)

Displays the peak ambient noise (in dB above 1  $\mu$ V rms) of a noise profile after each measurement.

## 9.3.3 Maintenance (3.3.)

---

### Note

Default settings in the parameter tables are indicated with an asterisk (\*) unless explicitly stated.

---

### 9.3.3.1 Transducer Enable (3.3.1.)

Enables/disables transducer from taking measurements.

Options	*	ENABLED
		DISABLED

Set parameter to Disabled to stop transducer from measuring while calibration or maintenance work is performed. Set to Enabled to restart measurements after calibration or maintenance complete.

---

### Note

- An Echo Profile (3.2.1.) (Page 246) cannot be requested from LUI when Transducer Enable (3.3.1.) is set to DISABLED. The local push button will not operate.
  - When Transducer Enable (3.3.1.) is set to DISABLED, the LOE fault will display immediately.
  - If Transducer Enable (3.3.1.) is set to DISABLED and power to the device is turned off, Transducer Enable (3.3.1.) will be reset to ENABLED when power is restored.
-

### 9.3.3.2 Backup Control (3.3.2.)

LUI only. Determine source of configuration recovery file when sensor has been replaced.

Options	*	DONE	No change required (no fault displayed), or operation is complete
		FROM SENSOR	Sensor parameters will be used as is, and LUI will receive these parameters as backup.
		FROM LUI	Recovery of sensor parameters will come from LUI backup.

When sensor unit has been replaced, fault code 132 is displayed to note that LUI backup file does not match configuration file in sensor. To clear fault, set Backup Control option to location from where parameter configuration should be read; from the LUI backup file or from the new sensor.

### 9.3.3.3 Remaining Device Life (3.3.3.)

#### Note

- Four sets of parameters allow you to monitor the Device/Sensor Lifetimes and set up Maintenance/Service schedules, based on operating hours instead of a calendar-based schedule. See also Remaining Sensor Life (3.3.4.) (Page 254), Service Schedule (3.3.5.) (Page 257), and Schedule (3.3.6.) (Page 260).
- Performing a reset to Factory Defaults will reset all the Maintenance Schedule parameters to their factory defaults.
- The device operates in years. To view Remaining Device Lifetime parameters in hours or days (only via SIMATIC PDM, PACTware FDT, and AMS) see Lifetime Expected (3.3.3.1.) (Page 252).

The device tracks itself based on operating hours and monitors its predicted lifetime. You can modify the expected device lifetime, set up schedules for maintenance reminders, and acknowledge them.

The maintenance warnings and reminders are available through HART communications. This information can be integrated into an Asset Management system. For optimal use, we recommend that you use SIMATIC PCS7 Asset Management Software in conjunction with SIMATIC PDM.

#### To access these parameters via SIMATIC PDM:

- Open the menu Device – Maintenance and select the Remaining Device Lifetime tab. (For more details see Maintenance in LUT400Communications manual<sup>1</sup>.)

#### Time Units

Allows you to set the desired units.

Options <sup>2</sup>		HOURS
		DAYS
	*	YEARS

<sup>1</sup>) Communications for SITRANS LUT400 (HART) Manual (7ML19985NE01)

<sup>2</sup>) Units are selectable only via SIMATIC PDM, PACTware FDT, and AMS.

### Lifetime Expected (3.3.3.1.)

---

**Note**

The device always operates in years. Changing the Time Units affects only the parameter view of the Remaining Device Lifetime parameters in SIMATIC PDM, PACTware FDT, and AMS.

---

Allows you to override the factory default.

<b>Values</b>	Units <sup>1)</sup> : hours, days, years
	Range: <b>0.000</b> to <b>20.000</b> years
	Default: 10.000 years

<sup>1)</sup> Units are selectable only via SIMATIC PDM, PACTware FDT, and AMS.

### Time in Operation (3.3.3.2.)

Read only. The amount of time the device has been operating.

### Remaining Lifetime (3.3.3.3.)

Read only. Lifetime Expected (3.3.3.1.) (Page 252) less Time in Operation (3.3.3.2.) (Page 252).

### Reminder Activation (3.3.3.4.)

---

**Note**

To modify this parameter via SIMATIC PDM it must be accessed via the pull-down menu Device – Maintenance.

---

Allows you to enable a maintenance reminder.

<b>Options</b>		REMINDER 1 (MAINTENANCE REQUIRED)
		REMINDER 2 (MAINTENANCE DEMANDED)
		REMINDERS 1 AND 2
	*	OFF

1. First set the values in Reminder 1 before Lifetime (Required) (3.3.3.5.) (Page 253)/Reminder 2 before Lifetime (Demanded) (3.3.3.6.) (Page 253).
2. Select the desired Reminder Activation option.

**Reminder 1 before Lifetime (Required) (3.3.3.5.)**

If Remaining Lifetime (3.3.3.3.) (Page 252) is equal to or less than this value, the device generates a Maintenance Required reminder.

Values	Range: <b>0.000</b> to <b>20.000</b> years
	Default: <b>0.164</b> years (8 weeks)

1. Modify values as required.
2. Set Reminder Activation (3.3.3.4.) (Page 252) to the desired option.

**Reminder 2 before Lifetime (Demanded) (3.3.3.6.)**

If Remaining Lifetime (3.3.3.3.) (Page 252) is equal to or less than this value, the device generates a Maintenance Demanded reminder.

Values	Range: <b>0.000</b> to <b>20.000</b> years
	Default: <b>0.019</b> years (1 week)

1. Modify values as required.
2. Set Reminder Activation (3.3.3.4.) (Page 252) to the desired option.

**Maintenance Status (3.3.3.7.)**

Indicates which level of maintenance reminder is active.

In SIMATIC PDM, open the menu View – Device Status, click on the Maintenance tab, and check the Device Lifetime Status window.

**Acknowledged Status (3.3.3.8.)**

Indicates which level of maintenance reminder has been acknowledged.

In SIMATIC PDM, open the menu View – Device Status, click on the Maintenance tab, and check the Device Lifetime Status window.

**Acknowledged (3.3.3.9.)**

Acknowledges the current maintenance reminder.

**To acknowledge a reminder via SIMATIC PDM:**

1. Open the menu View – Device Status and click on the tab Maintenance.
2. In the Device Lifetime section, click on Acknowledge Warnings.

**To acknowledge a reminder via the local push buttons:**

1. Navigate to Maintenance and Diagnostics (3.) (Page 244) > Maintenance (3.3.) (Page 250) > Remaining Device Life (3.3.3.) (Page 251) > Acknowledged (3.3.3.9.), and RIGHT arrow  to acknowledge the reminder.

### 9.3.3.4 Remaining Sensor Life (3.3.4.)

---

**Note**

- Four sets of parameters allow you to monitor the Device/Sensor Lifetimes and set up Maintenance/Service schedules, based on operating hours instead of a calendar-based schedule. See also Remaining Device Life (3.3.3.) (Page 251), Service Schedule (3.3.5.) (Page 257), and Schedule (3.3.6.) (Page 260).
  - Performing a reset to Factory Defaults will reset all the Maintenance Schedule parameters to their factory defaults.
  - The device operates in years. To view Remaining Device Lifetime parameters in hours or days (only via SIMATIC PDM, PACTware FDT, and AMS) see Lifetime Expected (3.3.4.1.) (Page 254).
- 

The device monitors the predicted lifetime of the sensor (the components exposed to the vessel environment). You can modify the expected sensor lifetime, set up schedules for maintenance reminders, and acknowledge them.

**To access these parameters via SIMATIC PDM:**

- Open the menu Device – Maintenance and select the Remaining Sensor Lifetime tab. (For more details see Maintenance in LUT400Communications manual<sup>1</sup>.)

**Time Units**

Allows you to set the desired units.

Options <sup>2</sup>		HOURS
		DAYS
	*	YEARS

<sup>1</sup>) Communications for SITRANS LUT400 (HART) Manual (7ML19985NE01)

<sup>2</sup>) Units are selectable only via SIMATIC PDM, PACTware FDT, and AMS.

### Lifetime Expected (3.3.4.1.)

---

**Note**

The device always operates in years. Changing the Time Units affects only the parameter view of the Remaining Device Lifetime parameters in SIMATIC PDM, PACTware FDT, and AMS.

---

Allows you to override the factory default.

Values	Units <sup>1</sup> : hours, days, years
	Range: <b>0.000</b> to <b>20.000</b> years
	Default: 10.000 years

<sup>1</sup>) Units are selectable only via SIMATIC PDM, PACTware FDT, and AMS.

**Time in Operation (3.3.4.2.)**

The amount of time the sensor has been operating. Can be reset to zero after performing a service or replacing the sensor.

**To reset to zero:**

- In SIMATIC PDM, open the menu Device – Maintenance, click on the Remaining Sensor Lifetime tab, and click on Sensor Replaced to restart the timer and clear any fault messages.
- Via the local push buttons, navigate to Maintenance and Diagnostics (3.) (Page 244) > Maintenance (3.3.) (Page 250) > Remaining Sensor Life (3.3.4.) (Page 254) > Time in Operation (3.3.4.2.), and set to zero.

**Remaining Lifetime (3.3.4.3.)**

Read only. Lifetime Expected (3.3.4.1.) (Page 254) less Time in Operation (3.3.4.2.) (Page 255).

**Reminder Activation (3.3.4.4.)****Note**

To modify this parameter via SIMATIC PDM it must be accessed via the pull-down menu Device – Maintenance.

Allows you to enable a maintenance reminder.

<b>Options</b>		REMINDER 1 (MAINTENANCE REQUIRED)
		REMINDER 2 (MAINTENANCE DEMANDED)
		REMINDERS 1 AND 2
	*	OFF

1. First set the values in Reminder 1 before Lifetime (Required) (3.3.4.5.) (Page 255)/Reminder 2 before Lifetime (Demanded) (3.3.4.6.) (Page 256).
2. Select the desired Reminder Activation option.

**Reminder 1 before Lifetime (Required) (3.3.4.5.)**

If Remaining Lifetime (3.3.4.3.) (Page 255) is equal to or less than this value, the device generates a Maintenance Required reminder.

<b>Values</b>	Range: <b>0.000</b> to <b>20.000</b> years
	Default: <b>0.164</b> years (8 weeks)

1. Modify values as required.
2. Set Reminder Activation (3.3.4.4.) (Page 255) to the desired option.

**Reminder 2 before Lifetime (Demanded) (3.3.4.6.)**

If Remaining Lifetime (3.3.4.3.) (Page 255) is equal to or less than this value, the device generates a Maintenance Demanded reminder.

Values	Range: <b>0.000</b> to <b>20.000</b> years
	Default: <b>0.019</b> years (1 week)

1. Modify values as required.
2. Set Reminder Activation (3.3.4.4.) (Page 255) to the desired option.

**Maintenance Status (3.3.4.7.)**

Indicates which level of maintenance reminder is active.

In SIMATIC PDM, open the menu View – Device Status, click on the Maintenance tab, and check the Sensor Lifetime Status window.

**Acknowledged Status (3.3.4.8.)**

Indicates which level of maintenance reminder has been acknowledged.

In SIMATIC PDM, open the menu View – Device Status, click on the Maintenance tab, and check the Sensor Lifetime Status window.

**Acknowledged (3.3.4.9.)**

Acknowledges the current maintenance reminder.

**To acknowledge a reminder via SIMATIC PDM:**

1. Open the menu View – Device Status and click on the tab Maintenance.
2. In the Sensor Lifetime section, click on Acknowledge Warnings.

**To acknowledge a reminder via the local push buttons:**

1. Navigate to Maintenance and Diagnostics (3.) (Page 244) > Maintenance (3.3.) (Page 250) > Remaining Sensor Life (3.3.4.) (Page 254) > Acknowledged (3.3.4.9.), and RIGHT arrow ► to acknowledge the reminder.



### 9.3.3.5 Service Schedule (3.3.5.)

#### Note

- Four sets of parameters allow you to monitor the Device/Sensor Lifetimes and set up Maintenance/Service schedules, based on operating hours instead of a calendar-based schedule. See also Remaining Device Life (3.3.3.) (Page 251), Remaining Sensor Life (3.3.4.) (Page 254), and Schedule (3.3.6.) (Page 260).
- Performing a reset to Factory Defaults will reset all the Maintenance Schedule parameters to their factory defaults.
- The device operates in years. To view Remaining Device Lifetime parameters in hours or days (only via SIMATIC PDM, PACTware FDT, and AMS) see Service Interval (3.3.5.1.) (Page 257).

The device tracks service intervals based on operating hours and monitors the predicted lifetime to the next service. You can modify the Total Service Interval, set schedules for maintenance reminders, and acknowledge them.

The maintenance warnings and reminders are communicated to the end user through status information. This information can be integrated into any Asset Management system. For optimal use, we recommend that you use SIMATIC PCS7 Asset Management Software in conjunction with SIMATIC PDM.

#### To access these parameters via SIMATIC PDM:

- Open the menu Device – Maintenance and select the Service Schedule tab. (For more details see Maintenance in LUT400Communications manual<sup>1</sup>.)

#### Time Units

Allows you to set the desired units.

Options <sup>2</sup>		HOURS
		DAYS
	*	YEARS

<sup>1</sup>) Communications for SITRANS LUT400 (HART) Manual (7ML19985NE01)

<sup>2</sup>) Units are selectable only via SIMATIC PDM, PACTware FDT, and AMS.

### Service Interval (3.3.5.1.)

#### Note

The device always operates in years. Changing the Time Units affects only the parameter view of the Service Interval parameters in SIMATIC PDM, PACTware FDT, and AMS.

User-configurable recommended time between product inspections.

Values	Units <sup>1</sup> : hours, days, years
	Range: <b>0.000</b> to <b>20.000</b> years
	Default: <b>1.000</b> year

<sup>1</sup>) Units are selectable only via SIMATIC PDM, PACTware FDT, and AMS.

### Time Last Service (3.3.5.2.)

Time elapsed since last service. Can be reset to zero after performing a service.

**To reset to zero:**

- In SIMATIC PDM, open the menu Device – Maintenance, click on the Service Schedule tab, and click on Service Performed to restart the timer and clear any fault messages.
- Navigate to Maintenance and Diagnostics (3.) (Page 244) > Maintenance (3.3.) (Page 250) > Service Schedule (3.3.5.) (Page 257) > Time Last Service (3.3.5.2.), and set to zero.

### Time Next Service (3.3.5.3.)

Read only. Time Next Service (3.3.5.3.) less Time Last Service (3.3.5.2.) (Page 258).

### Reminder Activation (3.3.5.4.)

---

**Note**

To modify this parameter via SIMATIC PDM it must be accessed via the pull-down menu Device – Maintenance.

---

Allows you to enable a maintenance reminder.

<b>Values</b>	*	TIMER OFF
		ON NO LIMITS - no reminders checked
		ON REMINDER 1 (MAINTENANCE REQUIRED) checked
		ON REMINDER 1 AND 2 checked
		ON REMINDER 2 (MAINTENANCE DEMANDED) checked

1. First set the values in Reminder 1 before Service (Required) (3.3.5.5.) (Page 258)/Reminder 2 before Service (Demanded) (3.3.5.6.) (Page 259).
2. Select the desired Reminder Activation option.

### Reminder 1 before Service (Required) (3.3.5.5.)

If Time Next Service (3.3.5.3.) (Page 258) is equal to or less than this value, the device generates a Maintenance Required reminder.

<b>Values</b>	Range: <b>0.000</b> to <b>20.000</b> years
	Default: <b>0.164</b> years (8 weeks)

1. Modify values as required.
2. Set Reminder Activation (3.3.5.4.) (Page 258) to the desired option.

**Reminder 2 before Service (Demanded) (3.3.5.6.)**

If Time Next Service (3.3.5.3.) (Page 258) is equal to or less than this value, the device generates a Maintenance Demanded reminder.

Values	Range: <b>0.000</b> to <b>20.000</b> years
	Default: <b>0.019</b> years (1 week)

1. Modify values as required.
2. Set Reminder Activation (3.3.5.4.) (Page 258) to the desired option.

**Maintenance Status (3.3.5.7.)**

Indicates which level of maintenance reminder is active.

In PDM, open the menu View – Device Status, click on the Maintenance tab and check the Service Schedule Status window.

**Acknowledged Status (3.3.5.8.)**

Indicates which level of maintenance reminder has been acknowledged.

In PDM, open the menu View – Device Status, click on the Maintenance tab and check the Service Schedule Status window.

**Acknowledged (3.3.5.9.)**

Acknowledges the current maintenance reminder.

**To acknowledge a reminder via SIMATIC PDM:**

1. Open the menu View – Device Status and click on the tab Maintenance.
2. In the Service Schedule Status section, click on Acknowledge Warnings.

**To acknowledge a reminder via the local push buttons:**

1. Navigate to Maintenance and Diagnostics (3.) (Page 244) > Maintenance (3.3.) (Page 250) > Service Schedule (3.3.5.) (Page 257) > Acknowledged (3.3.5.9.), and RIGHT arrow ► to acknowledge the reminder.

### 9.3.3.6 Schedule (3.3.6.)

---

**Note**

- Four sets of parameters allow you to monitor the Device/Sensor Lifetimes and set up Maintenance/Service schedules, based on operating hours instead of a calendar-based schedule. See also Remaining Device Life (3.3.3.) (Page 251), Remaining Sensor Life (3.3.4.) (Page 254), and Service Schedule (3.3.5.) (Page 257).
  - Performing a reset to Factory Defaults will reset all the Maintenance Schedule parameters to their factory defaults.
  - The device operates in years. To view Calibration Interval parameters in hours or days (only via SIMATIC PDM, PACTware FDT, and AMS) see Calibration Interval (3.3.6.1.) (Page 260).
- 

The device tracks calibration intervals based on operating hours and monitors the predicted lifetime to the next calibration. You can modify the Total Calibration Interval, set schedules for maintenance reminders, and acknowledge them.

**To access these parameters via SIMATIC PDM:**

- Open the menu Device – Maintenance and select the Calibration Schedule tab. (For more details see Maintenance in LUT400Communications manual<sup>1</sup>.)

**Time Units**

Allows you to set the desired units.

<b>Options<sup>2</sup></b>		HOURS
		DAYS
	*	YEARS

<sup>1</sup>) Communications for SITRANS LUT400 (HART) Manual (7ML19985NE01)

<sup>2</sup>) Units are selectable only via SIMATIC PDM, PACTware FDT, and AMS.

### Calibration Interval (3.3.6.1.)

---

**Note**

The device always operates in years. Changing the units affects only the parameter view of the Calibration Interval parameters in SIMATIC PDM, PACTware FDT, and AMS.

---

User-configurable recommended time between product calibrations.

<b>Values</b>	Units <sup>1</sup> : hours, days, years
	Range: <b>0.000</b> to <b>20.000</b> years
	Default: <b>1.000</b> year

<sup>1</sup>) Units are selectable only via SIMATIC PDM, PACTware FDT, and AMS.

**Time Last Calibration (3.3.6.2.)**

Time elapsed since last calibration. Can be reset to zero after performing a calibration.

**To reset to zero:**

- In SIMATIC PDM, open the menu Device – Maintenance, click on the Calibration Schedule tab, and click on Calibration Performed to restart the timer and clear any fault messages.
- Via the local push buttons, navigate to Maintenance and Diagnostics (3.) (Page 244) > Maintenance (3.3.) (Page 250) > Schedule (3.3.6.) (Page 260) > Time Last Calibration (3.3.6.2.), and set to zero.

**Time Next Calibration (3.3.6.3.)**

Read only. Calibration Interval (3.3.6.1.) (Page 260) less Time Last Calibration (3.3.6.2.) (Page 261).

**Reminder Activation (3.3.6.4.)****Note**

To modify this parameter via SIMATIC PDM it must be accessed via the pull-down menu Device – Maintenance.

Allows you to enable a maintenance reminder.

Values	*	
		TIMER OFF
		ON NO LIMITS - no reminders checked
		ON REMINDER 1 (MAINTENANCE REQUIRED) checked
		ON REMINDER 1 AND 2 checked
		ON REMINDER 2 (MAINTENANCE DEMANDED) checked

1. First set the values in Reminder 1 before Calibration (Required) (3.3.6.5.) (Page 261)/Reminder 2 before Calibration (Demanded) (3.3.6.6.) (Page 262).
2. Select the desired Reminder Activation option.

**Reminder 1 before Calibration (Required) (3.3.6.5.)**

If Time Next Calibration (3.3.6.3.) (Page 261) is equal to or less than this value, the device generates a Maintenance Required reminder.

Values	
	Range: <b>0.000</b> to <b>20.000</b> years
	Default: <b>0.164</b> years (8 weeks)

1. Modify values as required.
2. Set Reminder Activation (3.3.6.4.) (Page 261) to the desired option.

**Reminder 2 before Calibration (Demanded) (3.3.6.6.)**

If Time Next Calibration (3.3.6.3.) (Page 261) is equal to or less than this value, the device generates a Maintenance Demanded reminder.

Values	Range: <b>0.000</b> to <b>20.000</b> years
	Default: <b>0.019</b> years (1 week)

1. Modify values as required.
2. Set Reminder Activation (3.3.6.4.) (Page 261) to the desired option.

**Maintenance Status (3.3.6.7.)**

Indicates which level of maintenance reminder is active.

In SIMATIC PDM, open the menu View – Device Status, click on the Maintenance tab and check the Calibration Schedule Status window.

**Acknowledged Status (3.3.6.8.)**

Indicates which level of maintenance reminder has been acknowledged.

In SIMATIC PDM, open the menu View – Device Status, click on the Maintenance tab and check the Calibration Schedule Status window.

**Acknowledged (3.3.6.9.)**

Acknowledges the current maintenance reminder.

**To acknowledge a reminder via SIMATIC PDM:**

1. Open the menu View – Device Status and click on the tab Maintenance.
2. In the Calibration Schedule Status section, click on Acknowledge Warnings.

**To acknowledge a reminder via the local push buttons:**

1. Navigate to Maintenance and Diagnostics (3.) (Page 244) > Maintenance (3.3.) (Page 250) > Schedule (3.3.6.) (Page 260) > Acknowledged (3.3.6.9.), and RIGHT arrow ► to acknowledge the reminder.

**9.3.4 Simulation (3.4.)**

Use simulation to test your application. For further details, see Application examples (Page 79).

**9.3.4.1 Level (3.4.1.)**

Simulates level changes, and activates relays based on the setpoints programmed.

**Level Simulation Enable (3.4.1.1.)**

Enables/disables level simulation.

Options	*	DISABLED
		ENABLED

**Level Value (3.4.1.2.)**

Enables/disables level simulation.

Values	Range: <b>Low Calibration Point to High Calibration Point</b>
	Default: 0.000

**Ramp (3.4.1.3.)**

Enables/disables ramped simulation.

Options	*	DISABLED
		ENABLED

**Ramp Rate (3.4.1.4.)**

Sets the rate at which the simulated level will change in a ramp simulation.

Options		SLOW	1% of span <sup>1</sup> per second
	*	MEDIUM	2% of span <sup>1</sup> per second
		FAST	4% of span <sup>1</sup> per second

<sup>1)</sup> Low Calibration Point to High Calibration Point

**9.3.4.2 Discrete Inputs (3.4.2.)**

Simulates behavior of external contacts connected to a discrete input.

**Discrete Input 1 (3.4.2.1.)**

Disables simulation of Discrete Input 1, or sets behavior of DI during simulation.

Options	*	DISABLED	DI is not simulated
		ON	DI is simulated to be ON
		OFF	DI is simulated to be OFF

**Discrete Input 2 (3.4.2.2.)**

Disables simulation of Discrete Input 2, or sets behavior of DI during simulation.

Options	*	DISABLED	DI is not simulated
		ON	DI is simulated to be ON
		OFF	DI is simulated to be OFF

**9.3.4.3 Pump Activations (3.4.3.)**

Sets how physical relays (that are assigned to pumps) will behave in simulation mode.

Options	*	DISABLED	Pump relays are not activated in simulation
		ENABLED	Pump relays are activated in simulation

**9.4 Communication (4.)****9.4.1 Device Address (4.1.)**

Sets the device address or poll ID on a HART network.

Values	Range: <b>0 to 63</b> (Set within range of 0 to 15 if HART 5 master used.)
	Default: <b>0</b>

**To reset Device Address via SIMATIC PDM:**

- Open the project in Process Device Network View then right-click on the device.
- Go to Object Properties and open the Connection tab to access the field Short Address.

**Note**

The following list of parameters are available in PDM. Unless otherwise stated, the options are displayed in integer format (as required by HART communications).

**Manufacturer's ID**

Read only. Numerical code that refers to the manufacturer of the device (e.g. 42, which refers to Siemens).

**Device Id**

Read only. Unique identification of the device by manufacturer and device type.

**Product Id**

Read only. Unique identification of the product by model number.



**Device Revision**

Read only. Device revision associated with a specific EDD.

**EDD Revision**

Read only. Revision of a specific EDD associated with the device.

**Universal Command Revision**

Read only. Revision of the Universal Device Description associated with the device.

**Protocol**

Read only. The communication protocol supported by the device.

**Common Practice Command Revision**

Read only. Revision of the set of HART common practice commands supported by the device.

**Configuration Change Counter**

Read only. Indicates the number of times the device's configuration or calibration has been changed by a host application or from a local operator interface.

## 9.5 Security (5.)

**Note**

Default settings in the parameter tables are indicated with an asterisk (\*) unless explicitly stated.

### 9.5.1 Write Protection (5.1.)

A password to prevent any changes to parameters via local push buttons, remote communication, or Windows-based web browser. Write Protection must match User PIN (5.2.) (Page 266) for the device to be unlocked.

Values		Range: 0 to 65535	
	*	Unlock value (2457)	Lock Off
		Any other value	Lock On

- To turn Lock On, key in any value other than the Unlock Value.
- To turn Lock Off, key in the Unlock Value (2457).

### 9.5.2 User PIN (5.2.)

This is a private password to prevent any changes to the parameters via local push buttons, remote communications, or Windows-based web browser.

Values		Range	0 to 65535
	*	Default value	2457

- To view or change the User PIN, 5.1. Write Protection must match the current User PIN value. If the PIN does not match 5.1. Write Protection '\*\*\*\*\*' will be displayed.
- If '\*\*\*\*\*' is displayed, the LUT400 parameters cannot be changed and will display the lock icon, except for 5.1 Write Protection.
- User PIN cannot be changed via communications.

#### Note

The User PIN value cannot be recovered in the field. Record a new user PIN in a secure manner.

## 9.6 Language (6.)

#### Note

Default settings in the parameter tables are indicated with an asterisk (\*) unless explicitly stated.

Selects the language to be used on the LCD.

Options	*	ENGLISH
		DEUTSCH
		FRANCAIS
		ESPANOL
		简体中文
		ITALIANO
		PORTUGUÊS
		русский

#### Characteristics

#### Certificates & Approvals

Device Certification

The approvals certificates applicable to the device.

SITRANS LUT400 requires no maintenance or cleaning under normal operating conditions.

## 10.1 Firmware updates

To update the LUT400 firmware, please contact your Siemens representative to obtain the installer (self-executable .exe file). For a complete list of representatives, go to <http://www.siemens.com/processautomation> (<http://www.siemens.com/processautomation>).

Two installers are available: one to update the firmware in the Local User Interface (LUI) node, and one for the sensor node. One or both may be required, depending on the reason for the update.

To complete an update, follow steps in the installer:

1. Connect your computer to the SITRANS LUT400 USB port.
2. Before running the .exe installer received from your Siemens representative, note the computer COM port to which the LUT400 is connected.
3. From your computer, double-click the .exe, and follow the installer steps. The first step will prompt for Communication Options. These options are set to factory defaults. Ensure the COM Port is set to that noted in step 2 above. No other changes are required.
4. Follow remaining installer steps.
5. Once complete, verify the update was successful by checking the current firmware revision:
  - If updating the LUI node, recycle the power on the LUT400. On power-up, you will see the current LUI firmware revision on the LUT400 display.
  - If updating the sensor node, view parameter Firmware Revision (3.1.11.) (Page 245) to see the current sensor node firmware revision.

Complete a Master Reset (3.2.3.) (Page 247) to factory defaults after a successful upgrade of the sensor node, before re-entering parameters.

## 10.2 Transferring parameters using LUT400 display lid

If necessary to transfer parameters from one LUT400 to another, the LUI display maintains a backup file of the parameters on the device. With this backup file, it is possible to connect the remote lid to a second LUT400 to transfer parameters.

When the remote lid is connected to a second device, a fault code is displayed to note that the LUI backup file does not match the configuration file in the sensor. You can then use the Backup Control parameter to specify that sensor parameters be copied from the LUI backup to the device [see Backup Control (3.3.2.) (Page 251)].

## 10.3 Replacing the Battery

The battery (BR2032) has a life expectancy of ten years, and is affected by ambient temperature. If the device loses external power the battery will maintain the SITRANS LUT400's Real Time Clock (date and time) until power is restored.

The flash memory is updated constantly. Therefore, data logs are unaffected by the loss of power.

<p><b>! WARNING</b></p> <p><b>Disconnect power before replacing the battery.</b></p> <ul style="list-style-type: none"><li>• To replace, remove the existing battery from the holder as shown below, and reinstall replacement battery (BR2032).</li><li>• Battery Type: Lithium metal coin cell Battery Chemistry: solid-cathode Carbon Monofluoride</li></ul>
---

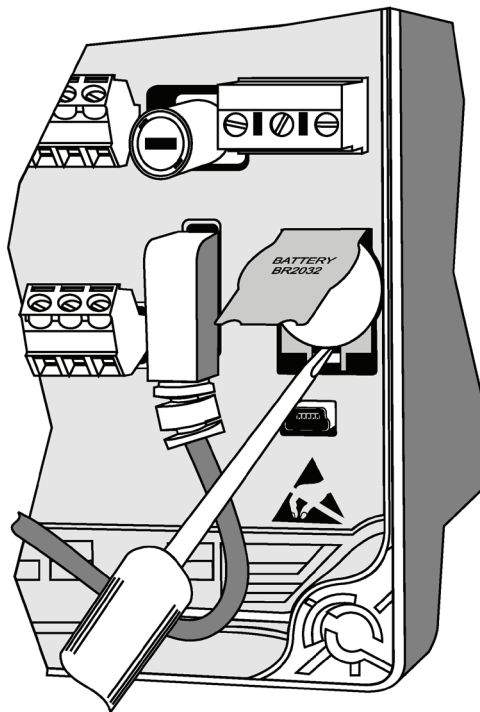

1. Open the enclosure lid.
2. Slide the end of a screwdriver under the lip of the plastic battery cover, and lift cover with fingers. (Do not press back on fold.)
3. While holding cover in raised position, place end of screwdriver at an angle into slot below battery, and pry upward.
4. Lift out battery.
5. Insert new battery and press down on face of battery to secure in holder.

6. Press down on plastic battery cover to secure in place.
7. Close enclosure lid and tighten screws.
8. Reset the Real Time Clock (See Date and Time (2.14.) (Page 232))

## 10.4 Disposal



Devices described in this manual should be recycled. They may not be disposed of in the municipal waste disposal services according to the Directive 2012/19/EC on waste electronic and electrical equipment (WEEE).

Devices can be returned to the supplier within the EC, or to a locally approved disposal service for eco-friendly recycling. Observe the specific regulations valid in your country.

Further information about devices containing batteries can be found at: Information about battery/product return (WEEE) (<https://support.industry.siemens.com/cs/document/109479891/>)

## 10.5 Return of products with lithium batteries

---

### Note

#### Return of products with lithium batteries

Lithium batteries are dangerous goods according to the Regulation of Dangerous Goods, UN 3090 and UN 3091.

- Remove lithium batteries prior to shipment.
  - If the battery cannot be removed, return the product according to the Regulation of Dangerous Goods with special transport documentation.
- 

## 10.6 Return procedure

Enclose the bill of lading, return document and decontamination certificate in a clear plastic pouch and attach it firmly to the outside of the packaging.

### Required forms

- Delivery note
- Return goods delivery note (<http://www.siemens.com/processinstrumentation/returngoodsnote>)  
with the following information:
  - Product (item description)
  - Number of returned devices/replacement parts
  - Reason for returning the item(s)
- Decontamination declaration (<http://www.siemens.com/sc/declarationofdecontamination>)

With this declaration you warrant "that the device/replacement part has been carefully cleaned and is free of residues. The device/replacement part does not pose a hazard for humans and the environment."

If the returned device/replacement part has come into contact with poisonous, corrosive, flammable or water-contaminating substances, you must thoroughly clean and decontaminate the device/replacement part before returning it in order to ensure that all hollow areas are free from hazardous substances. Check the item after it has been cleaned.

Any devices/replacement parts returned without a decontamination declaration will be cleaned at your expense before further processing.

---

**Note**

- Many of the parameters referenced and techniques described here require a good understanding of ultrasonic technologies and Siemens echo processing software. Use this information with caution.
  - If the setup becomes too confusing do a Master Reset (3.2.3.) (Page 247) and start again.
  - As a further resource, Understanding Ultrasonic Level Measurement is available on our website. Go to [www.siemens.com/level](http://www.siemens.com/level) ([www.siemens.com/level](http://www.siemens.com/level)).
- 

## 11.1 Communication Troubleshooting

### 11.1.1 Generally





























1. Check the following:
  - There is power at the device
  - The optional LCD is showing the relevant data
  - The device can be programmed using the local push buttons.
  - If any fault codes are being displayed, see General Fault Codes (Page 273) for a detailed list.
2. Verify that the wiring connections are correct.

### 11.1.2 Specifically





1. The SITRANS LUT400 is set to communicate via a HART modem but no communication is returning to the master.
  - Check that the device address is set correctly for the HART network.
2. A SITRANS LUT400 parameter is set via remote communications, but the parameter remains unchanged.
  - Try setting the parameter from the local push buttons. If it can not be set using the buttons, ensure Write Protection (5.1.) (Page 265) is set to the unlock value.

If you continue to experience problems, go to our website at: [www.siemens.com/sitransLUT400](http://www.siemens.com/sitransLUT400) ([www.siemens.com/sitransLUT400](http://www.siemens.com/sitransLUT400)), and check the FAQs for SITRANS LUT400, or contact your Siemens representative.

## 11.2 Device Status Icons

LUI Icon	PDM Icon	Priority Level <sup>1</sup>	Meaning
		1	<ul style="list-style-type: none"> <li>Maintenance alarm</li> <li>Measurement values are not valid</li> </ul>
		2	<ul style="list-style-type: none"> <li>Maintenance warning: maintenance demanded immediately</li> <li>Measured signal still valid</li> </ul>
		3	<ul style="list-style-type: none"> <li>Maintenance required</li> <li>Measured signal still valid</li> </ul>
		1	<ul style="list-style-type: none"> <li>Process value has reached an alarm limit</li> </ul>
		2	<ul style="list-style-type: none"> <li>Process value has reached a warning limit</li> </ul>
		3	<ul style="list-style-type: none"> <li>Process value has reached a tolerance limit</li> </ul>
		1	<ul style="list-style-type: none"> <li>Configuration error</li> <li>Device will not work because one or more parameters/components is incorrectly configured</li> </ul>
		2	<ul style="list-style-type: none"> <li>Configuration warning</li> <li>Device can work but one or more parameters/components is incorrectly configured</li> </ul>
		3	<ul style="list-style-type: none"> <li>Configuration changed</li> <li>Device parameterization not consistent with parameterization in project. Look for info text.</li> </ul>
		1	<ul style="list-style-type: none"> <li>Manual operation (local override)</li> <li>Communication is good; device is in manual mode.</li> </ul>
		2	<ul style="list-style-type: none"> <li>Simulation or substitute value</li> <li>Communication is good; device is in simulation mode or works with substitute values.</li> </ul>
		3	<ul style="list-style-type: none"> <li>Out of operation</li> <li>Communication is good; device is out of action.</li> </ul>
			<ul style="list-style-type: none"> <li>Data exchanged</li> </ul>
			<ul style="list-style-type: none"> <li>No data exchange</li> </ul>











LUI Icon	PDM Icon	Priority Level <sup>1</sup>	Meaning
			<ul style="list-style-type: none"> <li>Write access enabled</li> </ul>
			<ul style="list-style-type: none"> <li>Write access disabled</li> </ul>















<sup>1)</sup> Lowest priority number equals highest fault severity.























## 11.3 General Fault Codes

### Note















- If two faults are present at the same time, the device status indicator and text for the highest priority fault will display.
- Certain faults exist, such as with a loss of echo (LOE) or a broken cable, that when triggered cause the mA output to go to a fail-safe reading (see Fail-Safe (2.4.) (Page 179)) and LUI to display dashes (-----) until fault is cleared. These faults are indicated with an asterisk (\*) in the table below.

General Fault Codes				
Code / LUI Icon	Code / PDM Icon		Meaning	Corrective Action
0 	0 	*	Loss of echo (LOE). The device was unable to get a measurement within the Fail-safe LOE Timer period. Possible causes: faulty installation, foaming/other adverse process conditions, invalid calibration range.	<ul style="list-style-type: none"> <li>Ensure installation details are correct.</li> <li>Adjust process conditions to minimize adverse conditions.</li> <li>Correct range calibration.</li> <li>If fault persists, contact your local Siemens representative.</li> </ul>
1 	1 	*	Cable fault. Broken cable.	Inspect attached cabling and any termination points to ensure no disconnection or damage; repair/replace if necessary. If no issue with cabling, contact your local Siemens representative.
3 	3 		Device is nearing its lifetime limit according to the value set in Maintenance Required Limit.	Replacement is recommended.
4 	4 		Device is nearing its lifetime limit according to the value set in Maintenance Demanded Limit.	Replacement is recommended.

General Fault Codes				
Code / LUI Icon	Code / PDM Icon		Meaning	Corrective Action
5 			Saving Parameters. (LUI fault only.) Saving is in progress. Do not turn off the device.	Wait for completion.
6 	6 		Sensor is nearing its lifetime limit according to the value set in Maintenance Required Limit.	Replacement is recommended.
7 	7 		Sensor is nearing its lifetime limit according to the value set in Maintenance Demanded Limit.	Replacement is recommended.
8 	8 		Service interval as defined in Maintenance Required Limit has expired.	Perform service.
9 	9 		Service interval as defined in Maintenance Demanded Limit has expired.	Perform service.
10 	10 		Configuration parameters are incorrect. The following conditions will cause this fault: <ul style="list-style-type: none"> <li>• Far Range &lt; Low Cal. Pt.</li> <li>• Near Range &gt; Far Range</li> <li>• Low Cal. Pt - High Cal. Pt. &lt; 10 cm</li> <li>• Far Range - Near Range &lt; 10 cm</li> <li>• Max. mA Limit ≤ Min. mA Limit</li> <li>• Current Output Function set to Volume, but Vessel Shape set to None</li> <li>• Current Output Function set to Volume, but Max. Volume has not been set.</li> </ul>	Check device configuration.
17 	17 		Calibration interval as defined in Maintenance Required Limit has expired.	Perform calibration.
18 	18 		Calibration interval as defined in Maintenance Demanded Limit has expired.	Perform calibration.

General Fault Codes				
Code / LUI Icon	Code / PDM Icon		Meaning	Corrective Action
25 	25 		Internal device error.	Reset power. If fault persists, contact your local Siemens representative.
26 	26 	*	Submergence detected. The transducer appears submerged.	Correct the installation.
27 	27 		Incorrect product model. Basic model does not support flow and advanced pump control features	Only configure the supported features.
39 	39 	*	Transducer temperature sensor has failed.	Inspect attached cabling and any termination points to ensure no disconnection or damage; repair/replace if necessary. If no issue with cabling, contact your local Siemens representative.
46 	46 	*	The TS-3 temperature sensor failed.	Inspect attached cabling and any termination points to ensure no disconnection or damage; repair/replace if necessary. If no issue with cabling, contact your local Siemens representative.
47 	47 		Poor signal from the application. Poor installation or high noise level.	Verify installation.
121 	121 		Flow calculations are not configured properly. Incorrect parameter settings.	Reconfigure the unit. Check the configuration. If fault persists, do a master reset.
122 	122 		Flow calculations encountered an error.	Reconfigure the unit. Check the breakpoints. If fault persists, do a master reset.
123 	123 		Flow log could not restore the settings.	Reconfigure the unit. Check the flow log settings. If fault persists, do a master reset.
124 	124 		Flow log is not configured properly.	Reconfigure the unit. Check the flow log settings. If fault persists, do a master reset.
125 	125 		Flow log error. Log failed.	Verify that the drive where the log file resides is not full. Copy the log file to a computer and delete it from the device.

11.4 Common Problems Chart

General Fault Codes				
Code / LUI Icon	Code / PDM Icon		Meaning	Corrective Action
126 	126 		Failed to open log file.	Verify that the drive where the log file resides is not full. Copy the log file to a computer and delete it from the device.
127 	127 		Failed to close log file.	Verify that the drive where the log file resides is not full. Copy the log file to a computer and delete it from the device.
128 	128 		Log file read error. Error reading file. Unexpected error.	Verify that the drive where the log file resides is not full. Copy the log file to a computer and delete it from the device.
130 	130 		Configuration error. One or more settings invalid.	Adjust/correct relay assignments or setpoints.
131 	131 		Parameter backup did not succeed. Communication or file system problems.	Repair required. Contact your local Siemens representative.
132 	132 		User input required. Serial numbers mismatch.	Manually force recovery. (Set parameter Backup Control (3.3.2.) (Page 251).)
133 	133 		Simulation Enabled.	Simulation is active. Enable or disable simulation via LUI (Level Simulation Enable (3.4.1.1.) (Page 263), Discrete Input 1 (3.4.2.1.) (Page 263), Discrete Input 2 (3.4.2.2.) (Page 264)).

## 11.4 Common Problems Chart

Symptom	Possible Cause	Action
Display blank, transducer not pulsing	No power, incorrect power	Check mains voltage at terminals; Check fuse; Check wiring connections; Check wiring.
Display blank, transducer is pulsing	Loose or disconnected display cable	Reconnect display cable.

Symptom	Possible Cause	Action
Display active, transducer not pulsing	Incorrect transducer connections or wiring; Incorrect transducer selection (or set to NO Transducer); Transducer has been disabled through the software	Verify terminal connections; Check transducer field wiring; Check any junction box connections; Check that transducer is enabled (see Transducer Enable (3.3.1.) (Page 250))
Reading fluctuates while material level is still	Material level is changing	Visually verify, if possible.
	Strong false echoes	Determine source of false echoes; Relocate transducer to avoid source.
	Incorrect damping	Adjust damping. See Damping Filter (2.3.3.) (Page 178).
	Improper echo Algorithm selection	Set algorithm to default. If no improvement, try a different algorithm. See Algorithm (2.12.2.1.) (Page 224).
	High noise levels	Verify source and minimize. See Noise Problems (Page 280).
	Weak echo	Determine cause; Check noise, confidence, FOM, and echo strength. See Echo Quality (3.2.9.) (Page 249).
	Foam on surface of material	Eliminate source of foaming; Use stilling well.
	Rapid temperature changes	Use an external temperature sensor. See Temperature Source (2.12.1.3.) (Page 222).
	Faulty temperature sensor	Verify operation; Replace if required, or use fixed temperature. See Temperature Source (2.12.1.3.) (Page 222).
	Vapors	If fluctuation is unacceptable, consider an alternative technology. Contact your Siemens representative.
Reading is fixed, but material level changes or reading does not follow material level	Incorrect speed of response	Verify response speed setting is adequate for process. See Quick Start (Page 59) (set in the Quick Start Wizard).
	Loss of Echo condition (LOE)	Check Noise, Echo Strength, Confidence. See Echo Quality (3.2.9.) (Page 249). Check LOE Timer is not set too short. See LOE Timer (2.4.2.) (Page 179).
	Agitator blade stopped in front of transducer (false echo)	Ensure agitator is running.
	Foam on surface of material	Eliminate source of foaming. Use stilling well
	Incorrect Algorithm used	Set algorithm to default. If no improvement, try a different algorithm. See Algorithm (2.12.2.1.) (Page 224).

11.4 Common Problems Chart

Symptom	Possible Cause	Action
	Transducer mounting: wrong location or incorrectly mounted	Ensure beam has a clear path to material surface; Verify transducer is not too tight; Use an isolation coupling.
	Incorrect transducer used for the application	Use correct transducer. Contact your Siemens representative.
	Unavoidable false echoes from obstructions	Relocate transducer to ensure beam has a clear path to material surface; Use manual TVT shaping or Auto False Echo Suppression. See TVT Shaper (2.12.4.) (Page 229) or Auto False Echo Suppression (2.12.3.1.) (Page 227).
Accuracy Varies	Faulty temperature sensor	Verify operation; Replace if required, or use fixed temperature. See Temperature Source (2.12.1.3.) (Page 222).
	Vapors present in varying concentrations	Eliminate vapors or consider a different technology. Contact your Siemens representative.
	Thermal gradients	Insulate vessel; Consider external temperature sensor.
	Calibration required	If accuracy is better when level is close to transducer, and worse when level is far from transducer, perform calibration [see Auto Sound Velocity (2.12.1.6.) (Page 223).] If accuracy is consistently incorrect, use Sensor Offset (2.2.3.) (Page 176) or perform calibration [see Auto Sensor Offset (2.2.6.) (Page 177)].
Reading erratic	Transducer mounting: wrong location or incorrectly mounted	Ensure beam has a clear path to material surface; Verify transducer is not too tight; Use an isolation coupling.
	Unavoidable false echoes from obstructions	Use Auto False Echo Suppression. See Auto False Echo Suppression (2.12.3.1.) (Page 227).
	Confidence too low	Check Noise, Echo Strength, Confidence. See Echo Quality (3.2.9.) (Page 249). Check LOE Timer is not set too short. See LOE Timer (2.4.2.) (Page 179).
	Multiple echoes	Check mounting location; Verify material is not entering Near Range zone. See Near Range (2.2.4.) (Page 176).

Symptom	Possible Cause	Action
	Noise in the application	Verify source and minimize. See Noise Problems (Page 280).
Incorrect reading (mA output and/or displayed value)	mA function not assigned to correct measurement	Check mA assignment. See Current Output Function (2.5.1.) (Page 180).
	When device configured for flow: exponent or breakpoint not correctly selected	Check configuration: if Sensor Mode (2.1.2.) (Page 173) set to FLOW, verify correct exponent [Flow Exponent (2.15.3.2.) (Page 236)] and breakpoints [Universal Head versus Flow (2.15.5.) (Page 241)].
	Incorrect vessel or PMD dimensions	For volume application: Verify vessel dimensions. See Vessel Shape (2.6.1.) (Page 184). For flow application: Verify PMD dimensions. See PMD Dimensions (2.15.4.) (Page 239).
Relay not activating	Relay not programmed	Program relay.
	Relay incorrectly assigned	Verify with simulation. See Simulation (3.4.) (Page 262).
	Incorrect relay function selected	Verify with simulation. See Simulation (3.4.) (Page 262).
	Incorrect relay setpoints	Verify setpoints.
Relay not activating correctly	Relay incorrectly assigned	Verify with simulation. See Simulation (3.4.) (Page 262).
	Incorrect relay function selected	Verify with simulation. See Simulation (3.4.) (Page 262).
	Incorrect relay setpoints	Verify setpoints.
No response when echo profile requested via LUI (Echo Profile (3.2.1.) (Page 246))	Transducer is disabled.	Set Transducer Enable (3.3.1.) (Page 250) to ENABLED, then request an echo profile.
Configuration error 130 displayed	Relay/pump configuration errors - possible causes include: <ul style="list-style-type: none"> <li>A relay is assigned to more than one function (e.g. relay 2 is assigned to both an external totalizer and a pump).</li> <li>Pump setpoints are out of order.</li> <li>Wall Cling adjustment range is too large.</li> </ul>	<ul style="list-style-type: none"> <li>Verify that each relay is assigned to one function only. Review relay assignments under Pumps (2.7.) (Page 189) and Other Control (2.11.) (Page 216).</li> <li>Verify that all 'ON' setpoints are greater than their respective 'OFF' setpoints for pump down applications (or vice versa for pump up applications).</li> <li>Ensure range set in Level Setpoint Variation (2.7.2.1.2) (Page 192) has not caused 'ON' or 'OFF' setpoints to overlap.</li> </ul>

Symptom	Possible Cause	Action
Echo profile request results in an error icon that displays for 5 seconds before returning to the echo profile request menu.	Another external communication is trying to access an echo profile at the same time.	Wait for several seconds and then retry the echo profile request, or disconnect / disable any external communications that may be requesting an echo profile.
Data log files are empty or logging has stopped.	<ul style="list-style-type: none"> <li>Data Logging is not enabled.</li> <li>USB extension cable has been used (although may not currently be connected).</li> </ul>	<ul style="list-style-type: none"> <li>Verify that Data Logging is enabled. See Data Logging (2.10.) (Page 214).</li> <li>If a USB extension cable has been used (remove if currently connected), a power reset of the device is required to restart Data Logging.</li> </ul>

## 11.5 Noise Problems

Incorrect readings can be the result of noise problems, either acoustic or electrical, in the application.

The noise present at the input to the ultrasonic receiver can be determined by viewing the echo profile locally via the LUI, or alternatively, using remote software such as SIMATIC PDM, AMS Device Manager, FC375/475, or DTM. View also parameters Noise Average (3.2.9.4.) (Page 250) and Noise Peak (3.2.9.5.) (Page 250). In general, the most useful value is the average noise.

With no transducer attached the noise is under 5 dB. This is often called the noise floor. If the value with a transducer attached is greater than 5 dB, signal processing problems can occur. High noise decreases the maximum distance that can be measured. The exact relationship between noise and maximum distance is dependent on the transducer type and the material being measured. An average noise level greater than 30 dB may be cause for concern if the installed transducers maximum operation range matches the range of the application (e.g. 8 m application using an 8 m XRS-5). Using a larger transducer with greater transmitted energy should help to improve performance in a noise condition.

### 11.5.1 Determine the Noise Source

Disconnect the transducer from the SITRANS LUT400. If the measured noise is below 5 dB, then continue here. If the measured noise is above 5 dB go to Non-Transducer Noise Sources below.

1. Connect only the shield wire of the transducer to the SITRANS LUT400. If the measured noise is below 5 dB, continue with the next step. If the noise is above 5 dB, go to Common Wiring Problems below.
2. Connect the white and black transducer wires to the SITRANS LUT400. Record the average noise.



3. Remove the positive wire of the transducer. Record the average noise.
4. Re-connect the positive wire and remove the negative wire. Record the average noise.

Using the table below, determine the appropriate next step. The terms higher, lower and unchanged refer to the noise recorded in the previous steps.

These are guidelines only. If the suggested solution does not solve the problem, try the other options also.

	-removed	+removed	Go to:
<b>noise</b>	higher	higher	Reducing Electrical Noise (Page 282)
		unchanged	Common Wiring Problems (Page 282)
		lower	Reducing Acoustical Noise (Page 282)
	unchanged	higher	Reducing Electrical Noise (Page 282)
		unchanged	Contact Siemens representative.
		lower	Reducing Acoustical Noise (Page 282)
	lower	higher	Common Wiring Problems (Page 282)
		unchanged	Common Wiring Problems (Page 282)
		lower	Reducing Acoustical Noise (Page 282)

### 11.5.1.1 Acoustical Noise

To confirm that the problem is acoustical, place several layers of cardboard over the face of the transducer. If the noise is reduced, the noise is definitely acoustical.

### 11.5.2 Non-Transducer Noise Sources

Remove all input and output cables from the SITRANS LUT400 individually while monitoring the noise. If removing a cable reduces the noise, that cable may be picking up noise from adjacent electrical equipment. Check that low voltage cables are not being run adjacent to high voltage cables or near to electrical noise generators such as variable speed drives.

Filtering cables is an option but is not recommended unless all other options have been exhausted.

The SITRANS LUT400 is designed to work near heavy industrial equipment such as variable speed drives. Even so, it should not be located near high voltage wires or switch gear.

Try moving the electronics to a different location. Often moving the electronics a few meters farther from the source of noise will fix the problem. Shielding the electronics is also an option, but it should be a last resort. Proper shielding is expensive and is difficult to install properly—the shielding box must enclose the SITRANS LUT400 electronics completely, and all wires must be brought to the box through grounded metal conduit.

### 11.5.3 Common Wiring Problems

- Make sure that the transducer shield wire is connected at the electronics end only. Do not ground it at any other location.
- Do not connect the transducer shield wire to the white wire.
- The exposed transducer shield wire must be as short as possible.
- Connections between the wire supplied with the transducer, and any customer installed extension wire should only be grounded at the LUT400.

On Siemens transducers the white wire is negative and the black wire is positive. If the extension wire is colored differently, make sure that it is wired consistently.

Extension wire must be shielded twisted pair. See the installation section for specifications.

### 11.5.4 Reducing Electrical Noise

- Ensure that the transducer cable does not run parallel to other cables carrying high voltage or current.
- Move the transducer cable away from noise generators like variable speed drives.
- Put the transducer cable in grounded metal conduit.
- Filter the noise source.
- Check grounding.

### 11.5.5 Reducing Acoustical Noise

- Move the transducer away from the noise source.
- Use a stilling well.
- Install a rubber or foam bushing or gasket between the transducer and the mounting surface.
- Relocate or insulate the noise source.
- Change the frequency of the noise. Ultrasonic devices are sensitive to noise in the frequency range of the transducer employed.
- Check that transducer is not mounted too tightly; only hand-tight.

## 11.6 Measurement Difficulties

If the LOE Timer (2.4.2.) (Page 179) expires due to a measurement difficulty, the Fail-Safe mA Value (2.4.3.) (Page 179) displays. In rare cases, the SITRANS LUT400 may lock on to a false echo and report a fixed or wrong reading.

## 11.6.1 Loss of Echo (LOE)

The Fail-Safe mA Value (2.4.3.) (Page 179) (seen in Current Output Value (2.5.8.) (Page 183)) when the echo confidence is below the threshold value set in Echo Threshold (2.12.2.2.) (Page 224).

### 11.6.1.1 LOE occurs when:

- The echo is lost and no echo is shown above the ambient noise (see Confidence (3.2.9.2.) (Page 249) and Echo Strength (3.2.9.3.) (Page 250))
- Two echoes are too similar to differentiate (when BLF algorithm used) (see Confidence (3.2.9.2.) (Page 249) and Echo Strength (3.2.9.3.) (Page 250))
- No echo can be detected within the programmed range (see Far Range (2.2.5.) (Page 177))

### 11.6.1.2 If 2.4.3. Fail-Safe mA Value is displayed, check the following:

- Surface monitored is within the transducer maximum range
- Transducer (2.1.6.) (Page 174) model matches the transducer used
- Transducer is located and aimed properly
- Transducer (that is installed without a submergence shield) is not submerged.

## 11.6.2 Adjust Transducer Aiming

See the transducer manual for range, mounting, and aiming details. For optimum performance, adjust transducer aiming to provide the best Confidence (3.2.9.2.) (Page 249) and Echo Strength (3.2.9.3.) (Page 250) for all material levels within the measurement range.

### Displaying Echoes

The most efficient method of checking echoes is locally via the LUI, or remotely using SIMATIC PDM, AMS, FC375/475, or DTM software.

Use LUI or remote software to graphically display the echo profile at the installation. Interpret the echo profile and change relevant parameters. For LUI, see Requesting an Echo Profile (Page 78) , and for details on how to interpret an Echo Profile, see Echo Processing (Page 295).

## 11.6.3 Increase Fail-safe Timer Value

Increase the LOE Timer (2.4.2.) (Page 179) value, if fail-safe operation will not be compromised by the larger value.

Try this only if LOE exists for short periods of time.

#### 11.6.4 Install a Transducer with a Narrower Beam

A consistent, incorrect level reading may result due to interference echoes from the sides of a vessel. If this occurs, try installing a longer range (narrower beam) transducer, enter the new Transducer (2.1.6.) (Page 174) model, and (if necessary) optimize aiming and frequency again.

Always contact Siemens service personnel before selecting a transducer to solve this type of problem.

### 11.7 Fixed Reading

If the Reading is a fixed value, regardless of the transducer to material surface distance, ensure the:

1. Transducer acoustic beam is free from obstruction.
2. Transducer is properly aimed
3. Transducer is not in contact with any metal object.
4. Material mixer (if used) is operating while the SITRANS LUT400 is operating. If it is stopped, ensure that the mixer blade is not stopped under the transducer.

#### 11.7.1 Obstructions in the Sound Beam

Check for (and remove if present) any acoustic beam obstruction, or relocate the transducer.

If an obstruction cannot be removed or avoided, adjust the Time Varying Threshold (TVT) curve to reduce the Echo Confidence derived from the sound reflected by the obstruction. Use SIMATIC PDM to adjust the TVT curve. (See TVT Shaper (2.12.4.) (Page 229) under Echo Profile Utilities in LUT400 Communications manual<sup>1</sup>.)

<sup>1</sup> Communications for SITRANS LUT400 (HART) Manual (7ML19985NE01)

#### 11.7.2 Nozzle Mountings

If the transducer is mounted on or in a nozzle, grind smooth any burrs or welds on the inside or open end (the end that opens into the vessel). If the problem persists, install a larger diameter or shorter length nozzle, bevel the inside of the bottom end, or cut the open end of the nozzle at a 45° angle.

See the transducer manual for complete mounting instructions.

If the mounting hardware is over tightened, loosen it. Over tightening changes the resonance characteristics of the transducer and can cause problems.

### 11.7.3 Set the SITRANS LUT400 to Ignore the Bad Echo

If the preceding remedies have not fixed the problem, the false echo has to be ignored.

#### 11.7.3.1 If the Echo is Close to the Transducer

If there is a static, incorrect, high level reading from the SITRANS LUT400 there is probably something reflecting a strong echo back to the transducer. If the material level never reaches that point extend the Near Range (2.2.4.) (Page 176) to a distance to just past the obstruction.

#### 11.7.3.2 Adjust the TVT to Ignore the Echo

Use Auto False Echo Suppression (2.12.3.1.) (Page 227). If this does not correct the problem, use TVT Shaper (2.12.4.) (Page 229) to manually shape around false echoes.

## 11.8 Wrong Reading

If the Reading is erratic, or jumps to some incorrect value periodically, ensure the:

1. Surface monitored is not beyond the SITRANS LUT400's programmed range or the transducer's maximum range.
2. Material is not falling into the transducer's acoustic beam.
3. Material is not inside the blanking distance (near range) of the transducer.

### 11.8.1 Types of Wrong Readings

If a periodic wrong Reading is always the same value, see Fixed Reading (Page 284).

If the wrong Reading is random, ensure the distance from the transducer to the material surface is less than Far Range (2.2.5.) (Page 177) value plus one meter (i.e. ensure you are still within the measurement range programmed in the device). If the material/object monitored is outside this range, increase Far Range (2.2.5.) (Page 177) as required. This error is most common in OCM applications using weirs.

### 11.8.2 Liquid Splashing

If the material monitored is a liquid, check for splashing in the vessel. Enter a lower Response Rate value (see Quick Start (Page 59)) to stabilize the Reading, or install a stilling well. (Contact Siemens representative.)

### 11.8.3 Adjust the Echo Algorithm

Use SIMATIC PDM to view echo profiles and make adjustments to the Algorithm parameter. See Algorithm (2.12.2.1.) (Page 224).

If the "TRACKER" algorithm is used and narrow noise spikes are evident on the Echo Profile, widen the Narrow Echo Filter (2.12.2.4.) (Page 225). Also, if the true echo has jagged peaks, use Reform Echo (2.12.2.3.) (Page 225).

If multiple echoes appear on the Echo Profile, typical of a flat material profile (especially if the vessel top is domed), use the "TF" (True First) algorithm.

Should a stable measurement still not be attainable, contact Siemens representative.

## 11.9 Transducer Ringing

If the transducer is mounted too tightly, or if it is mounted so that its side touches something (such as a vessel wall, or standpipe), its resonance characteristics change and this can cause problems. Hand tighten only. PTFE tape is not recommended as it reduces friction resulting in a tighter connection that can lead to ringing.

### 11.9.1 Normal Ring Down

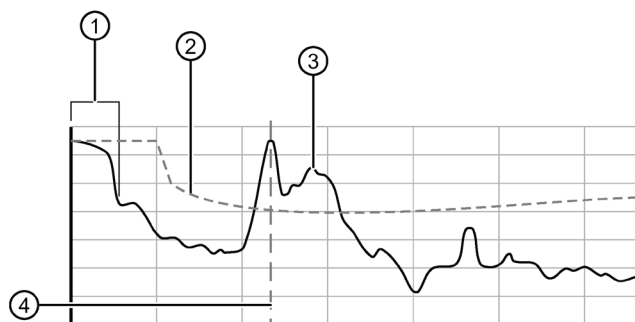

- ① Ring down
- ② TVT Curve
- ③ Echo profile
- ④ Time of correct echo

## 11.9.2 Poor Ring Down

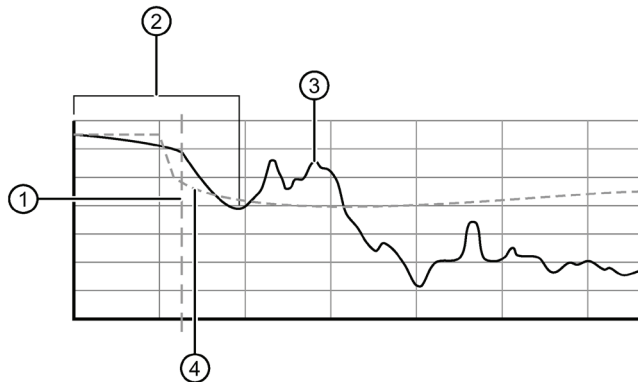

- ① Time of correct echo
- ② Ring down
- ③ Echo profile
- ④ TVT Curve

Ring down times that extend past the near range area can be interpreted by the SITRANS LUT400 as the material level and are characterized by a steady high level being reported.

## 11.10 Echo Profile Display

To assist in troubleshooting echo profiles, pan and zoom options are available. See Requesting an Echo Profile (Page 78).

## 11.11 Trend Display

A trend display is available with pan and zoom options. See Trends (Page 153).

## Technical data

### 12.1 Power

AC model	<ul style="list-style-type: none"> <li>100-230 V AC <math>\pm 15\%</math>, 50 / 60 Hz, 36 VA (10W)<sup>1)</sup></li> <li>Fuse: 5 x 20 mm, Slow Blow, 0.25A, 250V</li> </ul>
DC model	<ul style="list-style-type: none"> <li>10-32 V DC, 10W (power consumption is listed at maximum)</li> <li>Fuse: 5 x 20 mm, Slow Blow, 1.6A, 125V</li> </ul>

### 12.2 Performance

<b>Range</b>	
	<ul style="list-style-type: none"> <li>0.3 to 60 m (1 to 196 ft), dependent on transducer</li> </ul>
<b>Accuracy (measured under Reference Conditions similar to IEC 60770-1)</b>	
	<ul style="list-style-type: none"> <li>Standard operation: <math>\pm 1</math> mm (0.04") plus 0.17 % of distance</li> <li><math>\pm 3</math> mm (0.12 inch) in combination with an XRS-5 transducer on 4 m (13 ft) range or less</li> <li>High accuracy OCM<sup>1)</sup>: <math>\pm 1</math> mm (0.04"), within 3 m (9.84 ft) range</li> </ul>
<b>Resolution (measured under Reference Conditions similar to IEC 60770-1)</b>	
	<ul style="list-style-type: none"> <li>Standard operation: 0.1 % of range or 2 mm (0.08"), whichever is greater</li> <li>High accuracy OCM<sup>1)</sup>: 1 mm (0.04")<sup>2)</sup>, within 3 m (9.84 ft) range</li> </ul>
Reference operating conditions according to IEC 60770-1	
	<ul style="list-style-type: none"> <li>ambient temperature +15 to +25 °C (+59 to +77 °F)</li> <li>humidity 45% to 75% relative humidity</li> <li>ambient pressure 860 to 1060 mbar g (86 000 to 106 000 N/m<sup>2</sup> g)</li> </ul>
<b>Temperature compensation</b>	
	Range: -40 to +150 °C (-40 to +300 °F)
<b>Source</b>	
	<ul style="list-style-type: none"> <li>Integral transducer sensor</li> <li>TS-3 temperature sensor</li> <li>Average (integral transducer and TS-3)</li> <li>Programmable fixed temperature</li> </ul>
<b>Temperature error</b>	
Fixed	0.17 % per °C deviation from programmed value
<b>Memory</b>	
	<ul style="list-style-type: none"> <li>512 kB flash EPROM</li> <li>1.5 MB flash for data logging</li> </ul>



<sup>1)</sup> A high accuracy configuration consists of the LUT440 (OCM) model using XRS-5 transducer, TS-3 temperature sensor, and a Low Calibration Point of 3 m or less. Under severe EMI/EMC environments per IEC 61326-1 the DC powered device may have an additional error increase of up to 0.5 mm.

<sup>2)</sup> Achieved with a 100 µs shot width.

## 12.3 Interface

Outputs	
	mA analog
	<ul style="list-style-type: none"> <li>• 4-20 mA<sup>1)</sup></li> <li>• 600 ohms maximum in ACTIVE mode, 750 ohms maximum in PASSIVE mode</li> <li>• Resolution of 0.1%</li> <li>• Isolated</li> </ul>
	Relays <sup>2)</sup> (3)
	<ul style="list-style-type: none"> <li>• 2 control</li> <li>• 1 alarm control</li> </ul>
	Control relays
	<ul style="list-style-type: none"> <li>• 2 Form A (SPST), NO relays</li> <li>• Rated 5A at 250 V AC, non-inductive</li> <li>• Rated 3A at 30 V DC</li> </ul>
	Alarm relay
	<ul style="list-style-type: none"> <li>• 1 Form C (SPDT), NO or NC relay</li> <li>• Rated 1A at 250 V AC, non-inductive</li> <li>• Rated 3A at 30 V DC</li> </ul>
Inputs	
	Discrete (2)
	<ul style="list-style-type: none"> <li>• 0-50 V DC maximum switching level</li> <li>• Logical 0 = &lt; 10 V DC</li> <li>• Logical 1 = 10 to 50 V DC</li> <li>• 3 mA maximum draw</li> </ul>
Programming	
	Primary
	Local push buttons
	Secondary
	<ul style="list-style-type: none"> <li>• PC running SIMATIC PDM</li> <li>• PC running Emerson AMS Device Manager</li> <li>• PC running a web browser</li> <li>• PC running a Field Device Tool (FDT)</li> <li>• Field Communicator 375/475 (FC375/FC475)</li> </ul>

<b>Compatible transducers</b>	
	EchoMax series and STH series
<b>Transducer frequency</b>	
	10 to 52 kHz
<b>Communication</b>	
	<ul style="list-style-type: none"> <li>• HART 7.0</li> <li>• USB</li> </ul>
<b>Display</b>	
	<ul style="list-style-type: none"> <li>• Back-lit LCD</li> <li>• Dimensions: –60 x 40 mm (2.36 x 1.57")</li> <li>• Resolution: –240 x 160 pixels</li> <li>• Removable display, operational up to 5 m from enclosure base</li> </ul>

1) Device may output a high current reading when power is applied or removed.

2) All relays are certified only for use with equipment that fails in a state at or under the rated maximums of the relays.

## 12.4 Mechanical

<b>Enclosure</b>	
	<ul style="list-style-type: none"> <li>• 144 mm (5.7") x 144 mm (5.7") x 146 mm (5.75")</li> <li>• IP65 / Type 4X / NEMA 4X</li> <li>• Polycarbonate</li> </ul>
<b>Remote display lid</b>	
	<ul style="list-style-type: none"> <li>• 144 mm (5.7") x 144 mm (5.7") x 22 mm (0.87")</li> <li>• IP65 / Type 3 / NEMA 3</li> <li>• Polycarbonate</li> <li>• Operational up to 5 m from enclosure base</li> </ul>
<b>Blank lid</b>	
	<ul style="list-style-type: none"> <li>• 144 mm (5.7") x 144 mm (5.7") x 22 mm (0.87")</li> <li>• IP65 / Type 4X / NEMA 4X</li> <li>• Polycarbonate</li> </ul>

 <b>WARNING</b>
<p><b>Ingress protection reduced</b></p> <ul style="list-style-type: none"> <li>• Ingress protection of the enclosure is reduced to IP20, and Type 4X / NEMA 4X rating is void when cable entry knock-out in the blank lid is removed.</li> <li>• An enclosure reduced to an IP20 rating and intended for use in nonhazardous locations must be installed in an indoor location free of dust and moisture, or be installed in a suitably rated field enclosure IP54 or better.</li> </ul>

<b>Back mount bracket</b>	
	<ul style="list-style-type: none"> <li>• 190 mm (7.5") x 190 mm (7.5") x 9 mm (0.35")</li> <li>• Polycarbonate</li> </ul>
<b>Weight</b>	
	<ul style="list-style-type: none"> <li>• Enclosure with display lid: 1.3 kg (2.87 lbs)</li> <li>• Enclosure with blank lid: 1.2 kg (2.65 lbs)</li> </ul>

## 12.5 Environmental

Location	Indoor / outdoor (only suitable for outdoor use with IP65 / Type 4X / NEMA 4X Enclosure)
Altitude	2000 m max.
Ambient temperature	-20 to +50 °C (-4 to +122 °F)
Relative humidity	Suitable for outdoors (only with IP65 / Type 4X / NEMA 4X Enclosure)
Installation category	II
Pollution degree	4

## 12.6 Approvals

### Note

The device nameplate lists the approvals that apply to your device.

General	CSA <sub>US/IC</sub> , CE, FM, UL listed, C-TICK
Hazardous	<ul style="list-style-type: none"> <li>• Non-incendive (Canada)</li> <li>• CSA Class I, Div. 2, Groups A, B, C, D; Class II, Div 2, Groups F, G; Class III</li> </ul>

## Dimension drawings

### 13.1 SITRANS LUT400 Dimensions

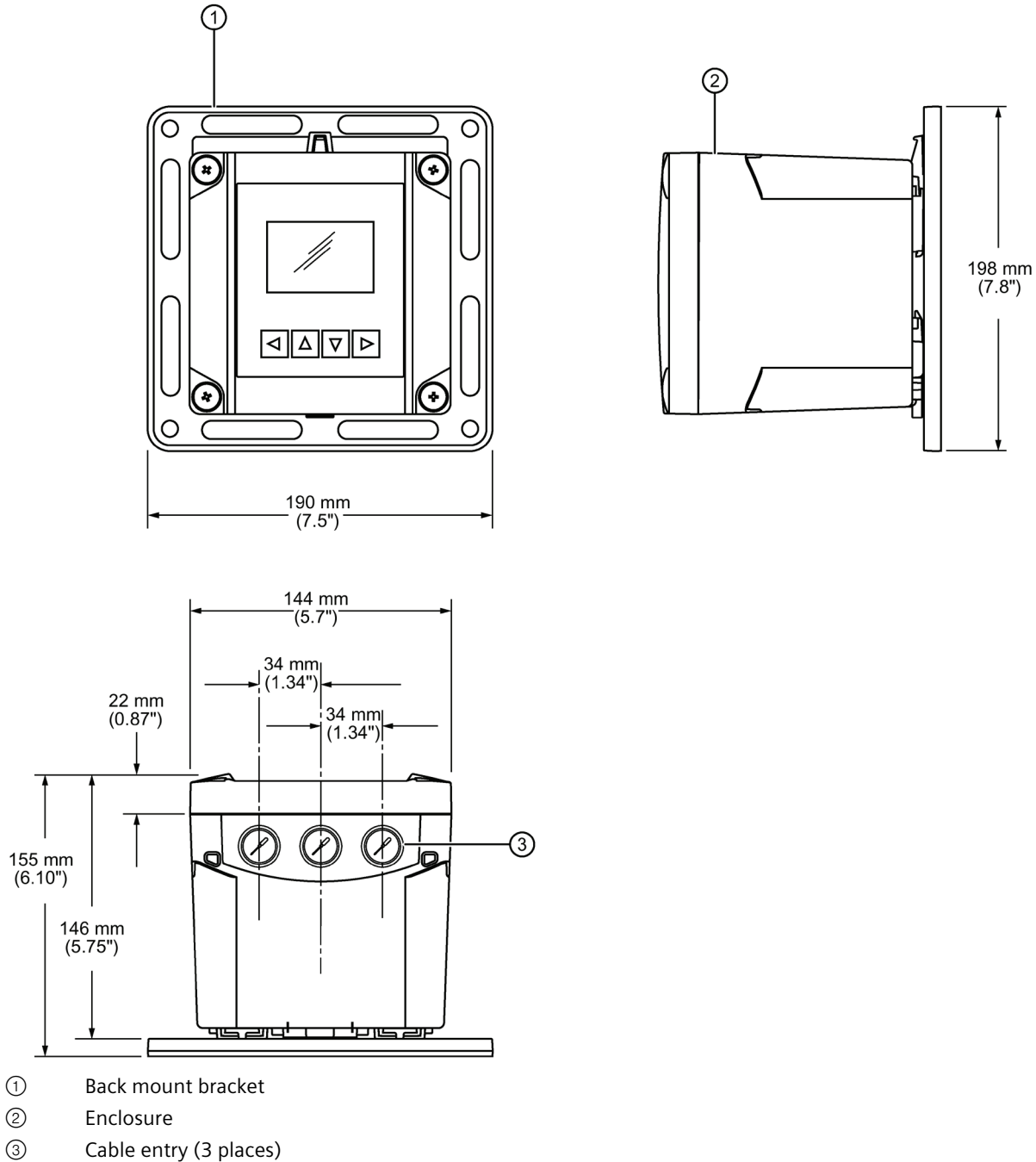

## 13.2 Cutout Dimensions (for Remote Panel Mount)

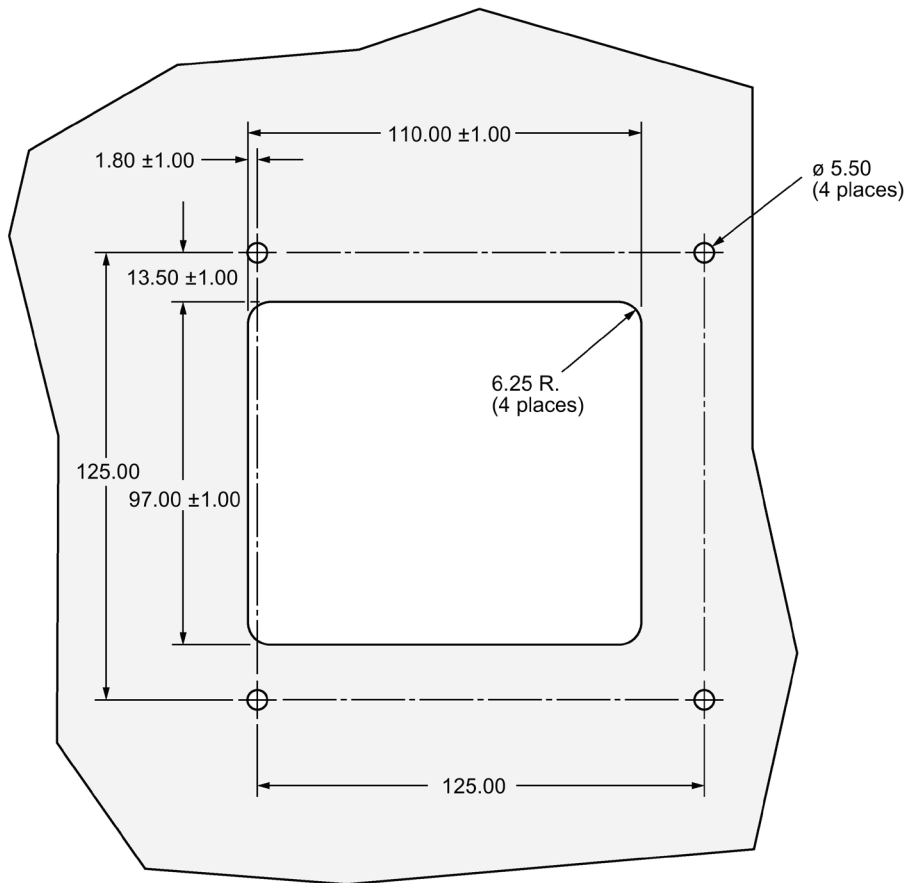

### Note

Cut-out template (printed to scale) shipped with remote panel mount model.

## A.1 Principles of Operation

The SITRANS LUT400 is a high quality ultrasonic controller, configured to meet the needs of different applications, from medium range solids applications to liquids management with open channel measurement capability. The LUT400 features our next generation of Sonic Intelligence® advanced echo-processing software for increased reading reliability.

---

### Note

Where a number precedes a parameter name (for example, Narrow Echo Filter (2.12.2.4.) (Page 225)) this is the parameter access number via the local display. See Parameter reference (LUI) (Page 171) for a complete list of parameters.

---

### A.1.1 Process Variables

The Primary Variable (PV) is one of six process variables, and is set in Current Output Function (2.5.1.) (Page 180).

- Level (difference between material level and Low Calibration Point),
- Space (difference between material level and High Calibration Point),
- Distance (difference between material level and sensor reference point),
- Head (difference between liquid level and Zero Head),
- Volume (volume of material based on level),
- Flow (flowrate in an open channel, based on head).

### A.1.2 Transmit Pulse

The transmit pulse consists of one or more electrical “shot” pulses, which are supplied to the transducer connected to the SITRANS LUT400 terminals. The transducer fires an acoustic “shot” for each electrical pulse supplied. After each shot is fired, sufficient time is provided for echo (shot reflection) reception before the next (if applicable) shot is fired. After all shots of the transmit pulse are fired, the resultant echoes are processed. The transmit pulse frequency, duration, delay, and associated measurement range are defined by parameters in the Setup menu (see Setup (2.) (Page 172))

## A.2 Echo Processing

SITRANS LUT400 uses next generation Sonic Intelligence® for echo processing.

Next generation Sonic Intelligence provides adaptive digital filtering of the transducer signal. For example, when noise levels are high, filters are adjusted to maximize the signal to noise ratio. This advanced Sonic Intelligence not only allows for better filtering, but provides improved tracking of echoes, and more sophisticated echo positioning algorithms.

Echo processing consists of echo enhancement, true echo selection, and selected echo verification.

Echo enhancement is achieved by filtering (Narrow Echo Filter (2.12.2.4.) (Page 225)) and reforming (Reform Echo (2.12.2.3.) (Page 225)) the echo profile.

True echo selection (selection of echo reflected by the intended target) occurs when that portion of the echo profile meets the evaluation criteria of Sonic Intelligence.

Insignificant portions of the echo profile outside of the measurement range (Low Calibration Point (2.2.1.) (Page 176)), below the TVT curve (TVT Shaper (2.12.4.) (Page 229)) are automatically disregarded. The remaining portions of the Echo Profile are evaluated using the echo select algorithm (Algorithm (2.12.2.1.) (Page 224)), and the Echo Profile portion providing the best echo confidence (Confidence (3.2.9.2.) (Page 249)) is selected.

A confidence value is a static test of a single snapshot profile so to maintain a valid reading, it imposes that each individual profile show its peak above the threshold. The window may be locked on the profile for hours or days so if the profile drops below the TVT curve just once, a loss of echo may occur

The SITRANS LUT400, with its advanced tracking ability, can find and track the real echo amongst stationary clutter echoes. Therefore, even if the echo drops below the tvt curve, it can be identified with near certainty for approximately 30 seconds. This capability is measured by the FOM (Figure of Merit (3.2.9.1.) (Page 249)).

Selected echo verification is automatic. The position (relation in time after transmit) of the new echo is compared to that of the previously accepted echo. When the new echo is within the Echo Lock Window, it is accepted and displays, outputs, and relays are updated. If the new echo is outside of the Window, it is not accepted until Echo Lock requirements are satisfied.

### A.2.1 Echo Selection

#### A.2.1.1 Time Varying Threshold (TVT)

A TVT curve describes a threshold below which any echoes will be ignored. The default TVT curve is used, until Auto False Echo Suppression (2.12.3.1.) (Page 227) and Auto False Echo Suppression Range (2.12.3.2.) (Page 228) are used to create a new 'learned TVT curve'.

A TVT hovers above the echo profile to screen out unwanted reflections (false echoes).

In most cases the material echo is the only one which rises above the default TVT.

In a vessel with obstructions, a false echo may occur. See Shaper Mode and Auto False Echo Suppression (Page 297) below for more details.

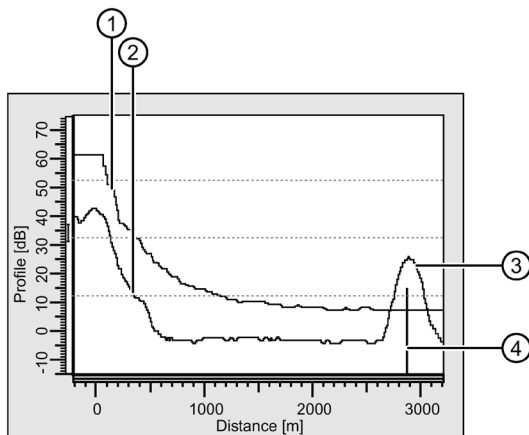

- ① Default TVT
- ② Echo Profile
- ③ Material level
- ④ Echo marker

The device characterizes all echoes that rise above the TVT as potential good echoes. Each peak is assigned a rating based on its strength, area, height above the TVT, and reliability, amongst other characteristics.

### A.2.1.2 Algorithm

The true echo is selected based on the setting for the Echo selection algorithm. For a list of options see Algorithm (2.12.2.1.) (Page 224). All algorithms ultimately use confidence to select the true echo. However, when applications report a low confidence value, the TR algorithm (which tracks the moving echo) can be used to predict the primary variable.

Algo-rithm		Echo Determination	Suggested Usage
TF	True First echo	Selects the first echo that crosses TVT curve.	Use in liquids applications free of obstructions when confidence of first echo is high.
TR	TRacker	Selects the echo that is closest to the transducer, and is moving. (If echo location is steady, BLF algorithm should be used.)	Only use TR algorithm in process applications with continuous level changes, and a risk of fixed obstructions that could interfere with true level, resulting in low confidence.
L	Largest echo	Selects the largest echo above the TVT curve.	Use in long range liquids applications with large (tall) material return echoes.
BLF	Best of First and Largest echo	Selects the echo (first and highest) with the highest confidence value.	Default and most commonly used. Use in all short to mid range general liquids and solids applications where there is a relatively large (tall), sharp echo.
ALF	Area, Largest, and First	Selects the echo with the highest confidence value based on the three criterion (widest, highest, and first).	Use in mid to long range solids applications where the material return echo is wide and large, and where competing smaller echoes challenge BLF.



### A.2.1.3 Confidence

Confidence (3.2.9.2.) (Page 249) describes the quality of an echo. Higher values represent higher quality.

### A.2.1.4 Echo Threshold

Echo Threshold (2.12.2.2.) (Page 224) defines the minimum confidence value required for an echo to be accepted as valid and evaluated.

### A.2.1.5 Figure of Merit

Figure of Merit (3.2.9.1.) (Page 249) measures the quality of the reported process value: higher values represent better quality. Even when a low confidence value exists, a high FOM will ensure the true echo has been selected. Approximately 20 readings are used to support the FOM value.

#### Example:

FOM greater than 75% = good quality,

FOM less than 50% = poor quality.

Various things contribute to the FOM:

- success of the tracking (how closely can the next level vs. the actual next level be predicted)
- level of noise
- confidence of the last echo
- time interval since last valid echo
- speed at which the process is moving
- quality of the echo shape and how it helps the calculation of the echo position

If FOM is low, reduce the noise in the process, or check the installation to increase signal quality.

## Shaper Mode and Auto False Echo Suppression

---

### Note

- For detailed instructions on using this feature via PDM, see Auto False Echo Suppression in LUT400 Communications manual<sup>1</sup>.
  - For detailed instructions on using this feature via the local push buttons, see Shaper Mode (2.12.3.4.) (Page 228).
- 

<sup>1</sup>) Communications for SITRANS LUT400 (HART) Manual (7ML19985NE01)

False echoes can be caused by an obstruction in the transducer shot path (such as pipes, ladders, chains). Such false echoes may rise above the default TVT curve.

Auto False Echo Suppression Range (2.12.3.2.) (Page 228) specifies the range within which the learned TVT is applied. Default TVT is applied over the remainder of the range.

The material level should be below all known obstructions at the moment when Auto False Echo Suppression learns the echo profile. Ideally the vessel should be empty or almost empty.

The device learns the echo profile over the whole measurement range and the TVT is shaped around all echoes present at that moment.

Auto False Echo Suppression Range must be set to a distance shorter than the distance to the material level when the environment was learned, to avoid the material echo being screened out.

**Example before Auto False Echo Suppression**

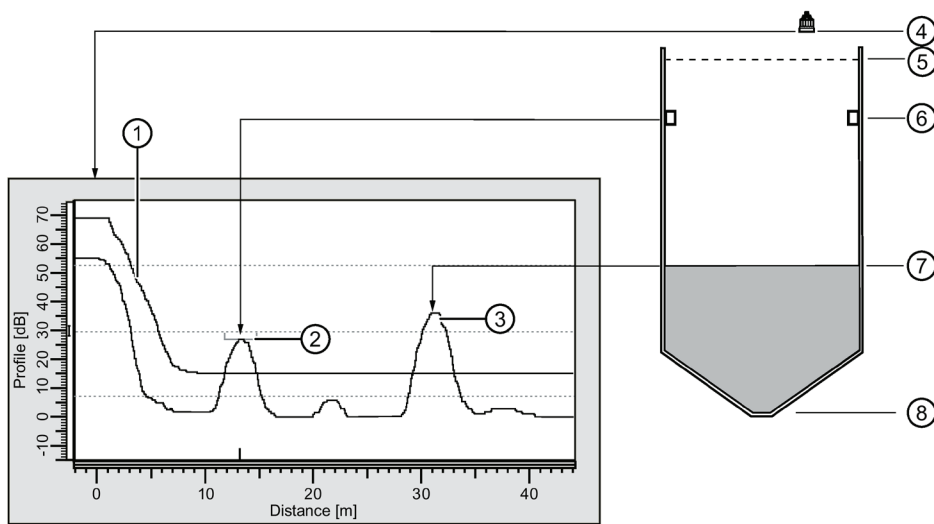

- ① Default TVT
- ② False echo
- ③ Material echo
- ④ Sensor reference point
- ⑤ High calibration point = 1 m
- ⑥ Obstruction at 13 m
- ⑦ Material level at 31 m
- ⑧ Low calibration point = 45 m

### Example after Auto False Echo Suppression

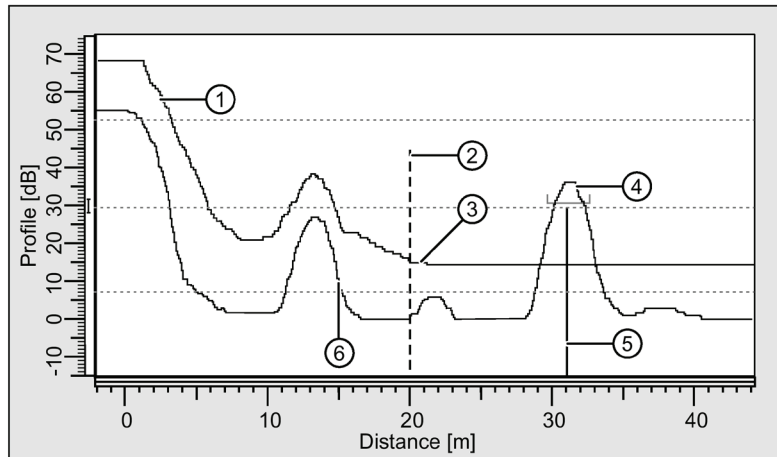

- ① Learned TVT
- ② Auto False Echo Suppression Range
- ③ Default TVT
- ④ Material echo
- ⑤ Echo marker
- ⑥ False echo

## A.2.2 Measurement Range

### Near Range

Near Range (2.2.4.) (Page 176) programs SITRANS LUT400 to ignore the area in front of the transducer. The default blanking distance is 27.8 cm (0.91 ft) from the sensor reference point.

Near Range allows you to increase the blanking value from its factory default. But Shaper Mode (2.12.3.4.) (Page 228) is generally recommended in preference to extending the blanking distance from factory values.

### Far Range

Far Range (2.2.5.) (Page 177) can be used in applications where the base of the vessel is conical or parabolic. A reliable echo may be available below the vessel empty distance, due to an indirect reflection path.

Increasing Far Range by 30% or 40% can provide stable empty vessel readings.

### A.2.3 Measurement Response

---

**Note**

Units are defined in Units (2.1.1.) (Page 172) and are in meters by default.

---

Response Rate limits the maximum rate at which the display and output respond to changes in the measurement. There are three preset options: slow, medium, and fast.

Once the real process fill/empty rate (m/min by default) is established, a response rate can be selected that is slightly higher than the application rate. Response Rate automatically adjusts the three rate parameters that affect the output response rate.

When Response Rate set to:	Fill Rate per Minute (2.3.1.) (Page 178)/Empty Rate per Minute (2.3.2.) (Page 178) automatically adjust to:	Damping Filter (2.3.3.) (Page 178) automatically adjust to:
* <b>Slow</b>	0.1 m/min	100.0 s
<b>Medium</b>	1.0 m/min	10.0 s
<b>Fast</b>	10.0 m/min	0.0 s

#### A.2.3.1 Damping

Sensor Offset (2.2.3.) (Page 176) smooths out the response to a sudden change in level. This is an exponential filter and the engineering unit is always in seconds.

In 5 time constants, the output rises exponentially: from 63.2% of the change in the first time constant, to almost 100% of the change by the end of the 5th time constant.

**Damping example:**

time constant = 2 seconds

input (level) change = 2 m

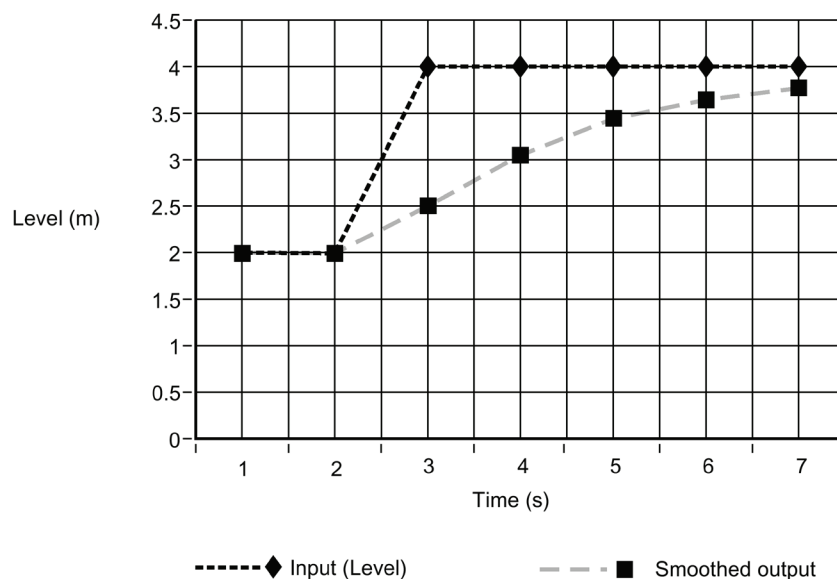

**Note**

Damping Filter can be set to 0 in order to display measurement readings as fast as fill/empty rates permit. Fill Rate per Minute, and Empty Rate per Minute work in conjunction with Damping Filter, therefore, if readings are slow to respond to changes, check that Fill and Empty Rates are set to values greater than or equal to the desired Response Rate.

## A.3 Analog Output

The mA output (current output) is proportional to material level in the range 4 to 20 mA. 0% and 100% are percentages of the full-scale reading (m, cm, mm, ft, in). Typically mA output is set so that 4 mA equals 0% and 20 mA equals 100%.

### A.3.1 Current Output Function (2.5.1.)

Current Output Function (2.5.1.) (Page 180) controls the mA output and applies any relevant scaling. By default it is set to LEVEL. Other options are Space, Distance, Volume, Head, Flow, or Manual. A MANUAL setting allows you to test the functioning of the loop.

You can also set the mA output to report when the device is in an error condition and the fail-safe timer has expired. By default, the reported value depends on the device type. A standard device reports the last valid reading, and a NAMUR NE43 compliant device reports the user-defined value for Material Level (2.4.1.) (Page 179) (3.58 mA by default).

### A.3.2 Loss of Echo (LOE)

A loss of echo (LOE) occurs when the calculated measurement is judged to be unreliable because the echo confidence value has dropped below the echo confidence threshold.

If the LOE condition persists beyond the time limit set in LOE Timer (2.4.2.) (Page 179) the LCD displays the Service Required icon, and the text region displays the fault code 0 and the text LOE.

If two faults are present at the same time, the device status indicator and text for the highest priority fault will display. For example, if both Loss of Echo and Broken cable faults are present, the Broken cable fault will display.

#### A.3.2.1 Fail-safe Mode

The purpose of the Fail-safe setting is to put the process into a safe mode of operation in the event of a fault or failure. The value to be reported in the event of a fault (as displayed in Current Output Value (2.5.8.) (Page 183)) is selected so that a loss of power or loss of signal triggers the same response as an unsafe level.

LOE Timer (2.4.2.) (Page 179) determines the length of time a Loss of Echo (LOE) condition will persist before a Fail-safe state is activated. The default setting is 100 seconds.

Material Level (2.4.1.) (Page 179) determines the mA value (corresponding to the selected PV) to be reported when LOE Timer (2.4.2.) (Page 179) expires. The default setting is device dependent (standard or NAMUR NE 43-compliant).

Upon receiving a reliable echo, the loss of echo condition is aborted, the Maintenance Required icon and error message are cleared, and the mA output return to the current material level. [The PV region on the LUI display will show dashes (-----) when a fault that causes fail-safe is present, and will return to the current reading when the fault is cleared.]

## A.4 Distance Calculation

To calculate the transducer to material level (object) distance, the transmission medium (atmosphere) Sound Velocity (2.12.1.1.) (Page 222) is multiplied by the acoustic transmission to reception time period. This result is divided by 2 to calculate the one way distance.

$$\text{Distance} = \text{Sound Velocity} \times \text{Time} / 2$$

The Reading displayed is the result of performing any additional modification to the calculated distance as determined by:

- Sensor Offset (2.2.3.) (Page 176),
- Units (2.1.1.) (Page 172),
- Volume conversion parameters - Volume (2.6.) (Page 184), Sensor Offset (2.2.3.) (Page 176),
- Flow parameters - Flow (2.15.) (Page 234),
- and/or Totalizer parameters - Totalizers (2.16.) (Page 242).

### A.4.1 Sound Velocity

The sound velocity of the transmission medium is affected by the type, temperature, and vapor pressure of the gas or vapor present. As preset, the SITRANS LUT400 assumes the vessel atmosphere is air at +20 °C (+68 °F). Unless altered, the sound velocity used for the distance calculation is 344.1 m / s (1129 ft / s).

Variable air temperature is automatically compensated when a Siemens ultrasonic / temperature transducer is used. If the transducer is exposed to direct sunlight, use a sunshield or a separate TS-3 temperature sensor.

Also, if the temperature varies between the transducer face and the liquid monitored, use a TS-3 temperature sensor in combination with an ultrasonic / temperature transducer. The TS-3 must be installed as close to the material as possible to ensure best performance. It is acceptable to submerge the TS-3 if necessary. Set Temperature Source (2.12.1.3.) (Page 222) for Average of Sensors, to average the transducer and TS-3 measurements.

Atmosphere composition other than air can pose a challenge for ultrasonic level measurement. However, excellent results may be obtained if the atmosphere is homogeneous (well mixed), at a fixed temperature, and consistent vapour pressure, by performing a Auto Sound Velocity (2.12.1.6.) (Page 223) .

The SITRANS LUT400 automatic temperature compensation is based on the sound velocity / temperature characteristics of "air" and may not be suitable for the atmosphere present. If the atmosphere temperature is variable, perform frequent sound velocity calibrations to optimize measurement accuracy.

Sound velocity calibration frequency may be determined with experience. If the sound velocity in two or more vessels is always similar, future calibrations may be performed on one vessel and the resultant Sound Velocity (2.12.1.1.) (Page 222) entered directly for the other vessel(s).

If the sound velocity of a vessel atmosphere is found to be repeatable at specific temperatures, a chart or curve may be developed. Then rather than performing a sound velocity calibration each time the vessel temperature changes significantly, the anticipated Sound Velocity (2.12.1.1.) (Page 222) may be entered directly.

## A.5 Volume Calculation

The SITRANS LUT400 provides a variety of volume calculation features (see Volume (2.6.) (Page 184)).

If the vessel does not match any of the eight preset vessel shape calculations, a Universal Volume calculation may be used. Use the level/volume graph or chart provided by the vessel fabricator (or create one based on the vessel dimensions). Based on the graph, choose the Universal Volume calculation, and select the level vs. volume breakpoints to be entered (32 max). Generally, the more breakpoints entered, the greater the accuracy.

### 2.6.1.Vessel Shape set to Universal, Linear

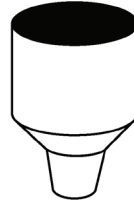
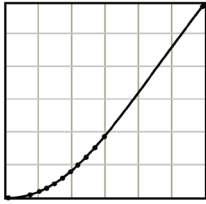

This volume calculation creates a piece-wise linear approximation of the level/volume curve. This option provides best results if the curve has sharp angles joining relatively linear sections.

Enter a Level Breakpoint at each point where the level/volume curve bends sharply (2 minimum).

For combination curves (mostly linear but include one or more arcs), enter numerous breakpoints along the arc, for best volume calculation accuracy.

### 2.6.1.Vessel Shape set to Universal, Curved

This calculation creates a cubic spline approximation of the level/volume curve, providing best results if the curve is non-linear, and there are no sharp angles.

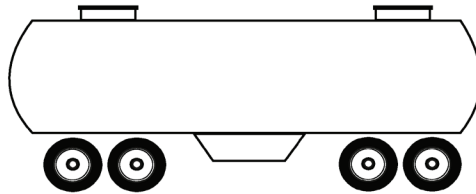
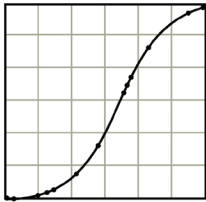

**Select at least enough breakpoints from the curve to satisfy the following:**

- two breakpoints very near the minimum level
- one breakpoint at the tangent points of each arc
- one breakpoint at each arc apex
- two breakpoints very near the maximum level

For combination curves, enter at least two breakpoints immediately before and after any sharp angle (as well as one breakpoint exactly at the angle) on the curve.



## A.6 Pump Totalizers

### A.6.1 Inflow/Discharge Adjust

Pumped volume totals are affected by the inflow (or discharge) rate. This rate can be calculated based on rate of change estimation, or pump cycle timing.

Using Inflow/Discharge Adjust (2.7.3.4.) (Page 199), set option Based on rate estimation to have the inflow rate measured just prior to the start of the pump cycle.

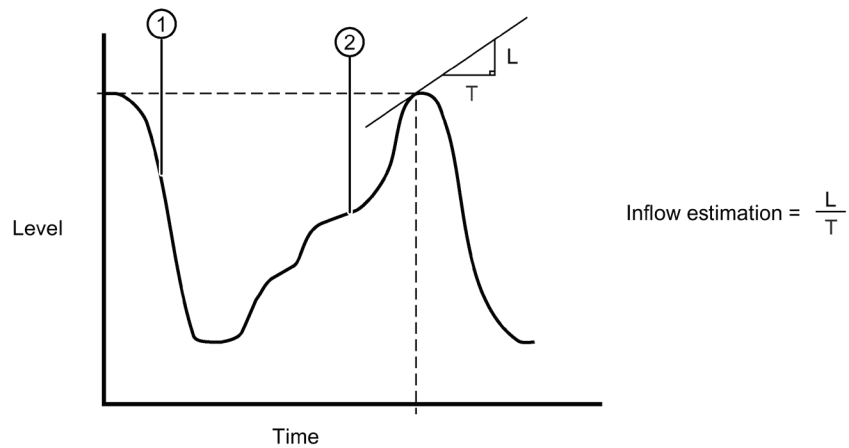

- ① Pump down
- ② Well refills

Set option Based on pump cycle to calculate the inflow based on the change of volume between the end of the last pump cycle and the start of the next one, and the time period between the last cycle and the current one.

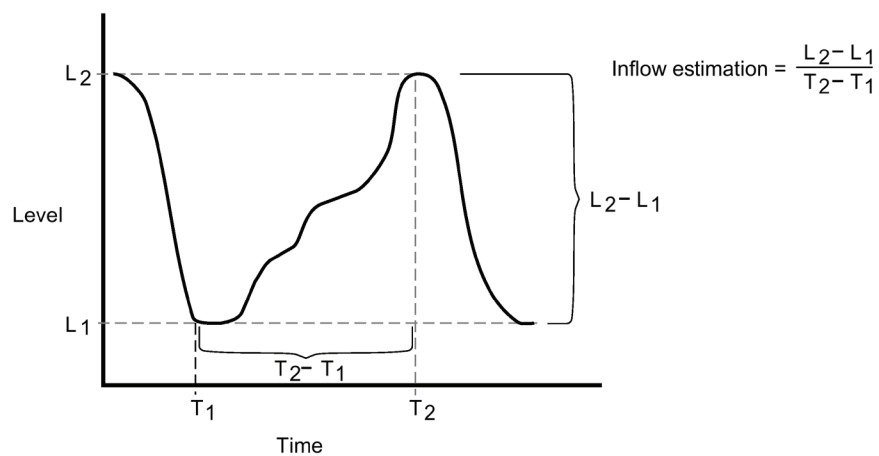

## A.7 Flow Calculation

Special emphasis has been placed on providing the most accurate flow calculations possible. To this end, specific routines have been written to comply with the British Standards Institute's Specifications BS-3680. These routines calculate correction factors taking into account second order effects such as approach velocity and boundary layer.

If the PMD does not match any of the eleven preset PMD calculations, or if a PMD is not used, select a Universal flow calculation (PMD = Universal Head Flow). Use the head/ flow graph or chart provided by the PMD fabricator (or create one based on the PMD or channel dimensions).

The SITRANS LUT400 supports Universal curved flow calculation. This calculation creates a cubic spline approximation of the head/flow curve, providing best results if the curve is non-linear, and there are no sharp angles.

Select the head versus flow breakpoints to be entered (32 max). Generally, the more breakpoints entered, the greater the flow calculation accuracy.

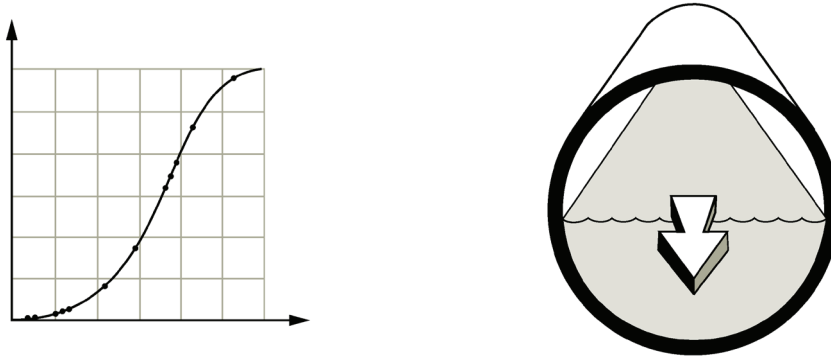

**Select at least enough breakpoints from the curve to satisfy the following:**

- two breakpoints very near the minimum head
- one breakpoint at the tangent points of each arc
- one breakpoint at each arc apex
- two breakpoints very near the maximum head

For combination curves, enter at least 2 breakpoints immediately before and after any sharp angle (as well as 1 breakpoint exactly at the angle) on the curve.

### A.7.1 Method of Flow Calculation

The SITRANS LUT400 can be programmed to use either of two methods for calculating flow from the head measurement: absolute or ratiometric. The result is the same regardless of the method used. The main difference is the information that must be entered in order for the device to carry out the calculation. Refer to Primary Measuring Device (PMD) (2.15.1.) (Page 234), and PMD Dimensions (2.15.4.) (Page 239) for list of information required.

For the ratiometric method, it is usually sufficient that the user knows the flow rate ( $Q_{cal}$ ) which occurs at maximum head ( $h_{cal}$ ).

On the other hand, absolute calculations require that the user enter information such as: the physical dimensions of the PMD and the constant relating to units of measure for both linear dimensions and flow rates.

**Example:**

the general formula for flow through a single exponent PMD is:

$$Q = KH^x$$

the specific formula for flow through a 45 ° V-notch weir is:

$$cfs = 1.03H^{2.5}$$

thus: Q = flow in cubic feet per second

K = constant of 1.03

H = head in feet

The absolute method is not applicable to the following:

- Palmer Bowlus Flume
- H-Flume

## A.7.2 Data Logging

Data logs are available for Alarms, OCM flow, Daily Totals, and Primary Variable. The logs can be examined locally via LUI (see View Logs (3.2.6.) (Page 247)), or by uploading the logs to a PC using USB and the Web Browser tool on a computer.

Using the Web Browser tool, choose menu item **Maintenance and Diagnostics > Diagnostics > Data Logs** page which displays a Load Logs button. Click this button and you will be prompted with a dialog box that allows you to choose the location on your local PC where the uploaded logs will be placed. Note that the logs uploaded at this point will replace any previous logs you may have uploaded before, so be sure to choose an empty directory here to avoid losing logs you may have uploaded in the past.

Log files written to a local computer drive via USB, are comma-delimited files, and a list of file headings for each type of log is shown below.

Log type	Headings
Alarms	Date (YYYY/MMM/DD)
	Time (HH:MM:SS)
	Alarm Name
	Value at Transition
	Transition Value Units
	Alarm State
OCM	Date (YYYY/MMM/DD)
	Time (HH:MM:SS)
	Head
	Head Units
	Flow
	Flow Units

Log type	Headings
Daily Totals	Date (YYYY/MMM/DD)
	Time (HH:MM:SS)
	Maximum Flow
	Minimum Flow
	Average Flow
	Flow Units
	Maximum Temperature
	Minimum Temperature
	Temperature Units
	Daily Total
	Running Total
	Totalizer Units
	PV
Time (HH:MM:SS)	
PV Type	
PV Value	
PV Units	
Temperature	
Temperature Units	

To clear entries when log memory becomes full, see Viewing the Data Log (Page 154).

# Product documentation and support

## B.1 Product documentation

Process instrumentation product documentation is available in the following formats:

- Certificates (<http://www.siemens.com/processinstrumentation/certificates>)
- Downloads (firmware, EDDs, software) (<http://www.siemens.com/processinstrumentation/downloads>)
- Catalog and catalog sheets (<http://www.siemens.com/processinstrumentation/catalogs>)
- Manuals (<http://www.siemens.com/processinstrumentation/documentation>)

You have the option to show, open, save, or configure the manual.

- "Display": Open the manual in HTML5 format
- "Configure": Register and configure the documentation specific to your plant
- "Download": Open or save the manual in PDF format
- "Download as html5, only PC": Open or save the manual in the HTML5 view on your PC

You can also find manuals with the Mobile app at Industry Online Support (<https://support.industry.siemens.com/cs/ww/en/sc/2067>). Download the app to your mobile device and scan the device QR code.

### Product documentation by serial number

Using the PIA Life Cycle Portal, you can access the serial number-specific product information including technical specifications, spare parts, calibration data, or factory certificates.

#### Entering a serial number

1. Open the PIA Life Cycle Portal (<https://www.pia-portal.automation.siemens.com>).
2. Select the desired language.
3. Enter the serial number of your device. The product documentation relevant for your device is displayed and can be downloaded.

To display factory certificates, if available, log in to the PIA Life Cycle Portal using your login or register.

#### Scanning a QR code

1. Scan the QR code on your device with a mobile device.
2. Click "PIA Portal".

To display factory certificates, if available, log in to the PIA Life Cycle Portal using your login or register.

## B.2 Technical support

### Technical support

If this documentation does not completely answer your technical questions, you can enter a Support Request (<http://www.siemens.com/automation/support-request>).

For help creating a support request, view this video here.

Additional information on our technical support can be found at Technical Support (<http://www.siemens.com/automation/csi/service>).

### Service & support on the Internet

In addition to our technical support, Siemens offers comprehensive online services at Service & Support (<http://www.siemens.com/automation/serviceandsupport>).

### Contact

If you have further questions about the device, contact your local Siemens representative at Personal Contact (<http://www.automation.siemens.com/partner>).

To find the contact for your product, go to "all products and branches" and select "Products & Services > Industrial automation > Process instrumentation".

Contact address for business unit:

Siemens AG

Digital Industries

Process Automation

Östliche Rheinbrückenstr. 50

76187 Karlsruhe, Germany

## List of abbreviations

Short form	Long form	Description	Units
AC	Alternating Current	power source	
AFES	Auto False Echo Suppression		
CE / FM / CSA	Conformité Européene / Factory Mutual / Canadian Standards Association	safety approval	
BS-3680	Flow standard from the British Standards Institute		
DC	Direct Current	power source	
DTM	Device Type Manager		
EDD	Electronic Device Description		
EMC	Electromagnetic Compatibility		
ESD	Electrostatic Discharge		
FCC	Federal Communications Commission		
FDT	Field Device Tool		
FOM	Figure of Merit	measurement of echo quality	
HART	Highway Addressable Remote Transducer		
HCF	Hart Communication Foundation		
IEC	International Electrotechnical Commission		
IP	Ingress Protection		
IS	Intrinsically Safe	safety approval	
LCD	Liquid Crystal Display		
LOE	Loss of Echo		
LUI	Local User Interface	view outputs via LCD display; make modifications via local push buttons	
µs	microsecond	10 <sup>-6</sup>	
µV	microvolt	10 <sup>-6</sup>	
mA	Milliamp	unit of electric current	Second
Nm	Newton meter	unit of torque	Volt
NEMA	National Electrical Manufacturer's Association		
PDM	Process Device Manager		
PLC	Programmable Logic Controller		
PV	Primary Variable	measured value	
RC	Resistance Capacitance	resistance x capacitance	µs

<b>Short form</b>	<b>Long form</b>	<b>Description</b>	<b>Units</b>
SCADA	Supervisory Control and Data Acquisition		
SCR	Silicon-controlled rectifier	switching device	
SPDT	Single Pole Double Throw	relay configuration	
SPST	Single Pole Single Throw	relay configuration	
SV	Secondary Variable	equivalent value	
TVT	Time Varying Threshold	sensitivity threshold	
USB	Universal Serial Bus		
VSDs	Variable Speed Drives		



## LCD menu structure

### 1. WIZARDS

#### 1.1 QUICK START

##### 1.1.1 QS Level

- INTRODUCTION
- TRANSDUCER
- OPERATION
- TEMPERATURE SOURCE
- FIXED TEMPERATURE
- UNITS
- HIGH CALIB. PT.
- LOW CALIB. PT.
- RESPONSE RATE
- APPLY?

##### 1.1.2 QS VOLUME

- INTRODUCTION
- TRANSDUCER
- TEMPERATURE SOURCE
- FIXED TEMPERATURE
- VESSEL SHAPE
- UNITS
- HIGH CALIB. PT.
- LOW CALIB. PT.
- RESPONSE RATE
- DIMENS. A
- DIMENS. L
- VOLUME UNITS
- MAX. VOLUME
- APPLY?

##### 1.1.3 QS FLOW (LUT430, 440 only)

- INTRODUCTION
- TRANSDUCER
- TEMPERATURE SOURCE
- FIXED TEMPERATURE
- PRIMARY MEASURING DEVICE
- METHOD OF FLOW CALCULATION
- UNITS
- HIGH CALIB. PT.
- LOW CALIB. PT.
- RESPONSE RATE

- Calculation factors (vary per PMD)
- PMD dimensions (vary per PMD)
- MAXIMUM HEAD
- ZERO HEAD OFFSET
- FLOWRATE UNITS
- MAXIMUM FLOW AT 20MA
- FLOWRATE DECIMAL
- LOW FLOW CUTOFF
- APPLY?

#### 1.2 PUMP CONTROL

- INTRODUCTION
- NUMBER OF PUMPS
- RELAY PUMP 1
- RELAY PUMP 2
- PUMP CONTROL MODE
- SERVICE RATIO PUMP 1
- SERVICE RATIO PUMP 2
- RUN TIME PUMP 1
- RUN TIME PUMP 2
- ON SETPOINT PUMP 1
- ON SETPOINT PUMP 2
- OFF SETPOINT PUMP 1
- OFF SETPOINT PUMP 2
- OFF SETPOINT PUMP 2

#### 2. SETUP

##### 2.1 SENSOR

- 2.1.1 UNITS
- 2.1.2 SENSOR MODE (LUT420)
- 2.1.3 SENSOR MODE (LUT430, 440)
- 2.1.4 SENSOR MODE SECONDARY (LUT420)
- 2.1.5 SENSOR MODE SECONDARY (LUT430, 440)
- 2.1.6 TRANSDUCER
- 2.1.7 FREQUENCY
- 2.1.8 LONG SHOT DURATION
- 2.1.9 SHORT SHOT DURATION

##### 2.2 CALIBRATION

- 2.2.1 LOW CALIB. PT.
- 2.2.2 HIGH CALIB. PT.
- 2.2.3 SENSOR OFFSET
- 2.2.4 NEAR RANGE
- 2.2.5 FAR RANGE
- 2.2.6 AUTO SENSOR OFFSET

##### 2.3 RATE

- 2.3.1 FILL RATE/MIN
- 2.3.2 EMPTY RATE/MIN

- 2.3.3 DAMPING FILTER
- 2.4 FAIL-SAFE
  - 2.4.1 MATERIAL LEVEL
  - 2.4.2 LOE TIMER
  - 2.4.3 FAIL-SAFE MA VALUE
- 2.5 CURRENT OUTPUT
  - 2.5.1 CURR. OUT. FUNC. (LUT420)
  - 2.5.2 CURR. OUT. FUNC. (LUT430, 440)
  - 2.5.3 4 MA SETPOINT
  - 2.5.4 20 MA SETPOINT
  - 2.5.5 MIN. MA LIMIT
  - 2.5.6 MAX. MA LIMIT
  - 2.5.7 MANUAL VALUE
  - 2.5.8 CURRENT OUTPUT VALUE
- 2.6 VOLUME
  - 2.6.1 VESSEL SHAPE
  - 2.6.2 VOLUME UNITS
  - 2.6.3 MAX. VOLUME
  - 2.6.4 DIMENS. A
  - 2.6.5 DIMENS. L
  - 2.6.6 USER DEFINED UNIT
  - 2.6.7 TABLE 1-8
  - 2.6.8 TABLE 9-16
  - 2.6.9 TABLE 17-24
  - 2.6.10 TABLE 25-32
- 2.7 PUMPS
  - 2.7.1 BASIC SETUP
    - 2.7.1.1 PUMP CONTROL ENABLE
    - 2.7.1.2 RELAY PUMP 1
    - 2.7.1.3 RELAY PUMP 2
    - 2.7.1.4 PUMP CONTROL MODE (LUT420)
    - 2.7.1.5 PUMP CONTROL MODE (LUT430, 440)
    - 2.7.1.6 ON SETPOINT PUMP 1
    - 2.7.1.7 OFF SETPOINT PUMP 1
    - 2.7.1.8 ON SETPOINT PUMP 2
    - 2.7.1.9 OFF SETPOINT PUMP 2
    - 2.7.1.10 SERVICE RATIO PUMP 1
    - 2.7.1.11 SERVICE RATIO PUMP 2
  - 2.7.2 MODIFIERS
    - 2.7.2.1 WALL CLING REDUCTION
      - 2.7.2.1.1 ENABLE
      - 2.7.2.1.2 LEVEL SETPOINT VARIATION
    - 2.7.2.2 ENERGY SAVINGS (LUT430, 440 only)
      - 2.7.2.2.1 ENABLE
      - 2.7.2.2.2 PEAK LEAD TIME

- 2.7.2.2.3 PEAK 1 START TIME
- 2.7.2.2.4 PEAK 1 END TIME
- 2.7.2.2.5 PEAK 2 START TIME
- 2.7.2.2.6 PEAK 2 END TIME
- 2.7.2.2.7 PEAK 3 START TIME
- 2.7.2.2.8 PEAK 3 END TIME
- 2.7.2.2.9 PEAK 4 START TIME
- 2.7.2.2.10 PEAK 4 END TIME
- 2.7.2.2.11 PEAK 5 START TIME
- 2.7.2.2.12 PEAK 5 END TIME
- 2.7.2.2.13 PEAK ON SETPOINT PUMP 1
- 2.7.2.2.14 PEAK OFF SETPOINT PUMP 1
- 2.7.2.2.15 PEAK ON SETPOINT PUMP 2
- 2.7.2.2.16 PEAK OFF SETPOINT PUMP 2
- 2.7.2.3 PUMP RUN-ON (LUT430, 440 only)
  - 2.7.2.3.1 ENABLE
  - 2.7.2.3.2 RUN-ON INTERVAL
  - 2.7.2.3.3 RUN-ON DURATION PUMP 1
  - 2.7.2.3.4 RUN-ON DURATION PUMP 2
- 2.7.2.4 PUMP START DELAYS (LUT430, 440 only)
  - 2.7.2.4.1 DELAY BETWEEN STARTS
  - 2.7.2.4.2 POWER RESUMPTION DELAY
- 2.7.3 TOTALIZERS (LUT430, 440 only)
  - 2.7.3.1 RUNNING TOTALIZER
  - 2.7.3.2 TOTALIZER DECIMAL POSITION
  - 2.7.3.3 TOTALIZER MULTIPLIER
  - 2.7.3.4 INFLOW/DISCHARGE ADJUST
  - 2.7.3.5 RESET RUNNING TOTALIZER
- 2.8 ALARMS
  - 2.8.1 HIGH LEVEL ALARM
    - 2.8.1.1 ENABLE
    - 2.8.1.2 HIGH LEVEL VALUE ON
    - 2.8.1.3 HIGH LEVEL VALUE OFF
    - 2.8.1.4 ASSIGNED RELAY
    - 2.8.1.5 ALARM STATE
  - 2.8.2 LOW LEVEL ALARM
    - 2.8.2.1 ENABLE
    - 2.8.2.2 LOW LEVEL VALUE ON
    - 2.8.2.3 OW LEVEL VALUE OFF
    - 2.8.2.4 ASSIGNED RELAY
    - 2.8.2.5 ALARM STATE
  - 2.8.3 SWITCH (DI) ALARM
    - 2.8.3.1 ENABLE
    - 2.8.3.2 DISCRETE INPUT NUMBER
    - 2.8.3.3 DISCRETE INPUT STATE

- 2.8.3.4 ASSIGNED RELAY
- 2.8.3.5 ALARM STATE
- 2.8.4 IN-BOUNDS LEVEL ALARM
  - 2.8.4.1 ENABLE
  - 2.8.4.2 HIGH LEVEL VALUE
  - 2.8.4.3 LOW LEVEL VALUE
  - 2.8.4.4 ASSIGNED RELAY
  - 2.8.4.5 ALARM STATE
- 2.8.5 OUT-OF-BOUNDS LEVEL ALARM
  - 2.8.5.1 ENABLE
  - 2.8.5.2 HIGH LEVEL VALUE
  - 2.8.5.3 LOW LEVEL VALUE
  - 2.8.5.4 ASSIGNED RELAY
  - 2.8.5.5 ALARM STATE
- 2.8.6 LOW TEMPERATURE ALARM
  - 2.8.6.1 ENABLE
  - 2.8.6.2 LOW TEMPERATURE VALUE ON
  - 2.8.6.3 LOW TEMPERATURE VALUE OFF
  - 2.8.6.4 ASSIGNED RELAY
  - 2.8.6.5 ALARM STATE
- 2.8.7 HIGH TEMPERATURE ALARM
  - 2.8.7.1 ENABLE
  - 2.8.7.2 HIGH TEMPERATURE VALUE ON
  - 2.8.7.3 HIGH TEMPERATURE VALUE OFF
  - 2.8.7.4 ASSIGNED RELAY
  - 2.8.7.5 ALARM STATE
- 2.8.8 FAIL-SAFE FAULT ALARM
  - 2.8.8.1 ENABLE
  - 2.8.8.2 ASSIGNED RELAY
  - 2.8.8.3 ALARM STATE
- 2.8.9 HIGH FLOWRATE ALARM (LUT440 only)
  - 2.8.9.1 ENABLE
  - 2.8.9.2 HIGH FLOWRATE VALUE ON
  - 2.8.9.3 HIGH FLOWRATE VALUE OFF
  - 2.8.9.4 ASSIGNED RELAY
  - 2.8.9.5 ALARM STATE
- 2.8.10 LOW FLOWRATE ALARM (LUT440 only)
  - 2.8.10.1 ENABLE
  - 2.8.10.2 LOW FLOWRATE VALUE ON
  - 2.8.10.3 LOW FLOWRATE VALUE OFF
  - 2.8.10.4 ASSIGNED RELAY
  - 2.8.10.5 ALARM STATE
- 2.8.11 RELAY LOGIC
  - 2.8.11.1 RELAY 1 LOGIC
  - 2.8.11.2 RELAY 2 LOGIC

- 2.8.11.3 RELAY 3 LOGIC
- 2.8.12 TIME TO SPILL
  - 2.8.12.1 LEVEL TO SPILL
  - 2.8.12.2 MINUTES LEFT TO SPILL
- 2.9 DISCRETE INPUTS
  - 2.9.1 BACKUP LEVEL OVERRIDE
    - 2.9.1.1 ENABLE
    - 2.9.1.2 LEVEL OVERRIDE VALUE
    - 2.9.1.3 DISCRETE INPUT NUMBER
  - 2.9.2 DISCRETE INPUT LOGIC
    - 2.9.2.1 DISCRETE INPUT 1 LOGIC
    - 2.9.2.2 DISCRETE INPUT 1 SCALED STATE
    - 2.9.2.3 DISCRETE INPUT 2 LOGIC
    - 2.9.2.4 DISCRETE INPUT 2 SCALED STATE
  - 2.9.3 PUMP INTERLOCK (LUT430, 440 only)
    - 2.9.3.1 ENABLE PUMP 1
    - 2.9.3.2 PUMP 1 DISCRETE INPUT
    - 2.9.3.3 ENABLE PUMP 2
    - 2.9.3.4 PUMP 2 DISCRETE INPUT
- 2.10 DATA LOGGING
  - 2.10.1 LOGGING MODE
  - 2.10.2 PROCESS VALUE LOG
    - 2.10.2.1 ENABLE
    - 2.10.2.2 PROCESS VALUES LOG RATE
  - 2.10.3 ALARM LOG
    - 2.10.3.1 ENABLE
  - 2.10.4 FLOW LOG (LUT430, 440 only)
    - 2.10.4.1 FLOW LOG MODE (LUT430)
    - 2.10.4.2 FLOW LOG MODE (LUT440)
    - 2.10.4.3 STANDARD FLOW LOG INTERVAL
    - 2.10.4.4 STANDARD FLOW LOG SETPOINT
    - 2.10.4.5 RAPID FLOW LOG INTERVAL
    - 2.10.4.6 RAPID FLOW LOG SETPOINT
  - 2.10.5 DELETE LOGS
- 2.11 OTHER CONTROL
  - 2.11.1 ELAPSED TIME RELAY
    - 2.11.1.1 ENABLE
    - 2.11.1.2 INTERVAL
    - 2.11.1.3 RELAY DURATION
    - 2.11.1.4 ASSIGNED RELAY
    - 2.11.1.5 RELAY LOGIC
  - 2.11.2 TIME OF DAY RELAY
    - 2.11.2.1 ENABLE
    - 2.11.2.2 ACTIVATION TIME
    - 2.11.2.3 RELAY DURATION

- 2.112.4 ASSIGNED RELAY
- 2.11.2.5 RELAY LOGIC
- 2.11.3 EXTERNAL TOTALIZER (LUT430, 440 only)
  - 2.11.3.1 ENABLE
  - 2.11.3.2 MULTIPLIER
  - 2.11.3.3 RELAY DURATION
  - 2.11.3.4 ASSIGNED RELAY
  - 2.11.3.5 RELAY LOGIC
- 2.11.4 EXTERNAL SAMPLER (LUT430, 440 only)
  - 2.11.4.1 ENABLE
  - 2.11.4.2 MULTIPLIER
  - 2.11.4.3 INTERVAL
  - 2.11.4.4 RELAY DURATION
  - 2.11.4.5 ASSIGNED RELAY
  - 2.11.4.6 RELAY LOGIC
- 2.12 SIGNAL PROCESSING
  - 2.12.1 TEMPERATURE AND VELOCITY
    - 2.12.1.1 SOUND VELOCITY
    - 2.12.1.2 PROCESS TEMPERATURE
    - 2.12.1.3 TEMPERATURE SOURCE
    - 2.12.1.4 FIXED TEMPERATURE
    - 2.12.1.5 SOUND VELOCITY AT 20 DEGREES C
    - 2.12.1.6 AUTO SOUND VELOCITY
  - 2.12.2 ECHO SELECT
    - 2.12.2.1 ALGORITHM
    - 2.12.2.2 ECHO THRESHOLD
    - 2.12.2.3 REFORM ECHO
    - 2.12.2.4 NARROW ECHO FILTER
    - 2.12.2.5 SUBMERGENCE DETECTION
    - 2.12.2.6 SHORT SHOT ENABLED
    - 2.12.2.7 SHORT ECHO THRESHOLD
    - 2.12.2.8 SHORT SHOT RANGE
    - 2.12.2.9 SHORT SHOT FLOOR
  - 2.12.3 TVT SETUP
    - 2.12.3.1 AUTO FALSE ECHO SUPPRESSION
    - 2.12.3.2 AUTO SUPP RANGE
    - 2.12.3.3 HOVER LEVEL
    - 2.12.3.4 SHAPER MODE
  - 2.12.4 TVT SHAPER
    - 2.12.4.1 BRKPT. 1-8
    - 2.12.4.2 BRKPT. 9-16
    - 2.12.4.3 BRKPT. 17-24
    - 2.12.4.4 BRKPT. 25-32
    - 2.12.4.5 BRKPT. 33-40
  - 2.12.5 MEAS. VALUES

- 2.12.5.1 LEVEL MEAS.
- 2.12.5.2 SPACE MEAS.
- 2.12.5.3 DISTANCE MEAS.
- 2.12.5.4 VOLUME MEAS.
- 2.12.5.5 HEAD MEAS.
- 2.12.5.6 FLOW MEAS. (LUT430, 440 only)
- 2.13 DISPLAY
  - 2.13.1 LOCAL DISPLAY BACKLIGHT
  - 2.13.2 LCD CONTRAST
- 2.14 DATE AND TIME
  - 2.14.1 DATE
  - 2.14.2 TIME
  - 2.14.3 DAYLIGHT SAVING
    - 2.14.3.1 ENABLE
    - 2.14.3.2 STARTING ORDINAL
    - 2.14.3.3 STARTING DAY
    - 2.14.3.4 STARTING MONTH
    - 2.14.3.5 ENDING ORDINAL
    - 2.14.3.6 ENDING DAY
    - 2.14.3.7 ENDING MONTH
- 2.15 FLOW (LUT430, 440 only)
  - 2.15.1 PRIMARY MEASURING DEVICE
  - 2.15.2 AUTO ZERO HEAD
  - 2.15.3 BASIC SETUP
    - 2.15.3.1 METHOD OF FLOW CALCULATION
    - 2.15.3.2 FLOW EXPONENT
    - 2.15.3.3 MAXIMUM HEAD
    - 2.15.3.4 MAXIMUM FLOW AT 20MA
    - 2.15.3.5 ZERO HEAD OFFSET
    - 2.15.3.6 FLOWRATE DECIMAL
    - 2.15.3.7 FLOWRATE UNITS
    - 2.15.3.8 USER DEFINED UNIT
    - 2.15.3.9 LOW FLOW CUTOFF
  - 2.15.4 PMD DIMENSIONS
    - 2.15.4.1 K FACTOR
    - 2.15.4.2 V NOTCH ANGLE
    - 2.15.4.3 SLOPE
    - 2.15.4.4 ROUGHNESS COEFFICIENT
    - 2.15.4.5 OCM DIMENSION 1
    - 2.15.4.6 OCM DIMENSION 2
    - 2.15.4.7 OCM DIMENSION 3
    - 2.15.4.8 OCM DIMENSION 4
  - 2.15.5 UNIVERSAL HEAD VS FLOW
    - 2.15.5.1 TABLE 1-8
    - 2.15.5.2 TABLE 9-16



- 2.15.5.3 TABLE 17-24
- 2.15.5.4 TABLE 25-32
- 2.16 TOTALIZERS (LUT430, 440 only)
  - 2.16.1 DAILY TOTALIZER
  - 2.16.2 RUNNING TOTALIZER
  - 2.16.3 TOTALIZER DECIMAL POSITION
  - 2.16.4 TOTALIZER MULTIPLIER
  - 2.16.5 RESET DAILY TOTALIZER
  - 2.16.6 RESET RUNNING TOTALIZER
- 3. MAINTENANCE AND DIAGNOSTICS
  - 3.1 IDENTIFICATION
    - 3.1.1 TAG
    - 3.1.2 LONG TAG
    - 3.1.3 DESCRIPTOR
    - 3.1.4 MESSAGE
    - 3.1.5 INSTALLATION DATE
    - 3.1.6 PRODUCT
    - 3.1.7 ORDER NO.
    - 3.1.8 SERIAL NUMBER
    - 3.1.9 FINAL ASSEMBLY NUMBER
    - 3.1.10 HARDWARE REV
    - 3.1.11 FIRMWARE REV
    - 3.1.12 LOADER REV
    - 3.1.13 MANUF. DATE
    - 3.1.14 ORDER OPTION
  - 3.2 DIAGNOSTICS
    - 3.2.1 ECHO PROFILE
    - 3.2.2 TREND
    - 3.2.3 MASTER RESET
    - 3.2.4 POWER-ON RESETS
    - 3.2.5 POWER-ON TIME
    - 3.2.6 VIEW LOGS
      - 3.2.6.1 ALARMS
      - 3.2.6.2 OCM
      - 3.2.6.3 DAILY TOTALS
      - 3.2.6.4 PV
    - 3.2.7 PUMP RECORDS
      - 3.2.7.1 RUN TIME RELAY 2
      - 3.2.7.2 RUN TIME RELAY 3
      - 3.2.7.3 RELAY PUMP 1
      - 3.2.7.4 RELAY PUMP 2
    - 3.2.8 TEMPERATURE PEAK VALUES
      - 3.2.8.1 HIGHEST VALUE
      - 3.2.8.2 LOWEST VALUE
    - 3.2.9 ECHO QUALITY

- 3.2.9.1 FIGURE OF MERIT
- 3.2.9.2 CONFIDENCE
- 3.2.9.3 ECHO STRENGTH
- 3.2.9.4 NOISE AVERAGE
- 3.2.9.5 NOISE PEAK
- 3.3 MAINTENANCE
  - 3.3.1 TRANSDUCER ENABLE
  - 3.3.2 BACKUP CONTROL
  - 3.3.3 REMAIN. DEV. LIFE
    - 3.3.3.1 LIFETIME EXPECTED
    - 3.3.3.2 TIME IN OPER.
    - 3.3.3.3 REMAIN. LIFETIME
    - 3.3.3.4 REMINDER ACTIV.
    - 3.3.3.5 REMIND. 1 (REQ.)
    - 3.3.3.6 REMIND. 2 (DEM.)
    - 3.3.3.7 MAINT STAT
    - 3.3.3.8 ACK STATUS
    - 3.3.3.9 ACK
  - 3.3.4 REMAIN SENS LIFE
    - 3.3.4.1 LIFETIME EXPECTED
    - 3.3.4.2 TIME IN OPER.
    - 3.3.4.3 REMAIN. LIFETIME
    - 3.3.4.4 REMINDER ACTIV.
    - 3.3.4.5 REMIND. 1 (REQ.)
    - 3.3.4.6 REMIND. 2 (DEM.)
    - 3.3.4.7 MAINT STAT
    - 3.3.4.8 ACK STATUS
    - 3.3.4.9 ACK
  - 3.3.5 SERVICE SCHED.
    - 3.3.5.1 SERV. INTERVAL
    - 3.3.5.2 TIME LAST SERV
    - 3.3.5.3 TIME NEXT SERVICE
    - 3.3.5.4 REMINDER ACTIV.
    - 3.3.5.5 REMIND. 1 (REQ.)
    - 3.3.5.6 REMIND. 2 (DEM.)
    - 3.3.5.7 MAINT STAT
    - 3.3.5.8 ACK STATUS
    - 3.3.5.9 ACK
  - 3.3.6 CALIB. SCHED.
    - 3.3.6.1 CALIB. INTERVAL
    - 3.3.6.2 TIME LAST CALIB
    - 3.3.6.3 TIME NEXT CALIB
    - 3.3.6.4 REMINDER ACTIV.
    - 3.3.6.5 REMIND. 1 (REQ.)
    - 3.3.6.6 REMIND. 2 (DEM.)

- 3.3.6.7 MAINT STAT
- 3.3.6.8 ACK STATUS
- 3.3.6.9 ACK
- 3.4 SIMULATION
  - 3.4.1 LEVEL
    - 3.4.1.1 LEVEL SIMULATION ENABLE
    - 3.4.1.2 LEVEL VALUE
    - 3.4.1.3 RAMP
    - 3.4.1.4 RAMP RATE
  - 3.4.2 DISCRETE INPUTS
    - 3.4.2.1 DISCRETE INPUT 1
    - 3.4.2.2 DISCRETE INPUT 2
  - 3.4.3 PUMP ACTIVATIONS
- 4. COMMUNICATION
  - 4.1 DEVICE ADDRESS
- 5. SECURITY
  - 5.1 WRITE PROTECTION
  - 5.2 USER PIN
- 6. LANGUAGE

# Glossary

## **accuracy**

degree of conformity of a measure to a standard or a true value.

## **algorithm**

a prescribed set of well-defined rules or processes for the solution of a problem in a finite number of steps.

## **ambient temperature**

the temperature of the surrounding air that comes in contact with the enclosure of the device.

## **Auto False-Echo Suppression**

a technique used to adjust the level of a TVT curve to avoid the reading of false echoes.

## **Auto False-Echo Suppression Range**

defines the endpoint of the TVT distance. This is used in conjunction with auto false echo suppression.

## **blanking**

a blind zone extending away from the reference point plus any additional shield length. The device is programmed to ignore this zone.

## **confidence**

describes the quality of an echo. Higher values represent higher quality. Confidence threshold defines the minimum value.

## **damping**

term applied to the performance of a device to denote the manner in which the measurement settles to its steady indication after a change in the value of the level.

## **dB (decibel)**

a unit used to measure the amplitude of signals.

**derating**

to decrease a rating suitable for normal conditions according to guidelines specified for different conditions.

**echo**

a signal that has been reflected with sufficient magnitude and delay to be perceived in some manner as a signal distinct from that directly transmitted. Echoes are frequently measured in decibels relative to the directly transmitted signal.

**echo confidence**

the recognition of the validity of the echo. A measure of echo reliability.

**echo lock window**

a window centered on an echo in order to locate and display the echo's position and true reading. Echoes outside the window are not immediately processed.

**Echo marker**

a marker that points to the processed echo.

**Echo processing**

the process by which the device determines echoes.

**Echo profile**

a graphical display of a processed echo.

**Echo strength**

describes the strength of the selected echo in dB referred to 1  $\mu\text{V}_{\text{rms}}$ .

**false echo**

any echo which is not the echo from the desired target. Generally, false echoes are created by vessel obstructions.

**far range**

the distance below the zero percent or empty point in a vessel.

**figure of merit**

combines noise level, tracking quality, and signal strength to measure the quality of the reported echo value.

**frequency**

the number of periods occurring per unit time. Frequency may be stated in cycles per second.

**HART**

Highway Addressable Remote Transducer. An open communication protocol used to address field devices.

**Hertz (Hz)**

unit of frequency, one cycle per second. 1 Gigahertz (GHz) is equal to  $10^9$  Hz.

**multiple echoes**

secondary echoes that appear as double, triple, or quadruple echoes in the distance from the target echo.

**parameters**

in programming, variables that are given constant values for specific purposes or processes.

**range**

distance between a transducer and a target.

**shot**

one transmit pulse or measurement.

**speed of sound**

the speed at which sound is propagated through some medium under specified conditions.

**stilling well**

see stillpipe.

**stillpipe**

a pipe that is mounted inside a vessel parallel to the vessel wall, and is open to the vessel at the bottom.

**TVT (time varying threshold)**

a time-varying curve that determines the threshold level above which echoes are determined to be valid.

# Index

## A

abbreviations and identifications list, **Error! Bookmark not defined.**  
adjusting, 286  
alarm  
    temperature, 101  
alarms, 99  
    common parameters, 99  
algorithm, 296  
alternate duty assist, 105, 112, 189

## B

backup, 267  
backup level override, 91

## C

cable  
    coaxial cable, 38  
    routing, 22  
Catalog  
    catalog sheets, 309  
Certificates, 309  
characterization chart, 97  
Connect, 267  
Customer Support, (Refer to Technical support)

## D

damping, 300  
data logging, 154  
date, 232  
dimensions, 84  
discrete input, 155, 158  
discrete inputs  
    pump interlock, 113  
    wiring, 92  
Disposal, 269  
distance calculation, 302  
Downloads, 309

## E

echo select  
    algorithm, 224  
edit mode  
    handheld programmer, key functions, 58  
exponential flow, 126  
external totalizers, 120

## F

fail safe, 84, 302  
far range, 299  
Figure of Merit (FOM), 249, 295, 297  
fixed duty assist, 107  
fixed duty backup, 107  
flow calculation, 306  
flume  
    cut throat, 130  
    H-flume, 148  
    Khafagi Venturi, 131  
    Leopold Lagco, 129  
    Palmer Bowlus, 147  
    parshall, 128  
    rectangular, 133  
FOM, 249, 295, 297  
function keys  
    measurement mode, 54  
    navigation mode, 55

## H

handheld programmer  
    edit mode, 58  
    measurement mode, 54  
    navigation, 55  
HART, 157  
    multi-drop mode, 161  
hazardous area installations  
    wiring requirements, 49  
Hotline, (Refer to Support request)



**I**

identifications and abbreviations list, **Error! Bookmark not defined.**  
 in bounds, 100  
 interlock  
   pump, 113

**K**

key functions  
   edit mode, 58

**L**

LCD display  
   measurement mode, 52, 59  
   program mode, 53  
 level, 100, 155  
 level alarms, 100  
 Lithium batteries  
   Return, 269  
 LOE  
   fail safe mode, 302  
   loss of echo (LOE), 84  
   LUI, commissioning, 50  
 LUI, 19  
   parameter reference, 171  
   Quick Start Wizards, 58

**M**

Manuals, 309  
 measurement  
   difficulties, 282  
   set up, setting up, single point, starting, 83  
 mounting  
   wall mounting, 24

**N**

near range, 299  
 noise problems, 280  
 noise sources, 281

**O**

OCM (open channel monitoring), 123  
   common parameters, 124  
   cut throat, 130

flow characterization chart, 150  
 H-flume, 148  
 Khafagi Venturi flume, 131  
 Leopold Lagco flume, 129  
 Palmer Bowlus flume, 147  
 parshall flume, 128  
 rectangular flume, 133  
 universal calculation, 149  
 V-Notch weir, 143  
 weirs, 126  
 zero head, 125  
 out of bounds, 100

**P**

parameter  
   handheld, 54  
   power, 35  
   relays, 89  
 parshall, 152  
 process, 157  
 programming  
   alarms, 99  
   relays, 84  
 pump  
   alternate duty backup, 106  
   alternate duty backup, alternate duty assist, 104  
   fixed duty assist, fixed duty backup, 104  
   off setpoint, 106, 107, 107, 108, 109, 110, 112  
   on setpoint, 112  
   on setpoint, off setpoint, 104  
   on setpoints, 105, 106, 107, 108, 108, 109  
   run on, 115  
   start delay, 115  
   totalizing volume, 114  
 pump control  
   algorithms, 103, 103  
 pump interlock, 113  
 pump strategies, 103

**Q**

quick start, 83

**R**

randomize setpoints, 115  
 rate, 102  
 record temperature, 249  
 relay, 120  
   modifiers, parameters, 89

relays, 84  
response rate, 83, 300  
Return procedure, 269  
run on, 115

## S

samplers, 120  
scum ring, 115  
Service, 310  
Service and support  
    Internet, 310  
service ratio duty assist, 108  
service ratio duty backup, 109  
settings  
    adjust parameters via LUI, 56  
    synchronization, 44  
simulation, 155  
single point, 83  
sound velocity, 303  
start delay, 115  
Support, 310  
Support request, 310

## T

tank shape, 95  
technical support  
    contact information, 79  
Technical support, 310  
    partner, 310  
    personal contact, 310  
temperature  
    alarms, 101  
testing  
    connection, 39  
    enable/disable, 59  
    transducers, 38  
time control, 118  
time to spill, 211  
totalizer, 121  
transducers  
    enable/disable, 250  
transmit pulse, 294  
trapezoidal, 151  
trends, 153  
troubleshooting  
    noise problems, 280  
    TS-3, 39

## U

universal  
    example, 97  
    volume, 95

## V

vessel shape  
    selection, 184  
viewing via LUI, 153

