



## O & M Manual



## MetriNet Controller With Cellular Modem

### Home Office

Analytical Technology, Inc.  
6 Iron Bridge Drive  
Collegeville, PA 19426  
Phone: 800-959-0299  
610-917-0991  
Fax: 610-917-0992  
Email: [sales@analyticaltechnology.com](mailto:sales@analyticaltechnology.com)  
Web: [www.Analyticaltechnology.com](http://www.Analyticaltechnology.com)

### European Office

ATI (UK) Limited  
Unit 1 & 2 Gatehead Business Park  
Delph New Road, Delph  
Saddleworth OL3 5DE  
Phone: +44 (0)1457-873-318  
Fax: + 44 (0)1457-874-468  
Email: [sales@atiuk.com](mailto:sales@atiuk.com)

# Table of Contents

---

<b>PART 1 - INTRODUCTION .....4</b>	
1.1 GENERAL .....4	4.1 GENERAL ..... 23
1.2 SYSTEM COMPONENTS .....5	4.2 CONTROLLER INTERFACE ..... 23
<b>PART 2 - SPECIFICATIONS .....7</b>	4.3 M-NODE ASSIGNMENT ..... 24
2.1 METRINET CONTROLLER (Q52) .....7	4.4 CONTROLLER PROGRAMMING ..... 24
2.1 METRINET PERFORMANCE SPECIFICATIONS (Q52) .8	4.41 <i>MEASURE Menu</i> .....26
2.2 METRINET FLOW CHAMBERS .....8	4.42 <i>INFO Menu</i> .....27
2.3 METRINET BUS BAR .....8	4.43 <i>SENSOR Menu</i> .....27
<b>PART 3 - INSTALLATION .....9</b>	4.44 <i>CONFIG Menu</i> .....28
3.1 SYSTEM MOUNTING .....9	4.45 <i>OPTIONS Menu</i> .....29
3.2 CONTROLLER MOUNTING .....11	4.5 SET PASSWORDS ..... 31
3.3 WALL OR PIPE MOUNT .....12	4.6 SENSOR DISPLAY ..... 31
3.4 FLOW SYSTEM MOUNTING .....13	<b>PART 5 – DATA, ALARM &amp; EVENT LOG ..... 32</b>
3.5 BUS BAR MOUNTING .....14	5.1 GENERAL ..... 32
3.6 SAMPLE CONNECTION .....14	5.2 DATA FILE FORMAT ..... 32
3.7 INTERMITTENT SAMPLING, CYCLE MODE .....16	5.3 ALARM FILE FORMAT ..... 33
3.8 ELECTRICAL CONNECTIONS .....17	5.4 EVENT FILE FORMAT ..... 34
3.81 <i>Digital Input</i> .....18	5.5 SD RAM CARD ..... 34
3.82 <i>Digital Output</i> .....18	5.6 LOCAL DATA STORAGE CAPACITY ..... 35
3.83 <i>General Power Overview</i> .....18	5.7 TRANSMITTED DATA ..... 35
3.84 <i>Power in 115VAC Unit</i> .....19	<b>PART 6 – CELLULAR SETUP ..... 37</b>
3.85 <i>Power in 12-24VDC Unit</i> .....19	6.1 SIM CARD INSTALLATION ..... 37
3.86 <i>Power in 12VDC Battery Unit</i> .....19	6.2 CONTROLLER PROGRAMMING ..... 38
3.87 <i>Battery Pack Sizing</i> .....20	<b>PART 7 – CELLULAR CONFIGURATION UTILITY ..... 40</b>
3.88 <i>Installation Site Factors</i> .....21	7.1 GENERAL ..... 40
3.9 M-NODE PREPARATION .....22	7.2 MODEM PROGRAMMING ..... 40
3.10 NODE INSTALLATION .....22	<b>PART 8 – METRINET TROUBLESHOOTING ..... 44</b>
<b>PART 4 – OPERATION .....23</b>	<b>SPARE PARTS ..... 48</b>

## TABLE OF FIGURES

---

FIGURE 1 – METRINET SYSTEM WITH 3 M-NODES .....	5
FIGURE 2 – 1 TO 4 NODE SYSTEM PANEL .....	9
FIGURE 3 – 5 - 8 NODE SYSTEM PANEL .....	10
FIGURE 4 - ENCLOSURE DIMENSIONS .....	11
FIGURE 5 - WALL MOUNT .....	12
FIGURE 6 – PIPE MOUNT .....	12
FIGURE 7 – DISCONNECTED FLOW CHAMBERS .....	13
FIGURE 8 – FLOW CHAMBER DIMENSIONS .....	14
FIGURE 9 - SENSOR BUS BAR INTERFACE .....	14
FIGURE 10 – TYPICAL INSTALLATION SAMPLE CONNECTION .....	15
FIGURE 11 – CYCLE MODE SCHEMATIC .....	16
FIGURE 12 – EXTERNAL CONNECTIONS .....	17
FIGURE 13 – GENERAL METRINET POWER .....	18
FIGURE 14 – AVERAGE VS PULSE POWER, AND STATE DIAGRAM .....	20
FIGURE 15 – METRINET CONTROLLER INTERFACE .....	23
FIGURE 16 – CONTROLLER SOFTWARE MAP .....	25
FIGURE 17 – STORED RAW MEASURED DATA FORMAT .....	33
FIGURE 18 – STORED RAW ALARM DATA FORMAT .....	34
FIGURE 19 – STORED EVENT DATA FORMAT .....	34
FIGURE 20 – MICRO-SD CARD WITH ADAPTER .....	35
FIGURE 21 – METRINET REAR PANEL SIM ACCESS .....	37
FIGURE 22 – METRINET CELLULAR MODEM BOARD WITH SIM CARD .....	38
FIGURE 23 – METRINET PC CABLE CONNECTION .....	41
FIGURE 24 – PC UTILITY CONNECTION SCREEN .....	41
FIGURE 25 – PC UTILITY CONFIG APN SCREEN .....	42
FIGURE 26 – WQHUB SETUP. MANAGE INSTRUMENTS SECTION .....	42
FIGURE 27 – WQHUB SETUP. INSTRUMENT SETTINGS .....	43
FIGURE 28 – TROUBLESHOOTING - THE METRINET COMM DEBUG FEATURE. ....	44
FIGURE 29 – TROUBLESHOOTING – RADIO MODEM RESET .....	44
FIGURE 30 – TROUBLESHOOTING – RADIO MODEM RESET .....	45
FIGURE 31 – TROUBLESHOOTING – MODEM REGISTRATION ISSUE, CREG .....	45
FIGURE 32 – TROUBLESHOOTING – CANNOT LOG INTO CLOUD SERVER .....	46
FIGURE 33 – TROUBLESHOOTING – POSSIBLE PASSWORD ISSUE ON CLOUD SERVER .....	46
FIGURE 34 – TROUBLESHOOTING – CSQ DATA .....	47

# Part 1 - Introduction

---

## 1.1 General

The MetriNet is an integrated water quality system designed for potable water distribution monitoring. The primary function is to log water quality measurements. Data may be manually collected using an SD card built into each controller. Interface options are also available to retrieve data from the unit via Modbus RTU/RS-485, Modbus TCP or Ethernet IP. With the Cell Modem option, periodic transmission of data to a user specified data storage location (cloud site) provides remote data collection.

MetriNet is a modular system consisting of a controller (Q52) and at least one sensing node (M-Node or Q32). Controllers may be connected to up to 8 M-Nodes using bus bars to consolidate communication signals. Currently available M-Nodes are as follows:

<u>Parameter</u>	<u>Range</u>	<u>Resolution</u>
Free Chlorine	0-5.00 ppm	0.01 ppm
Combined Chlorine	0-5.00 ppm	0.01 ppm
Total Chlorine	0-5.00 ppm	0.01 ppm
Turbidity	0-40.00 NTU	0.01 NTU
pH	0-14.00 pH	0.01 pH
Conductivity	0-2000 $\mu$ S	1 $\mu$ S
ORP	0-1000 mV	1 mV
Dissolved Oxygen	0-20.00 ppm	0.01 ppm
Fluoride	0.1-10.00 ppm	0.01 ppm
Dissolved Ozone	0-5.00 ppm	0.01 ppm
Chlorine Dioxide	0-5.00 ppm	0.01 ppm
Peracetic Acid	0-200 ppm	1 ppm
Hydrogen Peroxide	0-20.00 ppm	0.01 ppm
Pressure	0-300 PSI	1 PSIG

MetriNet systems are powered by either battery packs or local 12-24 VDC power supplies. The power source must be specified when ordering. A controller designed for battery operation should not be used on an external DC power supply. Units supplied for 12-24 VDC operation may be run from a battery pack but will draw more current than a unit designed strictly for battery power.

The MetriNet controller communicates with sensor nodes using the Modbus RTU protocol. Each measuring node is a complete sensor and Modbus transmitter with submersible multi-pin connector on the back. If only one sensor is used, that sensor is connected directly to the controller.

If more than one sensor is used, sensors plug into a multi-sensor bus bar, which is then connected to the controller. Systems with more than 5 sensors require 2 bus bars. Bus bar connectors are protected by push-on vinyl protective caps. Leave caps in place for any connectors not in use.

M-Nodes are installed in modular flow chambers, secured with twist-lock pins on the front of the node. Each node requires one chamber and chambers clamp together with locking rings on each end. Push-to-connect fittings are installed on each end but end fittings contain 1/8" NPT female threads to accommodate other fittings. The outlet side of the flow assembly will normally contain a fixed-flow regulator to maintain a constant flow of 200 ml/min. when sample line pressure is 1-100 PSI (.07-6.6 bar). Maximum pressure on flow chambers should not exceed 100 PSI. Recommended inlet pressure is 15-60 PSI (1-4 bar).

In operation, MetriNet controllers log measurement data at an interval programmed by the user, from a minimum of every 0.1 minute to a maximum of 99.9 minutes. Data is stored in on-board non-volatile memory which may be written to an internal SD card. If the controller contains the optional modem, data is transmitted to a cloud-based data site.



*Figure 1 – MetriNet System with 3 M-Nodes*

## 1.2 System Components

MetriNet systems are supplied in one of two ways, either as an assembled panel similar to that shown in Figure 1 or in individual components that can be mounted in an arrangement that better suits a specific application. Sensor nodes will normally not be installed in the flow chambers when packed for shipment as many sensors require preparation and/or calibration prior to use.

When unpacking the MetriNet hardware, check to verify that all items listed on the packing list have been received. Contact ATI if any discrepancies are noted. Each sensor node is marked with a part number and measurement designation on a label under the connector.



Flow Chamber Assembly



Typical M-Node



MetriNet Controller

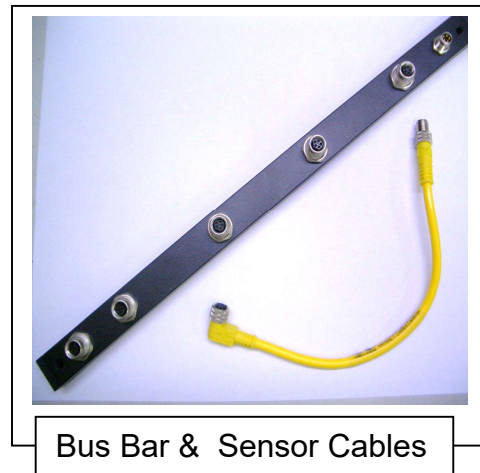

Bus Bar & Sensor Cables

# Part 2 - Specifications

---

## 2.1 MetriNet Controller (Q52)

<b>Displayed Parameters</b> (for each M-Node)	Four-digit node measurement (ppm, NTU, mV, etc.) Sensor temperature, -10.0 to 55.0 °C (14 to 131 °F) Other measurement displays on lower line dependent on specific sensor
<b>Display</b>	0.75" (19.1 mm) high 4-digit main display with sign 12-digit secondary display, 0.3" (7.6 mm) 5x7 dot matrix.
<b>Maximum Sensors</b>	8 digital Q31/Q32 sensors, of any measurement type
<b>Data Logger</b>	Internal 4MB SPI Flash memory with removable micro SD card. Although data is only held until cellular upload, internal logger can hold 230,000 data points. Running 4 sensors and collecting data every 10 minutes is 239 days of time stamped data storage.
<b>Controls</b>	4-key polycarbonate keypad, UV resistant coating
<b>Power</b>	<b>115 VAC/60Hz Version</b> , 6W max. <b>12-24 VDC Isolated Line Version</b> - @12V, 24 mA + 3 mA/Node Max. *Lower in cycle mode <b>12 VDC (8-16 VDC) Non-Isolated Battery version</b> - @12V, 6 mA + 3 mA/Node Max. *Lower in cycle mode <b>(*See section 3.83-3.88 for more detail on lowest power.)</b>
<b>Bus or Node Connection</b>	Data cable with M8 5-pin waterproof connector, 13 ft. (4 m)
<b>Ambient Temperature</b>	Controller Service, -20 to 60 °C (-4 to 140 °F) Sensor Node Service, -5 to 55°C (23 to 131 °F) Storage, -5 to 70 °C (23 to 158 °F)
<b>Ambient Humidity</b>	0 to 95%, indoor/outdoor use, non-condensing to rated ambient temperature range
<b>Electrical Certification</b>	CE/EMC to EN 61326-1:2013. Cellular modem is FCC/PTCRB and carrier certified for AT&T/Verizon. 3G GCF available.
<b>Environmental</b>	RoHS Compliant
<b>Cellular Modem</b>	GSM/GPRS, 3G, 4G/LTE, CAT-M1(LTE-M.) ATI supplied Aeris/AT&T global SIM card is standard.
<b>Enclosure</b>	NEMA 4X, polycarbonate, stainless steel hardware HWD: 4.4" (112 mm) x 4.4" (112 mm) x 3.5" (89 mm)
<b>Conduit Openings</b>	Two PG-9 cable glands, one ½" NPT 2-hole cable gland.
<b>Mounting Options</b>	Wall or pipe mount bracket standard. Bracket suitable for either 1.5" or 2" I.D. U-Bolts for pipe mounting.

**Weight** 1 lb. (0.45 kg)

**2.1 MetriNet Performance Specifications (Q52)**

**Accuracy** 1% of range  
**Repeatability** 0.5% of range  
**Sensitivity** 0.1% of range  
**Non-Linearity** 0.1% of range  
**Warm-up Time** 3 seconds to rated performance (electronics only)  
**Supply Voltage Effects** +/- 0.05% of range

**2.2 MetriNet Flow Chambers**

**Sample Pressure** 5-60 PSI recommended, 100 PSI Max.  
**Material** Glass filled Ryton® (polyphenylene sulfide)  
**O-ring** Ethylene-propylene (EP)  
**Inlet** 1/8" FNPT with 1/4" O.D. push-connect tube fitting  
**Outlet** 1/8" FNPT with 1/4" O.D. push-connect right angle tube fitting.  
**Flow Control Option** 200 ml/min. flow control element installed in outlet assembly.  
**Mounting** DIN rail adapter on bottom for 35 x 7.5 mm rail

**2.3 MetriNet Bus Bar**

**Material** Powder coated aluminum  
**Connectors** Six M8 connectors, 5 female, 1 male (connections for 5 nodes and 1 controller)  
**Size** 12" x 1/2" x 1/2" (30 x 12 x 12 mm)  
**Rating:** IP-67 when all connections made or capped



**Equipment bearing this marking may not be discarded by traditional methods in the European community after August 12 2005 per EU Directive 2002/96/EC. End users must return old equipment to the manufacturer for proper disposal.**





# Part 3 - Installation

## 3.1 System Mounting

If your MetriNet system was purchased as a complete assembly mounted on a non-metallic plate, all that's needed is to mount the plate. Systems with up to 4 Nodes are supplied on a 14" x 14" plate, 1/4" thick. Mounting holes are located in each corner as shown below. Larger systems are generally custom sizes with dimensions provided separately. For systems of 5-8 sensors, a 20" x 14" plate is available as shown in Figure 3 on the next page.

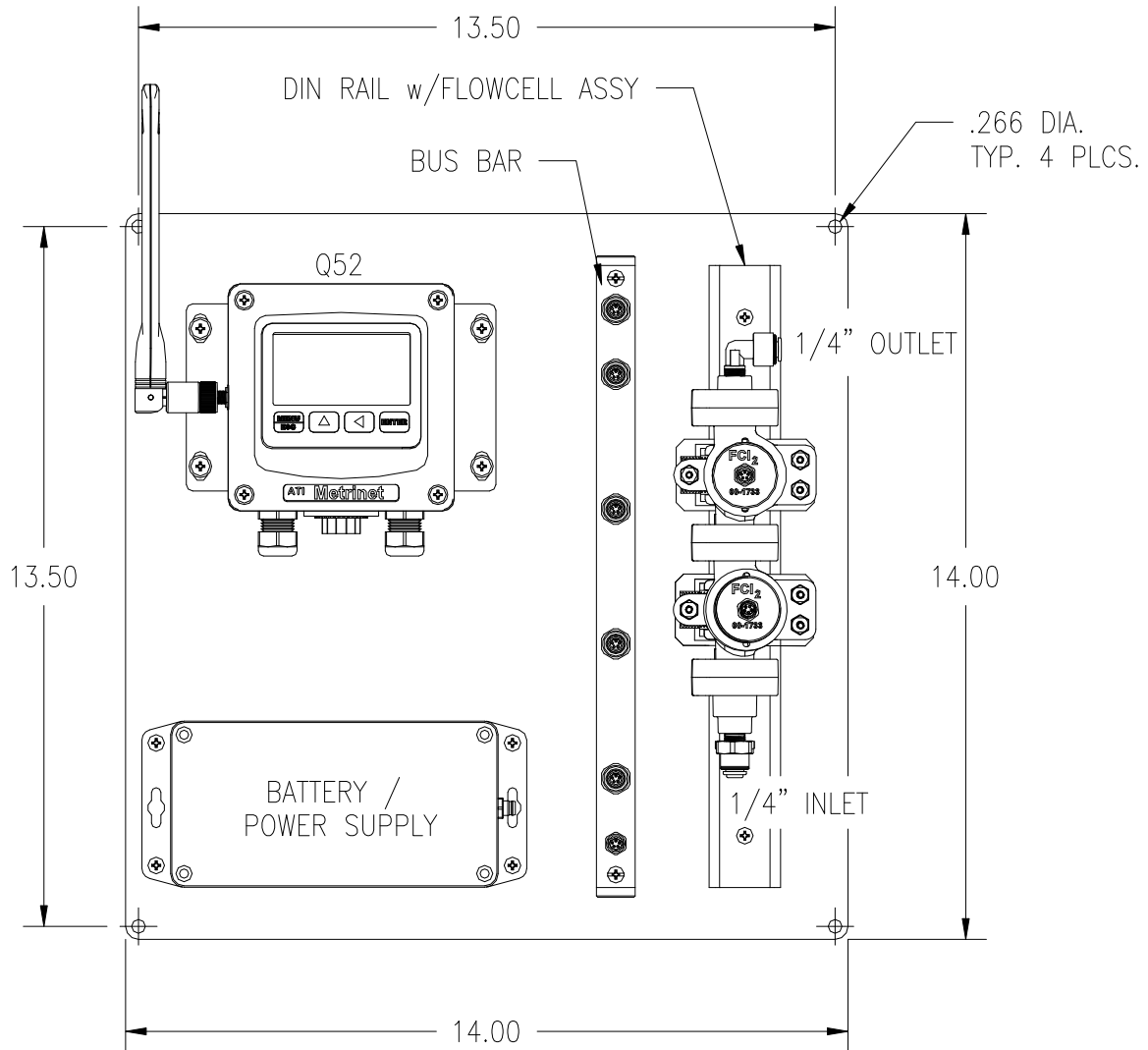

**Figure 2 – 1 to 4 Node System Panel**

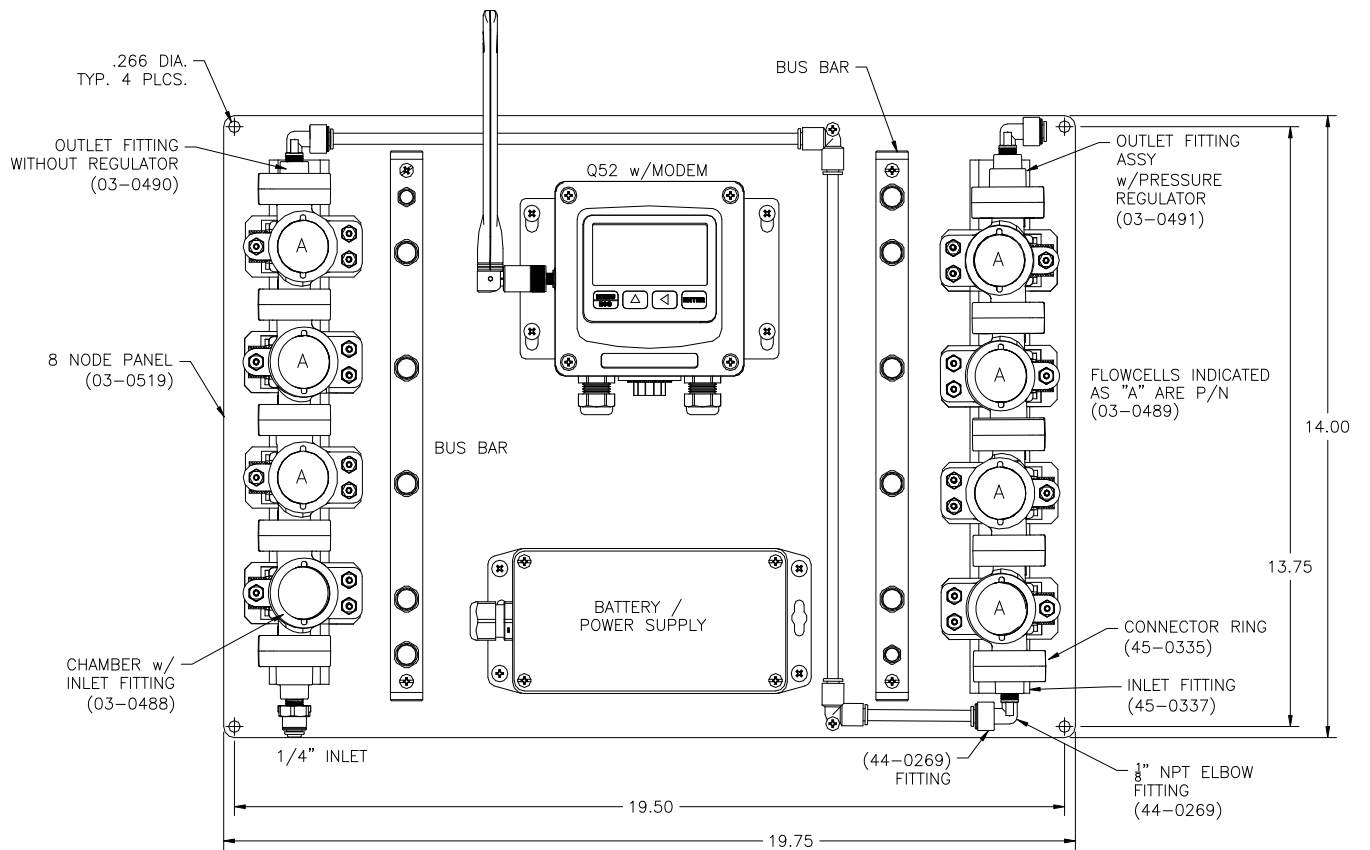

**Figure 3-5 - 8 Node System Panel**

### 3.2 Controller Mounting

MetriNet controllers are supplied with a PVC mounting plate that attaches to the back of the enclosure.

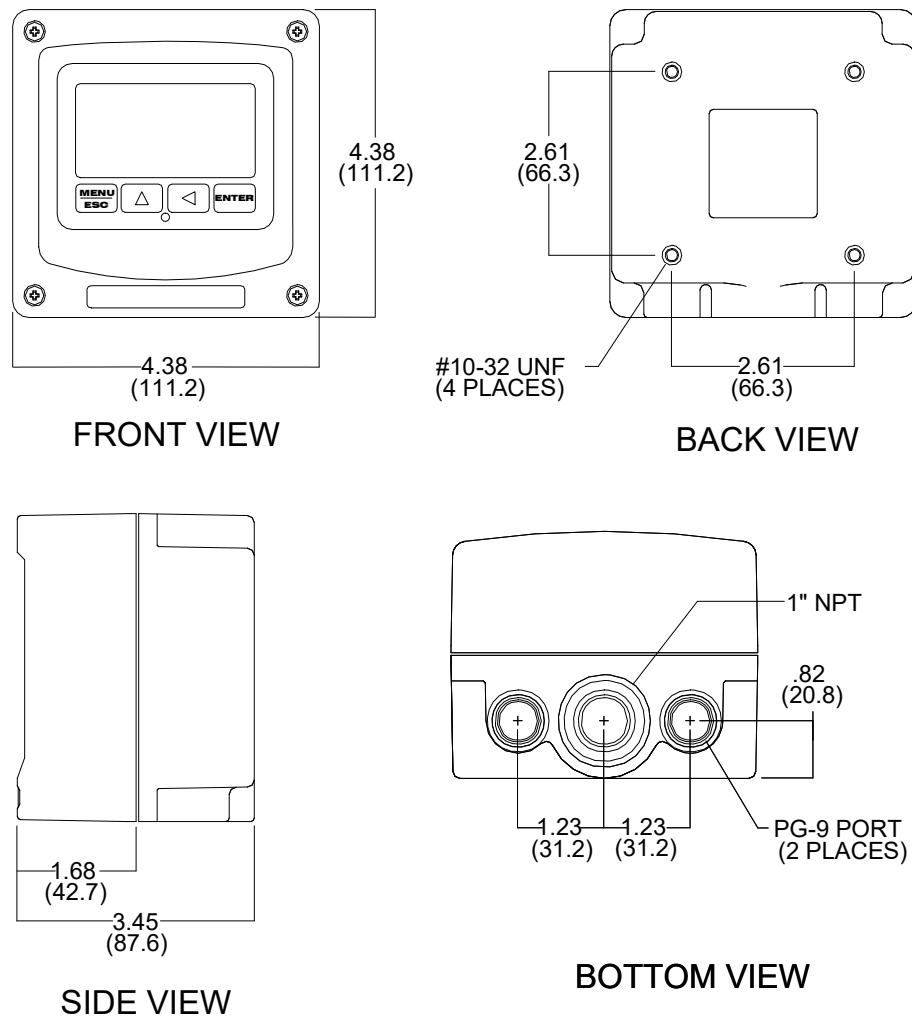

**Figure 4 - Enclosure Dimensions**

### 3.3 Wall or Pipe Mount

A PVC mounting bracket with attachment screws is supplied with each controller. The bracket is attached to the rear of the enclosure. The bracket provides for either wall or pipe mounting as shown in Figure X. Note that bracket slots are for u-bolts with 1/4-20 threads. The 1 1/2" pipe u-bolt (2" I.D. clearance) is available from ATI in type 304 stainless steel under part number 47-0005

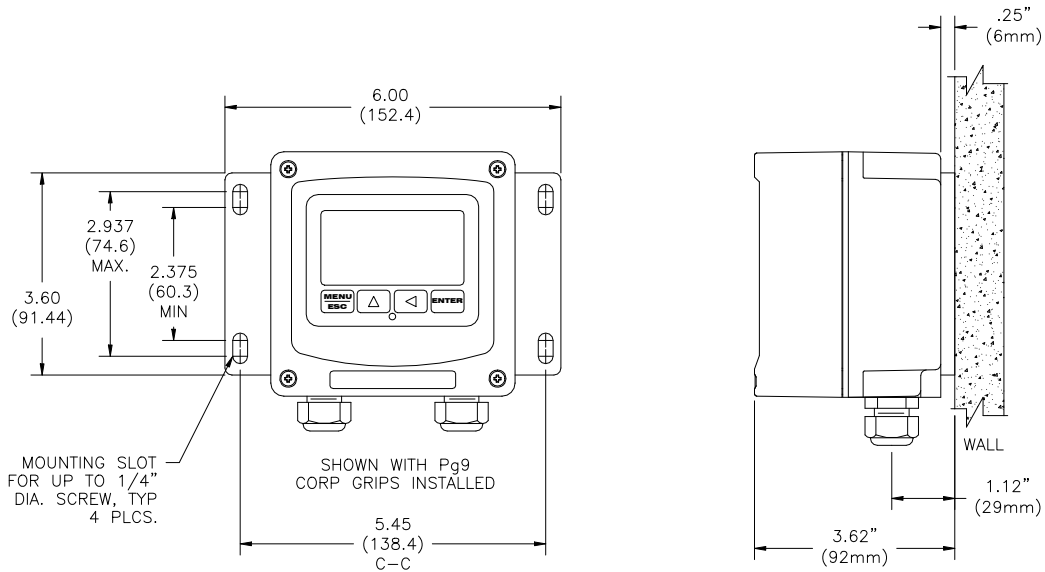

**Figure 5 - Wall Mount**

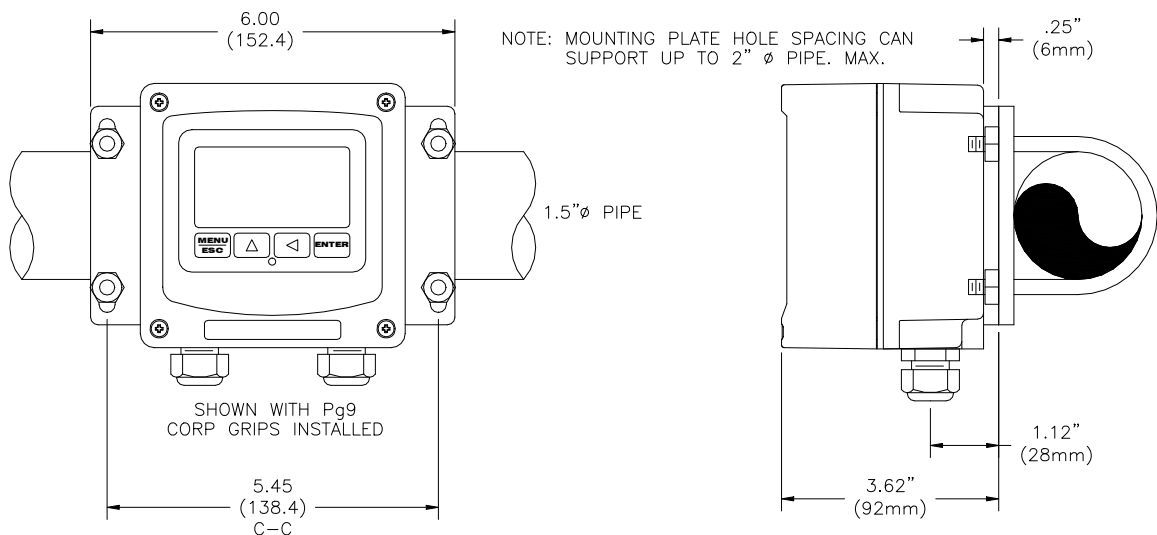

**Figure 6 – Pipe Mount**

### 3.4 Flow System Mounting

Flow chambers for MetriNet systems are modular so the size will vary depending on the number of M-Nodes to be used. Flow chambers should always be mounted vertically, with sample entering at the bottom and exiting at the top. This arrangement ensures that air does not collect near a sensor and cause inaccurate readings. Conductivity and turbidity sensors can be extremely sensitive to trapped air.

Flow chambers are supplied with DIN rail adapters for 35x7.5 mm rail. The adapters are spring loaded to allow assembled flow chambers to snap onto the rail. All chambers should be clamped together prior to putting them on the rail. Chambers clamp together using clamping rings. The picture below shows two flow chambers disconnected. Although not shown, there is an O-ring in the inlet side of the flow chamber for sealing. When disconnecting, be sure the O-ring remains in place.

The lock rings between flow chambers and inlet/outlet fittings rotate downward by about 45 degrees to open and back up to close again. Opening and closing flow assemblies is not normally required except possibly for cleaning or inspection. It takes a bit of practice to reassemble these chambers.



**Figure 7 – Disconnected Flow Chambers**

The overall size of a flow assembly will depend on how many M-Nodes are to be used. Shown below are dimensions for height and width. The overall length will vary from about 6" (152 mm) for a single assembly to about 13" (330 mm) for a 4-chamber assembly. It is best to limit assemblies to no more than 5 M-Nodes, using a second assembly and interconnecting the two assemblies if larger systems are to be used. For example, a 6 Node system would be easier to handle with two 3-chamber flow assemblies connected by tubing. If two flow assemblies are used, run tubing from the outlet of the first back down to the bottom of the second so the flow is in the UP direction through both assemblies.

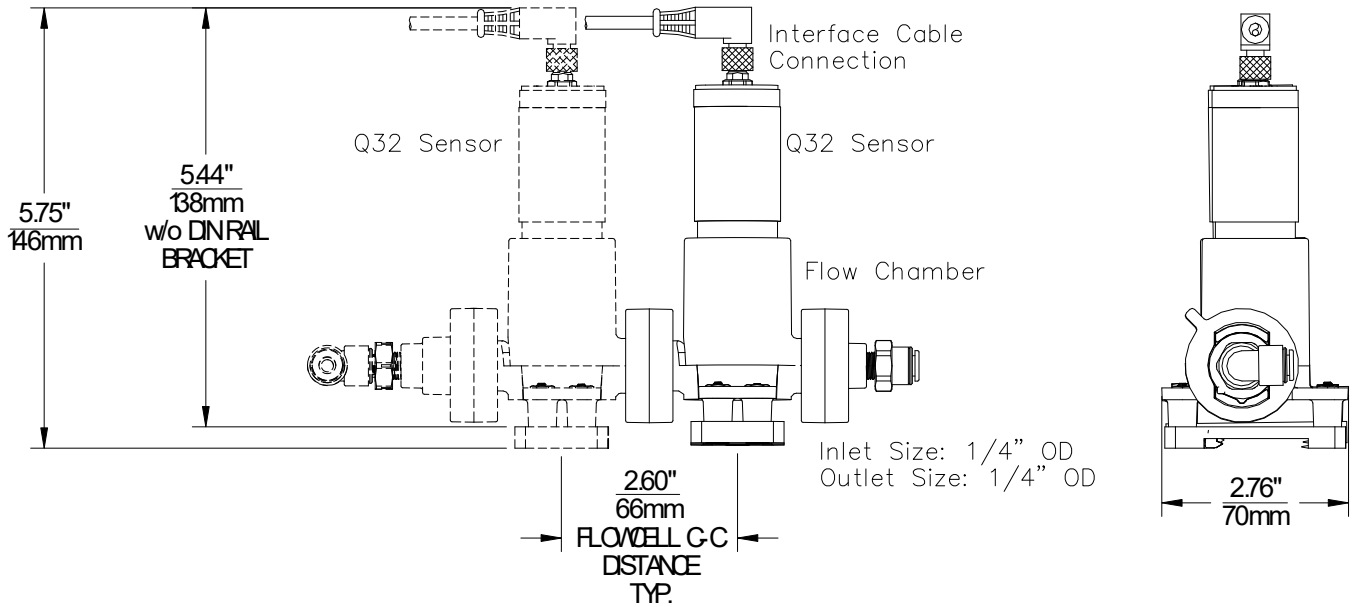
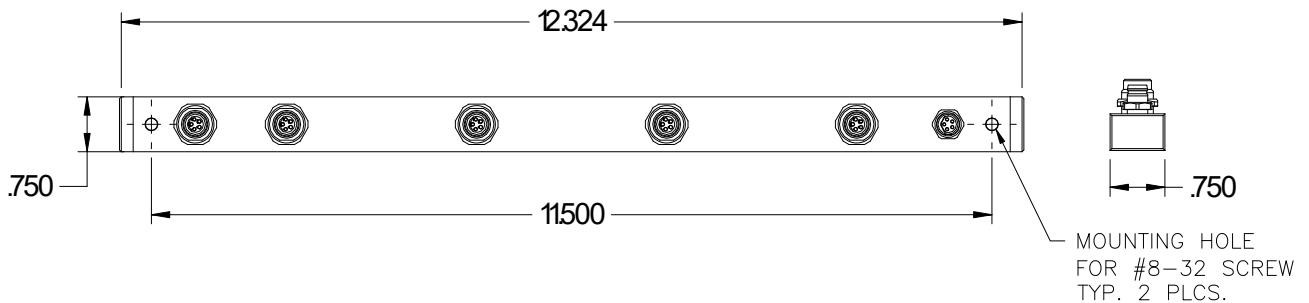

**Figure 8 – Flow Chamber Dimensions**

### 3.5 Bus Bar Mounting

MetriNet controllers connected to only one sensing node will not use a bus bar. All systems with more than one sensor will need at least one. The bus bar is an assembled communication network allowing the controller to speak to any node connected to the bus bar.

There are connectors for up to 5 nodes on each bar. If more than 5 nodes are to be used, 2 bars will be needed plus a jumper cable to connect the 2 bars together. The use of 2 bus bars allows a maximum of 8 nodes to be connected to a single controller. Bus bar dimensions are shown below. Bus bars should always be mounted close to and parallel to the flow assembly so that node cables can reach the connectors on the bus bar.

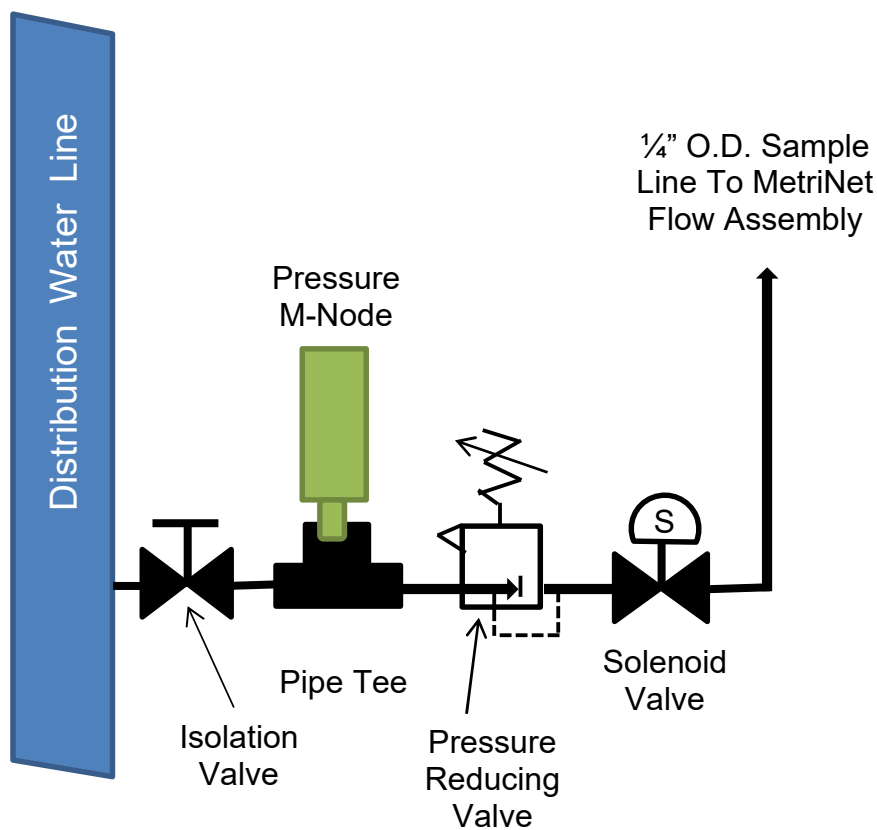

**Figure 9 - Sensor Bus Bar Interface**

### 3.6 Sample Connection

Flow systems are designed to use ¼” OD polyurethane or other semi-rigid tubing. Sample is normally coming from pressurized water pipe and flow systems can handle sample pressures as high as 100 PSIG. However, we recommend that inlet pressure be reduced to about 30 PSI if source water pressure is above 60 PSI. A typical sample arrangement is shown in Figure 5 below. It consists of a shutoff valve, an optional tee with Pressure Node, and pressure reducer. The optional flow control solenoid is also shown, followed by tubing connection to the flowcell. If a pressure sensor is to be used in the *MetriNet* system, it should be installed between the shutoff valve and the pressure regulator as shown in order to properly measure line pressure.

If pressure measurement is not needed and flow control is not used, your sampling system would only consist of an isolation valve and pressure regulator. Even the pressure regulator may not be required when monitoring lines that don’t exceed 60 PSI (4 bar).



**Figure 10 – Typical Installation Sample Connection**

### 3.7 Intermittent Sampling, Cycle Mode

Water samples for MetriNet systems often run continuously, controlled at 200 ml/min. by a flow control device in the outlet assembly. However, the MetriNet controller can turn on flow intermittently to greatly reduce water consumption, operating in “Cycle Mode” as opposed to “Continuous Mode.”

In Cycle Mode, an optional latching solenoid valve is available for this purpose. The solenoid valve is located after the pressure regulator as shown in Figure 10 and is wired to terminals inside the controller. When used, sample flows from the pipe for a short time prior to sensor measurements being recorded. The exact amount of time depends on sample line length but can reduce water consumption from 75 gallons per day down to 5 or 10% of that value depending on the frequency of measurement. The Cycle mode is used to either extend battery life, reduce sample water consumption, or both. Reduction in sample water consumption requires the use of an external latching solenoid valve available from ATI under part number 36-0067.

When a MetriNet controller is programmed for Cycle mode, operation of the measuring system is intermittent. During part of the cycle, all sensors are powered down and the controller is in “sleep mode”. The linear events of Cycle Mode operating are defined as follows. These appear as menus in the CONFIG listing –

- ^Poll Rate, Definition of complete cycle period length.**
- ^Valve Delay, Wait-time after solenoid opens. Allows for stabilization of flow.**
- ^PU Delay, Power up time of sensors prior to an actual reading.**

During an operation cycle, the controller remains in sleep mode until a measurement is required at the poll rate period start time. At that time, if a solenoid is in the system, the solenoid opens to allow sample to flow for the time entered in Valve Delay. The solenoid change of state happens in 200 ms by a pulse, so power is still very low when it changes state. After the value of Valve delay expires, sensors are powered up and the P-U Delay period begins. P-U Delay is the power-up delay. This is the time during which measurement nodes are energized so that a measurement may be made on the flowing sample. At the end of that period, a measured data point is stored, nodes are again powered down, and the solenoid valve is closed (if used). The line diagram below shows a typical sequence schematically.

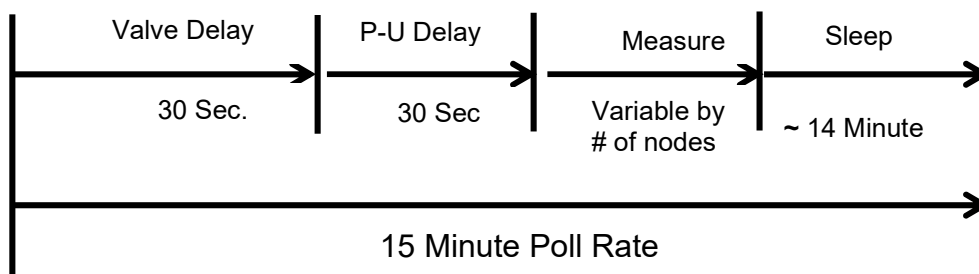

**Figure 11 – Cycle Mode Schematic**

The purpose of the valve delay is to ensure that sensing nodes are exposed to fresh sample for a long enough period of time to get good measurements. For systems where flow is continuous, the valve delay setting should simply be left at the lowest value.



If a system is using solenoid flow control, be sure that the valve delay is long enough so that fresh sample reaches sensors for at least 30 seconds. For estimating the required time, you must take into account the length of your sample line. Using standard 1/4" O.D. polyurethane tubing, you will need approximately 1 second for every 1 foot (3 seconds per meter) of sample tubing from the source pipe to the flow assembly. Assuming you have a 20 ft. sample line, you will need a valve delay of 20 + 30 or a total of 50 seconds in order to ensure that sensors have seen fresh sample for at least 30 seconds prior to measurement.

### 3.8 Electrical Connections

There are only a few connections required for installation of a MetriNet system. All connections are in the controller and the main communication cable connection is made at the factory during testing. Customer connections are DC power and the external solenoid valve, if that option is used.

Figure 12 below identifies DC connection terminals as well as terminals for the sensor bus and optional external solenoid. Note that controllers are supplied with only 2 cable glands installed. A third cable gland is supplied but not installed. The red plug on the bottom can be removed to install the additional gland. That gland will accommodate 2 cables, one for the solenoid wiring and a second for an external trigger. If only one hole is used, put a short piece of cable in the second hole to act as a seal.

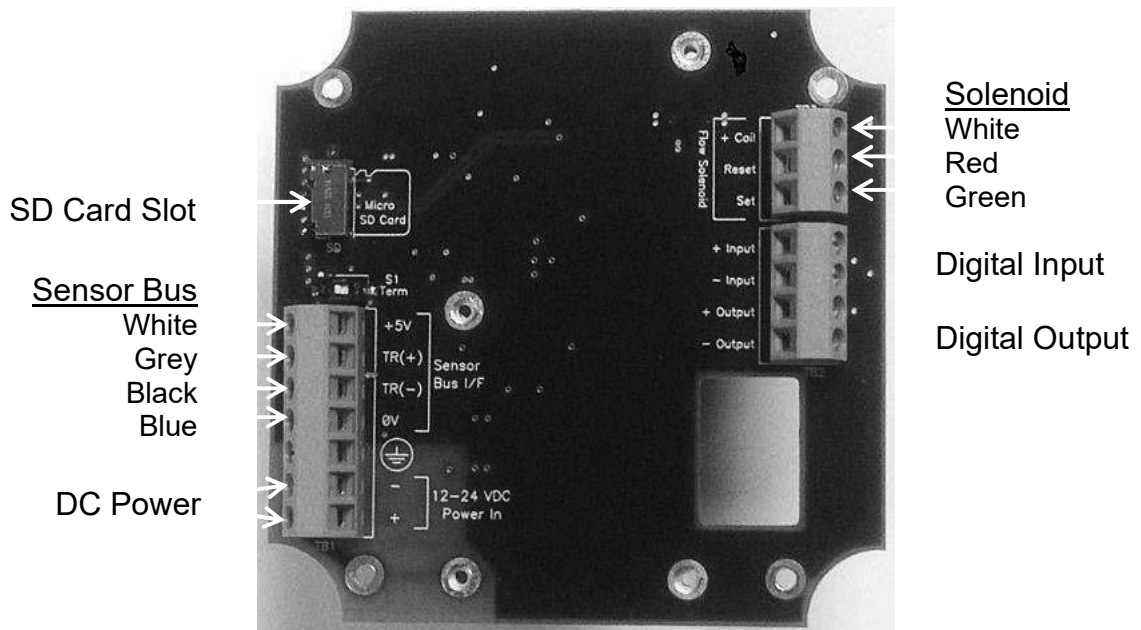

**Figure 12 – External Connections**

MetriNet controllers are powered from either a local 12-24 VDC power supply or from a battery pack. Controllers designed for 12-24 VDC should be used on installations powered with either an external power supply or a battery system connected to a float charger. Battery powered controllers should only be connected to battery packs. These units are designed for minimum power consumption and some protective components have been removed.

### 3.81 Digital Input

Under some conditions, a user may wish to initiate a measurement cycle using an externally generated contact closure. As an example, an alarm from another device might be used to tell the MetriNet controller to take a reading. Digital input terminals are provided for that purpose.

### 3.82 Digital Output

A digital output is available to provide an external indication of an alarm condition. The output toggles on and off in parallel with the backlight flash function. This output will toggle even if the backlight is programmed to OFF.

### 3.83 General Power Overview

MetriNet components are designed to minimize power usage. The total amount of power used depends on the number of M-Nodes used, whether operation is full-power or cycle-power, whether a cellular modem is used, the frequency of call out, and whether the controller is 115VAC, 12-24 VDC or battery only. For systems with a cell modem enabled, predicting the exact usage is not possible due to the wide variation in modem power usage based on cellular signal quality, but here are some guidelines on power usage in the different operating modes.

The MetriNet can be set for “continuous” operation,” or for “cycled operation” in the CONFIG menu (“Cont” or “Cycl.”) Cycled operation is the mode that saves the most amount of power, as the unit sleeps most of the time and only wakes up periodically to take a reading and store data. Continuous operation is intended for applications where non-battery line power is available and measurement frequency is higher, perhaps every minute. Table 12 below summarizes the various general power configurations. Note that all cases are in “steady state,” so measurements reflect at least 3 minutes after power is first applied. **Also, sleep modes only reach low power state if no key has been touched for at least 30 seconds. Touching any key wakes unit up.**

<u>System Type</u>	<u>ON Always, Full Power Mode (12V)</u>	<u>ON/OFF, CYCL Mode (12V)</u>
12-24 VDC with modem, Backlight ON, SD IN	24 mA + 3 mA/node, ON Always	23 mA + 3 mA/node, ON Cycle 21 mA, OFF Cycle
12-24 VDC without modem, Backlight ON, SD IN	24 mA + 3 mA/node, ON Always	23 mA + 3 mA/node, ON Cycle 21 mA, OFF Cycle
12 V battery with modem Backlight OFF, SD OUT	6 mA + 3 mA/node, ON Always	3 mA + 3 mA/node, ON Cycle <b>1.3 mA, OFF Cycle (sleep)</b>
12 V battery without modem Backlight OFF, SD OUT	6 mA + 3 mA/node, ON Always	3 mA + 3 mA/node, ON Cycle <b>1.3 mA, OFF Cycle (sleep)</b>

**Figure 13 – General MetriNet Power**

In addition to the mode setting, the MetriNet can be ordered with either the 12VDC battery board, or with the 12-24VDC DC-DC isolated converter board. The 12VDC battery board is not isolated and is intended only for use with an external 12VDC battery pack. It provides the optimum power savings from battery packs. The 12-24VDC converter board is intended more for line power continuous operation systems. It provides maximum protection from external power supplies, isolation, and allows a wider range of input voltage. This power option consumes considerably more power and is therefore not really intended for battery usage.

**NOTE – When power is first applied to the instrument, the modem powers up and configures itself, so current consumption is high. If making active current measurements, you must wait about 2 minutes after power is first applied to see the true steady state current.**

### 3.84 Power in 115VAC Unit

In this version of the panelized MetriNet, ATI adds its own AC-DC power supply to the panel. The MetriNet itself utilizes the DC-DC converter, and power is not critical so it is assumed the unit is set for continuous operation. Maximum power is about 6W, or 52 mA @115VAC.

### 3.85 Power in 12-24VDC Unit

In this version, the MetriNet generally consumes the same amount of base power continuously. This mode of operation is based on the 12-24VDC converter version to provide isolation, maximum spike/surge protection, and a wide input voltage range. Although base power is continuous, there is a brief increase in power during a cellular transmission. The user frequency of that transmission does affect average power.

**A-Run Power (backlight ON)** - At 12VDC, the MetriNet will consume 24 mA + 3 mA/node

**B-Modem Power** – At 12VDC, the modem consumes 100 mA for a few minutes at each call.

So, assume the user sets the modem to upload all data twice per day, and therefore the modem consumes about 100 mA@12VDC for 2 minutes on each call. This intermittent modem transmission power over 24 hours can be added to the base power to get the average continuous power.

Average power of “pulsed” 100 mA modem twice per day for 2 minutes – 3.33 mW per day

Average power of base run mode with one sensor (27 mA x 12 VDC) - 324 mW per day

Total average power = 3.33 + 324 = **327 mW, or 27.3 mA average @ 12VDC**

You can see here that the modem power at only 2 uploads per day has very little impact on the total average power of this system. Even doubling the number of call-ins to 4 times a day will have very little impact on power increase. Each additional sensor will add 36 mW to the average power calculation.

### 3.86 Power in 12VDC Battery Unit

In this mode of operation, the MetriNet consumes maximum power only when it is “awake,” and then only a small amount of power when sleeping. The system sleeps most of the time.

Backlight is OFF in this mode, and SD card is removed. To calculate power, you need to determine the “average” power over time using the user set cycle settings. Here is an example based on a 15-minute cycle time (poll rate is 15 mins.) This system is also available with a flow solenoid, so that will be part of the calculation here.

**A-Sleep Power** - At 12VDC, sleep current for the entire system is extremely low at 1.3 mADC, so about 15.6 mW. Sensors are not powered at all during sleep mode.

**B-Run Power (backlight OFF, no SD installed)** - At 12VDC, run current for the entire system is about 3.5 mA + 3 mA/node, but that power only appears for 30 seconds every 15 minutes.

**C-Solenoid Power** - At 12VDC, the flow solenoids is pulse driven for only an instant, 2A @ 200 ms) to change state. The solenoid is used to limit water loss.

**D-Modem Power** – At 12VDC, the modem consumes 100 mA max for about 2 minutes max at each call.

Assume user sets the following cycle settings on a system with 1 sensor –

- Modem uploads twice per day (not shown in Fig 14 below)
- Poll rate 15 minutes. Sensor power-up and measurement rate.
- PU delay 30 seconds, On-time of sensors once powered up.
- Solenoid delay 30 seconds, Wait time after solenoid changes state

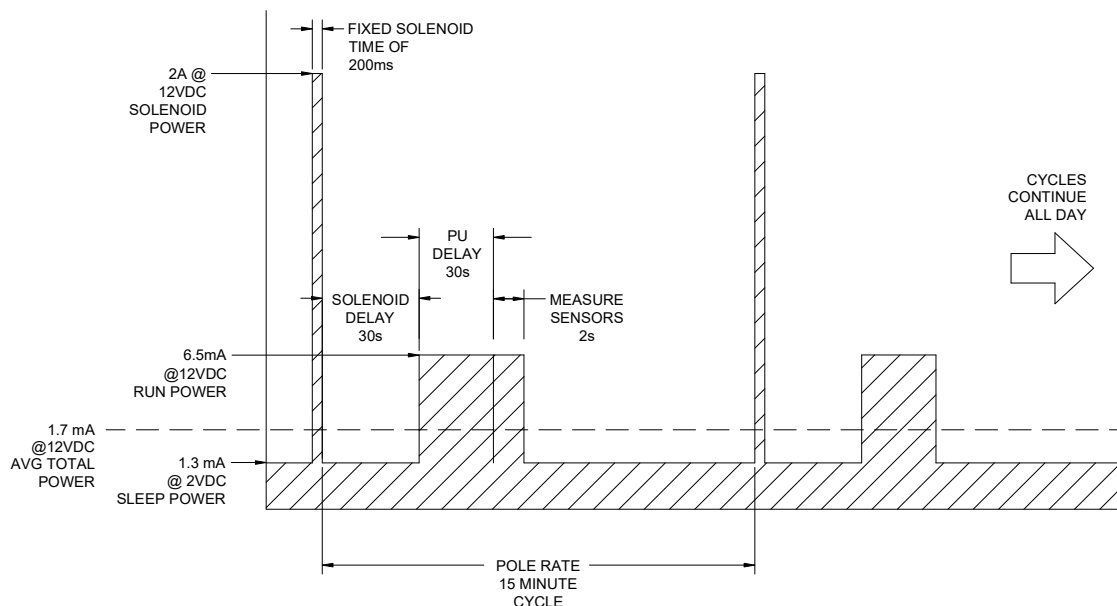

**Figure 14 – Average vs Pulse Power, and State Diagram**

Using pulse-power calculations to get average power...

<https://www.vishay.com/resistors/pulse-energy-calculator/>

Average power of “pulsed” modem calling in twice per day for 2 minutes – 3.33 mW per day

Average power of 30 second “pulsed” run mode w/1 sensor – 1.2 mW per day

Average power of 14 minutes of Sleep mode (1.3 mA x 12 VDC) – 15.6 mW per day

Total average power = 3.33 + 1.2 + 15.6 = **20.1 mW, or 1.7 mADC average @ 12VDC**

### 3.87 Battery Pack Sizing

For the cycled battery mode MetriNet, the calculations of section 3.86 can be used to estimate the size of the battery required for the desired run time.

For example, one of the variations of the MetriNet is available directly with 8 common alkaline D-cell batteries, each with 19 Ahr of available power. This represents a power source of about 12VDC @ 19 Ahr total.  $19000 \text{ mAh}/1.7 \text{ mA} = 11176 \text{ Hours}$ , or about 465 days – **roughly 16 months of operation on this 8-cell battery pack with the settings in section 3.86.**

So, realistically, over a year of operation can conservatively be expected under the following conditions ...

- Battery power board installed
- 12V 19000 mAh power source
- LTE-M modem (standard)
- Cycle mode operation, backlight OFF, no SD installed
- One sensor
- Calling in only twice per day to upload all collected data
- Measuring for only 30 seconds every 15.

Adding sensors, increasing the number up uploads per day, or increasing the frequency of measurement all have an impact on power usage over time. These deviations can be roughly calculated using the information above. As an example - Using all the same settings, adding two more sensors (3 total) increases average power by an additional 2.4mW, which ultimately reduces battery run time to 416 days vs 465 days. **Powering up sensors longer, and uploading more often, have the biggest impact on power consumption.**

### 3.88 Installation Site Factors

While things like the number of sensors can be easily adjusted in these power calculations above, as well as the frequency of call-ins and the actual cycle measurement time of the sensors, modem signal quality does play a large role at some point. You can see with two call-ins per day, the 7.5 mW average power from the modem is about 10% of the calculated total power. So increasing call-in frequency has a much bigger impact to the lower average power of the cycled system.

However, another thing that cannot be easily shown here is the “quality” of the cellular connection, often related to distance to the nearest cell tower. If the cell modem has a difficult time calling in, the MetriNet will automatically do two things –

1-It will retry three times and then simply continue to log data until the next scheduled call-in. No data is lost. At the next call-in, it will try again three times, and continue the process.

2-It will automatically adjust modem cellular transmission power in an attempt to overcome weak signals.

So, while collected data is protected, these efforts dramatically increased call-in attempts can consume a lot of battery power. To prevent these problems, the site should be evaluated carefully during installation to determine good cellular quality. In addition, the MetriNet reports cellular signal strength and battery level in the area in the uploaded data file, so the user can quickly see that connections are a problem in a particular location – and adjust position if necessary.

### 3.9 M-Node Preparation

Sensor nodes are packed individually and some require preparation prior to use. Some require removal of a wetting cap and some simply require installation into the flow chamber. The table below provides guidance.

**Instructions for preparing individual sensor nodes are provided separately, as are the calibration instructions for that node.**

<u>Parameter</u>	<u>Preparation Required</u>	<u>Calibration</u>
Free Chlorine	Membrane & Electrolyte	After startup
Combined Chlorine	Membrane & Electrolyte	After startup
Turbidity	None	Before startup
pH	Remove wetting cap	Before startup
Conductivity	None	Before startup
ORP	Remove wetting cap	Before startup
Dissolved Oxygen	Membrane & Electrolyte	Before startup
Fluoride	Remove cap	Before startup
Dissolved Ozone	Membrane & Electrolyte	After startup
Chlorine Dioxide	Membrane & Electrolyte	After startup
Peracetic Acid	Membrane & Electrolyte	After startup
Hydrogen Peroxide	Membrane & Electrolyte	After startup
Pressure	None	Not Required

### 3.10 Node Installation

Do not install nodes until sample has been connected to the flow chamber assembly and you are ready to turn on the sample flow. When ready, install a node in each chamber, aligning the pins and pressing them into the chamber. Once inserted, turn about 90 degrees to lock in place.

For systems that include conductivity as part of a multi-node assembly, it is best to put the conductivity sensor in the first flow chamber. This ensures that any small amounts of electrolyte leakage from other sensors do not affect the conductivity measurement.

# Part 4 – Operation

## 4.1 General

Check to see that sample is running through the flow assembly. Sample flow is controlled at 200 ml./min. If the system was not purchased with the flow control element, adjust the flow through the system with a valve placed on the outlet side of the flow assembly. Recheck all wiring and verify that the power supply is in the range of 12-24 VDC for external DC systems, and 12VDC for battery systems. Note that battery powered systems will run from 12VDC down to about 7 VDC. The controller does not contain a power switch. It will operate as soon as DC power is applied. Once power is applied, the system will go through an initialization routine and then will begin to operate.

## 4.2 Controller Interface

The user interface for the MetriNet controller consists of a custom display and a membrane keypad. All functions are accessed from this user interface.

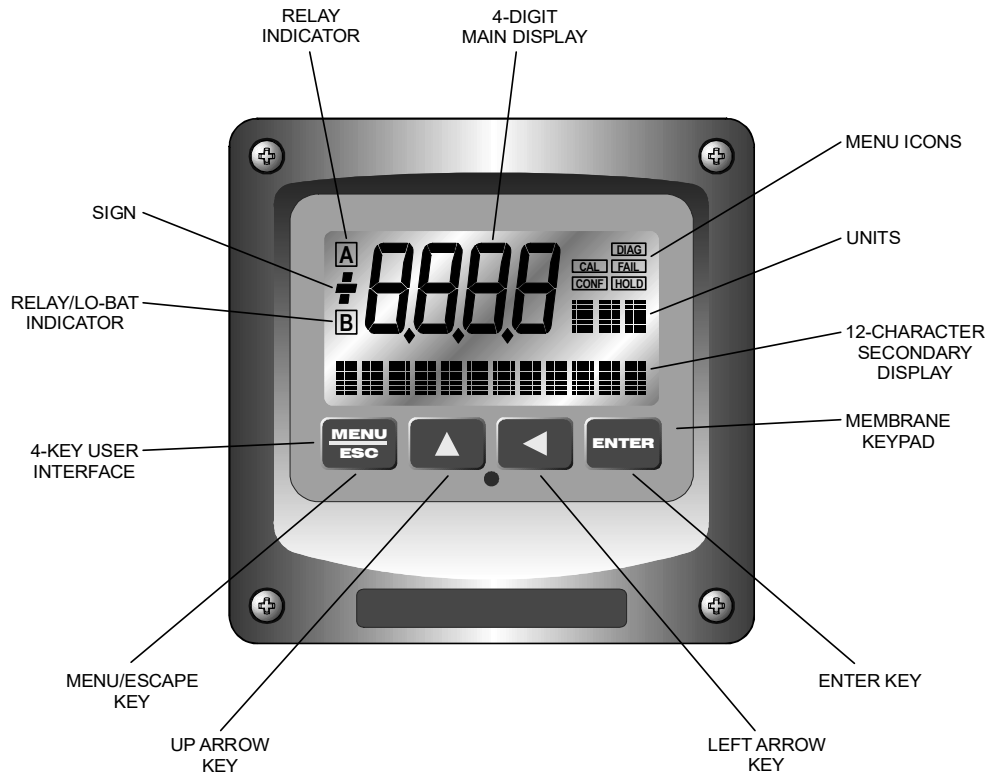

**Figure 15 – MetriNet Controller Interface**

### 4.3 M-Node Assignment

Each measurement node must have a unique sensor number. By default, all sensors are shipped at address #1. If there is more than one sensor in your system, a new sensor number must be assigned to each additional sensor, 1-8. For fully assembled systems, sensor numbers are set at the factory. For other systems, use the following procedure.

**NOTE:** *Only 1 node may be connected to the controller during this procedure. Connect each node separately to assign a sensor number and then disconnect it prior to connecting another.*

1. Press Menu key to access CONFIG menu.
2. Press ▲ key until lower line display shows “Total Snsr”.
3. Press Enter and the main number on the display will flash.
4. Use the ▲ key to adjust the flashing number to the total number of sensors in your system and then press Enter.
5. Press the ▲ key 3 times to access “Addr Snsr” and then press Enter.
6. The display will flash “NO”. Press ▲ once for “YES” and press Enter.
7. The controller will show the current sensor number assigned to that node and it will be flashing. Use the ▲ key to set the required sensor number and press Enter.
8. Repeat steps 1-7 for each M-Node in the system until you have assigned a unique number to each one.

After each sensor has been assigned a unique number, connect all nodes to the bus bar. The controller will now be able to communicate with all nodes.

### 4.4 Controller Programming

The MetriNet controller is used to calibrate the measurement nodes, to store data supplied by the nodes, and to communicate the stored data to the outside world. The nodes are really independent analyzers, measuring a water quality parameter and feeding the data back to the controller. Data is stored in non-volatile flash memory, and then transmitted by cellular modem to cloud storage sites.

The controller program is organized into MEASURE, INFO, SENSOR, CONFIG, and OPTIONS menus. The software map on the following page lists those menus and the sub-menus below each of them.



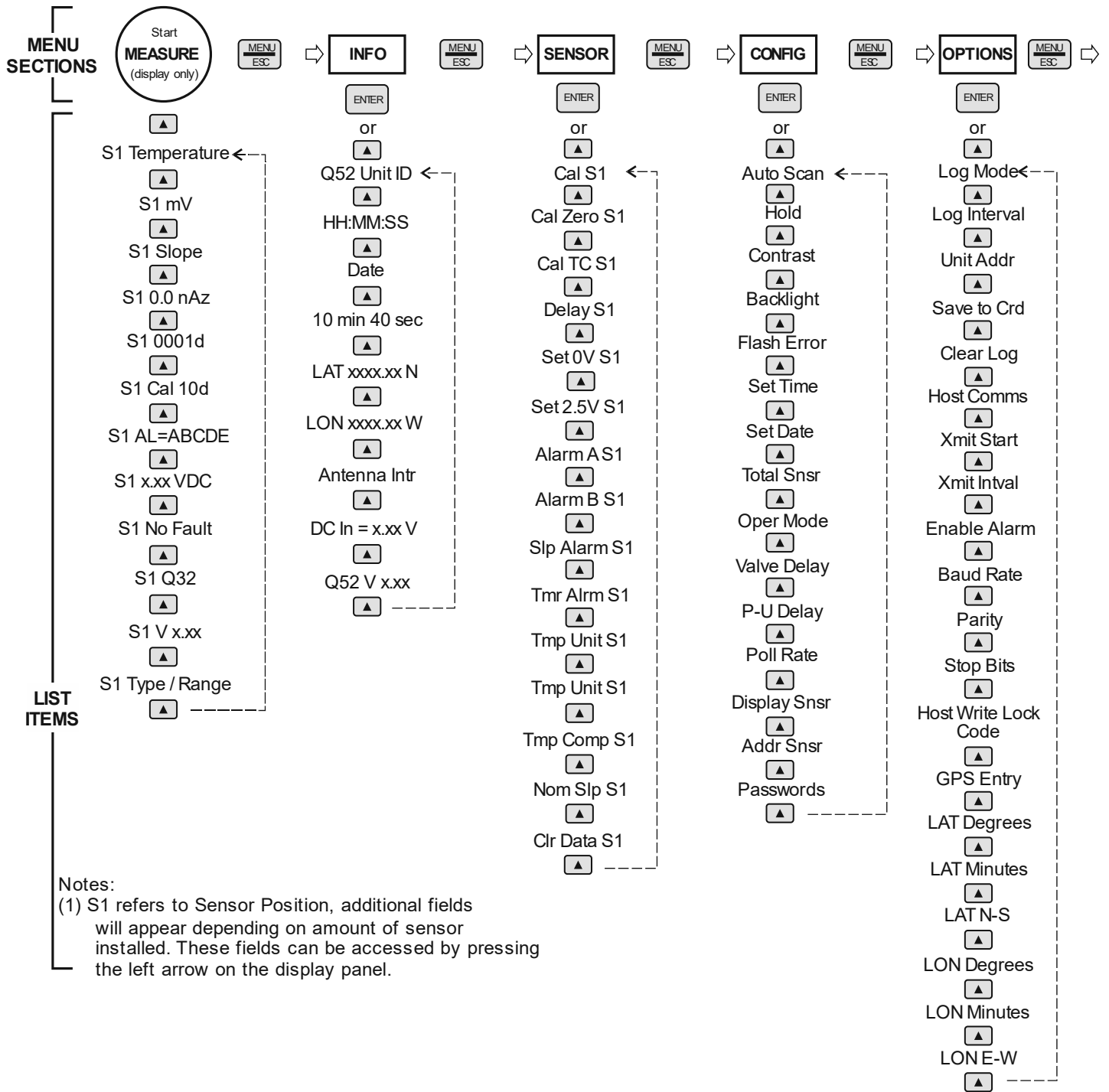

Figure 16 – Controller Software Map

### 4.41 MEASURE Menu

The default controller menu is MEASURE. This menu is display-only. When left alone, the unit will return to the MEASURE menu after 30 minutes. Note that the main display variable will scan through each node automatically. The lower line information applies to the node currently displayed. To stop the scan and look at information on an individual node, press the ◀ key. The scan will stop for 30 minutes but you can advance through each node using the ◀ key.

After selecting the node you wish to look at, use the ▲ key to scroll through variables on the lower display line. The information is not exactly the same for every node but includes the following.

**NOTE:** The S1 designation means sensor #1 and will change for each sensor.

<b>S1 25.7°C</b>	Temperature display. Can be displayed in °C or °F, depending on user selection.
<b>S1 32.0 nA</b>	Raw sensor data. Could be mA, mv., or other.
<b>S1 100%</b>	Sensor output response vs. ideal calibration. Also referred to as sensor “slope” and indicates sensor condition. Value updates after each calibration
<b>S1 0.0 nAz</b>	Sensor output current at a zero ppm input. Value updates after a zero-calibration.
<b>S1 0001d</b>	Sensor life run-time in days. Indicates how long the sensor has been in operation.
<b>S1 Cal 10d</b>	Calibration timer. Indicates number of days since last calibration.
<b>S1 AL=ABCDE</b>	Alarm indicator. Shows which alarms are active.
<b>S1 2.50VDC</b>	Sensor voltage output.
<b>S1 No Fault</b>	Sensor fail message to define detected fault condition.
<b>S1 Q32H0</b>	Sensor type code.
<b>S1 VX.XX</b>	Sensor firmware version
<b>S1 Res Clr/0-5.00</b>	Identifies type of measurement and overall range. Display alternates between measurement type and range. On some sensors, this field can be edited with the Q51 portable calibrator. This allows unique text to be inserted for each sensor. See the Q51 calibrator manual, or the specific sensor Q31/Q32 manual for more details.

#### 4.42 INFO Menu

The INFO menu provides some basic information on the MetriNet controller, also called the Q52. These menu items are for reference only.

<b>Q52 UNIT 10</b>	Specific ID of this Q52. User set.
<b>13:59:40</b>	Hour/Minute/Sec time. 24 hour format.
<b>Dec 31, 2016</b>	Current date
<b>10min 40sec</b>	Time until next data point is recorded. Useful if you wish to perform service before next logged data point.
<b>LAT 1234.56N</b>	GPS entered latitude position
<b>LON 1234.56W</b>	GPS entered longitude position
<b>DC In = 12.1</b>	Measured DC input voltage (from battery or power supply)
<b>Q52 Ver X.XX</b>	Q52 software version number

#### 4.43 SENSOR Menu

The SENSOR menu provides all M-Node information and calibration controls. This menu information largely originates from sensor memory and there is some variation from sensor type to sensor type. The information on typical displays use a free chlorine sensor as an example. See the specific Q32/Q31 sensor manual for the listing of the SENSOR menu.

The routines outlined below allow users to adjust various parameters and calibrate sensors. When making adjustments, pressing Enter will normally start the process. Values may be adjusted using the ▲ and ◀ keys. Pressing Enter again will accept the changes. Pressing Menu/Esc during a routine will cancel the adjustment and go back to the starting screen.

<b>Cal Chlr S1</b>	Calibration routine for sensor span adjustment
<b>Cal Zero S1</b>	Calibration routine for sensor zero adjustment
<b>Cal TC S1</b>	Temperature calibration routine
<b>Delay S1</b>	Routine for adjustment of sensor “damping” or response time
<b>Set 0V S1</b>	Routine to adjust zero value for 0-2.5 V output. No adjustment necessary for sensors used with MetriNet systems. Used to set up sensors for other applications.
<b>Set 2.5V S1</b>	Routine to adjust full scale value for 0-2.5 V output. No adjustment necessary for sensors used with MetriNet systems. Used to set up sensors for other applications.
<b>Alarm A S1</b>	Setpoint for Alarm A. User may define an alarm limit above which the A alarm will be shown in the MEASURE menu.

<b>Alarm B S1</b>	Setpoint for Alarm B. User may define a second alarm limit above which the B alarm will be shown in the MEASURE menu.
<b>Slp Alm S1</b>	User may define a “slope” alarm limit. If the sensor slope falls below that limit after a calibration, Alarm C is shown in the MEASURE menu.
<b>Tmr Alm S1</b>	User may define an alarm limit for the time between calibrations. If a calibration is not done within the defined time period, Alarm D is shown in the MEASURE menu.
<b>Tmp Unit S1</b>	Allows temperature reading in degrees C or degrees F.
<b>Tmp Comp S1</b>	Allows modification of sensor temperature compensation.
<b>Nom Slp S1</b>	Normalizes slope to 100%. May be done after a sensor has been serviced and calibrated for the first time. Does not affect calibration, and is only used to set a nominal 100% point for slope alarm. Generally, leave this setting as is.
<b>Clr Data S1</b>	Resets all sensor stored data to factory default values.

#### 4.44 CONFIG Menu

The CONFIG menu provides access to Q52 controller configuration settings. Routines defined here are not sensor specific. They define the overall function of the controller.

<b>Auto Scan</b>	Turns sensor scanning on and off. When ON, each sensor value is displayed for 4 seconds.
<b>Hold</b>	Freezes data being written to the data logger. Useful when sensor calibration or service is needed.
<b>Contrast</b>	Used to adjust LCD contrast. Default is 7. Range is 1-8.
<b>Backlight</b>	Turns LCD backlight on and off. Turn off when operating from battery power.
<b>Flash Error</b>	Programs LCD backlight to flash if an error is detected. Select “All” to flash on any sensor error. Select Sn9I (single) to flash display only when the sensor causing the error is displayed.
<b>Set Time</b>	Used to program current time. After pressing Enter, use a combination of the ▲ and Enter keys to adjust hours, minutes, and AM/PM.
<b>Set Date</b>	Used to program current date. After pressing Enter, use a combination of the ▲ and Enter keys to adjust year, month, and day.
<b>Total Snsr</b>	Defines how many sensor nodes are connected to the controller.
<b>Power Mode</b>	Defines whether the controller runs continuously (Cont) or only intermittently (CYCL). When operating from battery power, cyclic operation greatly reduces power consumption. In addition, an external solenoid may be controlled in Cycle mode in order to conserve water.

<b>Valve Delay</b>	If the optional solenoid is used to turn flow on and off, the valve delay value defines the delay time, starting from when the solenoid is opened, before sensor nodes are powered up to make measurements. Delay time depends on length of sample lines. Delay may be set from 1-99 seconds.
<b>P-U Delay</b>	When in CYCL mode, P-U delay defines the time period after the nodes are energized until the controller polls the nodes for data. Range is 1-99 seconds.
<b>Poll Rate</b>	When in CYCL mode, this defines the rate at which data will be recorded. In other words, this is the cycle rate. Range is 1-99 minutes.
<b>Display Snsr</b>	Tests communication to each sensor. Press Enter and status of comms for each sensor is tested. Sensor found indicate “Yes” while sensors not found indicate “No”. Press Enter again to exit.
<b>Addr Snsr</b>	Routine used to add sensors to a controller network. Use of this routine is describe in section 4.3 (Node Assignment).
<b>Passwords</b>	Sets a user specified Supervisor password. The default is 0000, which means the password is disabled. Once a supervisor password is set, only those with that code may change the overall system configuration items and option items. After 5 unsuccessful attempts, the unit will lock for 30 minutes. An additional 5 “User” passwords may be assigned by the supervisor. Those assigned a user password may make adjustments to items in the SENSOR menu, such as sensor calibrations. Detailed instructions on setting passwords are found in section 4.5.

#### 4.45    **OPTIONS Menu**

The OPTIONS menu contains settings related to the data logging function and the internal cell modem, Modbus option or Ethernet module option if installed.

<b>Log Mode</b>	Turns the data logger on or off and defines whether logging is continuous or stops when memory is full. If the data logger is shut off, the modem is disabled.
<b>Log Interval</b>	Sets the data storage interval. Range is 0.1 to 99.9 minutes.
<b>Unit Addr</b>	It is best to have a unique address for each. This number is part of the data log and is used to identify the controller that supplied the data. It is also used as the Modbus address if the unit is connected to an external Modbus network. Range is 1-247.
<b>Save to Crd</b>	This routine allows data stored in flash memory to be written to an SD memory card. The SD card is removable for data transfer to a laptop or PC.
<b>Clear Log</b>	This routine clears all data stored in flash memory. Once cleared, it cannot be recovered. Verify that all data has been saved (or is not needed) prior to clearing the log.
<b>Host Comms</b>	Enables internal cell modem or other digital communications interface if installed. For this cellular unit, should be set to “Cell.”

<b>Xmit Start</b>	Defines when the first data transmission by the cell modem will occur. Range is 00-23, 00=midnight, 23=11 PM.
<b>Xmit Intval</b>	Sets the interval between cell modem data transmissions.
<b>Enable Alarm</b>	Enables sending the Alarm Record when the Cell Modem option is installed. Also enables call-on-alarm functionality.
<b>Host Baud Rate</b>	Sets the Baud Rate for the Modbus Interface. 9600 or 19.2K Baud. Only visible for serial Modbus RTU systems.
<b>Host Parity</b>	Sets parity for Modbus interface. None, Even or Odd. Only visible for serial Modbus RTU systems.
<b>Host Stop Bits</b>	Sets number of stop bits for Modbus interface. 1 or 2. Only visible for serial Modbus RTU systems.
<b>Host Write Lock Code</b>	Range is 0 – 9999. Host must write unlock code when calibrating or changing any settings via Modbus interface. Only used for serial Modbus RTU systems.
<b>GPS Entry</b>	Allows auto Capture or Manual entry of GPS Latitude and Longitude Data.
<b>Lat Degrees</b>	Range is 0 – 90. Enter the first two digits (DD) of the Latitude. Format for Latitude is DDMM.MM N/S.
<b>Lat Minutes</b>	Range is 00.00 – 99.00. Enter the next four digits (MM.MM) of the Latitude.
<b>Lat N-S</b>	Enter N for North, enter S for South.
<b>Lon Degrees</b>	Range is 0 – 90. Enter the first three digits (DD) of the Longitude. Format for Longitude is DDDMM.MM E/W
<b>Lon Minutes</b>	Range is 00.00 – 99.00. Enter the next four digits (MM.MM) of the Longitude.
<b>Lon E-W</b>	Enter E for East, enter U for West.

## 4.5 Set Passwords

MetriNet systems are designed with 2 levels of password protection to prevent unauthorized adjustments. There is one Administrator password and up to 5 separate User passwords. All passwords are numerical, consisting of 4 digit numbers.

As shipped, controllers are not password protected. All passwords are disabled and the user must decide whether to use password protection or not. Some of the events recorded in the Event Log are tied to the password entered in order to perform the recorded function.

The Administrator sets the administrator password and programs all user passwords. The following steps are needed to set passwords.

1. Go to OPTIONS Menu and press ▲ repeatedly until bottom line indicates Passwords.
2. Press Enter. Display will show 0000 with right digit flashing. Using the ▲ and ◀ keys, enter a 4-digit supervisor password.
3. Press Enter and that number will be recorded.

## 4.6 Sensor Display

Controller units can display measurements from up to 8 M-Nodes. The display operates either in Auto-Scan or Manual modes. The first routine in the CONFIG menu turns the Auto-Scan function on or off. The default mode is ON. With Auto-Scan on, the display will show the measured value of each node for 4 seconds and then switch to the next one. All measurements may be observed by simply watching the display.

To manually sequence through the nodes, press the ◀ key. The first time the key is pressed, the scanning mode will stop. By pressing the ◀ key repeatedly, you can cycle through all measurements. If no key is activated for 30 minutes, the display will revert to scan mode.

Interrupting the scan mode allows you to look at specific sensor data and do calibrations or other adjustments. When you select a specific sensor using the ◀ key, you can then sequence through the information screens on the bottom line using the ▲ key. The contents of each information screen are summarized in section 4.41.

Once you have selected a specific node, you can go to the SENSOR menu for that node by pressing Menu twice. From the SENSOR menu, you can adjust sensor zero and sensor span, calibrate temperature, set alarms, and adjust other settings as outlined in section 4.43.

**NOTE:** If passwords are enabled, you must enter your password in order to make sensor adjustments.

# Part 5 – Data, Alarm & Event Log

---

## 5.1 General

The primary purpose of a MetriNet system is to monitor water quality parameters and log the data. The data may then be either transmitted to a remote data storage cloud site by modem or collected manually by writing data to the SD RAM card located in the controller. The amount of data depends on the number of sensors used and the logging frequency.

## 5.2 Data File Format

Data is stored internally and transmitted is in a standard .CSV format. Once offloaded, data can be easily displayed and analyzed using Excel or other spreadsheet programs. Shown below is part of a typical data file that has been sent by modem to a storage cloud data site.

When sent to a FTP site, the actual data file name includes unit ID and time stamp to show when and where the file came from. The format of the file name is Data\_Dev\_ID\_YYMMDD\_HHMM where Data indicates it is a data file as opposed to an alarm file, Dev\_ID is the unit address number, Date and Time as entered in the Q52. Time is in 24 hour format.

Other information included in the header of each data file includes:

-**The Radio Model number**, 16 digit Radio IMEI number, and 20 digit SIM Card number.

-**The Signal Level and Bit Error Rate** indicated reported radio signal strength. A value of 10 or more is typical, A Signal level less than 10 may still connect, but may take longer to send data, or intermittently have problems calling out.

-**The Supply Voltage** is the measured DC voltage powering the Q52. For battery powered systems, this provides the user with an indication of battery charge status and can be used to know when it is time to change out or charge a battery pack.

-**The Latitude and Longitude** displays the physical location of the unit. This may be captured location data or manually enter values.



Data Record										
Radio Model	HE910-D									
IMEI Number	35613607	4512551								
SIM Number	89011702	27202478	6805							
Signal Level	11									
Bit Error Rate	3									
Supply Voltage	12.1									
Latitude	5453.34N									
Longitude	8531.52W									
Date	HH:MM:SS	Temp	Sensor 1	Sensor 2	Sensor 3	Sensor 4	Sensor 5	Sensor 6	Sensor 7	Sensor 8
9/23/2018	15:10:58	26040	2374	7000	13040	1000	0	0	0	0
9/23/2018	15:25:58	26130	2368	7000	13030	1000	0	0	0	0
9/23/2018	15:40:58	26190	2364	7000	13030	1000	0	0	0	0
9/23/2018	15:55:58	26410	2349	7000	13040	1000	0	0	0	0
9/23/2018	16:10:58	26430	2348	7000	13020	1000	0	0	0	0
9/23/2018	16:25:58	26600	2336	7000	13000	1000	0	0	0	0
9/23/2018	16:40:58	26640	2334	7000	12990	1000	0	0	0	0
9/23/2018	16:55:58	26700	2330	7000	13020	1000	0	0	0	0
9/23/2018	17:10:58	26670	2332	7000	13020	1000	0	0	0	0
9/23/2018	17:25:58	26640	2334	7000	13020	1000	0	0	0	0
9/23/2018	17:40:58	26630	2334	7000	13010	1000	0	0	0	0
9/23/2018	17:55:58	26550	2339	7000	13020	1000	0	0	0	0
9/23/2018	18:10:58	26480	2344	7000	13010	1000	0	0	0	0
9/23/2018	18:25:58	26480	2344	7000	13020	1000	0	0	0	0
9/23/2018	18:40:58	26430	2348	7000	13010	1000	0	0	0	0
9/23/2018	18:55:58	26430	2348	7000	13010	1000	0	0	0	0

**Figure 17 – Stored Raw Measured Data Format**

All data is stored as 16-bit data with 4 decimal resolution. In order to convert raw data to actual engineering units, simply divide each value by 1000. Since each controller can accommodate up to 8 nodes, zero values are stored for each unused sensor input. Data manipulation such as appending files and generating graphical reports is left to the user.

### 5.3 Alarm File Format

In addition to the data log CSV file, the controller also generates an alarm log file. The alarm file format is similar to the data file format. When copied to the SD Card, the file name is Q52ALnnn where nnn is the unit address number. The alarm file logs an alarm event any time one of the sensor setpoints A or B changes state. If communications are lost to a sensor, Error is shown. The time stamp shows when the alarm occurred. Up to 200 alarm events may be stored.

While this file is generated as alarms happen, the file is not uploaded via the cellular modem unless menu “Enable Alarm” is ON. If enabled, the MetriNet will immediately call out on alarm, and not wait for the next scheduled upload. So, alarm events are handled with very high priority.

To prevent nuisance uploads (excessive uploads) and excessive power consumption, once a sensor alarms, the system will not continue to call in repeatedly unless an additional sensor alarms. Then, at the regularly scheduled data upload time, the system will check to see if all alarms are cleared, and if so, the system will reset to call in again at the first alarm. The logic of alarm management is designed to prevent excessive call-ins that result in high data handling over cellular (excess SIM charges) and also to maintain battery life.

There is an assumption here that any alarm that is uploaded is also immediately acknowledged and acted up by the user’s data site, as they will know the instant an alarm record appears in the package upload.

Q52 Alarm Record									
Date	HH:MM:SS	Sensor 1	Sensor 2	Sensor 3	Sensor 4	Sensor 5	Sensor 6	Sensor 7	Sensor 8
8/22/2018	1:28:43	OK	OK	OK	OK	0	0	0	0
8/22/2018	21:18:36	A	OK	OK	OK	0	0	0	0
8/22/2018	21:20:58	OK	B	OK	OK	0	0	0	0
8/22/2018	23:09:22	OK	OK	A B	OK	0	0	0	0
8/22/2018	23:23:10	OK	B	A B	OK	0	0	0	0
8/22/2018	23:26:20	OK	OK	AB	OK	0	0	0	0
8/25/2018	20:26:48	OK	OK	OK	OK	0	0	0	0
8/25/2018	20:28:24	OK	OK	OK	Error	0	0	0	0
8/25/2018	21:02:06	OK	OK	OK	OK	0	0	0	0

**Figure 18 – Stored Raw Alarm Data Format**

### 5.4 Event File Format

In addition to the data log file, the controller also generates an event log file. The event file format is similar to the data file format. When copied to the SD Card, the file name is Q52ELnnn where nnn is the unit address number. The event file does not contain a lot of information and many times has nothing at all. However, it is intended to record certain changes as they occur. The following are the events currently stored. Up to 100 events may be stored. This file is not uploaded via cell.

Q52 Event Record				
Supply Voltage	12.1			
Latitude	GPS Off			
Longitude	GPS Off			
Date	HH:MM:SS	Sensor	Event	
9/10/2018	10:57:45	0	EventLog Cleared	
9/10/2018	14:33:43	0	Sup Passwd Entry	
9/10/2018	14:40:25	0	User1 Passwd Entry	

**Figure 19 – Stored Event Data Format**

### 5.5 SD RAM Card

MetriNet controllers contain a micro-SD card slot on the terminal block circuit board just above the bus connections (see photo in section 2.7). As previously mentioned, data is stored in flash memory in the controller. Data can be manually removed by writing the data to a micro-SD card and then removing the card from the controller.

Controllers are supplied with 2 GB SD cards. To retrieve data manually, simply write stored data to the SD card using the “Save to Crd” routine in the OPTIONS menu. Many new computers have micro-SD slots while others will only accept the larger format SD card. An adapter is supplied so that micro-SD cards can be inserted into standard SD card slots.

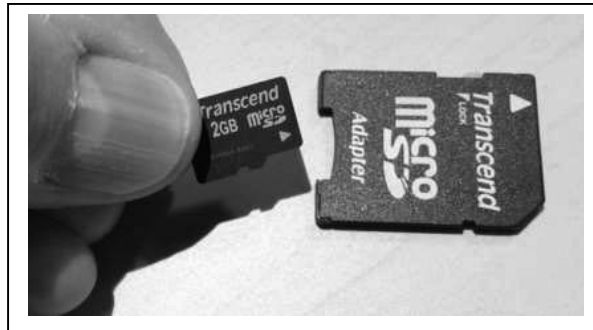

**Figure 20 – Micro-SD Card With Adapter**

## 5.6 Local Data Storage Capacity

MetriNet controllers can store large amounts of data. The time period required to fill the memory depends on how many nodes are connected and how often data is stored. A controller with a maximum of 8 nodes logging data every 6 seconds can store 48 hours of data. That’s about 230,000 data points. A more typical application with 4 M-Nodes taking data once every 10 minutes will hold about 239 days of data.

Data held in flash memory may be recorded until the memory is full or it may be stored in a circular file, with the oldest data overwritten by the newest data once the memory is full. The selection is made in the “Log Mode” routine of the OPTIONS menu. Choosing “Cont” selects a circular file mode of operation. Selecting “Full” stops the data logging when the memory is full.

## 5.7 Transmitted Data

MetriNet controllers are designed to log large amounts valuable data, and then periodically upload that data to a secure cloud data site. The amount of data moved via cellular connection has an impact on the billable data moved each month by the cellular service provider (SIM.) ATI SIMS allow 1M of data total to be moved each month, but more capability is available if needed.

1-Meg of data is more than adequate for a typical logging application, and is enough to store 8 sensors worth of data recording every 5 minutes, and then uploading every 4 hours. The maximum data movement each month for a MetriNet is about 3-4 Meg – assuming 8 sensors worth of data is reordered every minute and uploads occur every hour. So, the user should consider this during installation as unplanned data “overages” can affect monthly billing rates from some cell service providers.

Every time the MetriNet connects with a data file, the following is an estimate of data transfer –  
1-2.5K of overhead for each call. This is the cellular connection/registration data.

2-456 bytes for the info section header of the MetriNet data file.

3-Approximately 70 bytes per line of time stamped data, for 8 sensors, or 44 bytes per line for 4 sensor systems.

So, with the minimum of 2.5K of data moved as overhead for the cell connection and no data file, a MetriNet that calls in twice a data moves about 150K of just connection/registration data per month (5K x 30) just to establish proper connections. The actual sensor data file size simply corresponds to the number of time stamped entries in the file, and the number of sensors recorded.

Some typical examples, all based on the most common 4-sensor systems -

#### **Example 1**

4 sensors of data logged at 15 minute intervals, uploaded every 4 hours. That will result in 16 full time stamped records (lines of measured data) in the data file. So, there are 6 connections and uploads per day.

-So, 6 x 2.5K for cell connection each day = 15K of data

-Each file has 16 lines of data + 456b header, sent 6 times/day.  $(6 \times ((16 \times 44) + 456)) = 7K$

-Each day then equals 15K + 7K = 22K transferred.

-In one month, a total of 30 x 22K = 660K total data transferred each month.

#### **Example 2**

4 sensors of data logged at 5 minute intervals, uploaded every 12 hours. That will result in 16 full time stamped records in data file. So, there are 2 connections and uploads per day.

-So, 2 x 2.5K for cell connection each day = 5K of data

-Each file has 144 lines of data + 456b header, sent 2 times/day.  $(2 \times ((144 \times 44) + 456)) = 13.6K$

-Each day then equals 5K + 13.6K = 18.6K transferred.

-In one month, a total of 30 x 18.6K = 558K total data transferred each month.

Notice that uploading less often greatly reduces SIM data charge as it minimizes the overhead from connection/registration charges of 2.5K per call. Even though the polling rate has increased to 5 minutes, resulting in more data logged - the total data charge per month is less. Even so, both of these cases are well under the standard 1 Meg/month limit.

## **5.8 GPS Function**

MetriNet controllers contain a GPS chip that allows the controller to transmit its position to the data site. This function is mainly useful if you plan to move the system around to different locations. However, it can also be useful if the location of the installation is to be displayed on a mapping program.

The GPS function is accessed using the “GPS Entry” routine in the OPTIONS menu. The GPS data is only acquired when “Search? YES is selected. The GPS Status will be displayed on the lower line of the display. It can take up to 5 minutes to acquire GPS location data.

If a location is found, the lower display will show the Latitude for a few seconds, then display the Longitude for a few seconds, then exit the function. Once the position is acquired, the data will be stored in Flash Memory and need not be updated unless the system is moved to another location.

If a location is not found, current Latitude and Longitude data is preserved, and the display will advance to the “Manual Entry?” Prompt. If YES is selected, the unit will advance to manual entry of Latitude and Longitude data.

The antenna for the GPS chip is internal to the controller and is not a strong receiver. It may be necessary to temporarily activate the controller outdoors at the installation site to get valid data.

# Part 6 – Cellular Setup

## 6.1 SIM Card Installation

MetriNet controllers equipped with cellular modems require a SIM card with data service from a national or global service provider. Systems supplied for evaluation purposes will be delivered with a global SIM card already installed and ready to operate.

For long term installations, users may continue to lease data service from ATI or can arrange their own data services from another supplier. This will require installation of the users SIM card into the MetriNet modem assembly.

NOTE: The actual modem used is determined by the carrier service plan. For operation in North America, ATI recommends using Aeris for the data plan as it is the most cost-effective solution. This plan uses a combination of AT&T and T-Mobile for carrier service. Installing a SIM card from another carrier will not work in a modem designed for use with AT&T or T-Mobile.

To install a SIM card, turn off power and loosen the 4 enclosure screws to access the inside of the controller. Disconnect power and communication cables and remove the antenna from the controller. Place the front of the controller assembly face down and remove the 4 corner screws holding the terminal board in place.

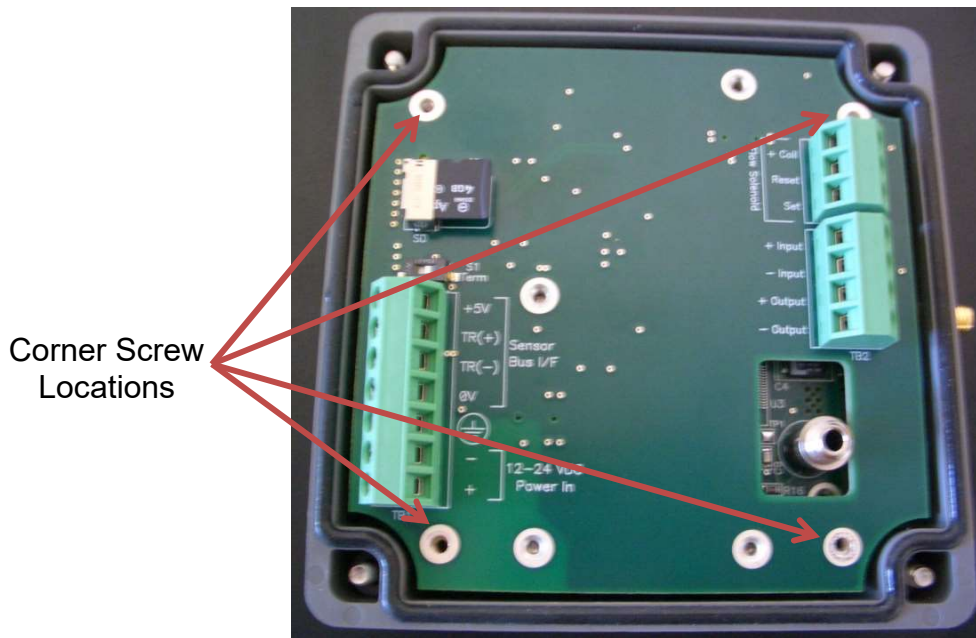

**Figure 21 – MetriNet Rear Panel SIM Access**

Carefully unplug the terminal board/modem assembly from the display board. The terminal board can be disconnected by pulling straight up on the green terminals. Turn the terminal board over and the modem will be accessible as shown below. Remove the current SIM and install your new SIM card. Be careful not to disconnect the antenna cable.



**Figure 22 – MetriNet Cellular Modem Board with SIM Card**

After installing the SIM card, plug the terminal board/modem assembly back into the display board. If you carefully line up the 4 corner screw locations with the standoffs on the display board, the multi-pin connector between the two boards will align properly. If the antenna cable gets disconnected, be sure to plug it back onto the connector labeled “M” (main), not “A” (aux).

## 6.2 Controller Programming

The OPTIONS menu contains all Q52 settings related to the data logging function and the internal cell modem.

<b>Log Mode</b>	Turns the data logger on or off and defines whether logging is continuous or stops when memory is full. If the data logger is shut off, the modem is disabled.
<b>Log Interval</b>	Sets the data storage interval. Range is 0.1 to 99.9 minutes.
<b>Unit Addr</b>	This number is part of the data log file name that is uploaded and is used to identify the controller that supplied the data. It is also used as the Modbus address if the unit is connected to an external Modbus network. Range is 1-247.

---

<b>Clear Log</b>	This routine clears all data stored in flash memory as well as the data that is held in the cell modem flash memory. Once cleared, it cannot be recovered. Verify that all data has been saved (or is not needed) prior to clearing the log.
<b>Host Comms</b>	Enables internal modem or communications interface if installed. Set this to CELL to enable the cell modem option.
<b>Xmit Start</b>	Defines when the first data transmission by modem will occur. Range is 00-23, 00=midnight, 23=11 PM.
<b>Xmit Intval</b>	Sets the interval between modem data transmission.
<b>Alarm Enable</b>	Enables uploading the Alarm Log record.
<b>GPS Entry</b>	Allows auto Capture or Manual entry of GPS Latitude and Longitude Data.
<b>Lat Degrees</b>	Range is 0 – 90. Enter the first two digits (DD) of the Latitude. Format for Latitude is DDMM.MM N/S.
<b>Lat Minutes</b>	Range is 00.00 – 99.00. Enter the next four digits (MM.MM) of the Latitude.
<b>Lat N-S</b>	Enter N for North, enter S for South.
<b>Lon Degrees</b>	Range is 0 – 90. Enter the first three digits (DD) of the Longitude. Format for Longitude is DDDMM.MM E/W
<b>Lon Minutes</b>	Range is 00.00 – 99.00. Enter the next four digits (MM.MM) of the Longitude.
<b>Lon E-W</b>	Enter E for East, enter U for West.

# Part 7 – Cellular Configuration Utility

---

## 7.1 General

The ATI Q52 Utility is a PC application program that is used to setup and configure the MetriNet Cell Modem option for a specific customer application. It also includes diagnostic troubleshooting capability required to assure proper operation or to monitor operation should a problem occur.

Requirements:

Windows based PC

FTDI-232R-3V3-AJ USB Communications Cable

Install the ATI Q52 Utility software on your PC by clicking on the ATI Utility.exe file. The program is available at [www.analyticaltechnology.com](http://www.analyticaltechnology.com) or [www.Wqhub.com](http://www.Wqhub.com). Follow the instructions when prompted to install the program. When you install the utility, it will create an executable file in your Program Files directory. You should find an entry in your directory that looks like this:

"C:\Program Files (x86)\Analytical Technologies\ATI Q52 Utility\ATI Q52 Utility.exe"

## 7.2 Modem Programming

MetriNet systems supplied with cellular modems may already be programmed at the factory to send data to an ATI data site where data can be viewed, stored, and downloaded to your computer via the web. Users may wish to direct data to a site other than the ATI site. This is not a problem provided that your alternate site supports FTP transmission, as many cloud storage sites do.

Redirection of modem data requires that the modem be reprogrammed using the ATI Q52 Utility program. A special cable for connection between the modem and a USB port on your computer is included with each MetriNet controller that contains a cell modem option. This cable has a USB plug on one end and an audio plug to the modem on the other.

**Note: Wait until the serial cable from the PC is plugged into the modem option before powering up the Q52 instrument. Once the modem sees the cable connected, it will stay powered up. Otherwise, the modem option will power down when not sending data, and you may get a communications error.**

Plug the USB cable into a USB port on your PC. The first time you do this, it may take a few minutes to install the device driver. Plug the other end of the serial cable into the jack on the PCB inside the monitor as shown.



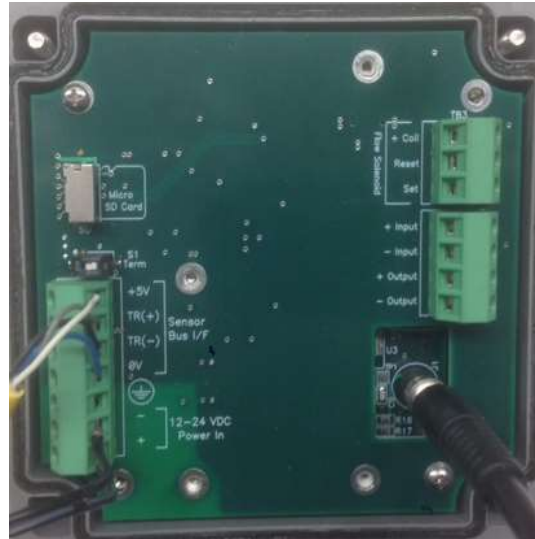

**Figure 23 – MetriNet PC Cable Connection**

Once the device is ready for use, click on the ATI Icon to start the program. The ATI Splash screen will be displayed, then the following window will open.

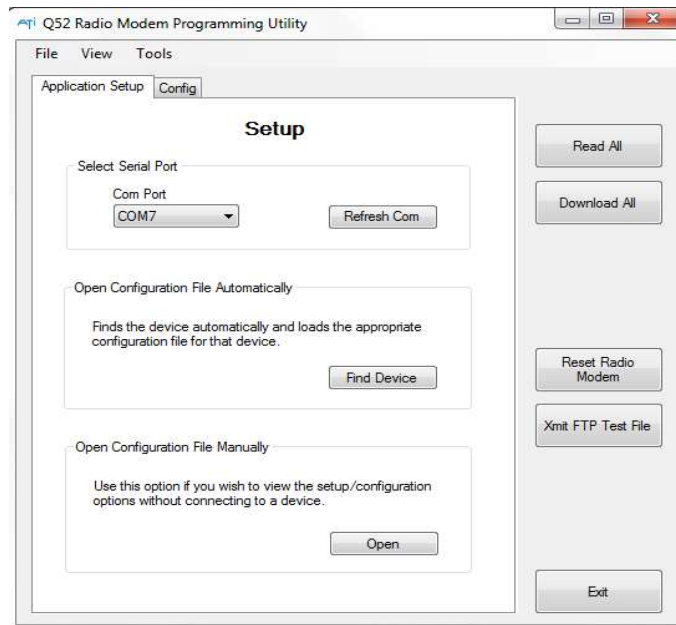

**Figure 24 – PC Utility Connection Screen**

Click on refresh Com List. The program will search for all available Com ports. Then click on the Com Port drop down list and select the com port for the USB cable. If not sure which com port it is, unplug it and click Refresh Com List. Then plug the cable back in and click Refresh Com List again to see what new port appears. Once port appears, clic on the **Find Device** button.

The program will attempt to communicate with the Cell Modem Option. An associated configuration file is loaded. You can also manually select a configuration file by clicking on Open and selecting a configuration file. You must have the correct configuration file for the device and version software running on it. So clicking Find Device will automatically open the correct configuration file. Now click the Read All button. The PC will query the device and display current setup/configuration settings as shown below.

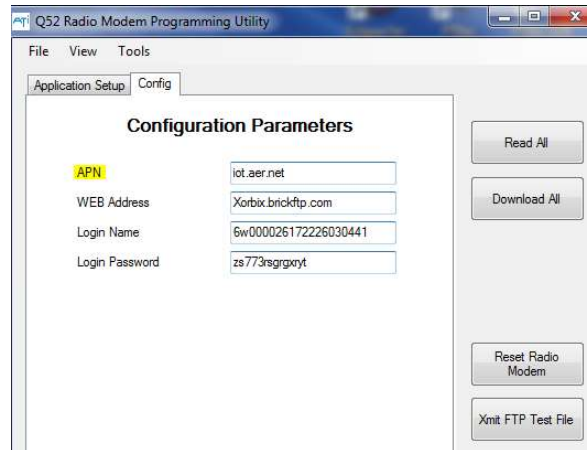

**Figure 25 – PC Utility Config APN Screen**

**APN** is the Access Point Name. This will vary depending upon your data plan provider. For an Aeris SIM card in the United States, the APN is “iot.aer.net”. For an AT&T SIM card in the United States, the APN is “broadband”.

**WEB Address** is the address of the web site you are using to upload data to. This may be up to 40 characters in length.

The **Login Name** and **Login Password** are whatever the WEB site requires to log onto the web site. These are also limited to 40 characters each. After all setup/configuration data has been entered, click on the Download All button. All of the setup data will be downloaded to the Cell Modem Option and stored in flash memory.

### 7.3 WQ Hub Login and Password

If using the WQ Hub web site, the Login Name and Login Passwords are assigned by the WQ Hub web site when the user account is created. To get the password and login information, login into the WQ Hub user account.

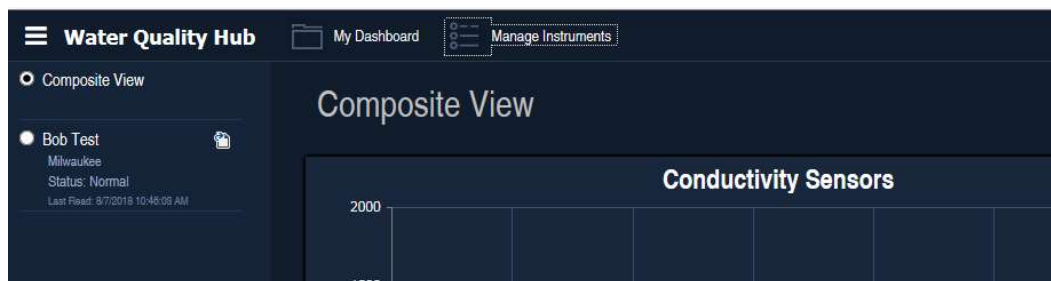

**Figure 26 – WQhub Setup. Manage Instruments Section**

Click on the Manage Instruments ICON. This will bring up the following screen.

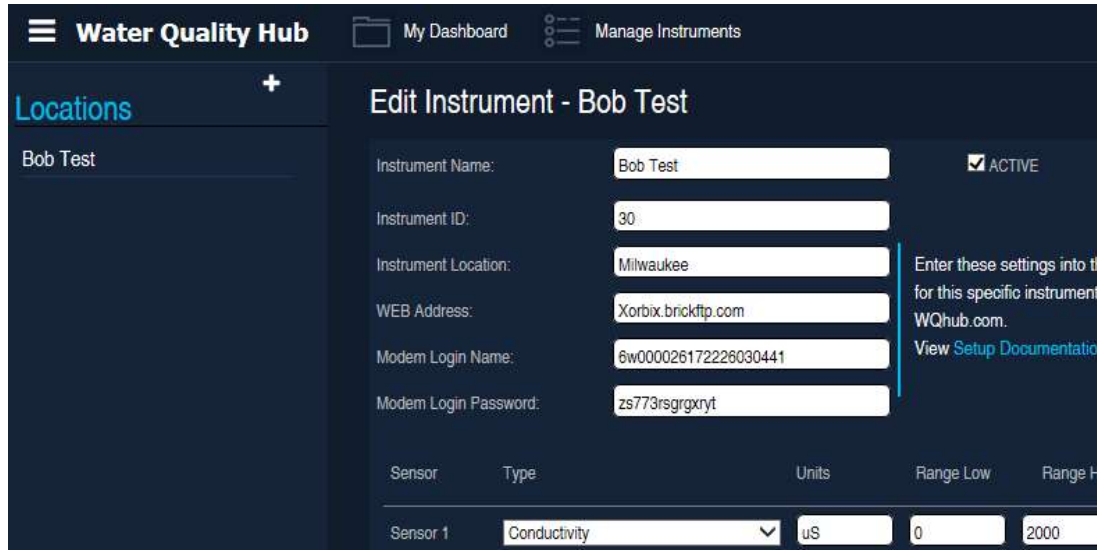
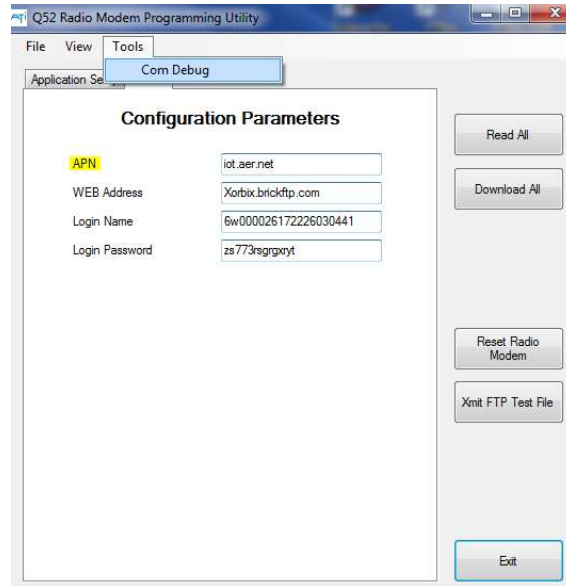

**Figure 27 – WQhub Setup. Instrument Settings.**

Simply cut and paste the Web Address, Modem Login Name and Modem Login Password from this web page into the ATI Q52 Utility fields. After all setup/configuration data has been entered, click on the Download All button. All of the setup data will be downloaded to the Cell Modem Option and stored in flash memory.

## Part 8 – MetriNet Troubleshooting

The following section can be used to correct problems associate with modem communication problems. With the PC utility connected, click on the Tools option on the menu bar and select Com Debug.



**Figure 28 – Troubleshooting - The MetriNet Comm Debug Feature.**

An additional window will appear. Select the Radio Data tab. Click on Reset Radio Modem, then Click on Xmit FTP Data. It takes 6 to 10 seconds for the radio modem to boot up. After that delay, you should see data appear in the Radio Data window. If no data appears, the CPU is not communicating with the Radio Modem. This would indicate some type of hardware failure.

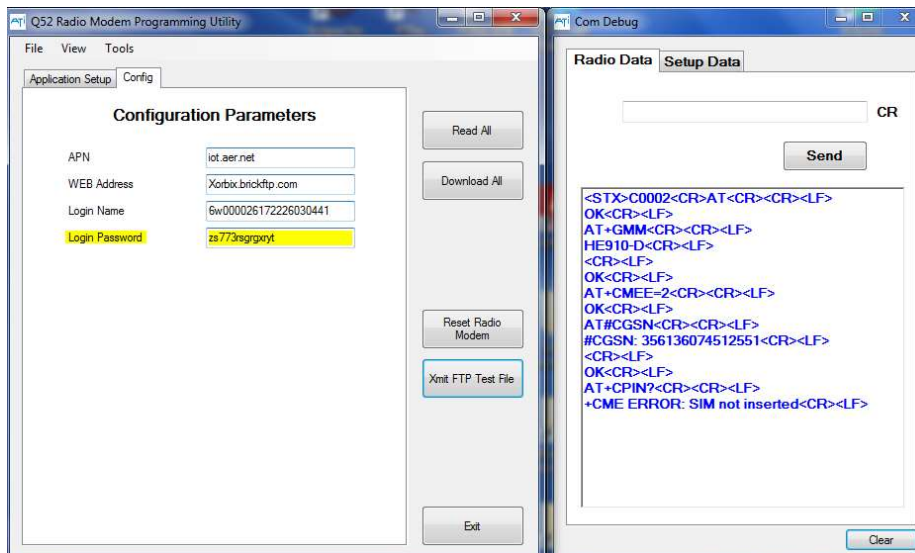

**Figure 29 – Troubleshooting – Radio Modem Reset.**

The above example shows that there is no SIM card installed in the radio modem. When there is no SIM card, data communications to the cell network is not possible. In the example below, the response indicates that an incorrect APN name is entered.

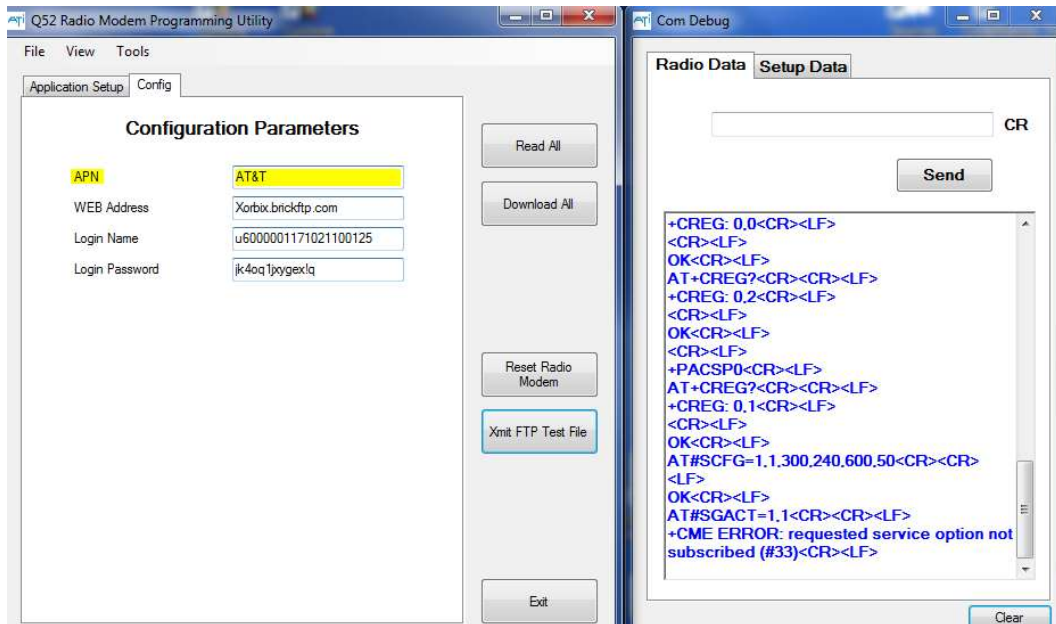

**Figure 30 – Troubleshooting – Radio Modem Reset.**

The next example below shows that the radio modem is not able to register itself with the cell network. When it begins the process, +CREG 0,0 is displayed. Once it registers, +CREG 0,1 is displayed. A value of +CREG 0,2 or +CREG 0,4 indicates some problem communicating with the cell network. In this case the antenna is not connected to the radio modem. Make sure the antenna is screwed onto the connector all the way, and that the antenna cable inside the monitor is plugged onto the radio modem connector labeled M.

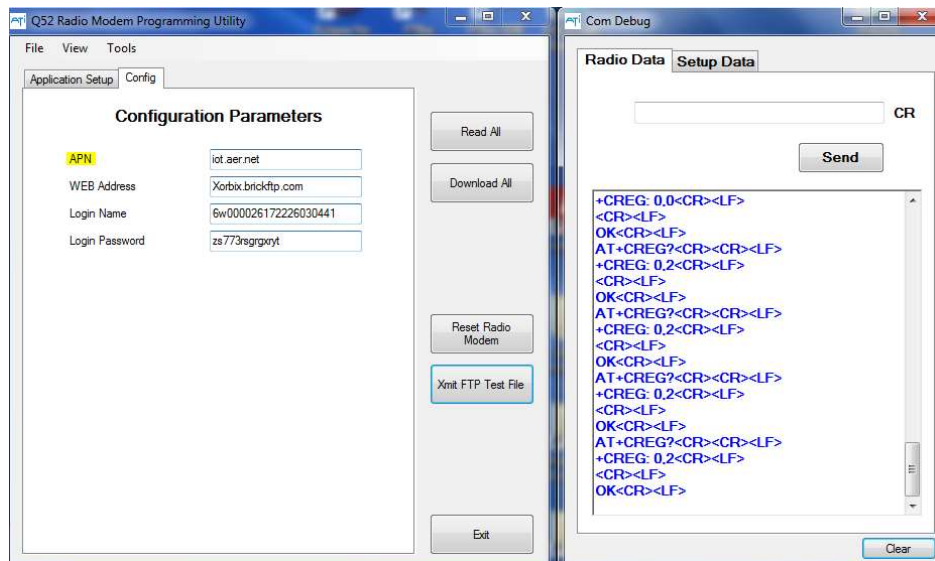

**Figure 31 – Troubleshooting – Modem Registration Issue, CREG.**

The next example shows that the radio modem is getting out to the network, but having a problem logging onto the file server. If the process hangs at this step, check the WEB address, login name and the login password to make sure they are correct. In this example, the sub domain name is missing from the WEB address.

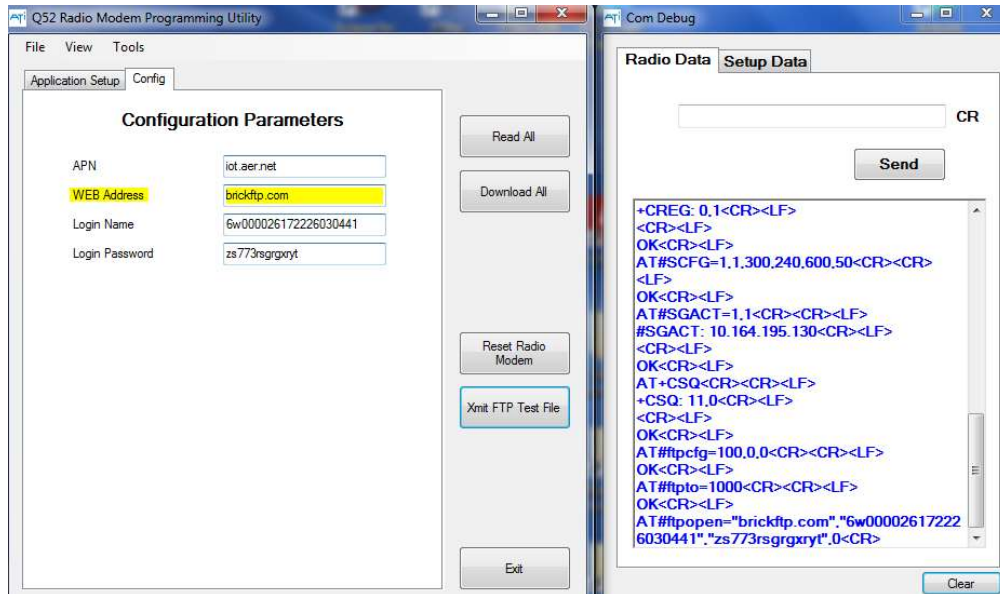

**Figure 32 – Troubleshooting – Cannot Log Into Cloud Server.**

The next example below shows the response from the file server where the WEB address is correct, but the login password is not correct.

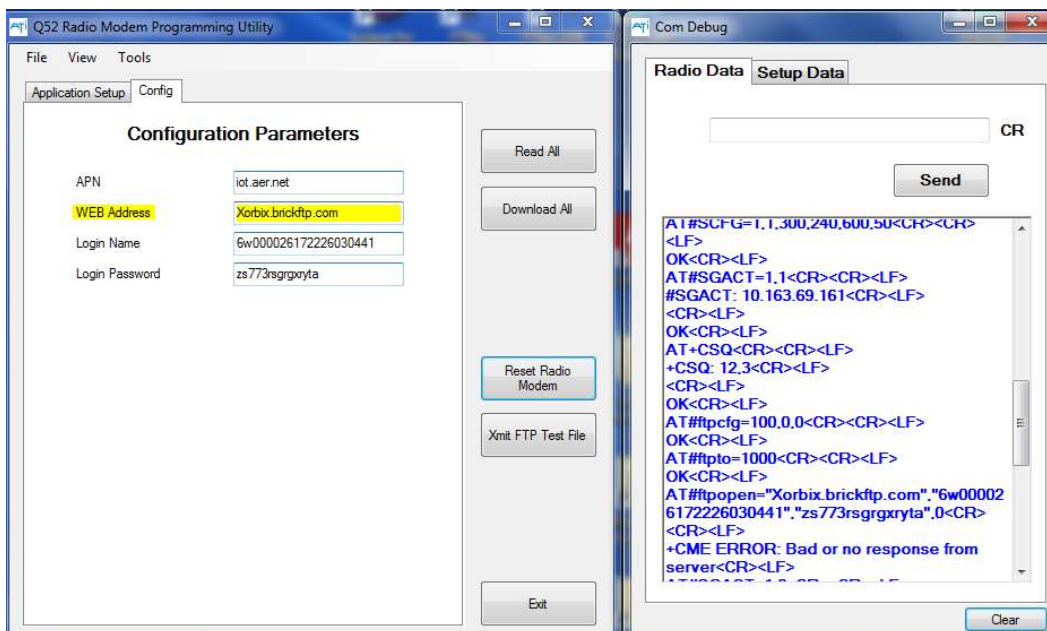

**Figure 33 – Troubleshooting – Possible Password Issue On Cloud Server.**



One bit of data that is displayed is the signal quality as shown below (+CSQ: 11,1). This indicates how good the connection is from the radio modem to the cell tower. A value of 10 or more is good. Less than 10 may still work, but connections may be intermittent, or data transfer may take longer due to the number of retries required to get data uploaded.

The data in this window is absolutely required to aid in diagnosing a communications problem with the radio modem, or between the radio modem and the web site. The data in this window may be copied and pasted into an email message or text file to be sent to tech support.

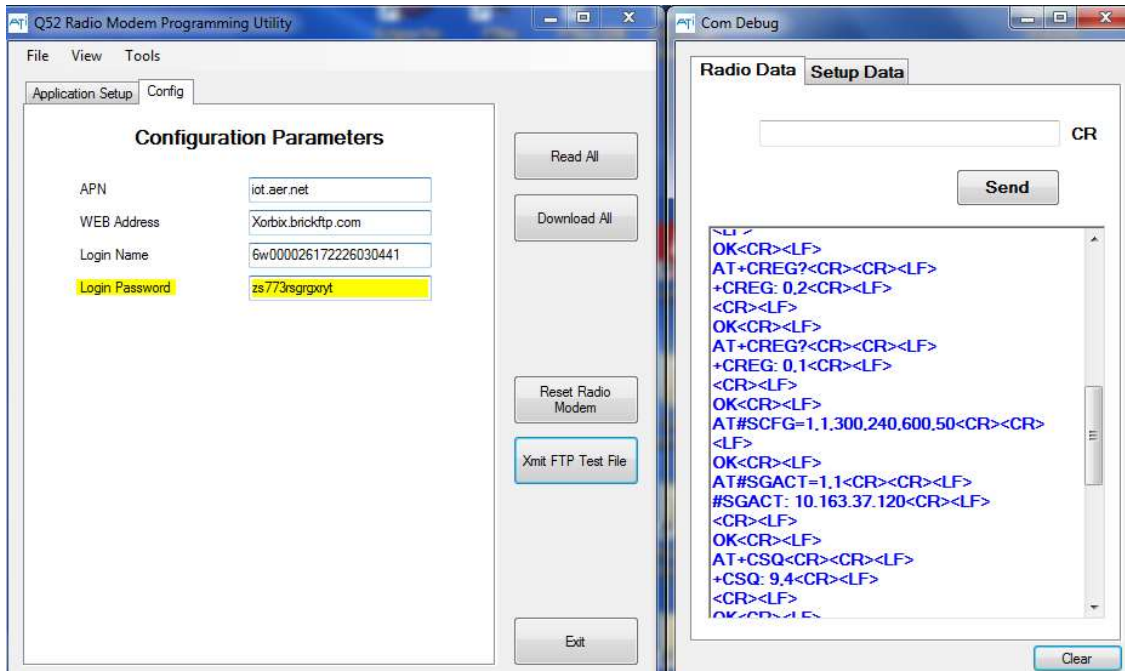

Figure 34 – Troubleshooting – CSQ Data.

# Spare Parts

---

<u>Part No.</u>	<u>Description</u>
-----------------	--------------------

## Electronics

00-1795	MetriNet Controller, 12-24 VDC with SD Card
00-1811	MetriNet Controller, 12V Battery with SD Card
00-1796	MetriNet Controller, 12-24 VDC with SD Card & Modem
00-1812	MetriNet Controller, 12V Battery with SD Card & Modem
00-1885	MetriNet Controller, 12-24 VDC with SD Card & Modbus RTU
00-1891	MetriNet Controller, 12-24 VDC with Ethernet/IP
36-0067	Latching solenoid valve, 12 VDC

## Spare Sensors

00-1733	Free Chlorine M-Node, 0-5.00 ppm
00-1734	Conductivity M-Node, 0-2000 uS
00-1735	pH M-Node, 2-12 pH
00-1736	ORP M-Node, 0-1000 mv.
00-1737	Dissolved Oxygen M-Node, 0-20.00 ppm
00-1738	Dissolved Ozone M-Node, 0-5.00 ppm
00-1739	Turbidity M-Node, 0-40.00
00-1758	Combined Chlorine M-Node, 0-5.00 ppm
00-1780	Total Chlorine M-Node, 0-5.00 ppm
00-1781	Fluoride M-Node, 0.1-10.00 ppm
00-1782	Chlorine Dioxide M-Node, 0-5.00 ppm
00-1783	PAA Sensor, 0-200 PPM
00-1784	Dissolved H2O2 Sensor, 0-20.00 PPM
00-1785	NH4+ Sensor, 0.1-10.00 PPM
00-1786	Nitrite Sensor, 0-2.000 PPM
00-1787	Nitrate Ion Sensor, 0.1-10.00 PPM
00-1802	4E. Cond. Sensor, 0-20.00mS
00-1806	Pressure Sensor

## Flow System

45-0332	Flow chamber only
45-0335	Flow chamber connector ring
03-0490	Flow assembly outlet fitting, no flow regulator, 90° fitting
03-0491	Flow assembly outlet with flow regulator, 90° fitting
05-0130	MetriNet o-ring kit (5 each of flowcell o-ring & M-Node o-ring)
44-0290	Inlet fitting, 1/8" MNPT x 1/4" O.D. tube
44-0269	Outlet fitting, 1/8" MNPT x 1/4" O.D. tube elbow

## Cable Assemblies

31-0202	Node to bus bar cable, 12" (30 cm)
31-0204	Q52 to bus bar cable, 155" (4 m)
31-0208	Q52 power supply cable, 12" (30 cm)
31-0212	Bus bar jumper cable, 18" (46 cm)



**Misc Components**

44-0260	Pg9 Cord Grip (each)
44-0009	Pg11 Cord Grip (each)

# PRODUCT WARRANTY

Analytical Technology, Inc. (Manufacturer) warrants to the Customer that if any part(s) of the Manufacturer's equipment proves to be defective in materials or workmanship within the earlier of 18 months of the date of shipment or 12 months of the date of start-up, such defective parts will be repaired or replaced free of charge. Inspection and repairs to products thought to be defective within the warranty period will be completed at the Manufacturer's facilities in Collegeville, PA. Products on which warranty repairs are required shall be shipped freight prepaid to the Manufacturer. The product(s) will be returned freight prepaid if it is determined by the manufacturer that the part(s) failed due to defective materials or workmanship.

This warranty does not cover consumable items, batteries, or wear items subject to periodic replacement including lamps and fuses.

Gas sensors carry a 12 months from date of shipment warranty and are subject to inspection for evidence of misuse, abuse, alteration, improper storage, or extended exposure to excessive gas concentrations. Should inspection indicate that sensors have failed due to any of the above, the warranty shall not apply.

The Manufacturer assumes no liability for consequential damages of any kind, and the buyer by acceptance of this equipment will assume all liability for the consequences of its use or misuse by the Customer, his employees, or others. A defect within the meaning of this warranty is any part of any piece of a Manufacturer's product which shall, when such part is capable of being renewed, repaired, or replaced, operate to condemn such piece of equipment.

This warranty is in lieu of all other warranties (including without limiting the generality of the foregoing warranties of merchantability and fitness for a particular purpose), guarantees, obligations or liabilities expressed or implied by the Manufacturer or its representatives and by statute or rule of law.

This warranty is void if the Manufacturer's product(s) has been subject to misuse or abuse, or has not been operated or stored in accordance with instructions, or if the serial number has been removed.

Analytical Technology, Inc. makes no other warranty expressed or implied except as stated above.

## WATER QUALITY MONITORS

Dissolved Oxygen  
Free Chlorine  
Combined Chlorine  
Total Chlorine  
Residual Chlorine Dioxide  
Potassium Permanganate  
Dissolved Ozone  
pH/ORP  
Conductivity  
Hydrogen Peroxide  
Peracetic Acid  
Dissolved Sulfide  
Residual Sulfite  
Fluoride  
Dissolved Ammonia  
Turbidity  
Suspended Solids  
Sludge Blanket Level  
**MetriNet** Distribution Monitor

## GAS DETECTION PRODUCTS

NH<sub>3</sub> Ammonia  
CO Carbon Monoxide  
H<sub>2</sub> Hydrogen  
NO Nitric Oxide  
O<sub>2</sub> Oxygen  
CO Cl<sub>2</sub> Phosgene  
Br<sub>2</sub> Bromine  
Cl<sub>2</sub> Chlorine  
ClO<sub>2</sub> Chlorine Dioxide  
F<sub>2</sub> Fluorine  
I<sub>2</sub> Iodine  
H<sub>x</sub> Acid Gases  
C<sub>2</sub>H<sub>4</sub>O Ethylene Oxide  
C<sub>2</sub>H<sub>6</sub>O Alcohol  
O<sub>3</sub> Ozone  
CH<sub>4</sub> Methane  
(Combustible Gas)  
H<sub>2</sub>O<sub>2</sub> Hydrogen Peroxide  
HCl Hydrogen Chloride  
HCN Hydrogen Cyanide  
HF Hydrogen Fluoride  
H<sub>2</sub>S Hydrogen Sulfide  
NO<sub>2</sub> Nitrogen Dioxide  
NO<sub>x</sub> Oxides of Nitrogen  
SO<sub>2</sub> Sulfur Dioxide  
H<sub>2</sub>Se Hydrogen Selenide  
B<sub>2</sub>H<sub>6</sub> Diborane  
GeH<sub>4</sub> Germane  
AsH<sub>3</sub> Arsine  
PH<sub>3</sub> Phosphine  
SiH<sub>4</sub> Silane  
HCHO Formaldehyde  
C<sub>2</sub>H<sub>4</sub>O<sub>3</sub> Peracetic Acid  
DMA Dimethylamine