

SulfideMonitor

Model Q46S/81



Sulfides can be found naturally in well water and can build up in wastewater collection systems due to anaerobic conditions frequently found there. In addition, sulfides are used in mercury removal processes and are frequently found in tanning wastes. In drinking water systems, sulfides cause taste and odor problems. In wastewater systems, sulfides cause damage to concrete structures in collection systems and contribute to odor problems in treatment facilities.

Measurement of dissolved sulfide concentrations has been done primarily by the use of analyzers employing ion selective electrodes (ISE) for sensing. While providing adequate sensitivity, ISE based systems require frequent zero and span adjustments to maintain measurement accuracy. Because of this, most ISE based monitoring systems are relatively expensive and require frequent service.

ATI's Model Q46S/81 Dissolved Sulfide Monitor provides an improved method for measuring sulfides in solution.

Call [800.959.0299](tel:800.959.0299) to speak with a sales representative or visit us on the web at www.analyticaltechnology.com



FEATURES

Sulfide Measurement. Sulfide ion is measured selectively by conversion to hydrogen sulfide.

Gas Phase Sensing. Measurement is made without contact between sample and sensor, eliminating the potential for sensor fouling.

Chemistry Module Power Options. Power options include 115 or 230 VAC, 50/60 Hz.

Three Control Relays. Relays are programmable for setpoint, deadband, and time delay.

Sample Line Cleaning. Internal sequencing and relay system for automated sample line cleaning.

Digital Communication. Communication options for Profibus-DP, Modbus-RTU, or Ethernet-IP.



Q46S/81 Sulfide Monitor

A *Gas-Phase* approach to Sulfide Measurement

THEORY OF OPERATION

Because measuring sulfides in a solution using an ISE is relatively difficult, the Q46S/81 Monitor takes a different approach to the measurement, employing a unique gas-phase method to continuously monitor sulfide without contact between the sensor and the water sample. In operation, a small amount of sample is pumped into the system and mixed with acid. Under acidic conditions, the sulfide ion is converted to hydrogen sulfide gas as follows:

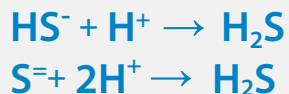

The mixed sample flows into a special chamber where the hydrogen sulfide is stripped from the sample. A gas conditioning module prepares the gas sample for measurement prior to contact with a special H₂S gas sensor designed for the system. Sensor signals are amplified and displayed on a large-format, backlit LCD display in the Q46S electronics unit.

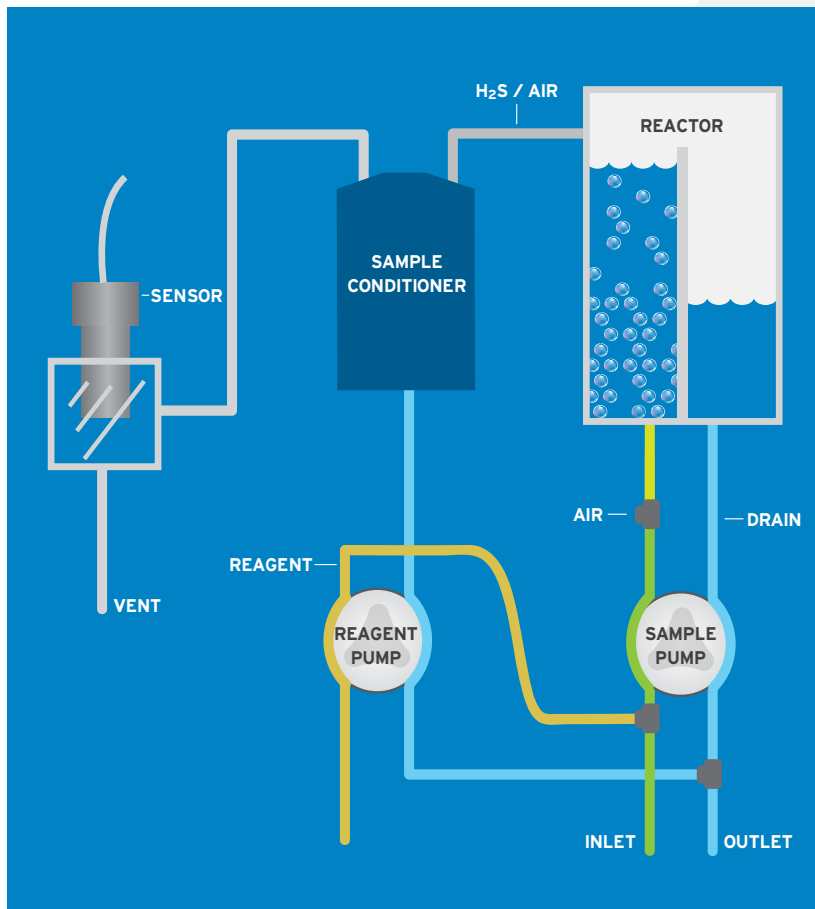

INSTALLATION

A sample inlet overflow block is provided on the bottom of the chemistry module. Sample is connected using ¼" I.D. flexible tubing, with a recommended flow rate of 5-20 gallons per hour. While the monitor uses only a small fraction of this sample, the higher flow keeps sample delivery times to a minimum. Excess sample simply overflows to a gravity drain chamber requiring a ½" I.D. flexible tube.

Sulfide monitoring systems are extremely easy to operate and maintain, with acid usage of one gallon every 25 days at standard flow rates. Sample and acid are pumped using long life peristaltic pump tubing that requires replacement approximately every 6 months. Pump heads are designed for easy tube changes, requiring about 10 minutes to replace both pump tubes. The sulfide sensor requires no maintenance other than an occasional visual inspection to insure that no deposits have collected due to airborne particulates.

The gas stripping technique for monitoring sulfide in solution provides an extremely sensitive on-line monitor. Measurements down to low parts-per-billion can be done easily, and zero and span stability inherent in the sensor allow for monthly calibration cycles.

High Sensitivity Sulfide Monitoring

APPLICATIONS

Well Water: In some areas of the country, dissolved H₂S is found in ground water, making it unfit for use without treatment. The sulfides can be removed using air stripping systems or chemical oxidation. The Q46S/81 provides a reliable way to monitor both the level of sulfides in the raw water and the concentration remaining after treatment.

Wastewater: Sulfides in wastewater collection systems can result in severe damage to concrete structures in the collection system. While not necessarily present continuously, chemical oxidation with hydrogen peroxide or biological nitrate treatment systems can be activated during periods when sulfides are detected.

Tanning Waste: The production of leather produces wastewater with very high sulfide levels. While the monitor cannot measure the high levels found in raw waste, it can effectively measure low levels after treatment to remove these sulfides.

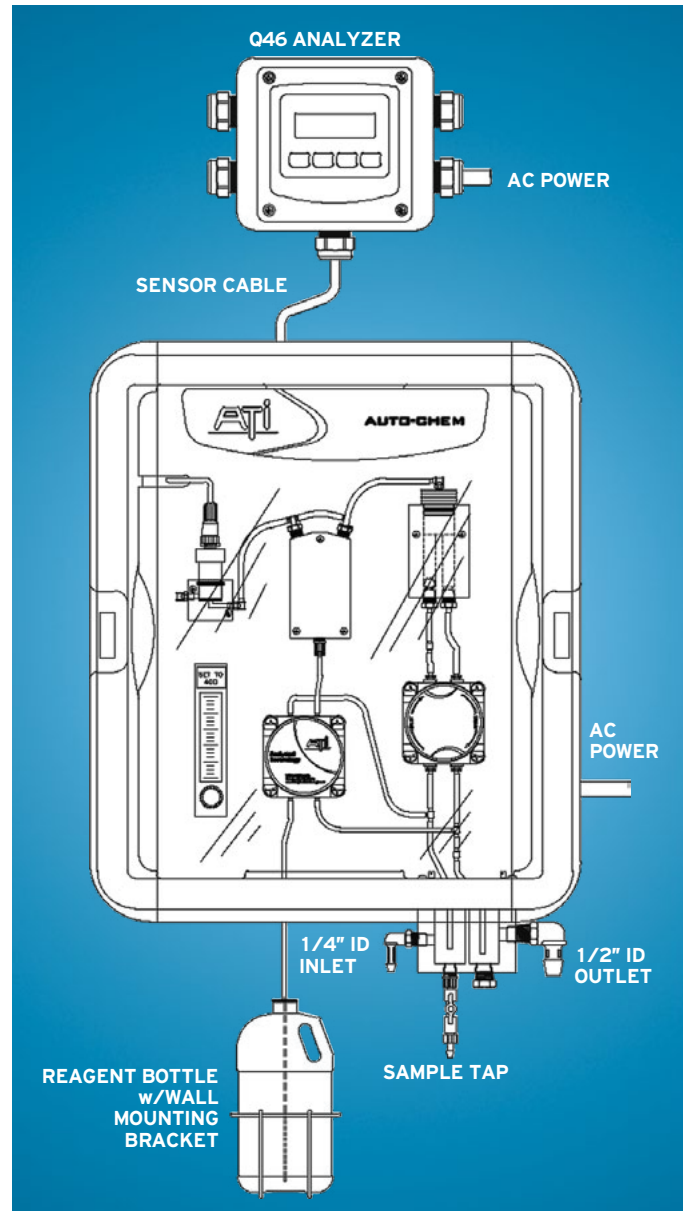

Q46S/81 SPECIFICATIONS

ELECTRONIC MONITOR

Display Range	0-2.000 or 0-20.00 PPM
Accuracy	+/- 0.002 PPM
Repeatability	+/- 0.002 PPM
Linearity	0.5% of F.S.
Zero Drift	< 0.005 PPM per month
Power	100-240 VAC +/- 10%, 50/60 Hz
Analog Outputs	Two isolated 4-20 mA, 500 Ω load max.
Relays	Three SPDT, 6A @250 VAC, 5A @24 VDC
Display	4-digit, 0.75" numeric LCD with 12-digit second line, LED back light.
Enclosure	NEMA 4X (IP-66) Polycarbonate, V-0 flammability
Operating Temperature	-20 to 60°C (-4 to 140°F)
Weight	2.5 lbs. (1.1 Kg)

CHEMISTRY MODULE

Sulfide Sensor	Membraned H ₂ S Gas Sensor
Sensor Cable	25 ft standard, 100 ft max.
Response Time	95% in 3 minutes
Sample Pump	Internal tubing pump, 7 cc/min
Acid Pump	Internal tubing pump, 0.1 cc/min
Air Supply	Diaphragm air pump with precision flow control
Air Stripping Chamber	Cast Acrylic
Inlet Sample Flow Rate	5-20 GPH at inlet overflow assembly
Sample Inlet	1/4" I.D. Hose Barb
Sample Drain	1/2" I.D. Hose Barb
Power	115 or 230 VAC (customer specified)
Operating Temp.	2 to 50°C
Enclosure	Kydex with acrylic cover, V-0 flammability
Weight	15lbs (6.8 Kg)

ORDERING INFORMATION

Model Q46S/81-A-B Sulfide Monitor

Suffix A - Power

- 1 - 115 VAC, 50/60 Hz
- 2 - 230 VAC, 50/60 Hz

Suffix B - Digital Output

- 1 - None
- 2 - Profibus-DP
- 3 - Modbus-RTU
- 4 - Ethernet-IP

ACCESSORIES

- 31-0038** 7-c Sensor interconnect cable, 100 ft max.
- 05-0094** Panel Mount Bracket Kit
- 47-0005** 2" U-bolt, 304SS

Your Source for Water Quality Monitors!

ATI supplies a variety of on-line monitoring instruments for municipal and industrial water monitoring. Contact us if your measurement needs include:

- Residual Chlorine
- Dissolved Oxygen
- pH/ORP
- Conductivity
- Turbidity
- Dissolved Ozone



Visit Us on the Web: www.analyticaltechnology.com

B / Q46S/81 / (8/13)

Analytical Technology, Inc.

6 Iron Bridge Drive
 Collegeville, PA 19462
Phone 610.917.0991
Toll-Free 800.959.0299
Fax 610.917.0992
Email sales@analyticaltechnology.com

Analytical Technology

Unit 1 & 2 - Gatehead Business Park
 Delph New Road, Delph
 Saddleworth OL3 5DE
Phone 01457 873 318
Fax 01457 874 468
Email sales@atiuk.com

Represented by:

