



O & M Manual



Model Q46C2C 2-Electrode Concentration Monitor

Home Office

Analytical Technology, Inc.
6 Iron Bridge Drive
Collegeville, PA 19426
Phone: 800-959-0299
610-917-0991
Fax: 610-917-0992
Email: sales@analyticaltechnology.com

European Office

ATI (UK) Limited
Unit 1 & 2 Gatehead Business Park
Delph New Road, Delph
Saddleworth OL3 5DE
Phone: +44 (0)1457-873-318
Fax: + 44 (0)1457-874-468
Email: sales@atiuk.com

Table of Contents

TABLE OF FIGURES	3	PART 6 - CONTROL	34
PART 1 - INTRODUCTION.....	4	PART - 7 DIAGNOSTICS MENU [DIAG].....	38
1.1 General	4	PART 8 – CALIBRATION	41
1.2 Features.....	5	8.1 Overview and Methods.....	41
1.3 Q46C2C System Specifications	5	8.11 1-Point Calibration Explained	41
1.4 Q46C2C Performance Specs.	7	8.12 Cell Constant Calibration Explained ..	41
PART 2 – ANALYZER MOUNTING	8	41
2.1 General	8	8.13 Zero Calibration Explained	41
2.2 Wall or Pipe Mount	9	8.2 Performing a 1-Point Calibration	42
2.3 Panel Mount.....	11	8.3 Performing a Cell Constant Calibration ..	43
PART 3 – SENSOR MECHANICALS	12	43
3.1 General	12	8.4 Performing a Sensor Zero Calibration	44
PART 4 – ELECTRICAL INSTALLATION	14	8.5 Temperature Calibration.....	44
4.1 General	14	8.6 TC Factor Calibration	45
4.2 Power Connection	14	PART 9 – PID CONTROLLER DETAILS.....	46
4.3 Relay Connection	16	9.1 PID Description	46
4.4 Optional Output or Relay Connections	17	9.2 PID Algorithm	46
4.5 Sensor Wiring	18	9.3 Classical PID Tuning	48
4.6 Direct Sensor Connection.....	19	9.4 Manual PID Override Control	48
4.7 Junction Box Connection	20	9.5 Common PID Pitfalls	48
4.8 In-Line Sensor Connection	21	PART 10 – SYSTEM MAINTENANCE.....	50
4.9 OEM Sensor Connection	22	10.1 System Checks.....	50
4.10 Sanitary Sensor Connection	23	10.2 Instrument Checks.....	50
PART 5 – CONFIGURATION	24	10.4 Cleaning the Sensor	52
5.1 User Interface	24	10.5 Sensor Testing.....	53
5.11 Keys	25	SPARE PARTS	54
5.12 Display	25		
5.2 Software.....	26		
5.21 Software Navigation	27		
5.22 Measure Menu [MEASURE]	29		
5.23 Calibration Menu [CAL]	29		
5.24 Configuration Menu [CONFIG].....	30		

Table of Figures

FIGURE 1 - ENCLOSURE DIMENSIONS, AC POWERED UNITS	8
FIGURE 2 - WALL OR PIPE MOUNT BRACKET.....	9
FIGURE 3 - WALL MOUNTING DIMENSIONS.....	10
FIGURE 4 - PIPE MOUNTING DIAGRAM	10
FIGURE 5 - PANEL CUTOUT AND MOUNTING.....	11
FIGURE 6 – INSERTION/SUBMERSIBLE STYLE SENSOR DIMENSIONS.....	12
FIGURE 7 - SANITARY STYLE PROBE DIMENSIONS.....	13
FIGURE 8 - Q46 CONNECTION LAYOUT.....	15
FIGURE 9 - RELAY CONNECTIONS.....	16
FIGURE 10 - OPTIONAL RELAY BOARD WIRING	17
FIGURE 11 - OPTIONAL ANALOG OUTPUT WIRING	17
FIGURE 12 - CABLE DESCRIPTION, MODEL Q25C2	18
FIGURE 13 - SENSOR CABLE PREPARATION.....	19
FIGURE 14 - JUNCTION BOX INTERCONNECT WIRING.....	20
FIGURE 15 - IN-LINE SENSOR CONNECTION.....	21
FIGURE 16 - OEM SENSOR CONNECTIONS.....	22
FIGURE 17 - SANITARY SENSOR WIRING.....	23
FIGURE 18 - USER INTERFACE	24
FIGURE 19 - SOFTWARE MAP.....	28
FIGURE 20 - CONTROL RELAY EXAMPLE.....	36
FIGURE 21 - ALARM RELAY EXAMPLE	37
FIGURE 22 - NAACL REFERENCE SOLUTION FOR CALIBRATION.....	42
FIGURE 23 - Q46 ISA (IDEAL) EQUATION.....	46
FIGURE 24 - PT1000 RESISTANCE TABLE.....	53

Part 1 - Introduction

1.1 General

The Model Q46C2C Concentration monitor/analyzer provides an extremely versatile measurement system for monitoring and control of percent concentration of a chemical dissolved in a solution. The monitor can be programmed to display TDS (Total Dissolved Solids) or percent concentration. User data is required for the customized concentration table to be created.

Monitors are available in two electronic versions, a universal AC powered monitor for operation from 90-260 VAC and a 12-24 VDC unit. Both versions provide two 4-20 mA analog outputs and 3 SPDT relays. One analog output may be configured for PID control and one of the relays may be configured to provide a remote trouble indication.

In all configurations, the Q46C2C displays conductivity, sensor temperature, TDS/Concentration, and output loop current on the secondary line of the custom display. The instrument is used with the Q25C2 sensors or other compatible 2-electrode sensors. Q25C2 sensors are available with 0.5K cell constant and in submersible, in-line, or 1 1/2" sanitary versions.

NOTE: When the Q46C2C is used in Concentration or TDS mode, a 0.5K cell constant sensor must be used.



WARNING: Not following operating instructions may impair safety.

1.2 Features

- Power options for either AC or low voltage DC operation.
- Two analog outputs on the relay version may be configured to track concentration and temperature. Both analog outputs can be individually programmed to fail to specific values. A third 4-20 mA output is available as an option.
- Three 6 amp SPDT relay outputs and two analog 4-20 mA outputs are standard. Software settings for relay control include setpoint, deadband, phase, delay, and failsafe. An optional 3-relay card, for 0-30 V signals, is available to bring the total to 6 relays.
- Digital communication option for Profibus-DP, Modbus-RTU, and Ethernet-IP. See Q46 Digital Communications Manual for Specifications.
- Output Hold, Output Simulate, Output Alarm, and Output Delay Functions. All forced changes in output condition include bumpless transfer to provide gradual return to on-line signal levels and to avoid system control shocks on both analog outputs.
- Selectable PID controller on main analog output. PID includes manual operation feature, and diagnostic “stuck-controller” timer feature for relay notification of control problems.
- Large, high contrast, custom LCD display with LED back light provides excellent readability in any light conditions. The second line of display utilizes 5x7 dot matrix characters for clear message display.
- Diagnostic messages provide a clear description of any problem with no confusing error codes to look up. Messages are also included for diagnosing calibration problems.
- Quick and easy one-point calibration method and sensor zero-cal. To provide high accuracy, all calibration methods include stability monitors that check temperature and main parameter stability before accepting data.
- Selectable Pt1000 or Pt100 temperature inputs. Systems can also be hard-configured for three-wire elements. Temperature element can be user calibrated.
- Security lock feature to prevent unauthorized tampering with transmitter settings. All settings can be viewed while locked, but they cannot be changed.

1.3 Q46C2C System Specifications

Displayed Parameter	Main input, User Configurable Table Sensor temperature, -10.0 to 210.0 °C (23 to 410 °F) Conductivity, 0 to 200.0 uS Loop current, 4.00 to 20.00 mA Cell Constant Model number and software version PID Controller Status Timer Status
----------------------------	---

Power	90 - 260 VAC, 50-60 Hz, 10 VA max. or 12-24 VDC, 500 mA max.
Analog Outputs	Two 4-20 mA outputs. Output one programmable for concentration or PID. Output 2 programmable for concentration or Temperature. Max load 500 Ohms for each output. Outputs ground isolated and isolated from each other. An additional 3 rd analog option is available.
Relays, Electromechanical	Three SPDT, 6 amp @ 250 VAC, 5 amp @ 24 VDC contacts. Software selection for setpoint, phase, delay, deadband, hi-lo alarm, and failsafe. A-B indicators on main LCD, and C indicator on lower display. Three additional low power relays optional.
Enclosure	NEMA 4X, polycarbonate, stainless steel hardware, weatherproof and corrosion resistant,
Conduit Openings	Five ½" NPT openings, Adapter can be removed to provide a 1" NPT opening in the bottom of the enclosure. Gland seals provided but not installed.
Mounting Options	Wall or pipe mount bracket standard. Bracket suitable for either 1.5" or 2" I.D. U-Bolts for pipe mounting. Panel mount bracket optional.
Weight	2 lb. (0.9 kg)
Display	0.75" (19.1 mm) high 4-digit main display with sign 12-digit secondary display, 0.3" (7.6 mm) 5x7 dot matrix. Integral LED back-light for visibility in the dark.
Ambient Temperature	Service, -20 to 60 °C (-4 to 140 °F) Storage, -30 to 70 °C (-22 to 158 °F)
Ambient Humidity	0 to 95%, indoor/outdoor use, non-condensing to rated ambient temperature range
Altitude	2000 m (6562 Ft.)
Electrical Certification	Ordinary Location, cCSAus (CSA and UL standards- both CSA approved), pollution degree 2, installation category 2
EMI/RFI Influence	Designed to EN 61326-1, CE Certified
Output Isolation	600 V galvanic isolation
Filter	Adjustable 0-9.9 minutes additional damping to 90% step input
Temperature Input	Selectable Pt1000 or Pt100 RTD

Q25C2 Conductivity sensors

Cell Constant	0.5K
Measuring Range	User Defined Table (0-200 uS)
Temperature Element	Pt1000 RTD with automatic compensation
Wetted Materials	Titanium, PEEK, 316 Stainless steel
Temperature Compensation	Pt1000 RTD
Sensor Cable	6 Conductor plus 2 shields,
Temperature Range	-10° to +125° C
Pressure Range	0-100 PSIG
Maximum Flow Rate	10 feet (3 meters) per second

1.4 Q46C2C Performance Specs.

Accuracy	0.1% of span or better
Repeatability	0.1% of span or better
Sensitivity	0.05% of span
Stability	0.05% of span per 24 hours, non-cumulative
Warm-up Time	7 seconds to rated performance
Supply Voltage Effects	± 0.05% span
Instrument Response Time	2 seconds to 90% of step input at lowest setting
Temperature Drift	Span or zero, 0.03% of span/°C
Max. Sensor-Instrument Distance	60 ft. (18.2 meters)
Sensor Types	Model Q25C2 - 4 wire input or equal



Equipment bearing this marking may not be discarded by traditional methods in the European community after August 12 2005 per EU Directive 2002/96/EC. End users must return old equipment to the manufacturer for proper disposal.



Part 2 – Analyzer Mounting

2.1 General

All Q46 Series instruments offer maximum mounting flexibility. A bracket is included with each unit that allows mounting to walls or pipes. In all cases, choose a location that is readily accessible for calibrations. Also consider that it may be necessary to utilize a location where solutions can be used during the calibration process. To take full advantage of the high contrast display, mount the instrument in a location where the display can be viewed from various angles and long distances.

Locate the instrument in close proximity to the point of sensor installation - this will allow easy access during calibration. The standard cable length of the conductivity sensor is 20 feet. For sensor cables longer than 20 feet, use the optional junction box (07-0100) and sensor interconnect cable (31-0057).

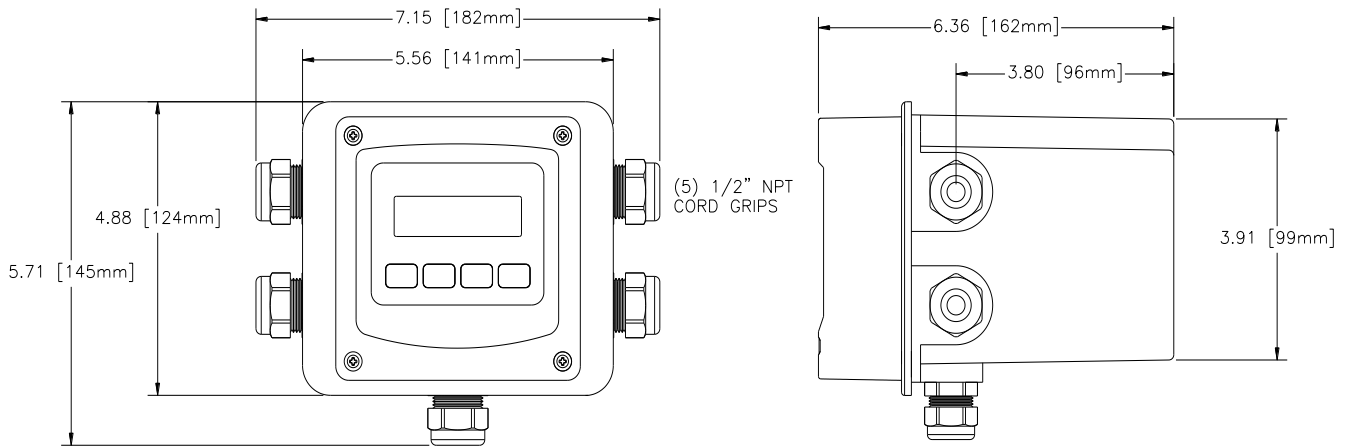

Figure 1 - Enclosure Dimensions, AC Powered Units

2.2 Wall or Pipe Mount

A PVC mounting bracket with attachment screws is supplied with each transmitter (see **Figure 2** for dimensions). The multi-purpose bracket is attached to the rear of the enclosure using the four flat head screws. The instrument is then attached to the wall using the four outer mounting holes in the bracket. These holes are slotted to accommodate two sizes of u-bolt that may be used to pipe mount the unit. Slots will accommodate u-bolts designed for 1½" or 2" pipe. The actual center to center dimensions for the u-bolts are shown in the drawing. Note that these slots are for u-bolts with ¼-20 threads. The 1½" pipe u-bolt (2" I.D. clearance) is available from ATI in type 304 stainless steel (47-0005).

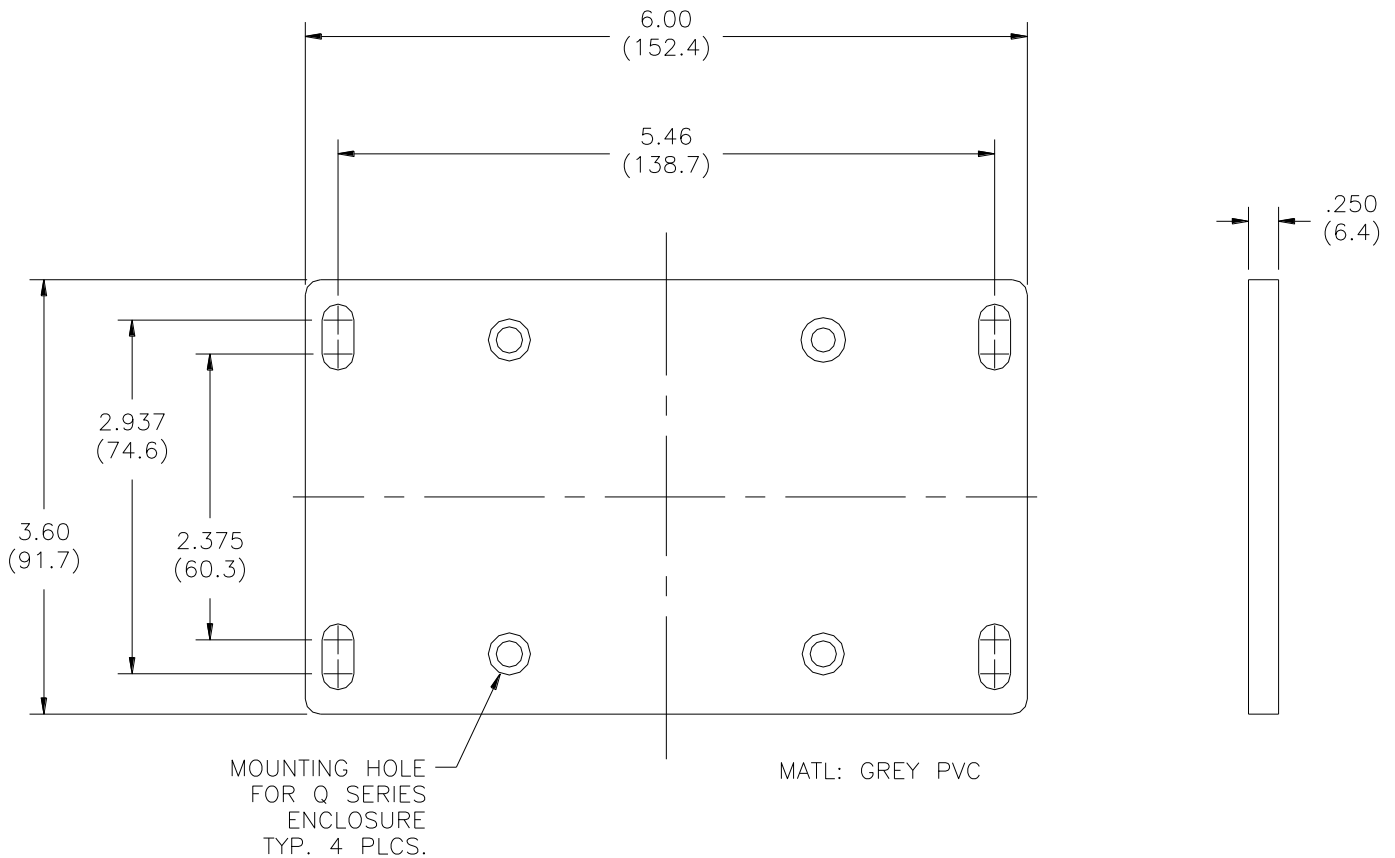

Figure 2 - Wall or Pipe Mount Bracket

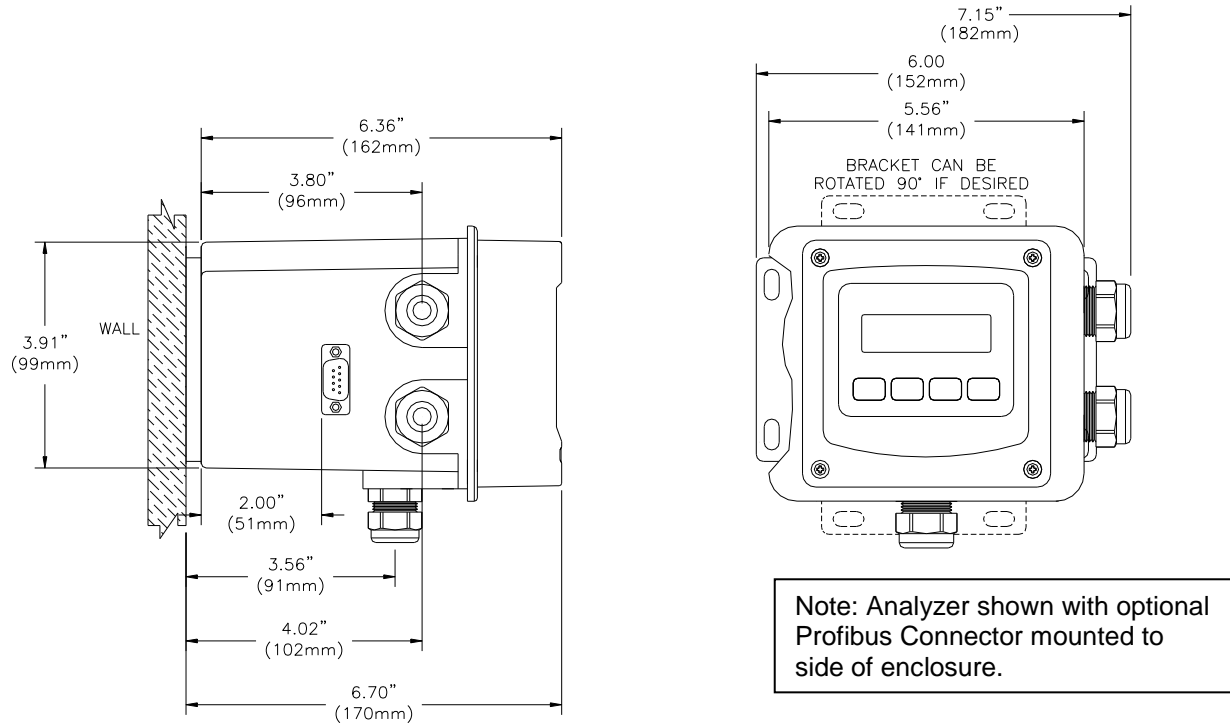

Figure 3 - Wall Mounting Dimensions

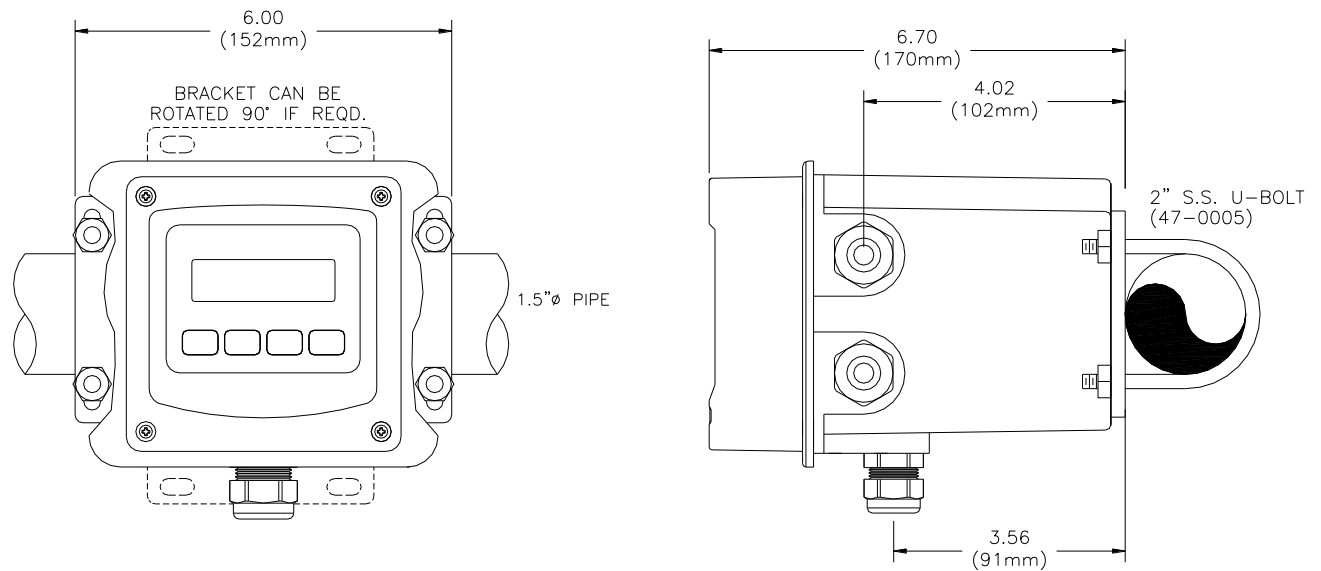

Figure 4 - Pipe Mounting Diagram

2.3 Panel Mount

Panel mounting of an AC powered monitor uses the panel mounting flange molded into the rear section of the enclosure. **Figure 5** provides dimensions for the panel cutout required for mounting.

The panel mounting bracket kit must be ordered separately (part number 05-0094). This kit contains a metal retainer bracket that attaches to the rear of the enclosure, 4 screws for attachment of this bracket, and a sealing gasket to insure that the panel mounted monitor provides a water tight seal when mounted to a panel.

The sealing gasket must first be attached to the enclosure. The gasket contains an adhesive on one side so that it remains in place on the enclosure. Remove the protective paper from the adhesive side of the gasket and slide the gasket over the back of the enclosure so that the adhesive side lines up with the back of the enclosure flange. Once in place, you can proceed to mount the monitor in the panel.

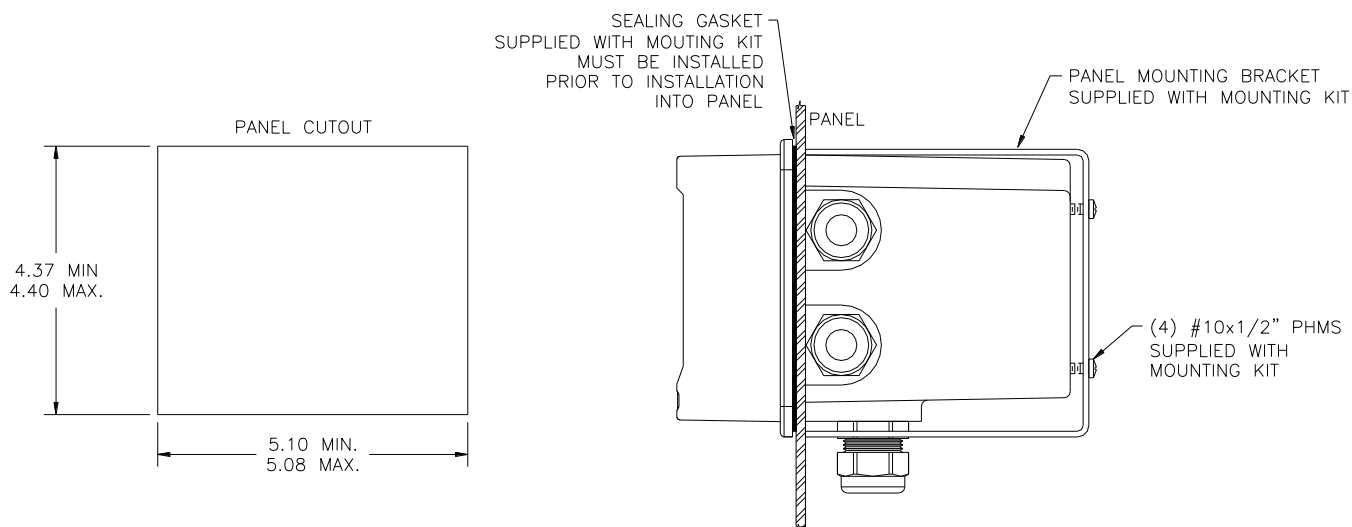

Figure 5 - Panel Cutout and Mounting

Part 3 – Sensor Mechanicals

3.1 General

The Q25C2 Conductivity Sensors are designed for industrial and municipal process applications. Mounting options include flow-through, submersion, or sanitary mount depending on the type of sensor purchased. The sensor-to-analyzer distance must not exceed 60 feet (18.2 meters).

Calibrate the sensor before placing it into the process. See **Part 8** of this manual for detailed calibration instructions.

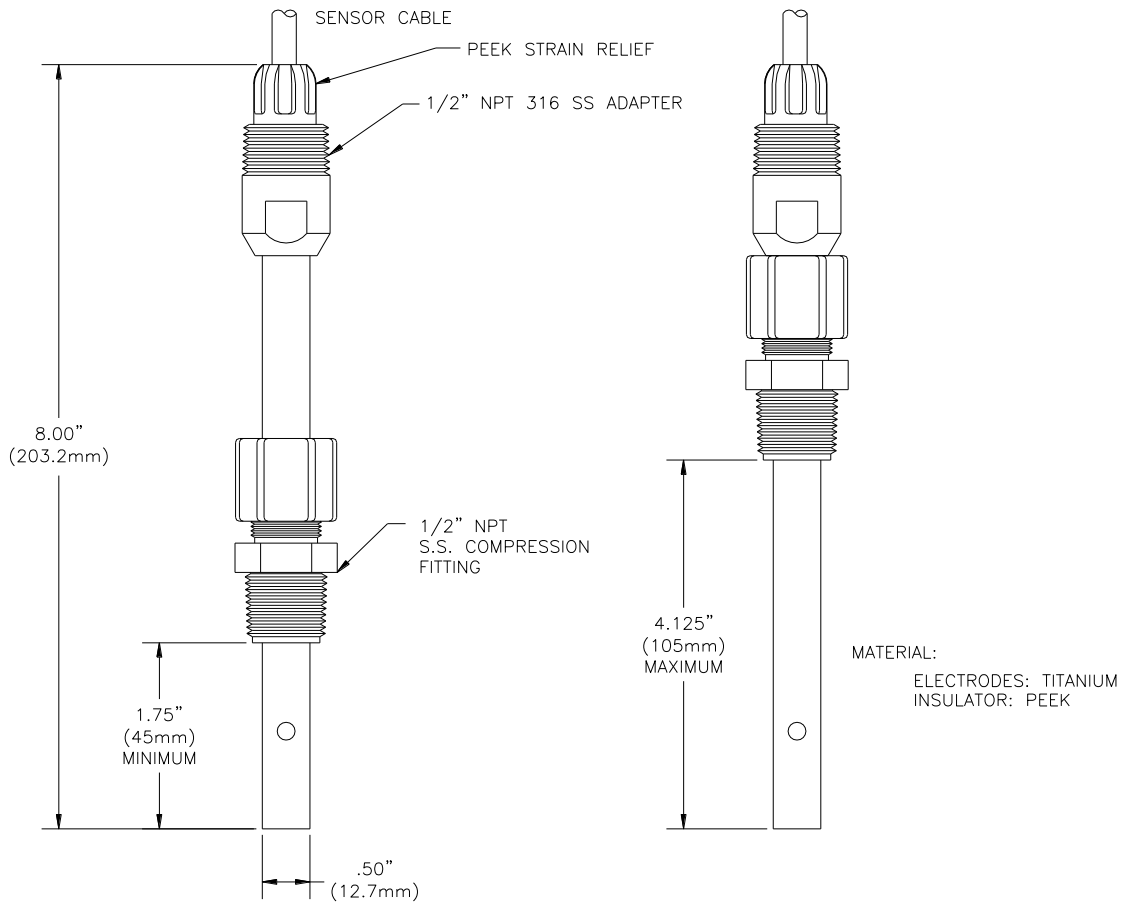

Figure 6 – Insertion/Submersible Style Sensor Dimensions

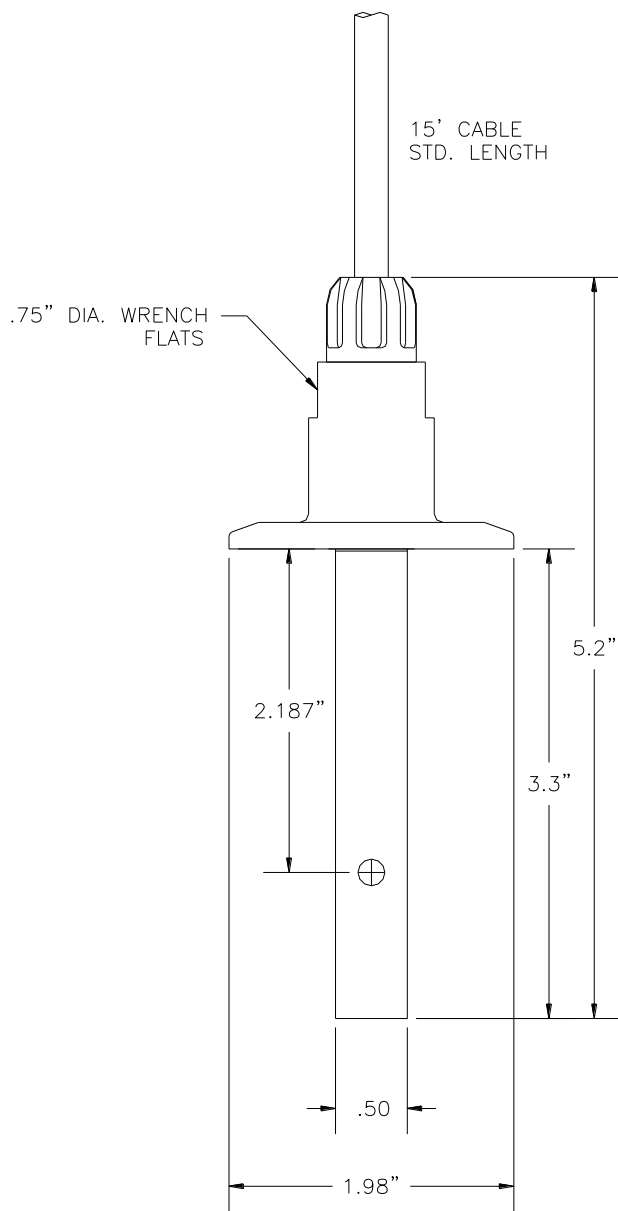

Figure 7 - Sanitary Style Probe Dimensions

Part 4 – Electrical Installation

4.1 General

The Q46 is powered in one of two ways, depending on the version purchased. The 12-24 VDC powered analyzer requires a customer supplied DC power supply. The 90-260 VAC version requires line power. Please verify the type of unit before connecting any power.



WARNING: Do not connect AC line power to the DC version. Severe damage will result.

Important Notes:

1. Use wiring practices that conform to all national, state and local electrical codes. For proper safety as well as stable measuring performance, it is important that the earth ground connection be made to a solid ground point from TB7. The AC power supply contains a single 630mA slo-blo fuse (Wickmann/Littlefuse #372-0630). The fuse **F1** is located adjacent to **TB7** and is easily replaceable.
2. Do NOT run sensor cables or instrument 4-20 mA output wiring in the same conduit that contains AC power wiring. AC power wiring should be run in a dedicated conduit to prevent electrical noise from coupling with the instrumentation signals.
3. This analyzer must be installed by specifically trained personnel in accordance with relevant local codes and instructions contained in this operating manual. Observe the analyzer's technical specifications and input ratings. Proper electrical disconnection means must be provided prior to the electrical power connected to this instrument, such as a circuit breaker - rated 250 VAC, 2 A minimum. If one line of the line power mains is not neutral, use a double-pole mains switch to disconnect the analyzer.
4. Repeated problems with lightning strikes damaging sensitive instrumentation are often attributed to poorly bonded earth grounds in the instrument power source. The protection schemes incorporated into this analyzer cannot operate to maximum efficiency unless the ground connection is at its' absolute lowest impedance.

There is no standard ground resistance universally recognized. Many agencies recommend a ground resistance value of 5 ohms or less. The NEC recommends an impedance to ground of less than 25 ohms, and less than 5 ohms where sensitive equipment is installed. Power sources feeding sensitive instruments like the Q46 should have the lowest possible impedance to ground.

4.2 Power Connection

Verify the AC power supply requirement before installing. Also verify that power is fully disconnected before attempting to wire.

Q46 systems are supplied with 5 cable gland fittings for sealing cable entries.

Connect HOT, NEUTRAL, and GROUND to the matching designations on terminal strip **TB7**.

WARNING

Disconnect line power voltage BEFORE connecting line power wires to Terminal TB7 of the power supply. The power supply accepts only standard three-wire single phase power. AC power supplies are configured for 90-260 VAC operation at the factory at time of order, and the power supply is labeled as such. Do NOT connect voltages other than the labeled requirement to the input.

The two analog outputs for the standard system are present at terminal TB1. The loop-load limitation in this configuration is 500 Ohms maximum for each output. Also note that these two outputs are completely isolated from each other to insure that ground loops do not result from the connection of both outputs to the same device such as a PLC or DCS.

A ribbon cable connects the power supply assembly with the microprocessor assembly located in the front section of the enclosure. This cable may be unplugged from the front section of the monitor if service is needed, but should normally be left in place during installation.

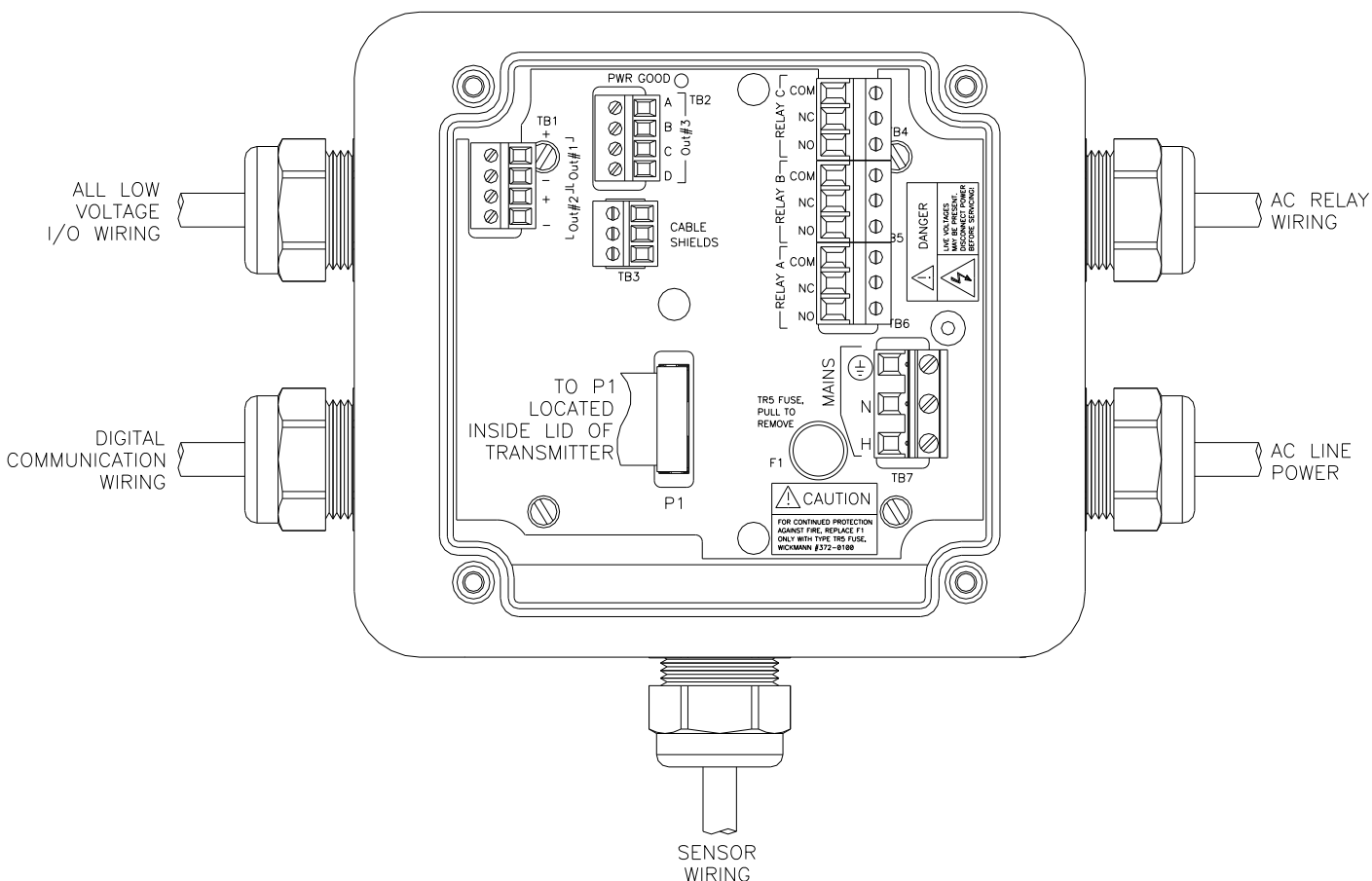

Figure 8 - Q46 Connection Layout

4.3 Relay Connection

Three SPDT relays are provided on the power supply board. None of the relay contacts are powered. The user must supply the proper power to the contacts. For applications that require the same switched operating voltage as the Q46 (115 or 230 V), power may be jumpered from the power input terminals at **TB7**. Relay wiring is connected at **TB4**, **TB5**, and **TB6** as shown below. Note that the relay contact markings are shown in the NORMAL mode. Programming a relay for “Failsafe” operation reverses the NO and NC positions as shown in diagram below.

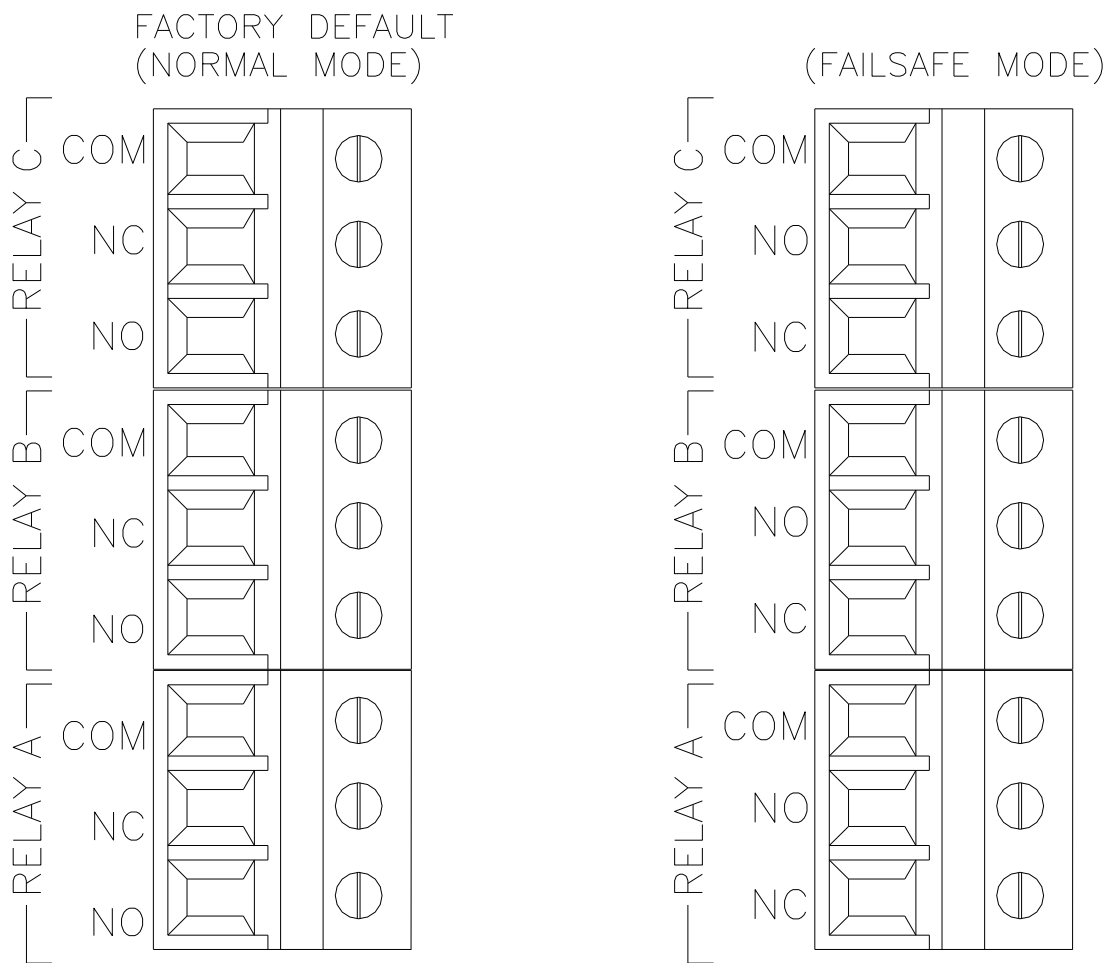

Figure 9 - Relay Connections

4.4 Optional Output or Relay Connections

TB2, is used to connect to the optional 3-relay card (**Figure 10**) **OR** the optional third analog output, Out#3, (**Figure 11**). The Q46 can be configured for only one of these optional features, and the hardware for either option must be factory installed.

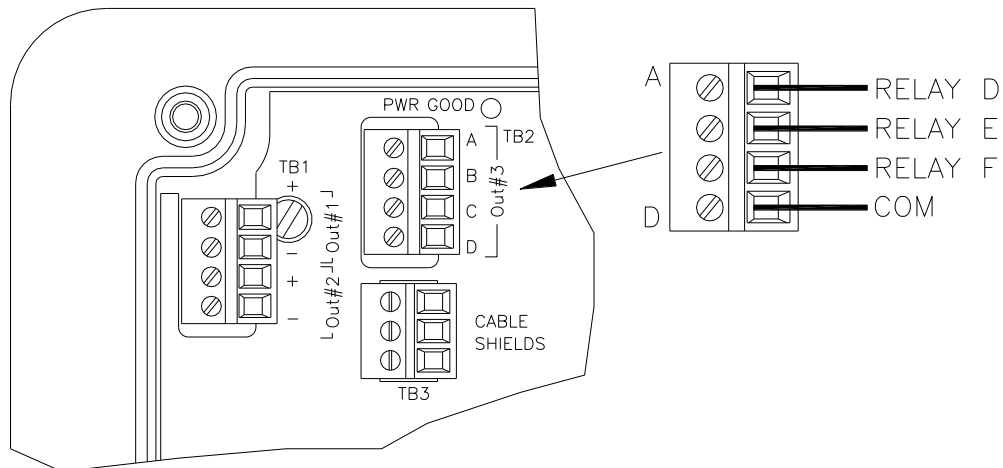

Figure 10 - Optional Relay Board Wiring

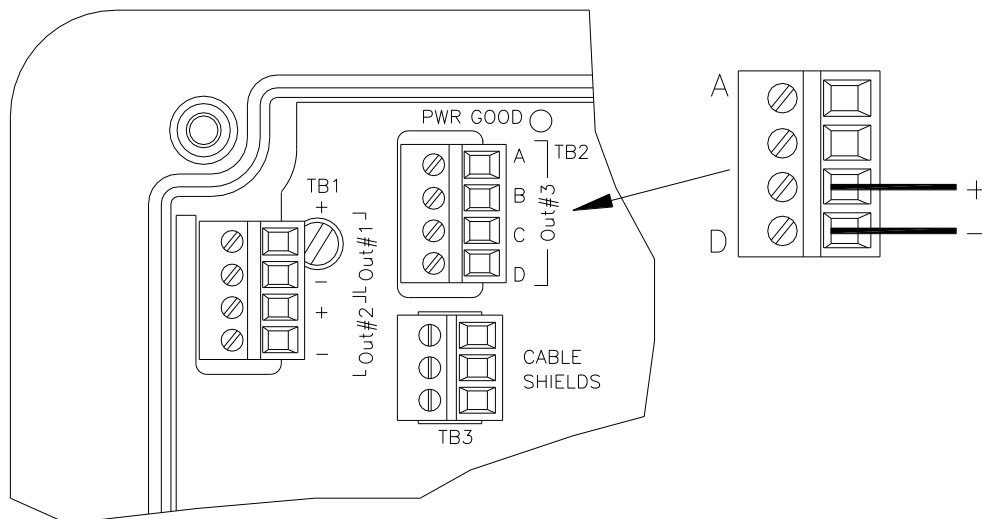

Figure 11 - Optional Analog Output Wiring

4.5 Sensor Wiring

The sensor cable can be quickly connected to the Q46 terminal strip by matching the wire colors on the cable to the color designations on the label in the monitor. A junction box is also available to provide a break point for long sensor cable runs. Route signal cable away from AC power lines, adjustable frequency drives, motors, or other noisy electrical signal lines. Do not run sensor or signal cables in conduit that contains AC power lines or motor leads.

When installing concentration monitors and sensors, we recommend keeping the sensor cable as short as is practical. This will minimize potential noise problems.

Standard convertible sensors, insertion sensors, and sanitary sensors have cable permanently attached to the sensor. This cable contains double shielded conductors to minimize noise problems in heavy industrial environments. Convertible sensors with connectors and flow type sensors use a slightly different cable assembly with only a single shield. This assembly is sufficient for many applications where EMI/RFI problems are not severe.



DANGER: DO NOT connect sensor cable to power lines. Serious injury may result.

Refer to Cable Description and **Figure 14**, Wiring Diagram for illustrative details on electrical installation.

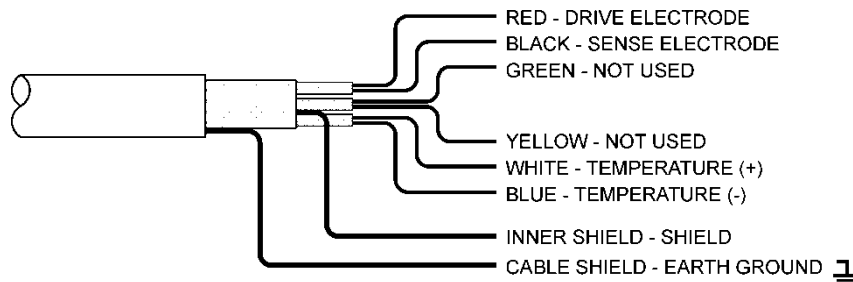

Figure 12 - Cable Description, Model Q25C2

Take care to route sensor cable away from AC power lines, adjustable frequency drives, motors, or other noisy electrical signal lines. Do not run signal lines in the same conduit as AC power lines. Run signal cable in dedicated metal conduit if possible. For optimum electrical noise protection, run an earth ground wire to the ground terminal in the transmitter.



Only ATI's custom 6-wire shielded interconnect cable must be used when connecting the Model Q25C2 sensor to the analyzer. This high-performance, double shielded, polyethylene jacketed cable is specially designed to provide the proper signal shielding for the sensor used in this system. No substitutions can be made. Substituted cables may cause problems with system performance.

Note: If sensor is experiencing Low-Slope or Low-Output conditions, due to poor Earth Ground Connections, move the Shield connection from P/S board to alternate location on lid, where indicated with an "S".

4.6 Direct Sensor Connection

Sensor connections are made in accordance with Figure 14. The sensor cable can be routed into the enclosure through one of cord-grips supplied with the unit. Routing sensor wiring through conduit is only recommended if a junction box is to be used. Some loose cable is needed near the installation point so that the sensor can be inserted and removed easily from the flowcell.

Cord-grips used for sealing the cable should be snugly tightened after electrical connections have been made to prevent moisture incursion. When stripping cables, leave adequate length for connections in the transmitter enclosure as shown below. The standard 15 ft. sensor cable normally supplied with the system is already stripped and ready for wiring. This cable can be cut to a shorter length if desired to remove extra cable in a given installation. Do not cut the cable so short as to make installation and removal of the sensor difficult.

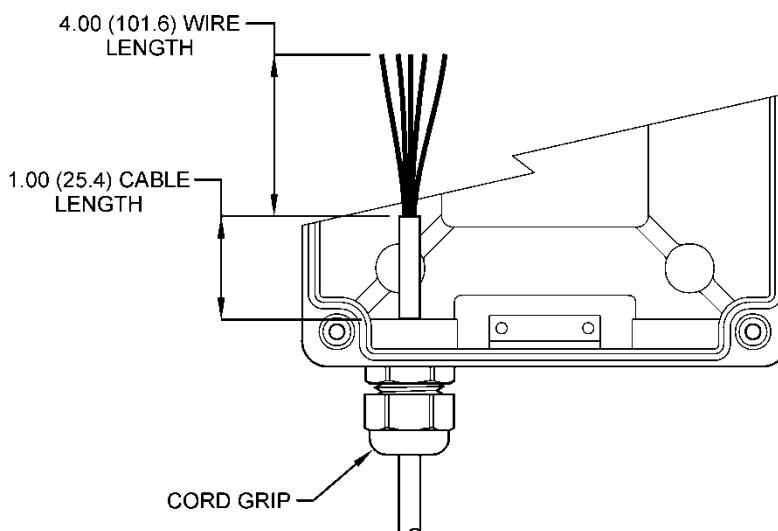

Figure 13 - Sensor Cable Preparation

4.7 Junction Box Connection

For installations where the sensor is to be located more than 30 feet from the monitor (max. 60 feet), a junction box must be used. The junction box is shown in Figure 14, and is supplied with a (2) Pg 9 cord grips for sensor and interconnect wiring.

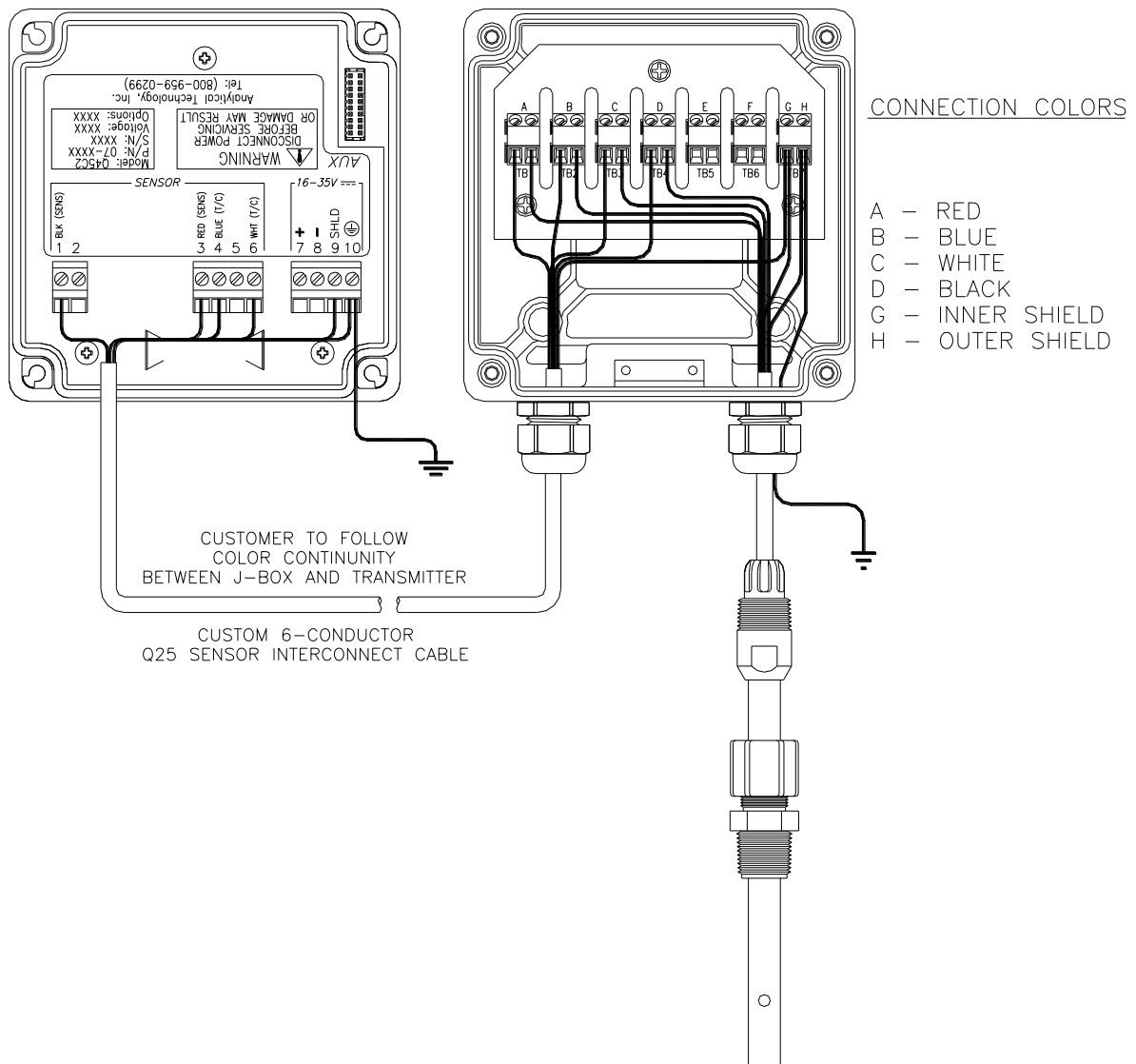

Figure 14 - Junction Box Interconnect Wiring

4.8 In-Line Sensor Connection

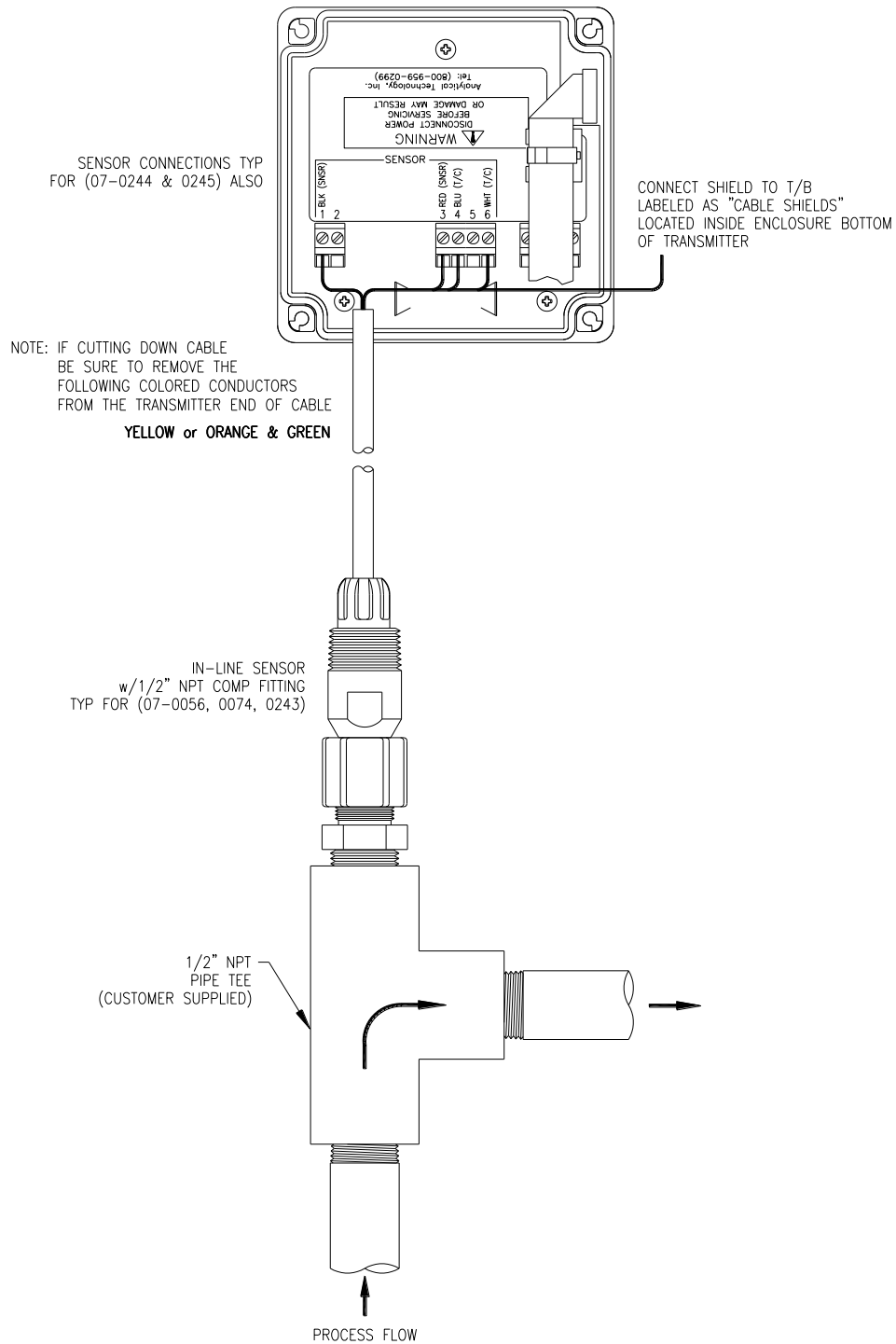

Figure 15 - In-Line Sensor Connection

4.9 OEM Sensor Connection

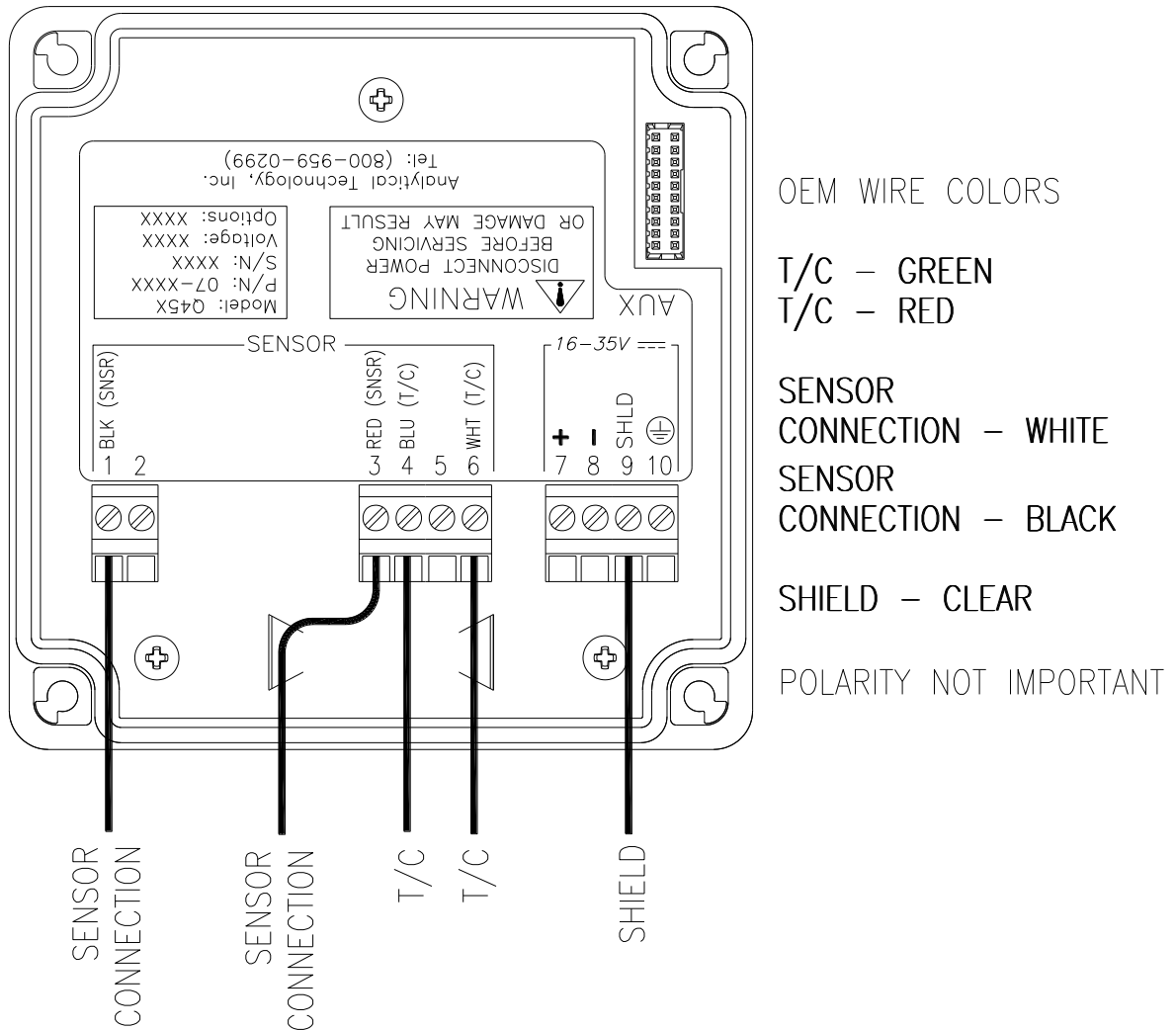

Figure 16 - OEM Sensor Connections

4.10 Sanitary Sensor Connection

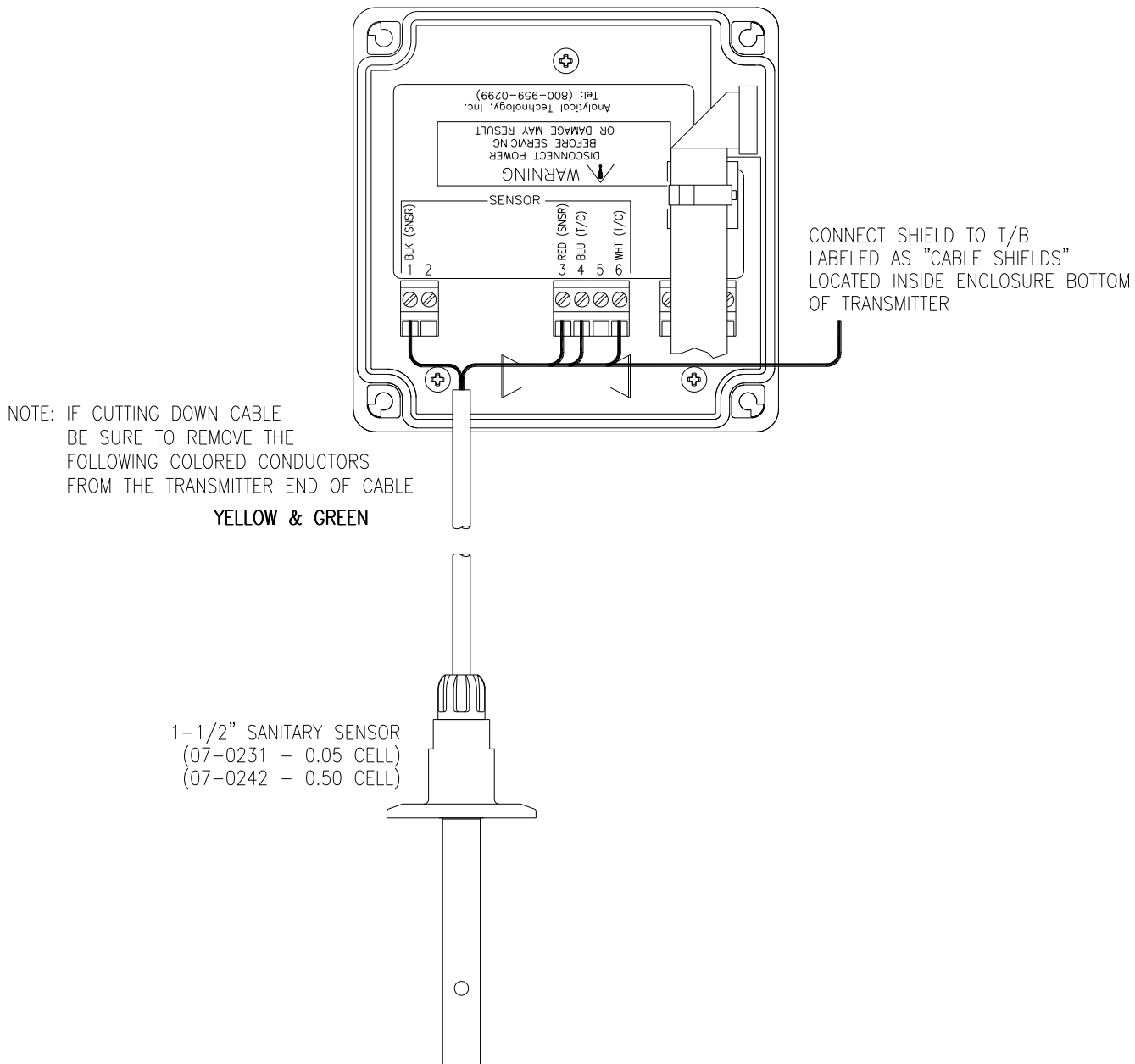

Figure 17 - Sanitary Sensor Wiring

Part 5 – Configuration

5.1 User Interface

The user interface for the Q46 Series instrument consists of a custom display and a membrane keypad. All functions are accessed from this user interface (no internal jumpers, pots, etc.).

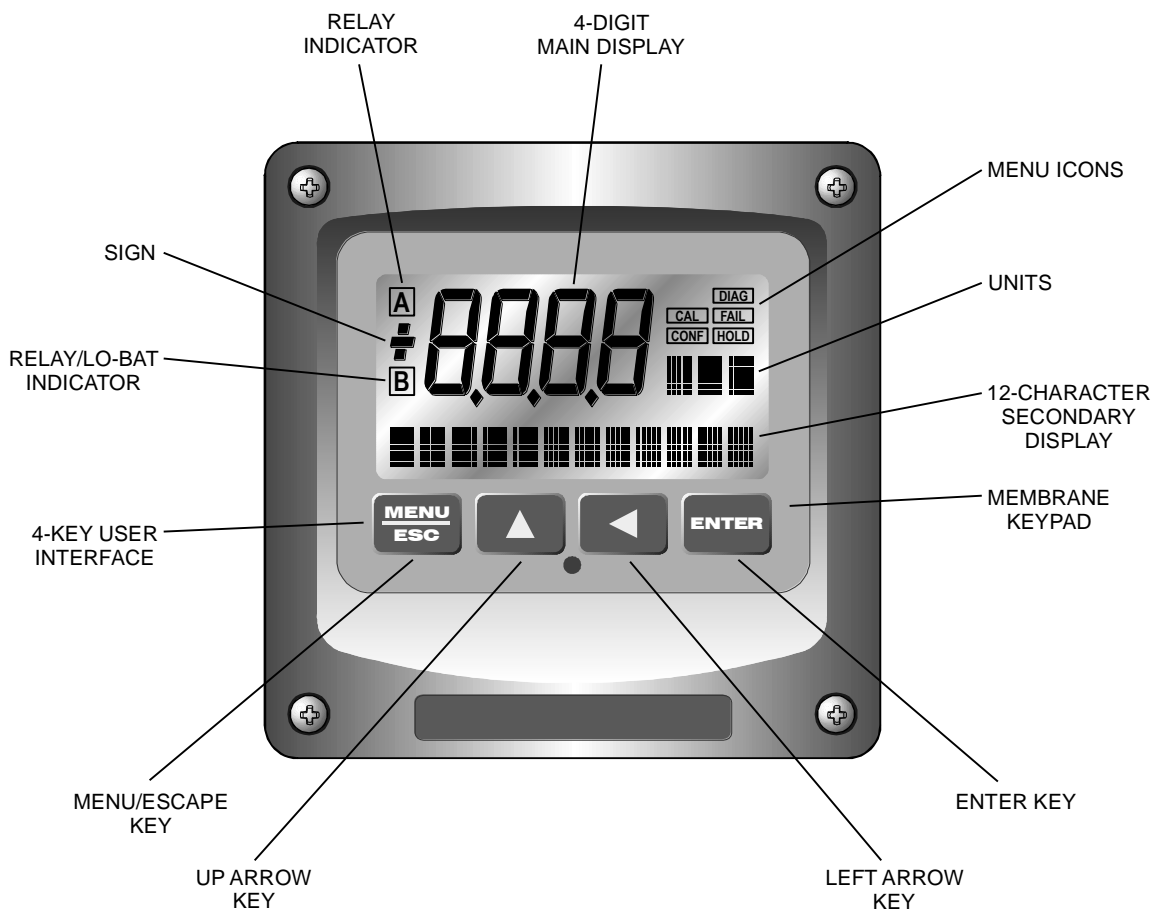

Figure 18 - User Interface

5.11 Keys

All user configurations occur through the use of four membrane keys. These keys are used as follows:

MENU/ESC	To scroll through the menu section headers or to escape from anywhere in software. The escape sequence allows the user to back out of any changes in a logical manner. Using the escape key aborts all changes to the current screen and backs the user out one level in the software tree. The manual will refer to this key as either MENU or ESC, depending upon its particular function.
UP (arrow)	To scroll through individual list or display items and to change number values.
LEFT (arrow)	To move the cursor from right to left during changes to a number value.
ENTER	To select a menu section or list item for change and to store any change.

5.12 Display

The large custom display provides clear information for general measurement use and user configuration. There are three main areas of the display: the main parameter display, the secondary message line, and the icon area.

Main Parameter During normal operation, the main parameter display indicates the present process input with sign and units. This main display may be configured to display any of the main measurements that the system provides. During configuration, this area displays other useful set-up information to the user.



Lower Line During normal operation, the lower line of the display indicates user-selected secondary measurements that the system is making. This also includes calibration data from the last calibration sequence and the transmitter model number and software version. During configuration, the lower line displays menu items and set-up prompts to the user. Finally, the lower line will display error messages when necessary. For a description of all display messages, refer to Section 10.3.

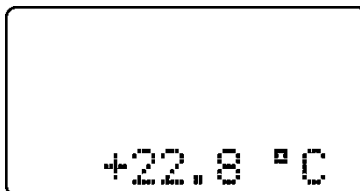

Icon Area

The icon area contains display icons that assist the user in set-up and indicate important states of system functions. The CAL, CONFIG, and DIAG icons are used to tell the user what branch of the software tree the user is in while scrolling through the menu items. This improves software map navigation dramatically. Upon entry into a menu, the title is displayed (such as CAL), and then the title disappears to make way for the actual menu item. However, the icon stays on.

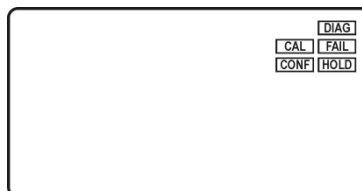

HOLD

The HOLD icon indicates that the current output of the transmitter has been put into output hold. In this case, the output is locked to the last input value measured when the HOLD function was entered. HOLD values are retained even if the unit power is cycled.

FAIL

The FAIL icon indicates that the system diagnostic function has detected a problem that requires immediate attention. This icon is automatically cleared once the problem has been resolved.

Relay Area A/B

The relay area contains two icons that indicate the state of the system relays. Relay C is normally configured for FAIL indication, so it is only displayed on the lower MEASURE display line.

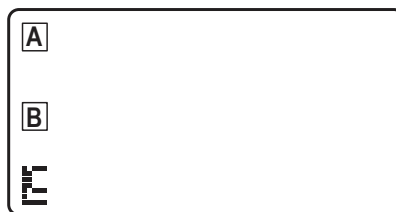

5.2 Software

The software of the Q46C2C is organized in an easy to follow menu-based system. All user settings are organized under five menu sections: Measure, Calibration [CAL], Configuration [CONFIG], Control [CONTROL] and Diagnostics [DIAG].

Note: The default Measure Menu is display-only and has no menu icon.

5.21 Software Navigation

Within the CAL, CONFIG, CONTROL, and DIAG menu sections is a list of selectable items. Once a menu section (such as CONFIG) has been selected with the MENU key, the user can access the item list in this section by pressing either the ENTER key or the UP arrow key. The list items can then be scrolled through using the UP arrow key. Once the last item is reached, the list wraps around and the first list item is shown again. The items in the menu sections are organized such that more frequently used functions are first, while more permanent function settings are later in the list. See Figure 1919 for a visual description of the software.

Each list item allows a change to a stored system variable. List items are designed in one of two forms: simple single variable, or multiple variable sequences. In the single variable format, the user can quickly modify one parameter - for example, changing temperature display units from °F to °C. In the multiple variable sequence, variables are changed as the result of some process. For example, the calibration of concentration generally requires more than one piece of information to be entered. The majority of the menu items in the software consist of the single variable format type.

Any data that may be changed will be flashing. This flashing indicates user entry mode and is initiated by pressing the ENTER key. The UP arrow key will increase a flashing digit from 0 to 9. The LEFT arrow key moves the flashing digit from right to left. Once the change has been completed, pressing ENTER again stores the variable and stops the flashing. Pressing ESC aborts the change and also exits user entry mode.

The starting (default) screen is always the Measure Menu. The UP arrow key is used to select the desired display. From anywhere in this section the user can press the MENU key to select one of the four Menu Sections.

The UP arrow icon next to all list items on the display is a reminder to scroll through the list using the UP arrow key.

To select a list item for modification, first select the proper menu with the MENU key. Scroll to the list item with the UP arrow key and then press the ENTER key. This tells the system that the user wishes to perform a change on that item. For single item type screens, once the user presses the ENTER key, part or all of the variable will begin to flash, indicating that the user may modify that variable using the arrow keys. However, if the instrument is locked, the transmitter will display the message **Locked!** and will not enter user entry mode. The instrument must be unlocked by entering the proper code value to allow authorized changes to user entered values. Once the variable has been reset, pressing the ENTER key again causes the change to be stored and the flashing to stop. The message **Accepted!** will be displayed if the change is within pre-defined variable limits. If the user decides not to modify the value after it has already been partially changed, pressing the ESC key aborts the modification and returns the entry to its original stored value.

In a menu item which is a multiple variable sequence type, once the ENTER key is pressed there may be several prompts and sequences that are run to complete the modification. The ESC key can always be used to abort the sequence without changing any stored variables.

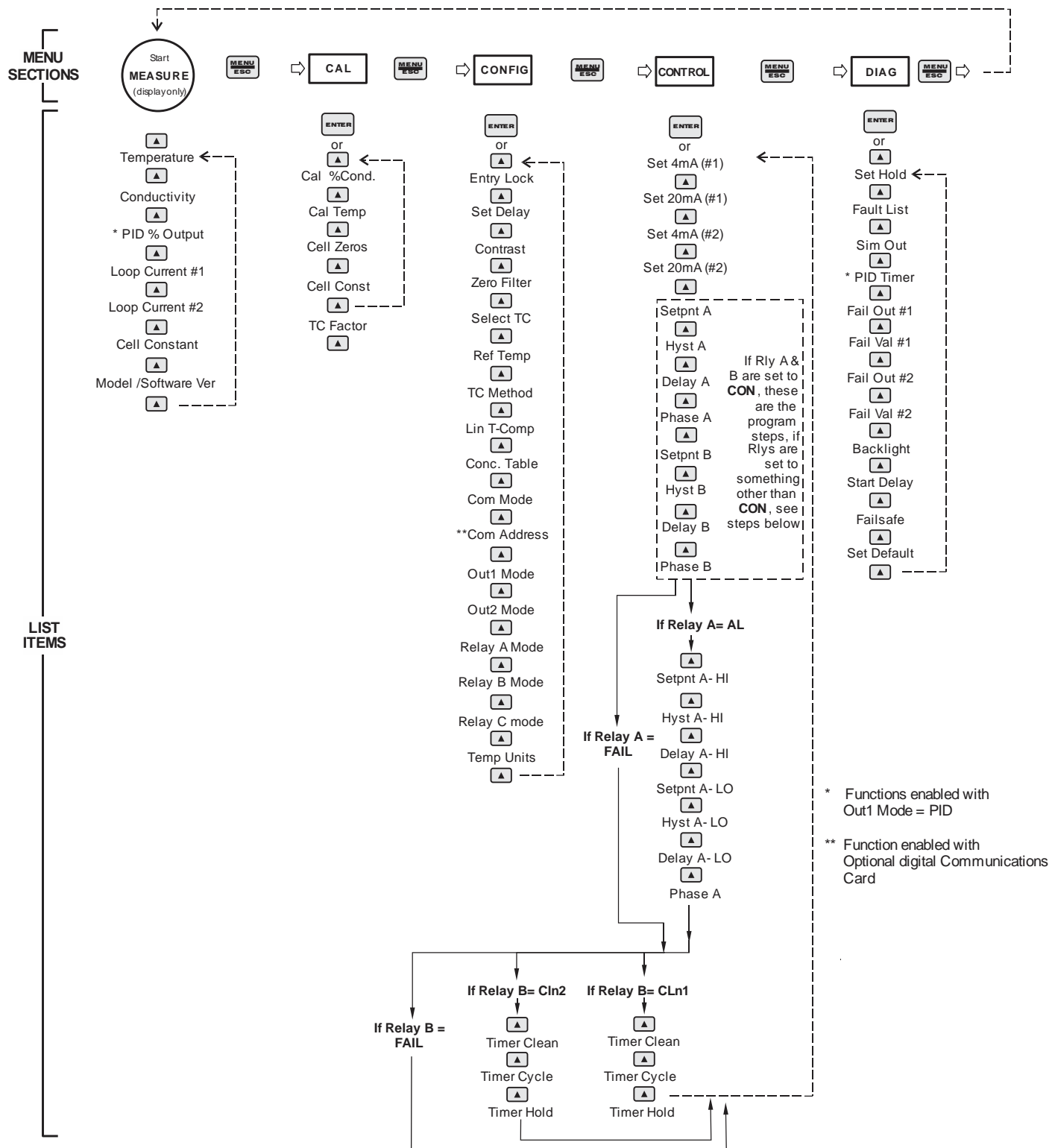

Figure 19 - Software Map

5.22 Measure Menu [MEASURE]

The default menu for the system is the display-only menu MEASURE. This menu is a display-only measurement menu, and has no changeable list items. When left alone, the instrument will automatically return to this menu after approximately 30 minutes. While in the default menu, the UP arrow allows the user to scroll through the secondary variables on the lower line of the display. A brief description of the fields in the basic transmitter version is as follows:

TRANSMITTER MEAS SCREENS:

25.7°C	Temperature display. Can be displayed in °C or °F, depending on user selection. A small “m” on the left side of the screen indicates the transmitter has automatically jumped to a manual 25°C setting due to a failure with the temperature signal input.
Conductivity	Displays Conductivity of process.
100% 20.00 mA	PID Status screen (if enabled.) Shows the present controller output level on left, and actual transmitter current on the right. The controller can be placed in manual while viewing this screen by pressing and holding the ENTER key for 5 seconds until a small flashing “m” appears on the screen. At that point the controller output can be adjusted up or down using the UP and LEFT arrow keys. To return to automatic operation, press and hold the ENTER key for 5 seconds and the “M” will disappear.
Loop Current #1	Indicates current output setting on TB1
Loop Current #2	Indicates current output setting on TB2
Cell Const	Indicates cell constant setting. See Part 7 - Calibration for more details.
Q46C2 v4.00	Transmitter software version number.

Note: A display test (all segments ON) can be actuated by pressing and holding the ENTER key while viewing the model/version number on the lower line of the display.

The MEASURE screens are intended to be used as a very quick means of looking up critical values during operation or troubleshooting.

5.23 Calibration Menu [CAL]

The calibration menu contains items for frequent calibration of user parameters. There are five items in this list: Cal %Conc, Cell Temp, Cal Zeros, Cell Const, and TC Factor.

Cal %Conc	The concentration calibration function allows the user to adjust the transmitter offset and span reading to match reference solution, or to adjust the sensor offset to match the sample reading. See Part 8 - Calibration for more details.
Cal Temp	The temperature calibration function allows the user to adjust the offset of the temperature response by a small factor of ± 5 °C. The temperature input is factory calibrated to very high accuracy. However, long cable

lengths and junction boxes may degrade the accuracy of the temperature measurement in some extreme situations. Therefore, this feature is provided as an adjustment. See Part 8 - Calibration for more details.

- Cal Zeros** This function calibrates all range zero-points to the specific sensor being used. This function is only required to be performed once at initial start-up or when the sensor has been replaced. See Part 8 - Calibration for more details.
- Cell Const** This function allows the user to directly enter the factory measured cell constant for the Q25C2 sensor. When this feature is used, calibration with reference solutions is not necessary. See Part 8 - Calibration for more details.
- TC Factor** This function allows the user to directly enter the factory measured temperature offset value marked on the sensor label. The default for this setting is 7.50 and most sensors are fairly close to that number

5.24 Configuration Menu [CONFIG]

The Configuration Menu contains all of the general user settings:

- Entry Lock** This function allows the user to lock out unauthorized tampering with instrument settings. All settings may be viewed while the instrument is locked, but they cannot be modified. The Entry Lock feature is a toggle-type setting; that is, entering the correct code will lock the transmitter and entering the correct code again will unlock it. The code is preset at a fixed value. Press ENTER to initiate user entry mode and the first digit will flash. Use arrow keys to modify value. **See end of manual for the Q46C2C lock/unlock code.** Press ENTER to toggle lock setting once code is correct. Incorrect codes do not change state of lock condition.
- Set Delay** The delay function sets the amount of damping on the instrument. This function allows the user to apply a first order time delay function to the concentration measurements being made. Both the display and the output value are affected by the degree of damping. Functions such as calibration are not affected by this parameter. The calibration routines contain their own filtering and stability monitoring functions to minimize the calibration timing. Press ENTER to initiate user entry mode, and the value will flash. Use the arrow keys to modify value; range is 0.1 to 9.9 minutes. Press ENTER to store the new value.
- Contrast** This function sets the contrast level for the display. The custom display is designed with a wide temperature range, Super-Twist Nematic (STN) fluid.
- The STN display provides the highest possible contrast and widest viewing angle under all conditions. Contrast control of this type of display is generally not necessary, so contrast control is provided as a means for possible adjustment due to aging at extreme ranges. In addition, the display has an automatic temperature compensation network. Press ENTER to initiate user entry mode, and the value will flash. Use arrow keys to modify the value; range is 0 to 8 (0 being lightest). Press ENTER to update and store the new value.

- Zero Filter** This function forces the reading to zero when reading is below the entered value. For example, If the entered value were 2.1 uS, the display would read 0.0 uS when the measured value reached 2.0 uS. This feature is useful in blanking out very small and meaningless zero variability.
- Select TC** The user can select the sensor temperature compensation element. The options are 100 ohm RTD or 1000 ohm RTD.
- Ref Temp** The reference temperature function sets the basis point for the linear temperature compensation methods. In most cases this setting should be left at the default of 25.0 °C.
- Press ENTER to initiate user entry mode, and the entire value will flash. Use the arrow keys to modify the desired value; range is 0.0°C to 50.0°C. Press ENTER to update and store the new value. This setting appears in the Software Menu only if “Temp Mode” is set to **Lin**.
- TC Method** This function allows selection of the method used for the temperature compensation in the instrument. The choices are **1-Lin** or **2-Table**. The Lin (linear) method is by far the most common and should be used unless special measurements are being made.
- Under the **2-Table** selection, a custom temperature compensation table is available. Up to six temperature points and corresponding TC factors can be entered by the user.
- This selection is critical for control of the internal diagnostics and compensation factors. Press ENTER to initiate user entry mode, and the entire value will flash. Use the UP arrow key to modify the desired value.***
- Lin T-Comp** This function sets the correction slope value for the linear temperature compensation method and is used when the “Temp Mode” is set to **Lin**. Linear compensation is the method recommended for most aqueous solutions, and the value is typically 2.00 %/°C (25°C reference temperature) for neutral water. This is the factory default and it provides the best compensation for most aqueous solutions. Other typical ranges include:
- Acids: 1.0 to 1.6%/°C
Bases: 1.8 to 2.0%/°C
Salts: 2.2 to 3.0%/°C
- NOTE:** If the temperature units are changed between °C and °F (see Temp Units in this Section), the default setting for this output will change between 2.00 %/°C and 1.11%/°F accordingly.
- Other compensation slopes for uncommon solutions may be found in chemical handbooks (such as the CRC). Press ENTER to initiate user entry mode, and the entire value will flash. Use the arrow keys to modify the desired value; entry range is 0.000%/°C (no compensation) to 4.000%/°C. Press ENTER to store the new value.

Conc Table	<p>This function enables the user to modify the pre-programmed table. There are six points in the table to enter solution conductivity and percent concentration values.</p> <p>Press ENTER to initiate user entry mode, and the entire value will flash. Use the arrow keys to modify the desired value. Press ENTER to update and store the new value. This process must be completed for all six conductivity/concentration data sets.</p>
Com Mode	<p>Sets digital communication mode of analyzer. Optional digital communication card must be plugged into the power supply slot for this function to work. Press ENTER to initiate user entry mode, and the entire value will flash. Use the UP arrow key to modify the desired value; selections include 1-None, 2- P-DP for Profibus DP, 3 – Modbus, 4 – Ethernet IP. Press ENTER to store the new value.</p>
Com Address	<p>Sets bus address for digital communication mode of analyzer. Optional digital communication card must be plugged into the power supply slot for this function to work. Press ENTER to initiate user entry mode, and the entire value will flash. Use the UP arrow key to modify the desired value. Range is 1-125. Press ENTER to store the value.</p>
Iout#1 Mode	<p>This assigns the 4-20 mA output #1 to either μS (by selecting 1) or for PID output (by selecting 2)</p>
Iout#2 Mode	<p>This assigns the 4-20 mA output # 2 to Temperature (by selecting 1), μS (by selecting 2) or TDS mg/L (by selecting 3)</p>
*Iout#3 Mode	<p>OPTIONAL. This function sets analog output #3 for temperature, concentration, or TDS. Press ENTER to initiate user entry mode, and the entire value will flash. Use the UP arrow key to modify the desired value; selections include 1-C/F for temperature, 2-uS, or 3-mg/l. Press ENTER to store the new value.</p>
Relay A Mode	<p>Relay A can be used in three different ways: as a setpoint control, as a fail alarm, or as a HI-LO alarm band. The three settings for Rly A Mode are CON, FAIL and AL.</p> <p>The CON setting enables normal control operation for Relay A, with settings for setpoint, hysteresis, delay and phasing appearing in the CONFIG menu automatically. See Figure 20 for further details.</p> <p>The FAIL setting enables the fail alarm mode for Relay A. Relay A will then trip on any condition that causes the FAIL icon to be displayed on the LCD. Using this mode allows the User to send alarm indications to other remote devices.</p> <p>The AL setting allows two setpoints to be selected for the same relay, producing a HI-LO alarm band. In this mode, Relay A will trip inside or outside of the band, depending upon the Phase selected. See Figure 21 for further details.</p>

Relay B Mode
Relay C Mode

Relay B and C can be used in two ways: as a setpoint control, or as an alarm. The two settings for Relay B Mode are **CON** and **FAIL**.

The **CON** setting enables normal setpoint operation for Relay B/C. Relay B/C then operates identically to Relay A, with settings for setpoint, hysteresis, delay and phasing appearing in the CONFIG menu automatically. See Figure 20 for details.

The **FAIL** setting enables the fail alarm mode for Relay B/C. Relay B/C will then trip on any condition that causes the FAIL icon to be displayed on the LCD. Note that the Relay C indicator shows up only on the lower screen of the display next to the temperature reading. This is because the default setting for relay C is the **FAIL** setting. Using this mode allows the User to send alarm indications to other remote devices. See Figure 21 for details.

***Relay D Mode**
***Relay E Mode**
***Relay F Mode**

OPTIONAL. Relays D, E, and F can be used in two ways: as a setpoint control, or as an alarm. The two settings for Relay B mode are **CON** and **FAIL**.

The **CON** setting enables normal setpoint operation for Relay B. Relay B then operates identically to Relay A, with settings for setpoint, hysteresis, delay and phasing appearing in the CONFIG menu automatically. See Figure 20 for details.

Temp Units

This function sets the display units for temperature measurement. Press ENTER to initiate user entry mode, and the entire value will flash. Use the UP arrow key to modify the desired display value. The choices are °F and °C. Press ENTER to store the new value.

Part 6 - Control

The Control Menu contains all of the output control user settings:

Set PID 0%
Set PID 100%
[lout1=PID]

If the PID is enabled, this function sets the minimum and maximum controller end points. Unlike the standard 4-20 mA output, the controller does not “scale” output values across the endpoints. Rather, the endpoints determine where the controller would normally force minimum or maximum output in an attempt to recover the setpoint (even though the controller can achieve 0% or 100% anywhere within the range.)

If the 0% point is lower than the 100% point, then the controller action will be “reverse” acting. That is, the output of the controller will increase if the measured value is less than the setpoint, and the output will decrease if the measured value is larger than the setpoint. Flipping the stored values in these points will reverse the action of the controller to “direct” mode.

The entry value is limited to a value within the range specified in “Set Range”, and the 0% and the 100% point must be separated by at least 1% of this range. Use the LEFT arrow key to select the first digit to be modified. Then use the UP and LEFT arrow keys to select the desired numerical value. Press ENTER to store the new value.

PID Setpnt
[lout1=PID]

The measured value which the controller is attempting to maintain by adjusting output value. It is the nature of the PID controller that it never actually gets to the exact value and stops. The controller is continually making smaller and smaller adjustments as the measured value gets near the setpoint.

PID Prop
[lout1=PID]

Proportional gain factor. The proportional gain value is a multiplier on the controller error (difference between measured value and setpoint value.) Increasing this value will make the controller more responsive.

PID Int
[lout1=PID]

Integral is the number of “repeats-per-minute” of the action of the controller. It is the number of times per minute that the controller acts on the input error. At a setting of 2.0 rpm, there are two repeats every minute. If the integral is set to zero, a fixed offset value is added to the controller (manual reset.) Increasing this value will make the controller more responsive.

PID Deriv
[lout1=PID]

Derivative is a second order implementation of Integral, used to suppress “second-order” effects from process variables. These variables may include items like pumps or mixers that may have minor impacts on the measured value. The derivative factor is rarely used and therefore it is best in most cases to leave it at the default value. Increasing this value will make the controller more responsive.

Set 4 mA (#1)
Set 20 mA (#1)

These functions set the main 4 and 20 mA current loop output points for the transmitter. The units displayed depend on the selection made in the CONFIG menu for lout #1 Mode. Typically, lout #1 is used for concentration/TDS.

The value stored for the 4 mA point may be higher or lower than the value stored for the 20 mA point. The entry values are limited to values separated by at least 1% of the range. Use the LEFT arrow key to select the first digit to be modified. Then use the UP and LEFT arrow keys to select the desired numerical value. Press ENTER to store the new value.

***Set 4 mA (#2)**
***Set 20 mA (#2)**
[temp/Conc./TDS]

These functions set the second 4 mA and 20 mA current loop output points for the transmitter. The output may be set to track temperature (default), or concentration. The values stored for the 4 mA point may be higher or lower than the value stored for the 20 mA point.

The entry value is limited to a value between 0 and 110°C if it is set for temperature, within the range specified in “Set Range” if the output is set to track concentration. The 4 mA and the 20 mA point must be at least 20 units away from each other. Press ENTER to initiate user entry mode, and the value will flash. Use arrow keys to modify value. Press ENTER to store the new value.

***Set 4 mA #3**
***Set 20 mA #3**
[temp/Conc/TDS]

OPTIONAL These functions set the optional third 4 mA and 20 mA current loop output points for the analyzer. The output may be set to track temperature (default), concentration, or TDS. The values stored for the 4 mA point may be higher or lower than the value stored for the 20 mA point.

The range is between 0 and 110°C if it is set for temperature, within the range specified in “Set Range” if the output is set to track concentration, and must be within the display range established by the conductivity range if set to track TDS. The 4 mA and the 20 mA point must be at least 20 units away from each other. Press ENTER to initiate user entry mode, and the value will flash. Use arrow keys to modify value. Press ENTER to store the new value.

***A Setpoint**

This function establishes the concentration trip point for relay A. The entry value is limited to a value within the range specified in “Set Range”. Use the LEFT arrow key to select the first digit to be modified. Then use the UP and LEFT arrow keys to select the desired numerical value. Press ENTER to store the new value.

***A Hysteresis**

This function establishes the hysteresis, or “deadband”, for Relay A. Hysteresis is most often used to control relay chattering; however, it may also be used in control schemes to separate the ON/OFF trip points of the relay. Press ENTER to initiate user entry mode, and the value will flash. Use the arrow keys to modify value. Press ENTER to store the new value.

***A Delay**

This function places an additional amount of time delay on the trip point for relay A. This delay is in addition to the main delay setting for the controller. The entry value is limited to a value between 0 and 999 seconds. Press ENTER to initiate user entry mode, and the value will flash. Use arrow keys to modify value; range is 0 to 999 seconds. Press ENTER to store the new value.

***A Phasing**

This function establishes the direction of the relay trip. When phase is HI, the relay operates in a direct mode. Therefore, the relay energizes and the LCD indicator illuminates when the concentration value **exceeds** the setpoint. When the phase is LO, the relay energizes and the LCD indicator illuminates when the concentration level drops **below** the setpoint. The failsafe setting does have an impact on this logic. The description here assumes the failsafe setting is OFF. Press ENTER to initiate user entry mode, and the entire value will flash. Use the UP arrow key to modify the desired value; selections include **HI** for direct operation or **LO** for reverse operation. Press ENTER to store the new value.

See Figure 20 below for a visual description of a typical control relay application.

When value rises to $\geq 1.000 \mu\text{S}$, relay closes.

When value falls to $\leq 1.000 \mu\text{S}$, relay opens.

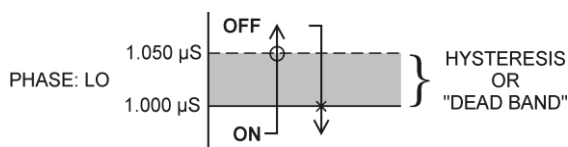
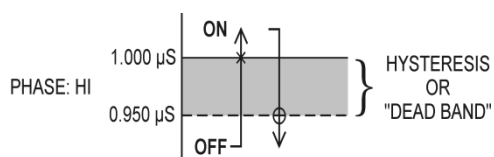

Settings: Setpoint: 1.000 μS
 Hyst: 0.050
 Delay: 000
 Failsafe: OFF

Figure 20 - Control Relay Example

- *Setpnt A-HI
- *Hyst A-HI
- *Delay A-HI
- *Setpnt A-LO
- *Hyst A-LO
- *Delay A-LO

If Relay A Mode is set to Alarm Mode, **AL**, then the following settings will appear in the Config Menu list automatically. In this mode, two setpoints can be selected on the same relay, to create an alarm band. Phase HI selection causes the relay to energize outside of the band, and Phase LO causes the relay to energize inside of the band. This feature enables one relay to be used as a control relay while the other is used as a HI-LO Alarm relay at the same time. Setpoint A-LO must be set lower than Setpoint A-HI. When AL mode is first selected, Setpoint A-LO is defaulted to 0.

Figure 21 is a visual description of a typical alarm relay application.

When value rises to $\geq 1.000 \mu\text{S}$, relay closes, until value falls back to $\leq 0.950 \mu\text{S}$.

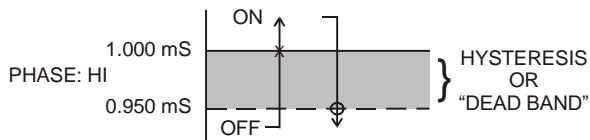

When value falls to $\leq 1.000 \mu\text{S}$, relay closes, until value rises back to $\geq 1.050 \mu\text{S}$.

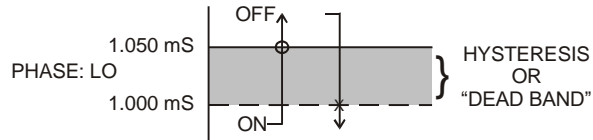

Settings :	Setpoint	A-HI: 1.000 μS	Setpoint	A-LO: 0.500 μS
	Hyst	A-HI: 0.050	Hyst	A-LO: 0.05
	Delay	A-HI: 000	Delay	A-LO: 000

Figure 21 - Alarm Relay Example

- *B Setpoint
- *B Hysteresis
- *B Delay
- *B Phasing

If Relay B Mode is set to **CON** (see **Relay B Mode**), then Relay B will function identically to Relay A. Relay B settings appear in the CONFIG menu list automatically.

Part - 7 Diagnostics Menu [DIAG]

The diagnostics menu contains all of the user settings that are specific to the system diagnostic functions, as well as functions that aid in troubleshooting application problems.

Set Hold

The Set Hold function locks the current loop output values on the present process value, and halts operation of the PID controller. This function can be used prior to calibration, or when removing the sensor from the process, to hold the output in a known state. Once HOLD is released, the outputs return to their normal state of following the process input. The transfer out of HOLD is bumpless on the both analog outputs - that is, the transfer occurs in a smooth manner rather than as an abrupt change. An icon on the display indicates the HOLD state, and the HOLD state is retained even if power is cycled. Press ENTER to initiate user entry mode, and entire value will flash. Use the UP arrow key to modify the desired value, selections are **ON** for engaging the HOLD function, and **OFF** to disengage the function. Press ENTER to store the new value. Note - the Set Hold function holds BOTH current levels, as well as ALL relay settings.

The Set Hold function can also hold at an output value specified by the user. To customize the hold value, first turn the HOLD function on. Press the ESC key to go to the DIAG Menu and scroll to Sim Output using the UP arrow key. Press ENTER. Follow the instructions under Sim Output (see following page).

CAUTION: There is no time-out on the hold feature. Once placed into hold mode, return to normal operation must be done manually.

Fault List

The Fault List screen is a read-only screen that allows the user to display the cause of the highest priority failure. The screen indicates the number of faults present in the system and a message detailing the highest priority fault present. Note that some faults can result in multiple displayed failures due to the high number of internal tests occurring. As faults are corrected, they are immediately cleared.

Faults are not stored; therefore, they are immediately removed if power is cycled. If the problem causing the faults still exists, however, faults will be displayed again after power is re-applied and a period of time elapses during which the diagnostic system re-detects them. The exception to this rule is the calibration failure. When a calibration fails, no corrupt data is stored. Therefore, the system continues to function normally on the data that was present before the calibration was attempted.

After 30 minutes or if power to the analyzer is cycled, the failure for calibration will be cleared until calibration is attempted again. If the problem still exists, the calibration failure will re-occur. Press ENTER to initiate view of the highest priority failure. The display will automatically return to normal after a few seconds.

Sim Out

The Sim Out function allows the user to simulate the chlorine level of the instrument in the user selected display range. The user enters a ppm value directly onto the screen, and the output responds as if it were actually receiving the signal from the sensor. This allows the user to

check the function of attached monitoring equipment during set-up or troubleshooting. Escaping this screen returns the unit to normal operation. Press ENTER to initiate the user entry mode, and the right-most digit of the value will flash. Use arrow keys to modify desired value.

The starting display value in SIM mode will be the last read value of the input. The output will be under control of the SIM screen until the ESC key is pressed. The instrument will automatically terminate the simulated output after 30 minutes and return to normal operation unless the "HOLD" function is engaged.

Note: If the HOLD function is engaged before the Sim Output function is engaged, the simulated output will remain the same even when the ESC key is pressed. Disengage the HOLD function to return to normal output.

PID Timer

This function sets a timer to monitor the amount of time the PID controller remains at 0% or 100%. This function only appears if the PID controller is enabled. If the timer is set to 0000, the feature is effectively disabled. If the timer value is set to any number other zero, a FAIL condition will occur if the PID controller remains at 0% or 100% for the timer value. If one of the relays is set to FAIL mode, this failure condition can be signaled by a changing relay contact.

Press ENTER to initiate user entry mode, and the entire value will flash. Use the UP arrow key to modify desired value; range of value is 0-9999 seconds. Press ENTER to store the new value.

Fail Out #1

This function enables the user to define a specified value that the main current output will go to under fault conditions. When enabled to **ON**, the output may be forced to the current value set in **Fail Val** (next item.) With the Fail Out setting of ON, and a Fail Val setting of 6.5 mA, any alarm condition will cause the current loop output to drop outside the normal operating range to exactly 6.5 mA, indicating a system failure that requires attention.

Press ENTER to initiate user entry mode, and the entire value will flash. Use the UP arrow key to modify desired value; selections are **ON**, **OFF**. Press ENTER to store the new value.

Fail Val #1

Sets the output failure value for lout#1. When **Fail Out** above is set to **ON**, this function sets value of the current loop under a FAIL condition. The output may be forced to any current value between 4-20 mA.

Press ENTER to initiate user entry mode, and the entire value will flash. Use the UP arrow key to modify desired value; selections are between **4mA**, and **20mA**. Press ENTER to store the new value.

Fail Val #2

This function sets the value of current loop output #2 under a FAIL condition. The settings and operation are identical to Fail Out for output #1.

*Fail Out #3

OPTIONAL. This function sets the fail-mode of current loop output #3 under a FAIL condition. The settings and operation are identical to Fail Out for output #1.

- *Fail Val #3** **OPTIONAL.** This function sets the value of current loop output #3 under a FAIL condition. The settings and operation are identical to Fail Out for output #1.
- Backlight** This function has three options. **ON** – On all the time, **OFF** – Off all the time, **AL** – Alarm (Default). This function flashes the backlight on and off whenever the Fail icon is displayed.
- Failsafe** This function allows the user to set the optional system relays to a failsafe condition. In a failsafe condition, the relay logic is reversed so that the relay is electrically energized in a normal operating state. By doing this, the relay will not only change state when, for example, a chlorine limit is exceeded, but also when power is lost to the controller.
- When failsafe is selected to be ON, the normally-open contacts of the relay will be closed during normal operation. In an attempt to make this configuration less confusing, the LCD icon logic is reversed with this setting, and the icon is OFF under this normal condition. Therefore, when the trip condition occurs, the closed N.O. contacts will be opened (relay de-energized), and the LCD icon will illuminate. In addition, a power fail would also cause the contacts to open.
- Start Delay** This function is designed to minimize control or alarm issues arising from temporary power loss. When power goes down, the monitor records the analog output values and the status of relays and PID functions. When power is restored, the analog values and relays will be held at the pre-power loss values for a defined period of time. This “start delay” may be programmed for periods from 0-9.9 minutes. This function is set to 0.0 minutes by default and must be activated by the user if desired by setting a positive time value
- Set Default** The Set Default function allows the user to return the instrument back to factory default data for all user settings or for just the calibration default. It is intended to be used as a last resort troubleshooting procedure. All user settings or the calibration settings are returned to the original factory values. Hidden factory calibration data remains unchanged. Press ENTER to initiate user entry mode and select either All or CAL with the UP arrow key.

Part 8 – Calibration

8.1 Overview and Methods

Calibration of the Q46C2C is required to accurately match the sensor characteristics to the monitor/analyzer. Since the output of the conductivity sensor does not degrade over time, it is typically only required that the sensor be calibrated at initial installation and then cleaned periodically, to maintain proper system accuracy.

Since the conductivity of a solution is greatly affected by temperature, proper settings for thermal compensation are critical for accurate operation. Before calibrating the instrument for the very first time, it is important to select the proper operating parameters in the configuration menus for temperature compensation methods.

When using conductivity calibration standards for a wet calibration, take care not to inadvertently contaminate the reference solution; always thoroughly clean the sensor, rinsing off in tap water, and then finish rinsing in pure or de-ionized water. In addition, note that calibration solutions less than 20 μS can be very unstable and are only accurate at the labeled reference temperature. Moving the sensor back and forth between different value conductivity reference solutions can quickly contaminate the solutions and render them inaccurate.

The system provides two methods of conductivity calibration: 1-point (wet calibration) and cell constant. These two methods are significantly different. In addition, a sensor zero-cal is used on initial installation to set the range zeros for the sensor used. See Sections 5.11 through 5.12 for brief descriptions of their uses.

8.11 1-Point Calibration Explained

The 1-point calibration method is generally known as the "grab sample" calibration method. In the 1-point calibration method, the sensor may be removed from the application and placed into a reference solution. It may also be left in the measurement process and calibrated by reference. The 1-point calibration adjusts the sensor slope to match the exact calibration point. Readings beyond that point are then extrapolated from the determined slope of the calibration line. Since the sensor slope does not degrade over time, frequent re-calibration is unnecessary. Calibration accuracy can be optimized by calibrating with a reference solution which is close to the values typically measured.

8.12 Cell Constant Calibration Explained

In a cell constant calibration, the User simply enters the known cell constant of the sensor. This value is labeled on the sensor along with the TC factor value. It is the recommended method of calibration for highest accuracy. It is also the easiest and fastest method of initial calibration because it involves no reference solutions. The Cell Constant method cannot be used if the sensor cable length has been altered from the length at which it was originally ordered. If the cable length has been altered, utilize the 1-point calibration method instead.

8.13 Zero Calibration Explained

Sensor offset must be set for the system only on initial sensor installation, or whenever the cable length has been altered. The Zero Cal method establishes all of the sensor offset points for the instrument's ranges of operation.

8.2 Performing a 1-Point Calibration

This calibration method is intended to be used as an on-line calibration method or a wet-cal with reference solutions. During calibration, the system will display the current conductivity reading, and the user can manually enter a reference value from a reference solution bottle or a comparative reference instrument.

For wet calibrations, the user may use pre-made calibration references (also available from ATI) or a NaCl solution may be made using pure, dried NaCl crystals and one liter of high purity, de-ionized, CO₂-free water as mixed in the table shown in Figure 7-1. All table data is at 25°C - therefore, the sensor must be at this temperature to calibrate properly using the table data. If another reference calibration solution is being used, be sure to note temperature of reference solution before calibration. Since the sensor must ideally be at the specified temperature, wet calibrations can be difficult to perform accurately.

NaCl Reference Solution for Calibration (25°C)		
μS/cm	NaCl (gm)	NaCl (mg/L)
100	0.05	50
200	0.10	100

Figure 22 - NaCl Reference Solution for Calibration

During the 1-point calibration, the User must be careful to calibrate with a solution that falls into the measuring range selected. If the calibration solution is outside the measuring range, an error will result.

Procedure

1. Determine whether the calibration will be done on-line or with the sensor removed and placed into a reference solution. If the sensor is removed from the application, rinse and clean.
2. If the sensor has been removed and placed into a solution, allow sensor to temperature equilibrate with the solution as much as possible. With the sensor coming from an application that differs greatly in temperature, the user may have to wait as much as 5 minutes. If the sensor is on-line, the user may want to set the output HOLD feature prior to calibration to lock out any output fluctuations.
3. Scroll to the CAL menu section using the MENU key and press ENTER or the UP arrow key. **Cal %Conc** will then be displayed.
4. Press the ENTER key and the lower line of the display will prompt the user to **Place the sensor in reference solution**. Press the ENTER key.
5. The screen will display the last measured conductivity value and a message will be displayed prompting the user for the lab value. The user must then modify the screen value with the arrow keys and press ENTER. The system then performs the proper checks.

6. The system now begins acquiring data for the calibration value. As data is gathered, the units for conductivity and temperature may flash. Flashing units indicate that this parameter is unstable. The calibration data point acquisition will stop only when the data remains stable for a pre-determined amount of time. This can be overridden by pressing ENTER. If the data remains unstable for 10 minutes, the calibration will fail and the message **Cal Unstable** will be displayed.
7. The screen will display the last measured conductivity value and a message will be displayed prompting the user for the lab value. The user must then modify the screen value with the arrow keys and press ENTER. The system then performs the proper checks.
8. If accepted, the screen will display the message **PASS** with the cell constant value, and then it will return to the main measurement display. If the calibration fails, a message indicating the cause of the failure will be displayed and the FAIL icon will be turned on.
9. If this is a first-time installation or the sensor has just been replaced, also perform a zero-cal as described in Section 7.4.

8.3 Performing a Cell Constant Calibration

The Cell Constant calibration method utilizes a factory measured cell constant for the sensor. No solutions are required for a cell factor calibration.

The cell constant represents the physical electrode characteristics of the sensor. The surface area of the electrodes, the spacing of the electrodes and the sensor cable all contribute to cell constant of the sensor. By entering the factory cell value labeled on the sensor cable, the Q46C2C adjusts the factory calibration to match the characteristics of the specific sensor being used.

The cell constant value may be entered at any time, and it is not necessary to move or prepare the sensor in any way. Once this number is entered, the system is ready to use. Note that if the sensor cable length is adjusted (cut or extended) the cell constant data on the sensor label may be inaccurate for calibration. At this point, the 1-point calibration should be used.

Procedure

1. Scroll to the CAL menu section using the MENU key and press ENTER or the UP arrow key. Press the UP arrow key until **Cell Const** is displayed.
2. Press the ENTER key. The screen will display a flashing value for the cell factor. Using the arrow keys, enter the cell factor number from the label on the sensor and press ENTER. Ranges of acceptable values are 0350 - 0650 (0.05 cell), 3500 - 6500 (0.5 cell) and 0667 - 1330 (1.0 cell).
3. If this is first-time installation or the sensor has just been replaced, also perform a zero-cal as described in Section 8.4.

8.4 Performing a Sensor Zero Calibration

The sensor offset must be set for the system only on initial sensor installation, or when the cable length has been altered.

To begin the sensor zero cal, verify that the sensor is connected and VERY clean and dry. It should be held in the air with the electrodes at least 1 foot away from any nearby objects.

Procedure

1. Scroll to the CAL menu section using the MENU key and press ENTER or the UP arrow key. Zero **Cal** will then be displayed.
2. Press the ENTER key. The screen will automatically scroll through all ranges and establish and store the proper zero points.

8.5 Temperature Calibration

The temperature input is factory calibrated for the highest accuracy. Temperature calibration is not recommended; however, it is provided for applications in which very long cable lengths are needed. For example, at 50 feet, readings may be off ± 0.2 °C.

The temperature calibration sequence is essentially a 1-point offset calibration that allows adjustments of approximately ± 5 °C.

The sensor temperature may be calibrated on line, or the sensor can be removed from the process and placed into a known solution temperature reference. In any case, it is critical that the sensor be allowed to reach temperature equilibrium with the solution in order to provide the highest accuracy. When moving the sensor between widely different temperature conditions, it may be necessary to allow the sensor to stabilize as much as one hour before the calibration sequence is initiated. If the sensor is on-line, the user may want to set the output HOLD (see section 4.25) feature prior to calibration to lock out any output fluctuations.

Procedure

1. Scroll to the CAL menu section using the MENU key and press ENTER or the UP arrow key.
2. Press the UP arrow key until **Cal Temp** is displayed.
3. Press the ENTER key. The message **Place sensors in solution then press ENTER** will be displayed. Move the sensor into the calibration reference (if it hasn't been moved already) and wait for temperature equilibrium to be achieved. Press ENTER to begin the calibration sequence.
4. The message **Adjust temp value then press ENTER** will be displayed, and the right-most digit will begin to flash, indicating that the value can be modified. Using the UP and LEFT arrow keys, modify the value to the known ref solution temperature. Adjustments up to ± 5 °C from the factory calibrated temperature are allowed. Press ENTER.
5. The calibration data gathering process will begin. The message **Wait** will flash as data is accumulated and analyzed. The °C or °F symbol may flash periodically if the reading is too unstable.

6. Once completed, the display will indicate **PASS** or **FAIL**. If the unit fails, the temperature adjustment may be out of range, the sensor may not have achieved complete temperature equilibrium, or there may be a problem with the temperature element. In the event of calibration failure, it is recommended to attempt the calibration again immediately.

8.6 TC Factor Calibration

This function is intended to give the user direct control of the temperature calibration offset value without having to proceed through the temperature calibration procedure. Sensor TC offset is a number that indicates the sensor RTD output at 0 °C. Ideally, the sensor temperature output will be 0 °C (1000 Ohms) under these conditions. Sensor offset is primarily the result of sensor RTD tolerance and connecting cable resistance. Large offsets are typically the result of large sensor cable lengths. A sensor reading of +1 °C indicates that the sensor will output an uncalibrated reading of +1 °C when placed in a theoretically perfect 0 °C temperature bath. In other words, the offset shifts the entire sensor response curve up or down. Since the slope of an RTD is fixed and highly repeatable, the slope is not adjusted in this calibration.

Certain Q25 series sensors are labeled with a specific TC factor. Entering this factor directly allows the user to quickly calibrate the transmitter for the sensor being used without performing a time consuming full temperature calibration. However, if the sensor cable length is modified or a new sensor is used, a new TC factor must be entered or the user must perform a full temperature calibration. The default value for the TC factor is 7.50. Increasing this value increases the temperature reading and decreasing the value decreases the temperature reading. A change of approximately +0.1 is equivalent to +0.1 °C. This function is directly related to the full temperature calibration function in that a new offset number is produced if a full temperature calibration has already been performed. If the TC factor is modified, it overrides any previous full temperature calibration data.

Procedure

Press ENTER to initiate user entry mode and the first digit will flash. Use arrow keys to modify value; range is 00.00 to 15.00. Press ENTER to save the new value.

Part 9 – PID Controller Details

9.1 PID Description

PID control, like many other control schemes, are used in chemical control to improve the efficiency of chemical addition or control. By properly tuning the control loop that controls chemical addition, only the amount of chemical that is truly required is added to the system, saving money. The savings can be substantial when compared to a system which may be simply adding chemical at a constant rate to maintain some minimal addition under even the worst case conditions. The PID output controller is highly advantageous over simple control schemes that just utilize direct (proportional only) 4-20 mA output connections for control, since the PID controller can automatically adjust the “rate” of recovery based on the error between the setpoint and the measured value – which can be a substantial efficiency improvement..

The PID controller is basically designed to provide a “servo” action on the 4-20 mA output to control a process. If the user requires that a measured process stay as close as possible to a specific setpoint value, the controller output will change from 0% to 100% in an effort to keep the process at the setpoint. To affect this control, the controller must be used with properly selected control elements (valves, proper chemicals, etc.) that enable the controller to add or subtract chemical rapidly enough. This is not only specific to pumps and valves, but also to line sizes, delays in the system, etc.

This section is included to give a brief description of tuning details for the PID controller, and is not intended to be an exhaustive analysis of the complexities of PID loop tuning. Numerous sources are available for specialized methods of tuning that are appropriate for a specific application.

9.2 PID Algorithm

As most users of PID controllers realize, the terminology for the actual algorithm terms and even the algorithms themselves can vary between different manufacturers. This is important to recognize as early as possible, since just plugging in similar values from one controller into another can result in dramatically different results. There are various basic forms of PID algorithms that are commonly seen, and the implementation here is the most common version; The ISA algorithm (commonly referred to as the “ideal” algorithm.)

$$output = P \left[e(t) + \frac{1}{I} \int e(t) dt + D \frac{de(t)}{dt} \right]$$

Where:

output =	controller output
P =	proportional gain
I =	integral gain
D =	derivative gain
t =	time
e(t) =	controller error (e=measured variable – setpoint)

Figure 23 - Q46 ISA (Ideal) Equation

The most notable feature of the algorithm is the fact the proportional gain term affects all components directly (unlike some other algorithms - like the “series” form.) If a pre-existing controller utilizes the same form of the algorithm shown above, it is likely similar settings can be made if the units on the settings are exactly the same. Be careful of this, as many times the units are the reciprocals of each other (i.e. reps-per-min, sec-per-rep.)

PID stands for “proportional, integral, derivative.” These terms describe the three elements of the complete controller action, and each contributes a specific reaction in the control process. The PID controller is designed to be primarily used in a “closed-loop” control scheme, where the output of the controller directly affects the input through some control device, such as a pump, valve, etc.

Although the three components of the PID are described in the setting area (Section 6), here are more general descriptions of what each of the PID elements contribute to the overall action of the controller.

- P Proportional gain. With no “I” or “D” contribution, the controller output is simply a factor of the proportional gain multiplied by the input error (difference between the measured input and the controller setpoint.) Because a typical chemical control loop cannot react instantaneously to a correction signal, proportional gain is typically not efficient by itself – it must be combined with some integral action to be useful. Set the P term to a number between 2-4 to start. Higher numbers will cause the controller action to be quicker.
- I Integral gain. Integral gain is what allows the controller to eventually drive the input error to zero – providing accuracy to the control loop. It must be used to affect the accuracy in the servo action of the controller. Like proportional gain, increasing integral gain results in the control action happening quicker. Set the I term to a number between 3-5 to start (1-2 more than P). Like proportional gain, increasing the integral term will cause the controller action to be quicker.
- D Derivative gain. The addition of derivative control can be problematic in many applications, because it greatly contributes to oscillatory behavior. In inherently slow chemical control processes, differential control is generally added in very small amounts to suppress erratic actions in the process that are non-continuous, such as pumps and valves clicking on and off. However, as a starting point for chemical process control, its best to leave the “D” term set to 0.

Based on these descriptions, the focus on tuning for chemical applications really only involves adjustment of “P” and “I” in most cases. However, increasing both increases the response of the controller. The difference is in the time of recovery. Although combinations of high “P’s” and low “I” will appear to operate the same as combinations of low “P’s” and high “I’s”, there will be a difference in rate of recovery and stability. Because of the way the algorithm is structured, large “P’s” can have a larger impact to instability, because the proportional gain term impacts all the other terms directly. Therefore, keep proportional gain lower to start and increase integral gain to achieve the effect required.

Many of the classical tuning techniques have the user start with all values at 0, and then increase the P term until oscillations occur. The P value is then reduced to ½ of the oscillatory value, and the I term is increased to give the desired response. This can be done with the Q46 controller, with the exception that the I term should start no lower than 1.0.

If it appears that even large amounts of integral gain (>20) don’t appreciably increase the desired response, drop I back to about 1.0, and increase P by 1.00, and start increasing I again. In most chemical control schemes, I will be approximately 3 times the value of P.

9.3 Classical PID Tuning

Unlike many high speed position applications where PID loops are commonly used, the chemical feed application employed by this instrument does not require intense mathematical exercise to determine tuning parameters for the PID. In fact, the risk of instability is far greater with overly tuned PID control schemes. In addition, many of the classical mathematical exercises can be damaging or wasteful in the use of chemicals when the process is bumped with large amounts of input error to seek a response curve. Because of this, the general adjustment guidelines described in section 9.2 PID Algorithm are sufficient for almost all application tuning for this instrument. Beyond this, many sources are available for classical tuning methods.

9.4 Manual PID Override Control

The Q46 PID output function allows the user to take manual control of the PID control signal. This is often useful when starting up a control loop, or in the event that you wish to bump the system manually to measure system response time.

To access the manual PID control, you must be in the MEASURE mode of operation and you must have the PID output displayed on the lower line. This line will indicate “XX.X% XX.X mA” with the X values simply indicating the current values. With this display on the screen, press and hold the ENTER key for about 5 seconds. You will see a small “m” show up between the % value and the mA value. This indicates you are now in manual mode.

Once in manual, you may increase the PID output by pressing the UP arrow or you may decrease the output by pressing the LEFT arrow. This will allow you to drive the PID output to any desired setting.

To revert to normal PID control, press and hold the ENTER key again until the “m” indicator disappears.

9.5 Common PID Pitfalls

The most common problem occurring in PID control applications involves the false belief that proper settings on only the PID controller can balance any process to an efficient level.

Close-loop control can only be effective if all elements in the loop are properly selected for the application, and the process behavior is properly understood. Luckily, the nature of simple chemical control processes are generally slow in nature. Therefore, even a de-tuned controller (one that responds somewhat slowly) can still provide substantial improvements to setpoint control. In fact, damaging oscillatory behavior is far more likely in tightly tuned controllers where the user attempted to increase response too much.

When deciding on a PID control scheme, it is important to initially review all elements of the process. Sticking valves, undersized pumps, or delays in reaction times associated with chemical addition can have a dramatic effect on the stability of the control loop. When controlling a chemical mix or reaction, the sensor should be placed in a location that ensures proper mixing or reaction time has occurred.

The easiest processes to control with closed-loop schemes are generally linear, and symmetrical, in nature. For example, controlling level in tank where the opening of valve for a fixed period of time corresponds linearly to the amount that flows into a tank. Chemical control processes can be more problematic when the nature of the setpoint value is non-linear relative to the input of chemical added. For example, pH control of a process may appear linear only in a certain range

of operation, and become highly exponential at the extreme ranges of the measuring scale. In addition, if a chemical process is not symmetrical, that means it responds differentially to the addition and subtraction of chemical. It is important in these applications to study steady-state impact as well as step-change impact to process changes. In other words, once the process has apparently been tuned under normal operating conditions, the user should attempt to force a dramatic change to the input to study how the output reacts. If this is difficult to do with the actual process input (the recommended method), the user can place the control in manual at an extreme control point such as 5% or 95%, and release it in manual. The recovery should not be overly oscillatory. If so, the loop needs to be de-tuned to deal with that condition (reduce P and/or I.)

Part 10 – System Maintenance



WARNING: EXPLOSION HAZARD - SUBSTITUTION OF COMPONENTS MAY IMPAIR SUITABILITY FOR CLASS I, DIVISION 2.

10.1 System Checks

1. If the FAIL icon is flashing on the display, check the Fault List to determine the cause of the failure. To access the Fault List, press the MENU/ESC key until the DIAG menu appears. Then press the UP arrow key until the Fault List appears. Press the ENTER key to access the Fault List, and the highest priority fault message will be displayed. For a list of all messages and possible causes/solutions, refer to Section 10.3.
2. In **ALL** environments, connect an earth ground jumper to earth terminal connection on transmitter.
3. Perform a two-point calibration with two fresh buffers prior to sensor installation
4. Check sensor cable color to terminal strip markings.
5. For highly unstable behavior, remove sensor from the process and measure the process solution in a plastic beaker. If the reading now stabilizes, place wire in beaker solution and actual process solution to determine if a ground loop exists.
6. Verify that the black rubber shipping boot has been removed from the end of the sensor prior to submersion. If the sensor has been left to dry out, allow sensor to be submerged in buffer or water to re-hydrate for at least 4 hours. The saltbridge may need replacement if the sensor has dried out for too long.
7. If the instrument 4-20 mA output is connected into other control systems, disconnect output loop from system load and run through a handheld DMM to monitor current. Verify that the system operates correctly in this mode first.

10.2 Instrument Checks

1. Remove sensor completely and connect 1100 Ohms from the blue to white sensor input leads. Make sure the unit is configured for a Pt1000 thermal element and that the temperature is not in manual locked mode. The temperature reading should display approximately 25 °C and the conductivity reading should display approximately 0.0 uS.
2. With sensor disconnected, measure between all of the sensor leads (except between blue and white) with a DMM, and verify that no short exists.

10.3 Display Messages

The Q46 Series instruments provide a number of diagnostic messages that indicate problems during normal operation and calibration. These messages appear as prompts on the secondary line of the display or as items on the Fault List (see Part 7).

The following messages will appear as prompts:

MESSAGE	DESCRIPTION	POSSIBLE CORRECTION
Max is 200	Entry failed, maximum value allowed is 200.	Reduce value to ≤ 200
Min is 200	Entry failed, minimum value allowed is 200.	Increase value to ≥ 200
Cal Unstable	Calibration problem, data too unstable to calibrate.	Clean sensor, get fresh cal solutions, allow temperature and conductivity readings to fully stabilize, do not handle sensor or cable during calibration.
Out of Range	Input value is outside selected range of the specific list item being configured.	Check manual for limits of the function to be configured.
Locked!	Transmitter security setting is locked.	Enter security code to allow modifications to settings.
Unlocked!	Transmitter security has just been unlocked.	Displayed just after security code has been entered.
TC-F25 lock!	The TC selection is in F25 mode, locked at 25 °C	Calibration and TC adjustment cannot be performed while the TC is in F25 mode. To allow access to TC calibrations, change TC mode from F25 (fixed 25) to SENS (sensor).

The following messages will appear as items on the Fault List:

MESSAGE	DESCRIPTION	POSSIBLE CORRECTION
Sensor High	The raw signal from the sensor is too high.	Check wiring connections to sensor.
Sensor Low	The raw signal from the sensor is too low.	Check wiring connections to sensor.
Cond High	The conductivity reading is greater than the maximum of the User-selected range.	The conductivity reading is over operating limits. Set measuring range to the next highest level.
Temp High	The temperature reading is > 210 °C.	The temperature reading is over operating limits. Check wiring and expected temp level. Perform RTD test as described in sensor manual. Recalibrate sensor temperature element if necessary.
Temp Low	The temperature reading is < -10 °C	The temperature reading is under operating limits. Check wiring and expected temp level. Perform RTD test as described in sensor manual. Recalibrate sensor temperature element if necessary.
TC Error	TC may be open or shorted.	Check sensor wiring and perform RTD test as described in sensor manual.

Fault List display messages (continued):

MESSAGE	DESCRIPTION	POSSIBLE CORRECTION
Cond Cal Fail	Failure of conductivity calibration.	Clean sensor, get fresh cal solutions and redo calibration. If still failure, sensor slope may be less than 70% or greater than 130%. Perform sensor tests as described in sensor manual. Replace sensor if still failure.
TC Cal Fail	Failure of temperature calibration.	Clean sensor, check cal solution temperature and repeat sensor temp calibration. TC calibration function only allows adjustments of +/- 6 °C. If still failure, perform sensor tests as described in sensor manual. Replace sensor if still failure. Note that TC offset may also be adjusted using the Cal TC Factor function (see Section 5.23) which involves no calibration reference solutions.
EEprom Fail	Internal nonvolatile memory failure	System failure, consult factory.
Chcksum Fail	Internal software storage error.	System failure, consult factory.
Display Fail	Internal display driver fail.	System failure, consult factory.
Range Cal Fail	Failure of factory temperature calibration.	Consult factory.

10.4 Cleaning the Sensor

Keep the sensor as clean as possible for optimum measurement accuracy. Frequency of cleaning depends upon the process solution. Note that residue from calibration or cleaning solutions, and even skin contact, can leave trace elements on the sensor that may affect the conductivity measurement. This is especially true for extremely low conductivity applications. Whenever cleaning or calibration is performed, make sure that all potential contaminants are removed from the sensor before replacing it into the process.



NOTE: Mechanical cleaning of the electrode surfaces may harm measurement quality. Do NOT use wire brushes, sandpaper or the like to clean any conductivity electrode.

Wipe the inner electrode rod and the outer electrode tube (both inner and outer surfaces) with a clean soft cloth or soft bristle brush. Then wash with warm soapy water. Rinse with tap water to completely remove soap, then final rinse with distilled or de-ionized water.

If necessary, soak the sensor for several minutes in the mild soap solution. Soak for a few minutes, then rinse the sensor thoroughly with clean tap water, and then rinse again with distilled or de-ionized water.



NOTE: De-ionized water will not remove soap.

After cleaning the sensor, check measurement and re-calibrate the sensor if necessary.

10.5 Sensor Testing

The first step in resolving any measurement problem is to determine whether the trouble lies in the sensor or the transmitter. Since measurement problems can often be traced to foulants coating the electrodes, cleaning the sensor using the method outlined in Section 10.4 should always be the first step in any troubleshooting.

If the sensor cannot be calibrated after cleaning, perform the following test. A multimeter will be needed.

1. Disconnect the sensor from the transmitter or junction box.
2. Using a multimeter, measure the resistance across the red and black wires of the sensor cable. It should appear open (no shorts). If a short exists, then cut off 6" from the end of the sensor cable. Strip the sensor wires and perform the test again. If a short still exists, contact factory.
3. Using a multimeter, verify continuity from the red wire to the outer (tube) electrode). Then verify continuity from the black wire to the inner (rod) electrode. If continuity does not exist, contact factory.
4. Verify that the sensor's temperature element (Pt1000 RTD) is functioning properly by measuring the resistance between the sensor's blue and white wires. The nominal resistance value at 25 °C is 1097 ohms. Use the following table as a guide to the approximate resistance value:

°C	RTD Ω
20	1078
25	1097
30	1117
35	1136

Figure 24 - Pt1000 Resistance Table

Spare Parts

<u>Part No.</u>	<u>Description</u>
07-0056	0.05 Cell, Titanium, ½"NPT Comp. fitting (1000 RTD), 15' cable
07-0074	0.05 Cell, Titanium, ½"NPT Comp. fitting (1000 RTD), 30' cable
07-0243	0.50 Cell, Titanium, ½"NPT Comp. fitting (1000 RTD), 15' cable
07-0246	0.05 Cell, Titanium, with Connector (1000 RTD)
07-0247	0.50 Cell, Titanium, with Connector (1000 RTD)
07-0244	0.05 Cell, 316SS, Submersible (1000 RTD)
07-0245	0.50 Cell, 316SS, Submersible (1000 RTD)
07-0231	0.05 Cell, 316SS, 1½" Sanitary fitting (1000 RTD)
07-0242	0.50 Cell, 316SS, 1½" Sanitary fitting (1000 RTD)
03-0394	Q46C2C Front Lid Assembly
07-0326	Q46C2C Monitor, 100-240 VAC
07-0327	Q46C2C Monitor, 12-24 VDC
07-0328	Q46C2C Monitor, 100-240 VAC with Profibus
07-0329	Q46C2C Monitor, 12-24 VDC with Profibus
03-0407	Q46 P/S Assy, 100-240VAC
03-0408	Q46 P/S Assy, 100-240VAC with 3 rd 4-20mA output
03-0409	Q46 P/S Assy, 100-240VAC with 3 relay exp. board
03-0410	Q46 P/S Assy, 12-24 VDC
03-0411	Q46 P/S Assy, 12-24 VDC with 3 rd 4-20mA output
03-0412	Q46 P/S Assy, 12-24 VDC with 3 relay exp. Board
38-0072	Terminal block plug, 3 position (relays)
38-0073	Terminal block plug, 4 position (outputs)
38-0074	Terminal block plug, 3 position (ground)
38-0081	Terminal block plug, 3 position (power)
38-0084	Terminal block plug, 3 position (power) – VDC version*
*NOTE: prior to Dec 2018, VDC (power) Terminal block used the (38-0081)	
23-0029	Fuse, 630mA, 250V, TR-5 (for AC and DC Analyzers)
07-0100	Junction Box
31-0057	Sensor interconnect cable
00-1393	½" NPT SS Compression Fitting w/Teflon Ferrule
44-0242	Replacement Ferrule, Teflon

Lock/Unlock Code: 1468

PRODUCT WARRANTY

Analytical Technology, Inc. (Manufacturer) warrants to the Customer that if any part(s) of the Manufacturer's equipment proves to be defective in materials or workmanship within the earlier of 18 months of the date of shipment or 12 months of the date of start-up, such defective parts will be repaired or replaced free of charge. Inspection and repairs to products thought to be defective within the warranty period will be completed at the Manufacturer's facilities in Collegeville, PA. Products on which warranty repairs are required shall be shipped freight prepaid to the Manufacturer. The product(s) will be returned freight prepaid and allowed if it is determined by the manufacturer that the part(s) failed due to defective materials or workmanship.

This warranty does not cover consumable items, batteries, or wear items subject to periodic replacement including lamps and fuses.

Gas sensors carry a 12 months from date of shipment warranty and are subject to inspection for evidence of misuse, abuse, alteration, improper storage, or extended exposure to excessive gas concentrations. Should inspection indicate that sensors have failed due to any of the above, the warranty shall not apply.

The Manufacturer assumes no liability for consequential damages of any kind, and the buyer by acceptance of this equipment will assume all liability for the consequences of its use or misuse by the Customer, his employees, or others. A defect within the meaning of this warranty is any part of any piece of a Manufacturer's product which shall, when such part is capable of being renewed, repaired, or replaced, operate to condemn such piece of equipment.

This warranty is in lieu of all other warranties (including without limiting the generality of the foregoing warranties of merchantability and fitness for a particular purpose), guarantees, obligations or liabilities expressed or implied by the Manufacturer or its representatives and by statute or rule of law.

This warranty is void if the Manufacturer's product(s) has been subject to misuse or abuse, or has not been operated or stored in accordance with instructions, or if the serial number has been removed.

Analytical Technology, Inc. makes no other warranty expressed or implied except as stated above.

WATER QUALITY MONITORS

Dissolved Oxygen
Free Chlorine
Combined Chlorine
Total Chlorine
Residual Chlorine Dioxide
Potassium Permanganate
Dissolved Ozone
pH/ORP
Conductivity
Hydrogen Peroxide
Peracetic Acid
Dissolved Sulfide
Residual Sulfite
Fluoride
Dissolved Ammonia
Turbidity
Suspended Solids
Sludge Blanket Level
MetriNet Distribution Monitor

GAS DETECTION PRODUCTS

NH ₃	Ammonia
CO	Carbon Monoxide
H ₂	Hydrogen
NO	Nitric Oxide
O ₂	Oxygen
CO	Cl ₂ Phosgene
Br ₂	Bromine
Cl ₂	Chlorine
ClO ₂	Chlorine Dioxide
F ₂	Fluorine
I ₂	Iodine
H _x	Acid Gases
C ₂ H ₄ O	Ethylene Oxide
C ₂ H ₆ O	Alcohol
O ₃	Ozone
CH ₄	Methane (Combustible Gas)
H ₂ O ₂	Hydrogen Peroxide
HCl	Hydrogen Chloride
HCN	Hydrogen Cyanide
HF	Hydrogen Fluoride
H ₂ S	Hydrogen Sulfide
NO ₂	Nitrogen Dioxide
NO _x	Oxides of Nitrogen
SO ₂	Sulfur Dioxide
H ₂ Se	Hydrogen Selenide
B ₂ H ₆	Diborane
GeH ₄	Germane
AsH ₃	Arsine
PH ₃	Phosphine
SiH ₄	Silane
HCHO	Formaldehyde
C ₂ H ₄ O ₃	Peracetic Acid
DMA	Dimethylamine